

SREB

SREB Readiness Courses
Transitioning to college and careers

College Readiness Mathematics

Ready for college-level math
Version 3

Southern
Regional
Education
Board

592 Tenth Street, NW
Atlanta, GA 30318
(404) 875-9211

www.sreb.org

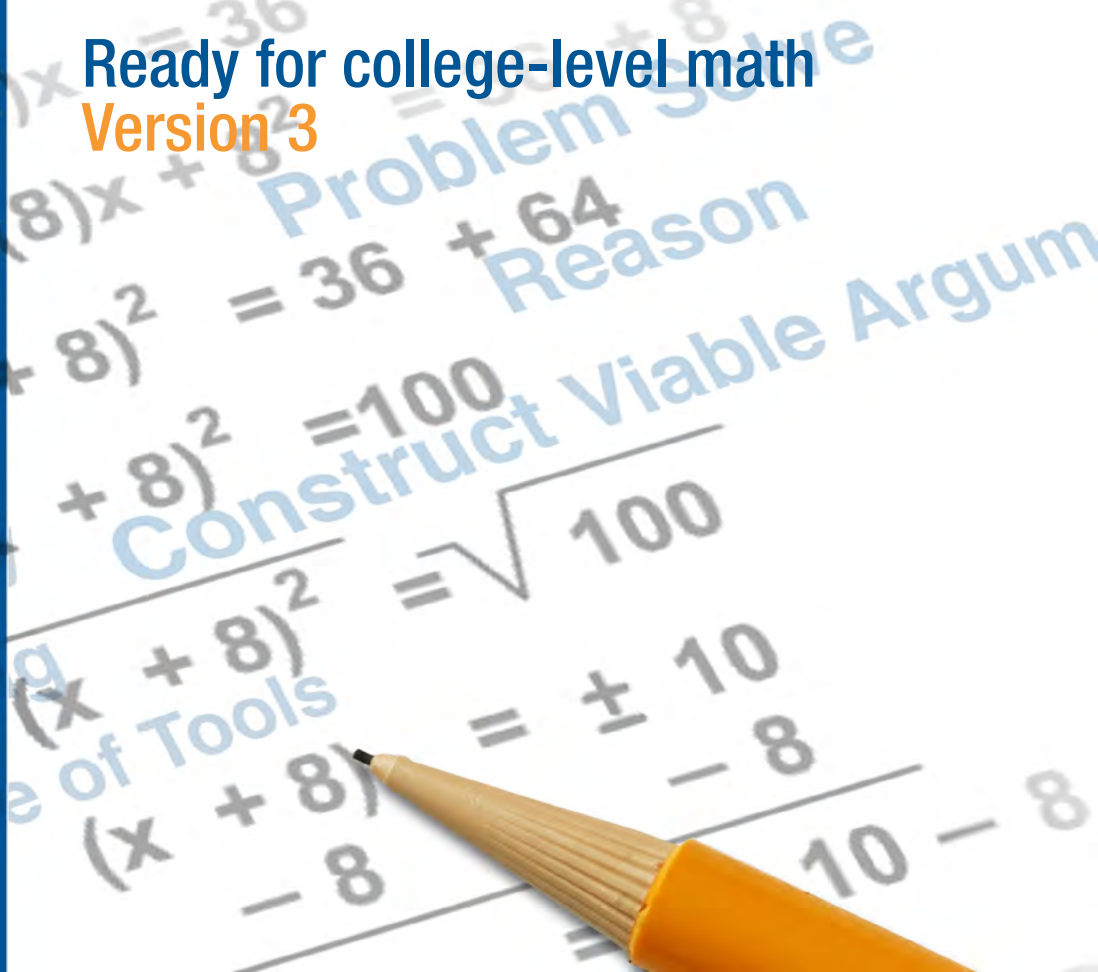

Contents

*To view each unit or navigate to lesson plans, click on the Bookmarks toolbar which is located on the left side of the pdf.

Introduction

Unit 1: Algebraic Expressions

Unit 1: Student Manual

Unit 2: Equations

Unit 2: Student Manual

Unit 3: Measurement and Proportional Reasoning

Unit 3: Student Manual

Unit 4: Linear Functions

Unit 4: Student Manual

Unit 5: Linear Systems of Equations

Unit 5: Student Manual

Unit 6: Quadratic Functions

Unit 6: Student Manual

Unit 7: Exponential Functions

Unit 7: Student Manual

Unit 8: Summarizing and Interpreting Statistical Data

Unit 8: Student Manual

References

Introduction

SREB Readiness Courses

SREB has worked for over a decade with states to introduce policies and programs that address the issue of too many students graduating from high school not prepared for success in the college classroom or workplace. For states that wish to close the readiness gap, SREB has developed two sets of readiness courses in literacy and mathematics. The Ready for College courses are designed to give underprepared students a solid foundation for success in college and postsecondary training. The Ready for High School courses offer an earlier intervention, reaching underprepared students as they enter high school, which for many students is the most critical time in their education in determining future success.

Ready for College Courses: Prepared for College and Careers

By implementing senior-year courses in literacy and mathematics for underprepared students, schools can give students the foundation they need for success in postsecondary studies. SREB offers two courses, *Literacy Ready* and *Math Ready*, designed to prepare students for college before they graduate from high school. These courses are being implemented in thousands of high schools across the nation, and are available as a free download from www.sreb.org/readiness-courses-literacy-math.

Math Ready

This course emphasizes an understanding of math concepts, as opposed to memorizing facts. Math Ready students learn the context behind procedures and come to understand why to use a certain formula or method to solve a problem. By engaging students in real-world applications, this course develops critical thinking skills that students will use in college and careers.

The course consists of eight units: algebraic expressions, equations, measurement and proportional reasoning, linear functions, systems of linear equations, quadratic functions, exponential functions, and statistics.

Unit 1: Algebraic Expressions

The algebraic expressions unit was designed to solidify student understanding of expressions while providing the students with an opportunity to have success early in the course. The recurring theme integrated in this unit focuses on engaging students using and expanding the concepts found within purposefully chosen activities. Through guided lessons, students will manipulate, create and analyze algebraic expressions and look at the idea of whether different sets of numbers are closed under certain operations. The writing team selected content familiar to the students in this unit to build student confidence and to acclimate students to the course's intended approach to instruction.

Unit 2: Equations

The equations unit calls for students to construct and evaluate problems that involve one or two steps while seeking understanding of how and why equations and inequalities are used in their daily lives. Students are also asked to use the structure of word problems and equations to rewrite and solve equations in different forms revealing different relationships.

Unit 3: Measurement and Proportional Reasoning

This unit deals with unit conversions, using proportions for scaling, and area and volume. It requires higher-order thinking and number sense in order to get to the true intent of the standards covered. It is useful in helping students make connections with math and science or other subjects.

Unit 4: Linear Functions

This unit takes students back to the foundation of all high school mathematics—an in-depth study of linear functions. Along with allowing students to differentiate between relations that are functions and those that are not, the unit helps students specifically examine characteristics of linear functions. By looking closely at linear functions in multiple forms, students are expected to graph and write equations, as well as interpret their meaning in context of the slope and y-intercept. Students conclude with a project allowing them to collect their own data and write a line of best fit from that data.

Unit 5: Linear Systems of Equations

The systems unit deals with solving systems of linear equations. This involves helping students classify solutions (one, none or infinitely many), as well as set up and solve problems using systems of equations. This unit also asks students to choose the best way to solve a system of equations and be able to explain their solutions.

Unit 6: Quadratic Functions

Unit 6 is an expansive look at quadratic functions: their graphs, tables and algebraic functions. It stresses multiple approaches to graphing, solving and understanding quadratics, as students explore, make conjectures and draw conclusions in group-work settings. In this unit, students explore and learn from multiple applications of quadratics. The unit assumes students have seen quadratics before but may not have a concrete, transferrable understanding of quadratic functions. The unit does not cover algebraic manipulations (multiplying and factoring), as these are in earlier units.

Unit 7: Exponential Functions

This unit develops students' fluency in exponential functions through varying real-life financial applications/inquiries. The unit builds student understanding of these higher-level functions and gives them the opportunity to reflect upon the ramifications of their future financial choices.

Unit 8: Summarizing and Interpreting Statistical Data (optional)

In this unit students further develop skills to read, analyze, and communicate (using words, tables, and graphs) relationships and patterns found in data sets of one or more variables. Learning how to choose the appropriate statistical tools and measurements to assist in the analysis, being able to clearly communicate results either in words, graphs, or tables, and being able to read and interpret graphs, measurements, and formulas are crucial skills to have in a world overflowing with data. Students explore these concepts while modeling real contexts based on data they collect.

Acknowledgements

SREB would like to thank many states, organizations and individuals for assisting with the development and production of the SREB Readiness Courses, including teams of educators from our partner states.

Georgia Standards of Excellence

Number and Operations

Reason quantitatively and use units to solve problems.

- MGSE9-12.N.Q.1: Use units of measure (linear, area, capacity, rates, and time) as a way to understand problems:
 - a. Identify, use, and record appropriate units of measure within context, within data displays, and on graphs;
 - b. Convert units and rates using dimensional analysis (English-to-English and Metric-to-Metric without conversion factor provided and between English and Metric with conversion factor);
 - c. Use units within multi-step problems and formulas; interpret units of input and resulting units of output.
- MGSE9-12.N.Q.2: Define appropriate quantities for the purpose of descriptive modeling. Given a situation, context, or problem, students will determine, identify, and use appropriate quantities for representing the situation.

Expressions and Equations

Understand the connections between proportional relationships, lines, and linear equations.

- MGSE8.EE.5: Graph proportional relationships, interpreting the unit rate as the slope of the graph. Compare two different proportional relationships represented in different ways. *For example, compare a distance-time graph to a distance-time equation to determine which of two moving objects has greater speed.*
- MGSE8.EE.6: Use similar triangles to explain why the slope m is the same between any two distinct points on a non-vertical line in the coordinate plane; derive the equation $y = mx$ for a line through the origin and the equation $y = mx + b$ for a line intercepting the vertical axis at b .

Analyze and solve linear equations and pairs of simultaneous linear equations.

- MGSE8.EE.7: Solve linear equations in one variable.

Algebra

Interpret the structure of expressions.

- MGSE9-12.A.SSE.1: Interpret expressions that represent a quantity in terms of its context.
- MGSE9-12.A.SSE.1a: Interpret parts of an expression, such as terms, factors and coefficients, in context.
- MGSE9-12.A.SSE.1b: Given situations which utilize formulas or expressions with multiple terms and/or factors, interpret the meaning (in context) of individual terms or factors.
- MGSE9-12.A.SSE.2: Use the structure of an expression to rewrite it in different equivalent forms. For example, see $x^4 - y^4$ as $(x^2)^2 - (y^2)^2$, thus recognizing it as a difference of squares that can be factored as $(x^2 - y^2)(x^2 + y^2)$.

Write expressions in equivalent forms to solve problems.

- MGSE9-12.A.SSE.3: Choose and produce an equivalent form of an expression to reveal and explain properties of the quantity represented by the expression.

College Readiness Mathematics: Ready for college-level math

- MGSE9-12.A.SSE.3a: Factor any quadratic expression to reveal the zeros of the function defined by the expression.
- MGSE9-12.A.SSE.3b: Complete the square in a quadratic expression to reveal the maximum or minimum value of the function defined by the expression.

Creating Equations

Create equations that describe numbers or relationships.

- MGSE9-12.A.CED.1: Create equations and inequalities in one variable and use them to solve problems. Include equations arising from linear, quadratic, simple rational, and exponential functions (integer inputs only).
- MGSE9-12.A.CED.2: Create linear, quadratic, and exponential equations in two or more variables to represent relationships between quantities; graph equations on coordinate axes with labels and scales. (The phrase “in two or more variables” refers to formulas like the compound interest formula, in which $A = P(1 + r/n)^{nt}$ has multiple variables.)
- MGSE9-12.A.CED.3: Represent constraints by equations or inequalities, and by systems of equations and/or inequalities, and interpret data points as possible (i.e. a solution) or not possible (i.e. a non-solution) under the established constraints.
- MGSE9-12.A.CED.4: Rearrange formulas to highlight a quantity of interest using the same reasoning as in solving equations. Examples: Rearrange Ohm’s law $V = IR$ to highlight resistance R ; Rearrange area of a circle formula $A = \pi r^2$ to highlight the radius, r .

Reasoning with Equations and Inequalities

Understand solving equations as a process of reasoning and explain the reasoning.

- MGSE9-12.A.REI.1: Using algebraic properties and the properties of real numbers, justify the steps of a simple, one-solution equation. Students should justify their own steps, or if given two or more steps of an equation, explain the progression from one step to the next using properties.
- MGSE9-12.A.REI.2: Solve simple rational and radical equations in one variable, and give examples showing how extraneous solutions may arise.

Solve equations and inequalities in one variable.

- MGSE9-12.A.REI.3: Solve linear equations and inequalities in one variable including equations with coefficients represented by letters. For example, given $ax + 3 = 7$, solve for x .
- MGSE9-12.A.REI.4: Solve quadratic equations in one variable.
- MGSE9-12.A.REI.4a: Use the method of completing the square to transform any quadratic equation in x into an equation of the form $(x - p)^2 = q$ that has the same solutions. Derive the quadratic formula from $ax^2 + bx + c = 0$.
- MGSE9-12.A.REI.4b: Solve quadratic equations by inspection (e.g., for $x^2 = 49$), taking square roots, factoring, completing the square, and the quadratic formula, as appropriate to the initial form of the equation (limit to real number solutions).

Solve systems of equations.

- MGSE9-12.A.REI.5: Show and explain why the elimination method works to solve a system of two-variable equations.

College Readiness Mathematics: Ready for college-level math

- MGSE9-12.A.REI.6: Solve systems of linear equations exactly and approximately (e.g., with graphs), focusing on pairs of linear equations in two variables.
- MGSE9-12.A.REI.7: Solve a simple system consisting of a linear equation and a quadratic equation in two variables algebraically and graphically. For example, find the points of intersection between the line $y = -3x$ and the circle $x^2 + y^2 = 3$.

Represent and solve equations and inequalities graphically.

- MGSE9-12.A.REI.11: Using graphs, tables, or successive approximations, show that the solution to the equation $f(x) = g(x)$ is the x -value where the y -values of $f(x)$ and $g(x)$ are the same.
- MGSE9-12.A.REI.12: Graph the solution set to a linear inequality in two variables.

Functions

Define, evaluate and compare functions.

- MGSE8.F.1: Understand that a function is a rule that assigns to each input exactly one output. The graph of a function is the set of ordered pairs consisting of an input and the corresponding output.
- MGSE8.F.2: Compare properties of two functions each represented in a different way (algebraically, graphically, numerically in tables, or by verbal descriptions). *For example, given a linear function represented by a table of values and a linear function represented by an algebraic expression, determine which function has the greater rate of change.*
- MGSE8.F.3: Interpret the equation $y = mx + b$ as defining a linear function whose graph is a straight line; give examples of functions that are not linear. For example, the function $A = s^2$ giving the area of a square as a function of its side length is not linear because its graph contains the points (1, 1), (2, 4) and (3, 9), which are not on a straight line.

Use functions to model relationships between quantities.

- MGSE8.F.4: Construct a function to model a linear relationship between two quantities. Determine the rate of change and initial value of the function from a description of a relationship or from two (x,y) values, including reading these from a table or from a graph. Interpret the rate of change and initial value of a linear function in terms of the situation it models, and in terms of its graph or a table of values.

Interpret functions that arise in application in terms of the context.

- MGSE9-12.F.IF.4: Using tables, graphs, and verbal descriptions, interpret the key characteristics of a function which models the relationship between two quantities. Sketch a graph showing key features including: intercepts; interval where the function is increasing, decreasing, positive, or negative; relative maximums and minimums; symmetries; end behavior; and periodicity.

Analyze functions using different representations.

- MGSE9-12.F.IF.7: Graph functions expressed algebraically and show key features of the graph both by hand and by using technology
- MGSE9-12.F.IF.7a: Graph linear and quadratic functions and show intercepts, maxima and minima (as determined by the function or by context).

College Readiness Mathematics: Ready for college-level math

- MGSE9-12.F.IF.7e: Graph exponential and logarithmic functions, showing intercepts and end behavior, and trigonometric functions, showing period, midline and amplitude.
- MGSE9-12.F.IF.8: Write a function defined by an expression in different but equivalent forms to reveal and explain different properties of the function.
- MGSE9-12.F.IF.8a: Use the process of factoring and completing the square in a quadratic function to show zeros, extreme values and symmetry of the graph, and interpret these in terms of a context. For example, compare and contrast quadratic functions in standard, vertex and intercept forms.
- MGSE9-12.F.IF.8b: Use the properties of exponents to interpret expressions for exponential functions. For example, identify percent rate of change in functions such as $y = (1.02)^t$, $y = (0.97)^t$, $y = (1.01)^{(12t)}$, $y = (1.2)^{(t/10)}$ and classify them as representing exponential growth and decay.
- MGSE9-12.F.IF.9: Compare properties of two functions each represented in a different way (algebraically, graphically, numerically in tables, or by verbal descriptions). For example, given a graph of one function and an algebraic expression for another, say which has the larger maximum.

Build a function that models a relationship between two quantities.

- MGSE9-12.F.BF.1: Write a function that describes a relationship between two quantities.
- MGSE9-12.F.BF.1a: Determine an explicit expression and recursive process (steps for calculation) from context. For example, if Jimmy starts out with \$15 and earns \$2 a day, the explicit expression “ $2x + 15$ ” can be described recursively (either in writing or verbally) as “to find out how much money Jimmy will have tomorrow, you add \$2 to his total today.” $J_n = J_{n-1} + 2$, $J_0 = 15$
- MGSE9-12.F.BF.2: Write arithmetic and geometric sequences recursively and explicitly, use them to model situations, and translate between the two forms. Connect arithmetic sequences to linear functions and geometric sequences to exponential functions.

Build new functions from existing functions.

- MGSE9-12.F.BF.3: Identify the effect on the graph of replacing $f(x)$ by $f(x) + k$, $k f(x)$, $f(kx)$, and $f(x + k)$ for specific values of k (both positive and negative); find the value of k given the graphs. Experiment with cases and illustrate an explanation of the effects on the graph using technology. Include recognizing even and odd functions from their graphs and algebraic expressions for them.

Construct and compare linear, quadratic and exponential models and solve problems.

- MGSE9-12.F.LE.1: Distinguish between situations that can be modeled with linear functions and with exponential functions.
- MGSE9-12.F.LE.1a: Show that linear functions grow by equal differences over equal intervals and that exponential functions grow by equal factors over equal intervals. (This can be shown by algebraic proof, with a table showing differences or by calculating average rates of change over equal intervals.)
- MGSE9-12.F.LE.1b: Recognize situations in which one quantity changes at a constant rate per unit interval relative to another.

College Readiness Mathematics: Ready for college-level math

- MGSE9-12.F.LE.1c: Recognize situations in which a quantity grows or decays by a constant percent rate per unit interval relative to another.
- MGSE9-12.F.LE.2: Construct linear and exponential functions, including arithmetic and geometric sequences, given a graph, a description of a relationship, or two input-output pairs (include reading these from a table).
- MGSE9-12.F.LE.3: Observe using graphs and tables that a quantity increasing exponentially eventually exceeds a quantity increasing linearly, quadratically, or (more generally) as a polynomial function.

Interpret expressions for functions in terms of the situation they model.

- MGSE9-12.F.LE.5: Interpret the parameters in a linear ($f(x) = mx + b$) and exponential ($f(x) = a \cdot dx$) function in terms of context. (In the functions above, “m” and “b” are the parameters of the linear function, and “a” and “d” are the parameters of the exponential function.) In context, students should describe what these parameters mean in terms of change and starting value.

Geometry

Use coordinates to prove simple geometric theorems algebraically.

- MGSE9-12.G.GPE.4: Use coordinates to prove simple geometric theorems algebraically. For example, prove or disprove that a figure defined by four given points in the coordinate plane is a rectangle; prove or disprove that the point $(1, \sqrt{3})$ lies on the circle centered at the origin and containing the point $(0,2)$. (Focus on quadrilaterals, right triangles, and circles.)
- MGSE9-12.G.GPE.7: Use coordinates to compute perimeters of polygons and areas of triangles and rectangles, e.g., using the distance formula.

Explain volume formulas and use them to solve problems.

- MGSE9-12.G.GMD.1: Give informal arguments for geometric formulas.
 - a. Give informal arguments for the formulas of the circumference of a circle and area of a circle using dissection arguments and informal limit arguments.
 - b. Give informal arguments for the formula of the volume of a cylinder, pyramid and cone using Cavalieri’s principle.
- MGSE9-12.G.GMD.3: Use volume formulas for cylinders, pyramids, cones, and spheres to solve problems.

Apply geometric concepts in modeling situations.

- MGSE9-12.G.MG.2: Apply concepts of density based on area and volume in modeling situations(e.g., persons per square mile, BTUs per cubic foot).
- MGSE9-12.G.MG.3: Apply geometric methods to solve design problems (e.g., designing an object or structure to satisfy physical constraints or minimize cost; working with typographic grid systems based on ratios)

Data Analysis and Statistics

Summarize, represent and interpret data on a single count or measurement variable.

- MGSE9-12.S.ID.1: Represent data with plots on the real number line (dot plots, histograms, and box plots).

College Readiness Mathematics: Ready for college-level math

- MGSE9-12.S.ID.2: Use statistics appropriate to the shape of the data distribution to compare center (median, mean) and spread (interquartile range, mean absolute deviation, standard deviation) of two or more different data sets
- MGSE9-12.S.ID.3: Interpret differences in shape, center, and spread in the context of the data sets, accounting for possible effects of extreme data points (outliers).

Summarize, represent and interpret data on two categorical and quantitative variables.

- MGSE9-12.S.ID.5: Summarize categorical data for two categories in two-way frequency tables. Interpret relative frequencies in the context of the data (including joint, marginal, and conditional relative frequencies). Recognize possible associations and trends in the data.
- MGSE9-12.S.ID.6: Represent data on two quantitative variables on a scatter plot, and describe how the variables are related.
- MGSE9-12.S.ID.6a: Decide which type of function is most appropriate by observing graphed data, charted data, or by analysis of context. Emphasize linear, quadratic and exponential models.
- MGSE9-12.S.ID.6c: Using given or collected bivariate data, fit a linear function for a scatter plot that suggests a linear association.

Interpret linear models.

- MGSE9-12.S.ID.7: Interpret the slope (rate of change) and the intercept (constant term) of a linear model in the context of the data.
- MGSE9-12.S.ID.8: Compute (using technology) and interpret the correlation coefficient “ r ” of a linear fit. (For instance, by looking at a scatterplot, students should be able to tell if the correlation coefficient is positive or negative and give a reasonable estimate of the “ r ” value.) After calculating the line of best fit using technology, students should be able to describe how strong the goodness of fit of the regression is, using “ r ”.
- MGSE9-12.S.ID.9: Distinguish between correlation and causation.

Understand and evaluate random processes underlying statistical experiments.

- MGSE9-12.S.IC.1: Understand statistics as a process for making inferences about population parameters based on a random sample from that population.

Make inferences and justify conclusions from sample surveys, experiments and observational studies.

- MGSE9-12.S.IC.3: Recognize the purposes of and differences among sample surveys, experiments, and observational studies; explain how randomization relates to each.

Standard(s) for Mathematical Practice

- SMP 1: Make sense of problems and persevere in solving them.
- SMP 2: Reason abstractly and quantitatively.
- SMP 3: Construct viable arguments and critique the reasoning of others.
- SMP 4: Model with mathematics.
- SMP 5: Use appropriate tools strategically.
- SMP 6: Attend to precision.
- SMP 7: Look for and make use of structure.
- SMP 8: Look for and express regularity in repeated reasoning.

SREB

SREB Readiness Courses
Transitioning to college and careers

College Readiness Mathematics

Unit 1 . Algebraic Expressions
Version 3

Southern
Regional
Education
Board

592 Tenth Street, NW
Atlanta, GA 30318
(404) 875-9211

www.sreb.org

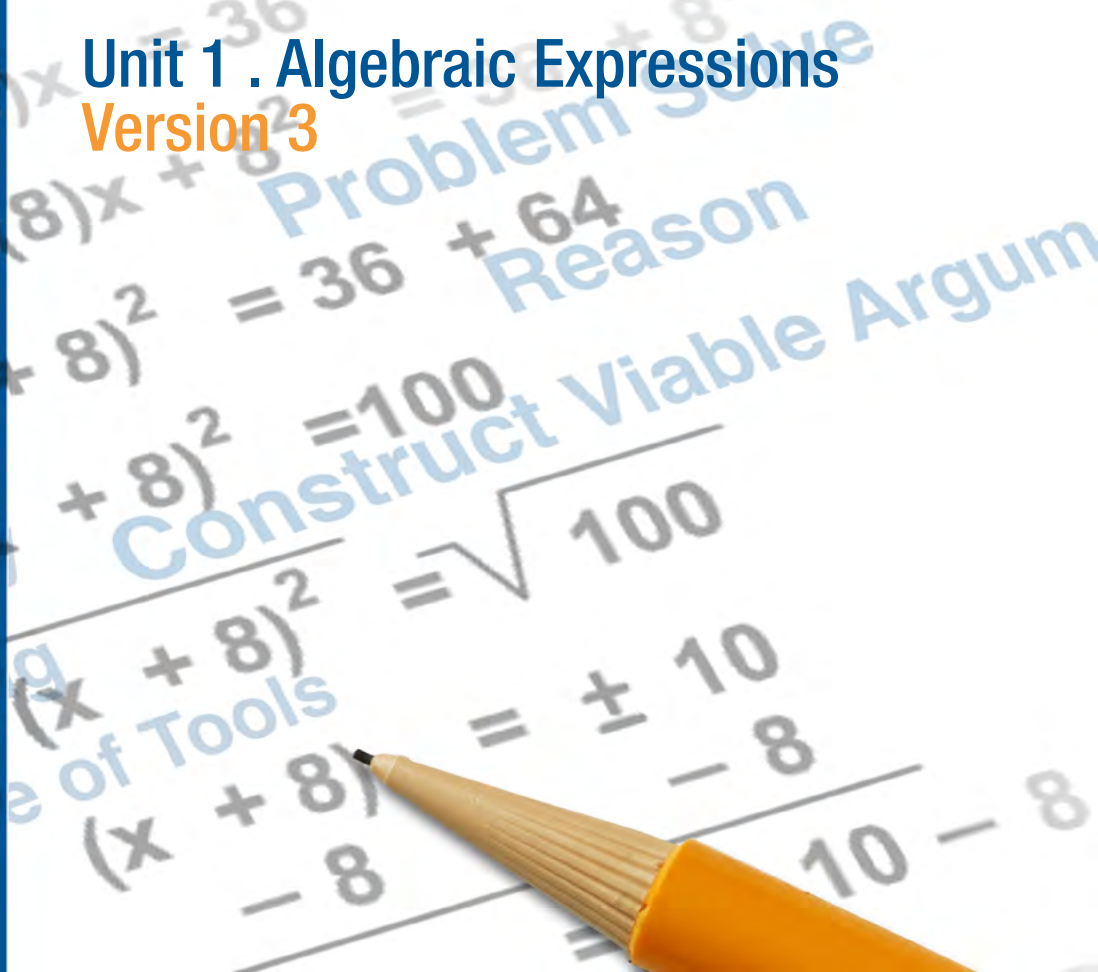

Unit 1 . Algebraic Expressions

Overview

Purpose

This unit was designed to solidify student conception of expressions while providing the students with an opportunity to have success early in the course. The recurring theme integrated in this unit focuses on engaging students using and expanding the concepts found within purposefully chosen activities. Through guided lessons, students will manipulate, create, and analyze algebraic expressions and look at the idea of whether different sets of numbers are closed under certain operations. The writing team selected content familiar to the students in this unit to build student confidence and acclimate students to the course's intended approach to instruction.

Essential Questions:

When is estimation appropriate?

How can you extend the properties of operations on numerical expressions to algebraic expressions?

How can you apply the properties of operations to generate equivalent expressions?

How can you determine when two algebraic expressions are equivalent or not?

How can rewriting an expression in different forms in a problem context can shed light on the problem and how the quantities in it are related?

How can you use the structure of an expression to identify ways to rewrite it?

Georgia Standards of Excellence:

Number Sense, Properties and Operations

Reason quantitatively and use units to solve problems.

- MGSE9-12.N.Q.1: Use units of measure (linear, area, capacity, rates, and time) as a way to understand problems:
 - a. Identify, use, and record appropriate units of measure within context, within data displays, and on graphs;
 - b. Convert units and rates using dimensional analysis (English-to-English and Metric-to-Metric without conversion factor provided and between English and Metric with conversion factor);
 - c. Use units within multi-step problems and formulas; interpret units of input and resulting units of output.

Algebra

Interpret the structure of expressions.

- MGSE9-12.A.SSE.1: Interpret expressions that represent a quantity in terms of its context.
- MGSE9-12.A.SSE.2: Use the structure of an expression to rewrite it in different equivalent forms. For example, see $x^4 - y^4$ as $(x^2)^2 - (y^2)^2$, thus recognizing it as a difference of squares that can be factored as $(x^2 - y^2)(x^2 + y^2)$.

Write expressions in equivalent forms to solve problems.

- MGSE9-12.A.SSE.3: Choose and produce an equivalent form of an expression to reveal and explain properties of the quantity represented by the expression.

Functions

Analyze functions using different representations.

- MGSE9-12.F.IF.8: Write a function defined by an expression in different but equivalent forms to reveal and explain different properties of the function.

Prior Scaffolding Knowledge / Skills:

- Students should be comfortable with applying and extending their understandings of arithmetic to algebraic expressions.
- Students should be able to write, read and evaluate expressions in which letters stand for numbers.
- Students should have a solid command of the operations associated with the number system including operations with fractions and rational numbers.
- Students should have an understanding that expressions can be rewritten into equivalent forms and have strategies from previous understandings of how to rewrite.

Lesson Progression Overview:

Lesson Big Idea	Lesson Details	Georgia Standards of Excellence	Standards for Mathematical Practice
Lesson 1: Numbers and Estimation	Students will be introduced to the course using an estimation activity that will be used to develop conception of numbers and reinforce numeral operation fluency. It is also an entry activity into the course showcasing the explicit incorporation of math practices including problem solving, reasoning and modeling using mathematics.	MGSE9-12.N.Q.1	SMP 2 SMP 3 SMP 4
Lesson 2: Interpreting Expressions	Students will begin this lesson by engaging in a “magic math” activity. This lesson will give students opportunities to explore and determine their understanding of expressions. They will be asked to consider, create and understand verbal representations of numbers and operations to symbolic representations using expressions. They will examine how symbolic manipulation of expressions affects values in real circumstances.	MGSE9-12.A.SSE.1	SMP 2 SMP 6 SMP 7 SMP 8
Lesson 3: Reading and Evaluating	This lesson will give students an opportunity to fortify their understanding of interpreting and modifying expressions by analyzing symbolic manipulation of various expressions.	MGSE9-12.A.SSE.1 MGSE9-12.A.SSE.2	SMP 6 SMP 7
Lesson 4: Comparing Equivalent Expressions	Students will begin this lesson by engaging in a real-life problem that encompasses some basic geometric concepts along with expression manipulation. This lesson will give students an opportunity to fortify their understanding of writing expressions.	MGSE9-12.A.SSE.1 MGSE9-12.A.SSE.2 MGSE9-12.A.SSE.3	SMP 2 SMP 3 SMP 4 SMP 7
Lesson 5: Constructing Equivalent Expressions	Students will begin this lesson by engaging in a task on developing expressions for a particular geometric pattern. This lesson will strengthen the ability of students to compare expressions presented in different forms and determine equivalency.	MGSE9-12-A.SSE.3 MGSE9-12.F.IF.8	SMP 1 SMP 3 SMP 7 SMP 8
Lesson 6: Distributive Property	Students will begin this lesson with an engaging activity that will lead to an understanding of rewriting and interpreting expressions using the distributive property.	MGSE9-12.A.SSE.1 MGSE9-12.A.SSE.2	SMP 3 SMP 4
Lesson 7: Formative Assessment Lesson: Interpreting Algebraic Expressions	This lesson is intended to help teachers assess how well students are able to translate between words, symbols, tables, and area representations of algebraic expressions. It is designed to identify and support students who have difficulty in these concepts. (Shell Center Formative Assessment Lesson: Interpreting Algebraic Expressions)	MGSE9-12.A.SSE.1 MGSE9-12.A.SSE.2	SMP 2 SMP 7

Algebraic Expressions

Lesson 1 of 7

Numbers and Estimation

Description:

Students will be introduced to the course using an estimation activity to develop conception of numbers and reinforce numeral operation fluency. It is also an entry activity into the course showcasing the explicit incorporation of math process readiness indicators including problem solving, reasoning and modeling using mathematics.

Georgia Standards of Excellence Addressed:

- MGSE9-12.N.Q.1: Use units of measure (linear, area, capacity, rates, and time) as a way to understand problems:
 - a. Identify, use, and record appropriate units of measure within context, within data displays, and on graphs;
 - b. Convert units and rates using dimensional analysis (English-to-English and Metric-to-Metric without conversion factor provided and between English and Metric with conversion factor);
 - c. Use units within multi-step problems and formulas; interpret units of input and resulting units of output.

Standard(s) for Mathematical Practice:

- SMP 2: Reason abstractly and quantitatively.
- SMP 3: Construct viable arguments and critique the reasoning of others.
- SMP 4: Model with mathematics.

Sequence of
Instruction

Activities Checklist

Engage



Entry Event: Play initial clip of Bucky the Badger. This content is from Dan Meyer's Three Act Math: <http://mrmeyer.com/threeacts/buckythebadger/>.

Following the initial video clip (Act 1), ask students to guess how many push-ups Bucky had to perform in the course of the game. If a student responds by saying 83, then explain again how the number of pushups is calculated. After asking several students for approximations, split students up into groups of three or so students to further explore this question.

Explore



Ask the groups to construct viable arguments and critique the reasoning of others as they address the following questions:

INCLUDED IN THE STUDENT MANUAL

Task #1: Bucky the Badger

- Restate the Bucky the Badger problem in your own words.
- About how many total push-ups do you think Bucky did during the game?
- Write down a number that you know is too high.
- Write down a number that you know is too low.
- What further information would you need to know in order to determine the exact number of total push-ups Bucky did in the course of the game?
- If you're Bucky, would you rather your team score their field goals at the start of the game or the end?
- What are some numbers of pushups that Bucky will never do in any game?

The key here is that the total depends on the order in which the touchdowns and field goals were scored, not just how many touchdowns and field goals were scored.

Explanation

Play clip that explains how many push-ups in total Bucky did (whether it is Bucky or more than one person is still a mystery!)

Address any questions or issues that may have come up as you observed the groups discuss the questions above.

Teacher's Note – A blog discussing the Bucky the Badger problem and the incorporation of problem solving and communication can be found at <http://blog.mrmeyer.com/?p=13514>. This may be used by the instructor to reflect on his/her own understandings and beliefs surrounding math Process Readiness Indicators.

Practice Together in Small Groups



No calculator should be used for Tasks 1 and 2. It is important to stress that in Task #2, students are asked to find approximate values. If students find themselves wanting or needing to use a calculator, give them a hand in reasoning abstractly and quantitatively through useful approximation strategies that help find a good estimate while being easy to compute.

INCLUDED IN THE STUDENT MANUAL

Task #2: Reasoning about Multiplication and Division and Place Value

Use the fact that $13 \times 17 = 221$ to find the following:

- | | |
|---------------------|--------------------|
| a. 13×1.7 | e. $2210 \div 13$ |
| b. 130×17 | f. $22100 \div 17$ |
| c. 13×1700 | g. $221 \div 1.3$ |
| d. 1.3×1.7 | |

(<http://illustrativemathematics.org/illustrations/272>)

Commentary *for the Teacher:*

This task is NOT an example of a task asking students to compute using the standard algorithms for multiplication and division because most people know what those kinds of problems look like. Instead, this task shows what kinds of reasoning and estimation strategies students need to develop in order to support their algorithmic computations.

Possible Solutions:

All these solutions use the associative and commutative properties of multiplication (explicitly or implicitly).

- a. $13 \times 1.7 = 13 \times (17 \times 0.1) = (13 \times 17) \times 0.1$, so the product is one-tenth the product of 13 and 17. In other words:

$$13 \times 1.7 = 22.1$$

- b. Since one of the factors is ten times one of the factors in 13×17 , the product will be ten times as large as well:

$$130 \times 17 = 2210$$

- c. $13 \times 1700 = 13 \times (17 \times 100) = (13 \times 17) \times 100$, so

$$13 \times 1700 = 22100$$

- d. Since each of the factors is one tenth the corresponding factor in 13×17 , the product will be one one-hundredth as large:

$$1.3 \times 1.7 = 2.21$$

- e. $2210 \div 13 = ?$ is equivalent to $13 \times ? = 2210$. Since the product is ten times as big and one of the factors is the same, the other factor must be ten times as big. So:

$$2210 \div 13 = 170$$

- f. As in the previous problem, the product is 100 times as big, and since one factor is the same, the other factor must be 100 times as big:

$$22100 \div 17 = 1300$$

- g. $221 \div 1.3 = ?$ is equivalent to $1.3 \times ? = 221$. Since the product is the same size and one of the factors is one-tenth the size, the other factor must be ten times as big. So:

$$221 \div 1.3 = 170$$

INCLUDED IN THE STUDENT MANUAL

Task #3: Felicia's Drive

As Felicia gets on the freeway to drive to her cousin's house, she notices that she is a little low on gas. There is a gas station at the exit she normally takes but she wonders if she will have to get gas before then. She normally sets her cruise control at the speed limit of 70mph and the freeway portion of the drive takes about an hour and 15 minutes. Her car gets about 30 miles per gallon on the freeway, and gas costs \$3.50 per gallon.

(<http://illustrativemathematics.org/illustrations/80>)

- Describe an estimate that Felicia might do in her head while driving to decide how many gallons of gas she needs to make it to the gas station at the other end.
- Assuming she makes it, how much does Felicia spend per mile on the freeway?

Commentary *for the Teacher:*

This task provides students the opportunity to make use of units to find the gas needed. It also requires them to make some sensible approximations (e.g., 2.92 gallons is not a good answer to part (a)) and to recognize that Felicia's situation requires her to round up. Various answers to (a) are possible, depending on how much students think is a safe amount for Felicia to have left in the tank when she arrives at the gas station. The key point is for them to explain their choices. This task provides an opportunity for students to practice reasoning abstractly and quantitatively, and constructing viable arguments and critiquing the reasoning of others.

Possible Solution:

- a. To estimate the amount of gas she needs, Felicia calculates the distance traveled at 70 mph for 1.25 hours. She might calculate:

$$70 \times 1.25 = 70 + 0.25 \times 70 = 70 + 17.5 = 87.5 \text{ miles}$$

Since 1 gallon of gas will take her 30 miles, 3 gallons of gas will take her 90 miles, a little more than she needs. So she might figure that 3 gallons is enough.

Or, since she is driving, she might not feel like distracting herself by calculating 0.25×70 mentally, so she might replace 70 with 80, figuring that that will give her a larger distance than she needs. She calculates:

$$80 \times 1.25 = 80 + 4 \times 80 = 100$$

So at 30 miles per gallon, 3.13 gallons will get her further than she needs to go and should be enough to get her to the gas station.

- b. Since Felicia pays \$3.50 for one gallon of gas, and one gallon of gas takes her 30 miles, it costs her \$3.50 to travel 30 miles. Therefore, $\$3.50/30 \text{ miles} = \0.121 , meaning it costs Felicia 12 cents to travel each mile on the freeway.

Evaluate Understanding

Ask some students to share their strategies for solving some of the questions above. Be sure to emphasize good (and bad) approximation strategies, paying attention to units when appropriate, and reviewing the properties of operations when working with numerical expressions. Do NOT mention anything about PEMDAS. Students should use any (correct) order of operations, and the order of those operations should be a result of useful strategies. For example:

$$1.3 \times 1.7 = (13) \times \left(\frac{1}{10}\right) \times (17) \times \left(\frac{1}{10}\right) = \frac{1}{100} \times (13 \times 17) = \left(\frac{1}{100}\right) \times (221) = 2.21$$

Here the strategy is using commutative and associative properties of multiplication rather than inventing a gimmicky trick with decimals that works in this one particular case. Reviewing and deepening the depth of understanding of these properties is crucial before moving on to working with algebraic expressions.

Closing Activity

Still working in groups, ask the students to model with mathematics the following situation:

Let x denote the number of touchdowns Wisconsin scored in a game. Assuming the Wisconsin football team only scores touchdowns, write an algebraic expression

to represent the total number of pushups Bucky must do in a game in which x touchdowns are scored.

Independent Practice:

For this lesson the Independent Practice is the Closing Activity. Students may have started sharing ideas on how to find a general expression. Have them complete the solution outside of class.

Resources/Instructional Materials Needed:

Computer/Projector

Video Clip: **Three Act Math:** Bucky the Badger — (<http://mrmeyer.com/threeacts/buckythebadger/>)

Notes:

Algebraic Expressions

Lesson 2 of 7

Interpreting Expressions

Description:

Students will begin this lesson by engaging in a “magic math” activity. This lesson will give students opportunities to explore and determine their understanding of expressions. They will be asked to consider, create and understand verbal representations of numbers and operations to symbolic representations using expressions. They will examine how symbolic manipulation of expressions affects values in real circumstances.

Georgia Standards of Excellence Addressed:

- MGSE9-12.A.SSE.1: Interpret expressions that represent a quantity in terms of its context.

Standard(s) for Mathematical Practice Emphasized:

- SMP 2: Reason abstractly and quantitatively.
- SMP 6: Attend to precision.
- SMP 7: Look for and make use of structure.
- SMP 8: Look for and express regularity in repeated reasoning.

Sequence of Instruction	Activities Checklist
-------------------------	----------------------

Engage

Magic Math: Number Guess Introduction

- Have each student choose a number between one and 20 and write it down at the top of the Magic Math template provided in the student manual.
- Students should complete the following steps on their paper under their original number and write the instructions given in the second column:
 - Double your original number.
 - Add 6.
 - Divide by 2.
 - Subtract the original number from the new number.
 - Fold the paper once so your work/answer cannot be seen.

INCLUDED IN THE STUDENT MANUAL

Numbers and Operations Magic Math



Original Number	Instructions

- Tell the students that you are going to come around and write your “guess” for their answer on the outside of the paper.
- Go around the room and write a 3 on the outside of their paper and turn your writing face down on the desk.
- Once you are finished writing your “guesses” on all of the papers ask them to look at your guess and if it matches their answer then have them raise their hand. (Hopefully all students will have their hand up at this point; however, if some do not just make note of it and address their calculation mistakes during the practice session).
- Make a “big deal” about how they must have all chosen the same original number.
- Ask two different students what numbers they chose. When you get two different original numbers, look puzzled, as if to say “How could that be?”
- Ask the class as a whole, “How is it that <John> started with <4> and <Jane> started with <11>? They both performed the same operations on the two different numbers, but ended up with the same answer.
- Tell the students that you are going to give some time to discuss it.

Explore



Magic Math: Number Guess Exploration

- Have students pair up (one group of three if an odd number of students are present) with someone that chose a different original number.
- Have students discuss and write down on a sheet of paper their pair’s understanding of why this process always results in a “3.” Ask them to create a visual model of their thoughts. Have students look for and make use of structure as they create an expression representing all of the steps in the magic math number trick.
- Announce that if anyone did not get “3” as their answer (from a miscalculation), he/she should discuss the steps taken to arrive at the different solution with his/her partner. (Listen to the conversation surrounding the students’ process and be prepared to ask guiding questions as necessary to help students find their errors in the event they are unable to locate the miscalculation.)
- Give time for student pairs to both quantitatively and abstractly reason through the problem and provide sound justification for their decisions.
- Walk around the room observing the explanations/models. Pay attention to the different correct approaches. Make note of any incorrect assumptions/processes.

Explanation



Magic Math: Number Guess Explanation

- Ask one to three groups to communicate methods and solutions precisely to others through a report of their processes. Try to select groups that have varying methods.
 - There is no need for the same exact process to be explained multiple times so choose pairs having some variations to share.
 - If you had one group that has an incorrect process you might sandwich them



between two correct groups. This way the students can solidify their thoughts with the first group. The second group will probably see their error and address it when presenting (but this provides a great opportunity for a group discussion about the reason for their miscalculation). Then the third group will provide reinforcement of the procedure.

- Leave students in their current groups and facilitate a whole group discussion about the process to include verbal, algebraic, and modeling representations.

Magic Math: Number Guess (Explanations)

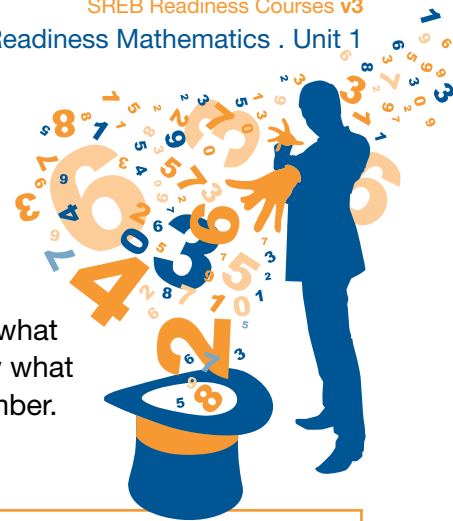
When I asked you to choose a number between one and 20, I had no real idea what you would choose. And in math, if we know a number exists but we don't know what particular number it is, then we use a variable or a symbol to represent that number. So let's go through this problem with ★ and x representing the chosen number.

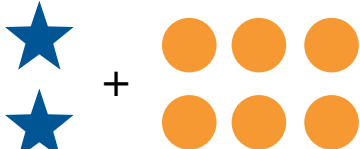
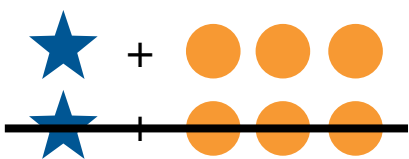

Modeling Explanation	Verbal Process	Algebraic Explanation
★	Chosen Number	x
★ ★	Double it	$x \cdot 2 = 2x$
	Add 6 to it	$2x + 6$
	Divide by 2	$\frac{2x + 6}{2} = x + 3$
	Subtract your original number	$x + 3 - x = 3$
	Leaves 3	3

Practice Together in Small Groups



Magic Math: Birthday Trick

- Have students work in pairs to complete the Math Magic: Birthday Trick from the Student Manual, taking turns with each student's own information.

INCLUDED IN THE STUDENT MANUAL

Do you believe that I can figure out your birthday by using simple math?

Get a calculator and ask your classmate to try the following. Your classmate must press equal (or enter) between every step.

- a) Enter the month of his/her birth into the calculator. (Ex: enter 5 for May)
 - b) Multiply that number by 7.
 - c) Subtract 1 from that result.
 - d) Multiply that result by 13.
 - e) Add the day of birth. (Ex: For June 14th add 14)
 - f) Add 3.
 - g) Multiply by 11.
 - h) Subtract the month of birth.
 - i) Subtract the day of birth.
 - j) Divide by 10.
 - k) Add 11.
 - l) Divide by 100.
- Have the students look for and make use of repeated reasoning to model the process algebraically.
 - Make sure that each of the members of the group can communicate the process that his/her pair used precisely.
 - Have one student from each pair rotate to a different group.
 - Have each student in the newly formed pairs explain to one another his/her model and the reasoning for each step.

Evaluate Understanding

Magic Math: Birthday Trick

- Monitor the different explanations in the groups and ask guiding questions aimed at correcting any misconceptions that may exist.

Closing Activity

Introduce Independent Practice

- In a whole-group discussion, introduce students to the independent practice where they are asked to create their own "magic trick." The trick should include at least five steps and should be represented through both verbal and algebraic representations. This is to be completed without the use of technology.
- Allow time for students to ask clarifying questions and summarize the independent practice task.

Algebraic Expressions

Lesson 3 of 7

Reading and Evaluating

Description:

This lesson will give students an opportunity to fortify their understanding of interpreting and modifying expressions by analyzing symbolic manipulation of various expressions.

Georgia Standards of Excellence Addressed:

- MGSE9-12.A.SSE.1: Interpret expressions that represent a quantity in terms of its context.
- MGSE9-12-A.SSE.2: Use the structure of an expression to rewrite it in different equivalent forms. For example, see $x^4 - y^4$ as $(x^2)^2 - (y^2)^2$, thus recognizing it as a difference of squares that can be factored as $(x^2 - y^2)(x^2 + y^2)$.

Standard(s) for Mathematical Practice Emphasized:

- SMP 6: Attend to precision.
- SMP 7: Look for and make use of structure.

Sequence of
Instruction

Activities Checklist

Engage



Your Birthday!

Here's a fun trick to show a friend, a group, or an entire class of people. Tell the person (or class) to think of their birthday and you will guess it.

Step 1) Have them take the month number from their birthday: January = 1, Feb = 2, etc.

Step 2) Multiply that by 5.

Step 3) Then add 6.

Step 4) Then multiply that total by 4.

Step 5) Then add 9.

Step 6) Then multiply this total by 5 once again.

Step 7) Finally, have them add to that total the day in which they were born. If they were born on the 18th, they add 18, e.g.

Have them give you the total. In your head, subtract 165 from their total, and you will have the month and day they were born.

Ask students to construct a viable argument explaining why this birthday trick 'works.' Ask them to create an algebraic expression modeling the situations.

How It Works: Let M be the month number and D will be the day number. After the seven steps, the expression for their calculation is:

$$5(4(5M + 6) + 9) + D = 100M + D + 165$$

Thus, if you subtract 165, what remains will be the month in hundreds plus the day.

Explore



Put six different sheets of paper scattered around the room with $+$, $-$, $*$, \div , $=$, $()$
Note: The left and right parentheses can be placed on the same sheet of paper.

Have the students quickly rotate throughout the room, writing key words that may be associated with the symbols provided on the different papers. This can be a timed event of four or five minutes. After the time is up, have different students present the symbols and discuss the words.

Ask students to provide scenarios and create verbal expressions where the various words might be used to denote a specific operation or structure. Have them generate the associated algebraic expression. Discuss any potential conflicts or misconceptions that students may have.

The lists can be edited following the discussion. Have the students record the lists as a future resource.

Group the students into pairs. Write the bolded statements on the board. Ask the groups to find an algebraic expression that represents each statement.

1. **Three times a number minus seven** --- $3x - 7$
2. **A number minus seven, then multiplied by three** --- $3(x - 7)$
3. **A shirt originally cost c dollars and is on sale for 60% of the original cost** --- $\$0.6c$
4. **The total number of hours worked during d days for persons working seven hours each day** --- $7d$
5. **Total amount of pay for working h hours at a wage of \$7.25 per hour** --- $\$7.25h$

Explanation

- After sharing the first two responses, ask students if the written statement and expression are equivalent. Have the students discuss how they determined their answer.
- Ideally some groups evaluated the expressions by substituting the same number into each expression. Others may perform symbolic manipulation to demonstrate that the expressions are not equivalent.
- If students cannot write the generalized algebraic expressions, the teacher may give specific examples to move student understanding to the general expressions. For example, in number four, the teacher may want to use three days and then four days to move to the more general expression.

Practice Together / in Small Groups / Individually



Print and cut out the following **I Have / Who Has** cards. The next two pages (of 16 cards) comprise one complete linked activity.

Algebraic Expressions

I Have / Who Has

I have
 $-4x$

Who has
half of the difference of four times
a number and eight

I have
 $2x-4$

Who has
a third of the difference of eighteen
and six times a number

I have
 $6-2x$

Who has
three multiplied by the result of three
subtracted from ten times a number

I have
 $30x-9$

Who has
the difference of a number
and seven

I have
 $x-7$

Who has
six subtracted from the opposite of the
sum of three times a number and five

I have
 $-3x-11$

Who has
the difference of seven times
a number and one

I have
 $7x-1$

Who has
the difference of eight times a number
and four times the same number

I have
 $4x$

Who has
eight more than three times the
sum of a number and one

Algebraic Expressions

I Have / Who Has

I have
 $3x+11$

Who has
two times a number plus four

I have
 $2x+4$

Who has
add ten to three times a number
subtracted from one

I have
 $-3x+11$

Who has
the difference of three times a number
and eleven

I have
 $3x-11$

Who has
half the sum of double a number and
fourteen

I have
 $x+7$

Who has
subtract ten from a number and
multiply the result by three

I have
 $3x-30$

Who has
the difference of twice a number
and six

I have
 $2x-6$

Who has
seven times a number subtracted from
the same number

I have
 $-6x$

Who has
the difference of four times a number
and eight times the same number

Whole Class Game:

1. Distribute one card to each student. Then distribute the extras to strong students in the beginning and to random students as the class becomes more familiar with the deck.
2. As you distribute the cards, encourage students to begin thinking about what the question for their card might be so that they are prepared to answer. When all cards are distributed, select the student with the starter card to begin. Play continues until the game loops back to the original card. That student answers and then says “the end” to signal the end of the game.

Evaluate Understanding

INCLUDED IN THE STUDENT MANUAL

Task #4: Miles to Kilometers

The students in Mr. Sanchez’s class are converting distances measured in miles to kilometers. To estimate the number of kilometers, Abby takes the number of miles, doubles it and then subtracts 20% of the result. Renato first divides the number of miles by 5 and then multiplies the result by 8.

- a. Write an algebraic expression for each method.
- b. Use your answer to part (a) to decide if the two methods give the same answer.

(<http://illustrativemathematics.org/illustrations/433>)

Commentary for the Teacher:

In this task students are asked to write two expressions from verbal descriptions and determine if they are equivalent. The expressions involve both percent and fractions. This task is most appropriate for a classroom discussion since the statement of the problem has some ambiguity.

Adapted from Algebra: Form and Function, McCallum et al., Wiley 2010

Possible Solution:

Writing and comparing expressions —

1. Abby’s method starts by doubling m , giving $2m$. She then takes 20% of the result, which we can write $0.2(2m)$. Finally she subtracts this from $2m$, giving:

$$2m - (0.2)2m$$

Renato’s method starts by dividing m by 5, giving $m \div 5 = \frac{m}{5}$, and then multiplies the result by 8, giving:

$$8\left(\frac{m}{5}\right)$$

2. Abby’s expression can be simplified as follows:

$$2m - (0.2)2m = 2m - 0.4m = (2 - 0.4)m = 1.6m$$

(The step where we rewrite $2m - 0.4m$ as $(2 - 0.4)m$ uses the distributive property.)

Renato’s method gives:

$$8\left(\frac{m}{5}\right) = 8 \times \frac{m}{5} = \frac{8m}{5} = 1.6m$$

So the two methods give the same answer and the expressions are equivalent.

Closing Activity

Assign Independent Practice and ask students how mathematical structure will be used in the assignment.

Independent Practice:

INCLUDED IN THE STUDENT MANUAL

School Lunches & Movie Tickets

Find the cost of school lunches (adult and student) for three different area schools. Then create a table of values. Also find the number of students and teachers at each school.

Write an expression based on the table for each of the following:

Schools	Student	Adult
A		
B		
C		

- A. Cost of feeding 30 students and 5 adults.
- B. Cost of feeding 43 adults and 75 students.
- C. Cost of feeding each of the school's students and teachers.

Have students find movie tickets prices at five different cities around the country. Include adult, children, matinee and regular shows.

City	Adult matinee	Adult regular	Child matinee	Child regular
A				
B				
C				
D				
E				

- A. You have \$100. In which can you take the most adults and children to the matinee, if for every two children there is an adult?
- B. What is the cost of four children and three adults for a matinee in each of the five cities?
- C. Which city has the best deal for a family of five to attend the movies? Decide whether it is a matinee or regular show?

Algebraic Expressions

Lesson 4 of 7

Comparing Equivalent Expressions

Description:

Students will begin this lesson by engaging in a real-life problem that encompasses some basic geometric concepts along with expression manipulation. This lesson will give students an opportunity to fortify their understanding of writing expressions.

Georgia Standards of Excellence Addressed:

- MGSE9-12.A.SSE.1: Interpret expressions that represent a quantity in terms of its context.
- MGSE9-12-A.SSE.2: Use the structure of an expression to rewrite it in different equivalent forms. For example, see $x^4 - y^4$ as $(x^2)^2 - (y^2)^2$, thus recognizing it as a difference of squares that can be factored as $(x^2 - y^2)(x^2 + y^2)$.
- MGSE9-12.A.SSE.3: Choose and produce an equivalent form of an expression to reveal and explain properties of the quantity represented by the expression.

Standard(s) for Mathematical Practice Emphasized:

- SMP 2: Reason abstractly and quantitatively.
- SMP 3: Construct viable arguments and critique the reasoning of others.
- SMP 4: Model with mathematics.
- SMP 7: Look for and make use of structure.

Sequence of
Instruction

Activities Checklist

Engage



Begin by splitting the class into small groups (two to three students) and ask them to consider the following example:

INCLUDED IN THE STUDENT MANUAL

Task #5: Swimming Pool

You want to build a square swimming pool in your backyard. Let s denote the length of each side of the swimming pool (measured in feet). You plan to surround the pool by square border tiles, each of which is one foot by one foot (see figure).

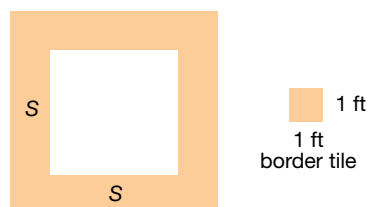

A teacher asks her students to find an expression for the number of tiles needed to surround such a square pool, and sees the following responses from her students:

$$4(s+1)$$

$$s^2$$

$$4s+4$$

$$2s+2(s+2)$$

$$4s$$

Is each mathematical model correct or incorrect? How do you know?

*Progressions for the Common Core State Standards in Mathematics (draft).
Grade 6-8, Middle School, Equations and Expressions.*

Explore



Ask the students to decide whether each answer is correct or incorrect. In addition, ask students to explain the method and logic (correct or incorrect) that each of these students used to determine their expression. What might each student have been thinking?

Explanation



The response $4(s+1)$ is correct. This student may have thought that for a given side, you need s tiles plus one additional tile for a corner, then multiply by four since there are four sides.

The response s^2 is not correct. This student calculated the area of the pool, not the number of tiles needed to create a border.

The response $4s+4$ is correct. This student may have realized each of the four sides needs s tiles, then added the four tiles needed for each corner.

The response $2s+2(s+2)$ is correct. This student may have thought about using s tiles on two of the sides (say top and bottom edges). Then the remaining two sides would require $s+2$ tiles each.

The response $4s$ is not correct. This student forgot to take into account the corners.

- Here it is important that students see the structure of each expression, and they are able to connect the structure of the expression to an interpretation. Breaking an expression down into parts so each has meaning is the primary goal of this activity.
- You might ask your students how they could determine or show that the three correct expressions are equivalent while the two incorrect expressions are not equivalent to the correct answer.

Practice Together / in Small Groups / Individually

Give each group a large piece of paper that they can write on and post on the wall. Have students work on the following examples and write their answers on the large piece of paper.



INCLUDED IN THE STUDENT MANUAL

Task #6: Smartphones

Suppose p and q represent the price (in dollars) of a 64GB and a 32GB smartphone, respectively, where $p > q$. Interpret each of the expressions in terms of money and smartphones. Then, if possible, determine which of the expressions in each pair is larger.

- $p+q$ and $2q$
- $p+0.08p$ and $q+0.08q$
- $600-p$ and $600-q$

Task #7: University Population

Let x and y denote the number male and female students, respectively, at a university, where $x < y$. If possible, determine which of the expressions in each pair is larger? Interpret each of the expressions in terms of populations

- $x+y$ and $2y$
- $\frac{x}{x+y}$ and $\frac{y}{x+y}$
- $\frac{x-y}{2}$ and $\frac{x}{x+y}$



Evaluate Understanding

After groups have finished with this activity and posted their answers around the room, call on various groups to share their answers and explanations. Be prepared to ask guiding questions with regard to interpreting the practical meaning of each of the expressions.

Closing Activity



Have the students multiply $\frac{x}{2} + \frac{3}{4}$ by 4.

The result should be $2x+3$ (or its equivalent).

Have the students determine if $2x+3$ is an equivalent expression to $\frac{x}{2} + \frac{3}{4}$ and support their reasoning with viable arguments. Students are to share, discuss and modify their arguments with another student.

Have each pair of students share their combined/modified arguments with the class and provide an expression equivalent to $2x+3$ that has not been previously presented.

Adapted from <http://www.illustrativemathematics.org/illustrations/543>

Commentary for the Teacher:

The purpose of this task is to directly address a common misconception held by many students who are learning to solve equations. Because a frequent strategy for solving an equation with fractions is to multiply both sides by a common denominator (so all the coefficients are integers), students often forget why this is an “allowable” move

in an equation and try to apply the same strategy when they see an expression. Two expressions are equivalent if they have the same value no matter what the value of the variables in them. After learning to transform expressions and equations into equivalent expressions and equations, it is easy to forget the original definition of equivalent expressions and mix up which transformations are allowed for expressions and which are allowed for equations.

INCLUDED IN THE STUDENT MANUAL

Independent Practice:

For each pair of expressions below, without substituting in specific values, determine which of the expressions in the given pairs is larger. Explain your reasoning in a sentence or two.

- $5+t^2$ and $3-t^2$
- $\frac{15}{x^2+6}$ and $\frac{15}{x^2+7}$
- $(s^2+2)(s^2+1)$ and $(s^2+4)(s^2+3)$
- $\frac{8}{k^2+2}$ and k^2+2

Resources/Instructional Materials Needed:

Chart paper

Notes:

Algebraic Expressions

Lesson 5 of 7

Constructing Equivalent Expressions

Description:

Students will begin this lesson by engaging in a task on developing expressions for a particular geometric pattern. This lesson will strengthen the ability of students to compare expressions presented in different forms and determine equivalency.

Georgia Standards of Excellence Addressed:

- MGSE9-12.A.SSE.3: Choose and produce an equivalent form of an expression to reveal and explain properties of the quantity represented by the expression.
- MGSE9-12.F.IF.8: Write a function defined by an expression in different but equivalent forms to reveal and explain different properties of the function.

Standard(s) for Mathematical Practice Emphasized:

- SMP 1: Make sense of problems and persevere in solving them.
- SMP 3: Construct viable arguments and critique the reasoning of others.
- SMP 7: Look for and make use of structure.
- SMP 8: Look for and express regularity in repeated reasoning.

Sequence of Instruction	Activities Checklist
--------------------------------	-----------------------------

Engage

Task #8: Sidewalk Patterns

Sidewalk Patterns that can be found at the Shell Center website

<http://map.mathshell.org/materials/tasks.php?taskid=254&subpage=apprentice> and on the next page.

- Ask students to complete the grid on page one of the task, and have volunteers share their results.
- Explain that we wish to construct a large square in accordance with this pattern. How many white blocks would you need? How many black blocks?

INCLUDED IN THE STUDENT MANUAL

Task #8: Sidewalk Patterns

Sidewalk Patterns

In Prague some sidewalks are made of small square blocks of stone.

The blocks are in different shades to make patterns that are in various sizes.

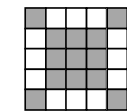

Pattern #1

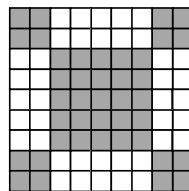

Pattern #2

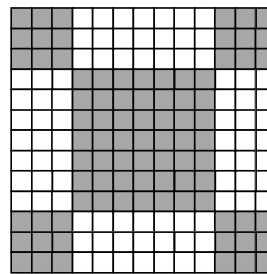

Pattern #3

Draw the next pattern in this series.

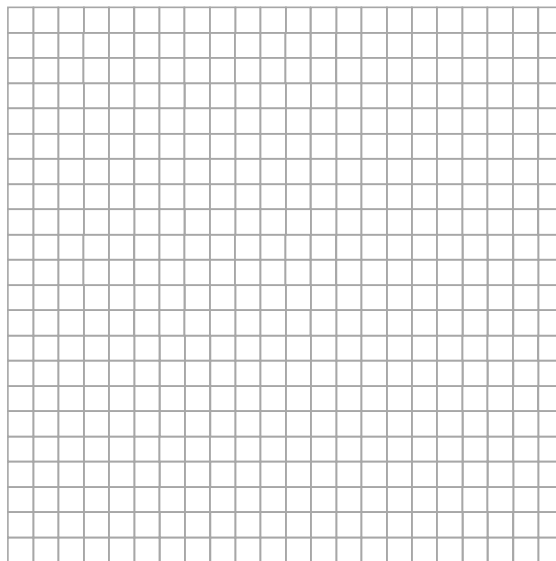

Pattern #4

INCLUDED IN THE STUDENT MANUAL

1. Complete the table below

Pattern number, n	1	2	3	4
Number of white blocks	12	40		
Number of gray blocks	13			
Total number of blocks	25			

2. What do you notice about the number of white blocks and the number of gray blocks?

3. The total number of blocks can be found by squaring the number of blocks along one side of the pattern.

a. Fill in the blank spaces in this list.

$25 = 5^2$ $81 = \underline{\hspace{2cm}}$ $169 = \underline{\hspace{2cm}}$ $289 = 17^2$

b. How many blocks will pattern #5 need? _____

c. How many blocks will pattern # n need? _____

4. a. If you know the total number of blocks in a pattern you can work out the number of white blocks in it. Explain how you can do this.

b. Pattern # 6 has a total of 625 blocks.
How many white blocks are needed for pattern #6? _____
Show how you figured this out.

Explore



- Split students into small groups (two to three students)
- Ask them to make sense of the problem and complete page two of the task together. They should construct viable arguments for their choices and critique the reasoning of their partner.
- When the group completes the task, ask them to write their answer for part 3c on a large piece of sticky paper.
- After all groups have finished, ask each to post their answer to 3c on the wall.
- Ask each group to decide which answers are correct.
- Ask a group that has the correct answer to explain how they found their expression.
- Ask if another group solved the task differently, and how that was reflected in the structure of their expression, and connect back to the ideas discussed with the pool tiles from the previous lesson.
- If any answers were incorrect, ask how you could prove their expression is not the same as one of the correct answers.

Guiding questions:

- What does it mean for expressions to be equivalent?
- How can you prove that two expressions are not equivalent?

Explanation

At this point review the general concept of what it means for two expressions to be equivalent; namely two expressions are equivalent if they have the same value for every possible value(s) you substitute in for each of the variable(s). Stress that if you try one value and see the output is the same, that is not enough to claim the expressions are the same for ALL values you could substitute into the expression. For example:

- (x^2+y^2) and $(x+y)^2$ have the same value if you substitute in $x=0$ and $y=2$ into both expressions (you get 4). However you need to show this for all possible pairs of values you could substitute for x and y . Thus, since $x=1$ and $y=1$ give a value of 2 in the first expression and a value of 4 in the second, these two expressions are not equivalent.
- Showing expressions are not equivalent is easier than showing two expressions are equivalent since you presumably need to check all possible values you could substitute.
- You could ask students to think of other possible ways you might determine whether these two expressions are equivalent. Some students might explain you could use algebra to expand the second expression and get $x^2+2xy+y^2$ that is not the same as the first expression. You could use this as pre-assessment for distributing and collecting like terms covered in the next day's classes.

Practice Together / in Small Groups / Individually



Divide the class up into small groups to complete Task #9: Expression Pairs: Equivalent or Not? Which pairs of algebraic expressions are equivalent and which are not

equivalent. Ask them to specifically look for and make sense of the structure. If they believe the pair of expressions is not equivalent, ask them to provide values for the variable(s) that lead to different values when you evaluate.

If they believe they are equivalent, ask them to show or explain how they determined equivalence. For example, which properties of operations are being used (associative, commutative, and distributive)? You may need to review these properties with students.

Notice that some of the pairs highlight common student misconceptions.

INCLUDED IN THE STUDENT MANUAL

Task #9: Expression Pairs: Equivalent or Not?

- $a+(3-b)$ and $(a+3)-b$
- $2+\frac{k}{5}$ and $10+k$
- $(a-b)^2$ and a^2-b^2
- $3(z+w)$ and $3z+3w$
- $-a+2$ and $-(a+2)$
- $\frac{1}{(x+y)}$ and $\frac{1}{x} + \frac{1}{y}$
- x^2+4x^2 and $5x^2$
- $\sqrt{(x^2+y^2)}$ and $x+y$
- $bc-cd$ and $c(b-d)$
- $(2x)^2$ and $4x^2$
- $2x+4$ and $x+2$

(More pairs could be added here if students need more practice.)

Evaluate Understanding

After the groups have had the opportunity to determine which pairs of algebraic expressions are equivalent and which are not equivalent, ask the groups to share their answers. If they all agree on the answer to the first set of expressions, move to the next pair. If they do not agree, ask two of the groups that disagree to come to the board and demonstrate how they determined that the expressions were equivalent or not equivalent.

It is important to emphasize that if you ever forget whether $\frac{1}{(x+y)} = \frac{1}{x} + \frac{1}{y}$, you can always check by substituting some values. If the results are yield a false statement, clearly they are not equivalent. If the results are equivalent, then they still may not be equivalent for all values you substitute, so be careful.

It is also important to emphasize properties of operations with algebraic expressions that are exactly the same as the properties of operations on numerical expressions. We are not inventing new operations, rather extending previous understanding with numbers to algebraic expressions. Refrain from using gimmicks such as PEMDAS to tell students the order with which they MUST evaluate. When working with algebraic expressions, you still use distributive property just as with numbers.

To illustrate this point to teachers (you may not want to show this to students unless necessary), consider $7-2(3-8x)$. A student blindly recalling “PEMDAS” might simplify as

follows $7-2(3-8x)=7-2(-5x)=7+10x$ since P comes first. Or a student may think $n-2+5=n-7$ since you do A before S. While strictly interpreting PEMDAS would lead one to (incorrectly) say $8(5+1) = 8(5) + 8(1)$. You first need to add 5 and 1.

Closing Activity



INCLUDED IN THE STUDENT MANUAL

Task #10: Kitchen Floor Tiles

Fred has some colored kitchen floor tiles and wants to choose a pattern to make a border around white tiles. He generates patterns by starting with a row of four white tiles. He surrounds these four tiles with a border of colored tiles (Border 1). The design continues as shown below:

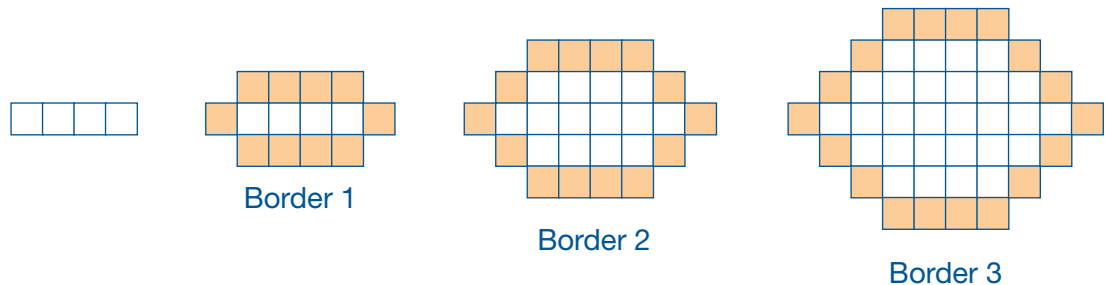

Fred writes the expression $4(b-1) + 10$ for the number of tiles in each border, where b is the border number, $b \geq 1$.

- Explain why Fred's expression is correct.
- Emma wants to start with five tiles in a row. She reasons, "Fred started with four tiles and his expression was $4(b-1) + 10$. So if I start with five tiles, the expression will be $5(b-1) + 10$. Is Emma's statement correct? Explain your reasoning.
- If Emma starts with a row of n tiles, what should the expression be?

Adapted from: <http://illustrativemathematics.org/illustrations/215>

Commentary for the Teacher:

The purpose of this task is for students to practice reading, analyzing, and constructing algebraic expressions, attending to the relationship between the form of an expression and the context from which it arises. The context here is intentionally thin; the point is not to provide a practical application to kitchen floors but to give a framework that imbues the expressions with an external meaning.

Analyzing and generalizing geometric patterns such as the one in this task may be familiar to students from work in previous grades, so part (a) may be a review of that process. It requires students to make use of the structure in the expression, to notice and express the regularity in the repeated geometric construction and to explain and justify the reasoning of others. Part (b) requires a deeper analysis of the expression, identifying the referents for its various parts. Students may still need guidance in writing the formula for part (c) since it introduces a second variable.

Possible Solution:

For Border 1, tiles are added above and below the original four tiles — a total of eight additional tiles — and a tile is added to each end of the row of original tiles — two additional tiles — for a total of 10 tiles.

For Border 2, we have four additional tiles needed to fill in the corners of the diagram (one tile for each corner gap), plus the original 10 tiles coming from the top and bottom rows of four tiles each and the two end tiles:

$$4+10 \text{ colored tiles in Border 2.}$$

For Border 3, there are now two tiles in each of the four corners, plus the same 10 tiles from the top, bottom and ends, so there are:

$$4(2)+10 \text{ colored tiles in Border 3.}$$

For Border 4, we have three tiles in each corner, for a total of:

$$4(3)+10 \text{ colored tiles in Border 4.}$$

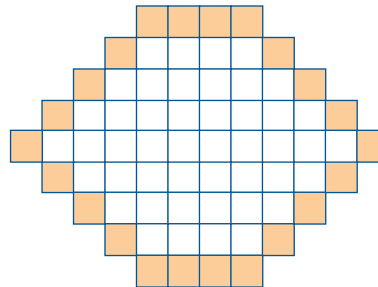

Border 4

The following table illustrates the pattern:

Border number	Number of tiles in the border
1	10
2	$4(1)+10$
3	$4(2)+10$
4	$4(3)+10$
<input type="checkbox"/>	
b	$4(b-1)+10$

In Border b there are $b-1$ extra tiles needed at each of the four corners, so the number of border tiles needed is given by Fred’s expression:

$$4(b-1)+10$$

- In part a, the number 10 comes from the top row of tiles, the bottom row of tiles, and the two tiles on the ends of the original four tiles. If Emma starts with five tiles, that number would change to 12 – 5 tiles above the originals — five tiles below the originals, and one tile on each end. Emma’s formula is not correct. She has incorrectly assumed that the 4 in Fred’s formula came from the number of tiles in the beginning row, when it actually comes from the number of corners in the diagram itself. Regardless of the number of tiles in the beginning row, there will always be “4” corners to be filled. If Emma wants a formula for the number of tiles in each border starting with five tiles in the original row, she could use:

$$t=4(b-1)+12$$

Algebraic Expressions

Lesson 6 of 7

Distributive Property

Description:

Students will begin this lesson with an engaging activity that will lead to an understanding of rewriting and interpreting expressions using the distributive property.

Georgia Standards of Excellence Addressed:

- MGSE9-12.A.SSE.1: Interpret expressions that represent a quantity in terms of its context.
- MGSE9-12-A.SSE.2: Use the structure of an expression to rewrite it in different equivalent forms. For example, see $x^4 - y^4$ as $(x^2)^2 - (y^2)^2$, thus recognizing it as a difference of squares that can be factored as $(x^2 - y^2)(x^2 + y^2)$.

Standard(s) for Mathematical Practice Emphasized:

- SMP 3: Construct viable arguments and critique the reasoning of others.
- SMP 4: Model with mathematics.

Sequence of
Instruction

Activities Checklist

Engage



Guess the Numbers on the Dice

Give a student a pair of dice. Tell the student you will deduce what the student rolled on the dice without seeing the dice.

Have the student roll the dice and ask them to:

- Multiply one of the numbers on the dice by 5.
- Add 8 to the product.
- Multiply the sum by 2.
- Add the number on the other die to the product.
- Give the teacher the result.

Subtract 16 from the student's final answer. The numbers on the dice are the two digits of the numeral of the resulting number.

Let the students discuss in groups and ask them to construct viable arguments on how this works. Have the students:

1. Reproduce the activity with their partner for another roll of the dice.
2. Verify that the process works.
3. Define x to be the number on one die and y the number on the other die.
4. Write an expression to represent the calculations followed during the activity.

5. Rewrite the expression.
6. Analyze why the activity works.

(Note: The expression is $(5x+8)(2)+y$ that simplifies to $10x+y+16$ and then subtracting 16 yields $10x+y=x(10)+y(1)$, and thus the ten's digit is the x and the one's digit is the y .)

Explore



Have students sketch a rectangle of any dimension on the dot paper provided, but

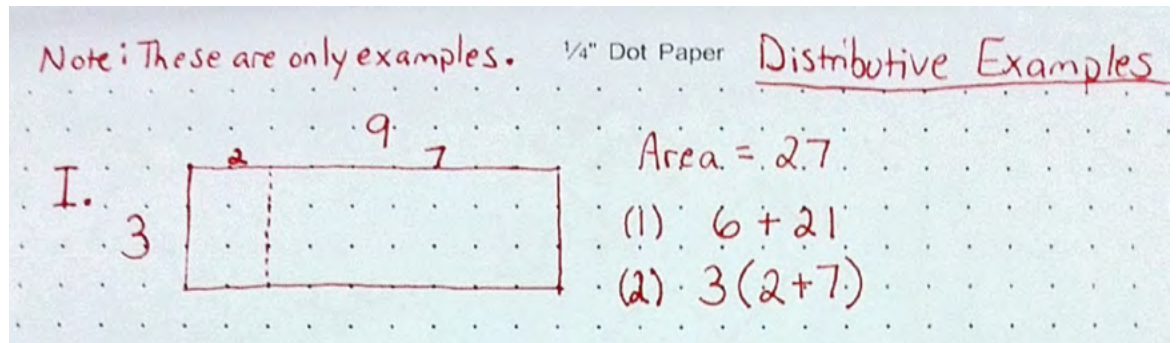

Example of Student Work

make sure each vertex is on a dot (ex: 3×9).

- Have them label the length and width of the rectangle.
- Have them calculate the area of the rectangle (ex: 27).
- Tell them to draw a vertical line that cuts the rectangle into two pieces.

Now, the rectangle is two separate rectangles, say A and B.

- Have them label the dimensions of both rectangles A and B (ex: 3×2 and 3×7).

Now, write the area of the original rectangle in two ways: (1) as the sum of the areas of A and B (ex: $6+21$), and (2) as the product of one length times width (ex: $3 \cdot (2+7)$).

The focus here is to get them comfortable with expressing area in these two ways by modeling the mathematics.

Now, have the students draw another rectangle where the upper left and lower left vertices are the only vertices on dots.

- Ask them how they should label the length and width (ex: “3” and “x”).
- Calculate the area of the rectangle (ex: $3x$).
- Now, draw a vertical line that cuts the rectangle into two pieces.

Now, the rectangle is two separate rectangles, say A and B.

- Have them label the dimensions of both rectangles A and B (ex: 3 by 2 and 3 by $(x-2)$).

Now, write the area of the original rectangle in two ways: (1) as the sum of the areas of A and B (ex: $6+3(x-2)$), and (2) as the product of one length times width (ex: $3(2+(x-2))$).

Continue with variations of rectangles (some are provided on the example sheet below getting students familiar with writing areas in two ways.

II. 3 2 x $x-2$ Area = $3x$
 (1) $6 + 3(x-2)$
 (2) $3(2+(x-2))$

III. y 2 x $x-2$ Area = xy
 (1) $2y + y(x-2)$
 (2) $y(2+(x-2))$

IV. y 2 x $x-2$ Area = xy
 (1) $2y + y(x-2)$
 (2) $y(2+(x-2))$

V. y z x $x-z$ Area = xy
 (1) $zy + y(x-z)$
 (2) $y(z+(x-z))$

Example of Student Work

Explanation



Have students work through the task. Provide support to students as needed.

INCLUDED IN THE STUDENT MANUAL

Task #11: Distributive Property Using Area

<http://illuminations.nctm.org/uploadedFiles/Content/Lessons/Resources/6-8/distrib-AS-AreaForDistrib.pdf>.

INCLUDED IN THE STUDENT MANUAL

Distributive Property Using Area

NAME _____

Write the expression that represents the area of each rectangle.

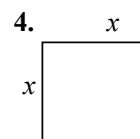
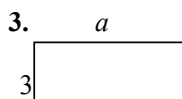
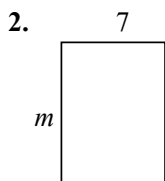
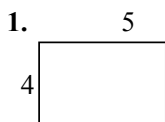

Find the area of each box in the pair.

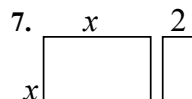
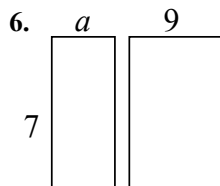
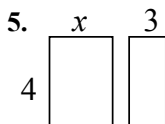

Write the expression that represents the total length of each segment.



Write the area of each rectangle as the product of *length* \times *width* and also as a sum of the areas of each box.

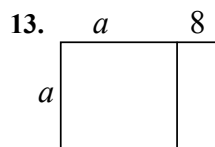
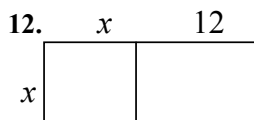
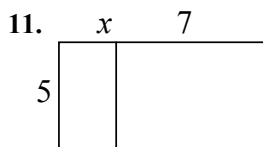

AREA AS PRODUCT	AREA AS SUM
$5(x+7)$	$5x+35$

AREA AS PRODUCT	AREA AS SUM

AREA AS PRODUCT	AREA AS SUM

This process of writing these products as a sum uses the **distributive property**.

Use the distributive property to re-write each expression as a sum. You may want to draw a rectangle on a separate page to follow the technique above.

14. $4(x+7) =$ _____

15. $7(x-3) =$ _____

16. $-2(x+4) =$ _____

17. $x(x+9) =$ _____

18. $a(a-1) =$ _____

19. $3m(m+2) =$ _____

20. $-4(a-4) =$ _____

21. $a(a-12) =$ _____

The first section introduces students to the idea of writing the area of a rectangle as an expression of the length \times width, even when one or more dimensions may be represented by a variable.

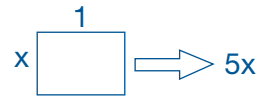

In the next section students learn to represent the length of a segment consisting of two parts as a *sum*.



The key section is next, having students represent the area of each rectangle *two ways* (modeling the mathematics) to distribute the common factor among all parts of the expression in parentheses.

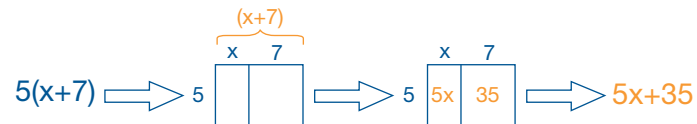

Practice Together / in Small Groups / Individually

Work through the task:

INCLUDED IN THE STUDENT MANUAL

Task #12: Factoring a Common Factor Using Area

This can be found on the next page and at:

<http://illuminations.nctm.org/uploadedFiles/Content/Lessons/Resources/6-8/distrib-AS-AreaForDistrib.pdf>.

INCLUDED IN THE STUDENT MANUAL

Factoring a Common Factor Using Area

NAME _____

Fill in the missing information for each: dimensions, area as product, and area as sum

<p>1.</p> <table border="1" style="margin-left: 20px; border-collapse: collapse;"> <tr> <td style="width: 20px;"></td> <td style="width: 40px; text-align: center;">x</td> <td style="width: 40px; text-align: center;">6</td> </tr> <tr> <td style="width: 20px; text-align: center;">2</td> <td style="width: 40px; text-align: center;"><input type="text"/></td> <td style="width: 40px; text-align: center;"><input type="text"/></td> </tr> </table> <p>_____</p> <p>_____</p>		x	6	2	<input type="text"/>	<input type="text"/>	<p>2.</p> <table border="1" style="margin-left: 20px; border-collapse: collapse;"> <tr> <td style="width: 20px;"></td> <td style="width: 40px; text-align: center;"><input type="text"/></td> <td style="width: 40px; text-align: center;"><input type="text"/></td> </tr> <tr> <td style="width: 20px; text-align: center;">5</td> <td style="width: 40px; text-align: center;">$5x$</td> <td style="width: 40px; text-align: center;">20</td> </tr> </table> <p>_____</p> <p>_____</p>		<input type="text"/>	<input type="text"/>	5	$5x$	20	<p>3.</p> <table border="1" style="margin-left: 20px; border-collapse: collapse;"> <tr> <td style="width: 20px;"></td> <td style="width: 40px; text-align: center;"><input type="text"/></td> <td style="width: 40px; text-align: center;">8</td> </tr> <tr> <td style="width: 20px; text-align: center;"><input type="text"/></td> <td style="width: 40px; text-align: center;">$6x$</td> <td style="width: 40px; text-align: center;">48</td> </tr> </table> <p>_____</p> <p>_____</p>		<input type="text"/>	8	<input type="text"/>	$6x$	48	<p>4.</p> <table border="1" style="margin-left: 20px; border-collapse: collapse;"> <tr> <td style="width: 20px;"></td> <td style="width: 40px; text-align: center;">x</td> <td style="width: 40px; text-align: center;"><input type="text"/></td> </tr> <tr> <td style="width: 20px; text-align: center;"><input type="text"/></td> <td style="width: 40px; text-align: center;">$10x$</td> <td style="width: 40px; text-align: center;">30</td> </tr> </table> <p>_____</p> <p>_____</p>		x	<input type="text"/>	<input type="text"/>	$10x$	30
	x	6																									
2	<input type="text"/>	<input type="text"/>																									
	<input type="text"/>	<input type="text"/>																									
5	$5x$	20																									
	<input type="text"/>	8																									
<input type="text"/>	$6x$	48																									
	x	<input type="text"/>																									
<input type="text"/>	$10x$	30																									

Fill in the missing dimensions from the expression given.

<p>5. $5x + 35 = 5(\text{_____})$</p> <table border="1" style="margin-left: 20px; border-collapse: collapse;"> <tr> <td style="width: 20px;"></td> <td style="width: 40px; text-align: center;"><input type="text"/></td> <td style="width: 40px; text-align: center;"><input type="text"/></td> </tr> <tr> <td style="width: 20px; text-align: center;"><input type="text"/></td> <td style="width: 40px; text-align: center;"><input type="text"/></td> <td style="width: 40px; text-align: center;"><input type="text"/></td> </tr> </table>		<input type="text"/>	<input type="text"/>	<input type="text"/>	<input type="text"/>	<input type="text"/>	<p>6. $2x + 12 = 2(\text{_____})$</p> <table border="1" style="margin-left: 20px; border-collapse: collapse;"> <tr> <td style="width: 20px;"></td> <td style="width: 40px; text-align: center;"><input type="text"/></td> <td style="width: 40px; text-align: center;"><input type="text"/></td> </tr> <tr> <td style="width: 20px; text-align: center;"><input type="text"/></td> <td style="width: 40px; text-align: center;"><input type="text"/></td> <td style="width: 40px; text-align: center;"><input type="text"/></td> </tr> </table>		<input type="text"/>	<input type="text"/>	<input type="text"/>	<input type="text"/>	<input type="text"/>	<p>7. $3x - 21 = \text{_____}(\text{_____})$</p> <table border="1" style="margin-left: 20px; border-collapse: collapse;"> <tr> <td style="width: 20px;"></td> <td style="width: 40px; text-align: center;"><input type="text"/></td> <td style="width: 40px; text-align: center;"><input type="text"/></td> </tr> <tr> <td style="width: 20px; text-align: center;"><input type="text"/></td> <td style="width: 40px; text-align: center;"><input type="text"/></td> <td style="width: 40px; text-align: center;"><input type="text"/></td> </tr> </table>		<input type="text"/>	<input type="text"/>	<input type="text"/>	<input type="text"/>	<input type="text"/>
	<input type="text"/>	<input type="text"/>																		
<input type="text"/>	<input type="text"/>	<input type="text"/>																		
	<input type="text"/>	<input type="text"/>																		
<input type="text"/>	<input type="text"/>	<input type="text"/>																		
	<input type="text"/>	<input type="text"/>																		
<input type="text"/>	<input type="text"/>	<input type="text"/>																		
<p>8. $7x - 21 = \text{_____}(\text{_____})$</p> <table border="1" style="margin-left: 20px; border-collapse: collapse;"> <tr> <td style="width: 20px;"></td> <td style="width: 40px; text-align: center;"><input type="text"/></td> <td style="width: 40px; text-align: center;"><input type="text"/></td> </tr> <tr> <td style="width: 20px; text-align: center;"><input type="text"/></td> <td style="width: 40px; text-align: center;"><input type="text"/></td> <td style="width: 40px; text-align: center;"><input type="text"/></td> </tr> </table>		<input type="text"/>	<input type="text"/>	<input type="text"/>	<input type="text"/>	<input type="text"/>	<p>9. $-3x - 15 = -3(\text{_____})$</p> <table border="1" style="margin-left: 20px; border-collapse: collapse;"> <tr> <td style="width: 20px;"></td> <td style="width: 40px; text-align: center;"><input type="text"/></td> <td style="width: 40px; text-align: center;"><input type="text"/></td> </tr> <tr> <td style="width: 20px; text-align: center;"><input type="text"/></td> <td style="width: 40px; text-align: center;"><input type="text"/></td> <td style="width: 40px; text-align: center;"><input type="text"/></td> </tr> </table>		<input type="text"/>	<input type="text"/>	<input type="text"/>	<input type="text"/>	<input type="text"/>	<p>10. $-5x + 45 = \text{_____}$</p> <table border="1" style="margin-left: 20px; border-collapse: collapse;"> <tr> <td style="width: 20px;"></td> <td style="width: 40px; text-align: center;"><input type="text"/></td> <td style="width: 40px; text-align: center;"><input type="text"/></td> </tr> <tr> <td style="width: 20px; text-align: center;"><input type="text"/></td> <td style="width: 40px; text-align: center;"><input type="text"/></td> <td style="width: 40px; text-align: center;"><input type="text"/></td> </tr> </table>		<input type="text"/>	<input type="text"/>	<input type="text"/>	<input type="text"/>	<input type="text"/>
	<input type="text"/>	<input type="text"/>																		
<input type="text"/>	<input type="text"/>	<input type="text"/>																		
	<input type="text"/>	<input type="text"/>																		
<input type="text"/>	<input type="text"/>	<input type="text"/>																		
	<input type="text"/>	<input type="text"/>																		
<input type="text"/>	<input type="text"/>	<input type="text"/>																		

This process of writing a sum or difference as the product of factors is called **factoring**.

Factor these:

11. $4x - 16 = \text{_____}$

12. $-7x - 35 = \text{_____}$

13. $9x - 81 = \text{_____}$

14. $4x + 18 = \text{_____}$

Give the students questions similar to the following.

- a. Show why " $2(x+y)$ " and " $2x+2y$ " are the same.
- b. Rewrite " $3(x+z)$."
- c. Rewrite " $a(p+q+r)$."
- d. Rewrite " $5(2x+3y+z)$."

Evaluate Understanding

Have students independently complete Task #13: Distributive Property.

INCLUDED IN THE STUDENT MANUAL

Task #13: Distributive Property

Are the expressions equivalent? Sketch and simplify to prove. If the two expressions are not equal write the correct equivalence.

1. $3(x+3)$ and $3x+6$

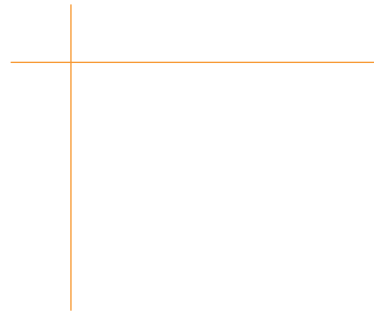

2. $6(y+1)$ and $6y+6$



3. $x(x+4)$ and x^2+4

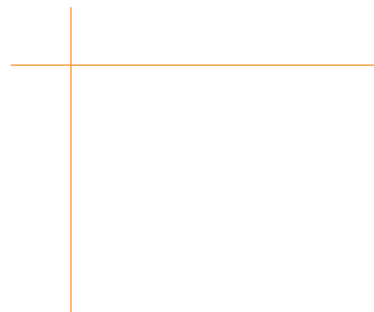

4. $y(x+2)$ and $xy+2y$



5. $x(x+y+2)$ and $x^2+xy+2x$



6. $2x(x+3)$ and $2x^2+6x$

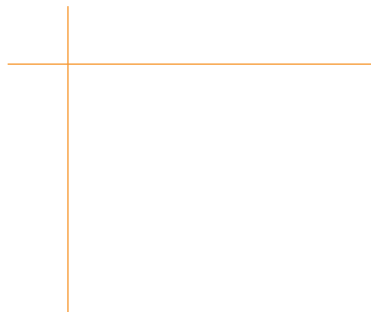

Distribute the following. Use a sketch or just distribute if you can.

1. $3(x+2)$

2. $4(y-1)$

3. $x(x+6)$

4. $x(y+4)$

5. $3x(x+y-1)$

Closing Activity

Write, 49, on a slip of paper.

- Fold the paper and give it to someone to hold for safekeeping.
- Ask a volunteer to toss a pair of dice and write down the results of the following computations:
 - Multiply the two top numbers on the dice.
 - Multiply the two bottom numbers on the dice.
 - Multiply the top number on one die by the bottom number on the other die.
 - Multiply the other pair of top and bottom numbers.
 - Now, add up the four products and announce the sum.
- Then, ask the person with the folded slip of paper to unfold it and read your prediction.

Tell the students that this trick always works because the sum of the two numbers on any pair of opposite faces is always seven.

Now, if we let a and b be the numbers that show after the dice are tossed, what are the products going to be from the steps given? (answer: ab , $(7-a)$, $(7-b)$, $a(7-b)$, and $b(7-a)$)

Now, have the students add the products and simplify to show that it must always equal 49.

Independent Practice:

For extra practice, teachers may have students complete the final two pages of the activity found at:

<https://illuminations.nctm.org/uploadedFiles/Content/Lessons/Resources/6-8/distrib-AS-AreaForDistrib.pdf>.

Resources/Instructional Materials Needed:

Dot Paper

Teacher Note: The emphasis in this lesson is to get students comfortable with the area model for the distributive property, as it will be used in following unit(s).

Notes:

Algebraic Expressions

Lesson 7 of 7

Formative Assessment Lesson: Interpreting Algebraic Expressions

Description:

This lesson is intended to help teachers assess how well students are able to translate between words, symbols, tables, and area representations of algebraic expressions. It is designed to identify and support students who have difficulty in these concepts.

From the Shell Center Formative Assessment Lesson: Interpreting Algebraic Expressions

Georgia Standards of Excellence Addressed:

- MGSE9-12.A.SSE.1: Interpret expressions that represent a quantity in terms of its context.
- MGSE9-12.A.SSE.2: Use the structure of an expression to rewrite it in different equivalent forms. For example, see $x^4 - y^4$ as $(x^2)^2 - (y^2)^2$, thus recognizing it as a difference of squares that can be factored as $(x^2 - y^2)(x^2 + y^2)$.

Standard(s) for Mathematical Practice Emphasized:

- SMP 2: Reason abstractly and quantitatively.
- SMP 7: Look for and make use of structure.

The following *Formative Assessment Lesson* is a classroom-ready lesson included to help teachers assess and improve students' understanding of mathematical concepts and skills and their ability to use the mathematical process readiness indicators critical for college readiness.

Research has shown that formative assessment, as embodied in the following lesson, is a powerful way to improve student learning and performance. This approach first allows students to demonstrate their prior understandings and abilities in employing the mathematical processes, and then resolve their own difficulties and misconceptions through structured discussion. This results in more secure long-term learning, reducing the need for re-teaching that otherwise takes so much classroom time.

Many often ask, why don't students just remember the procedures they have been taught and practiced? The fact is, that approach works fine in the short term but, as every teacher knows, if procedural knowledge is not underpinned by conceptual understanding, students will quickly forget "how to do it."

Read more about the *Formative Assessment Lesson* rationale, structure, and philosophy using the *Brief Guide for Teachers and Administrators* that can be found at <http://map.mathshell.org/materials/index.php>.

CONCEPT DEVELOPMENT

Mathematics Assessment Project
CLASSROOM CHALLENGES
A Formative Assessment Lesson

Interpreting Algebraic Expressions

Mathematics Assessment Resource Service
University of Nottingham & UC Berkeley
Beta Version

For more details, visit: <http://map.mathshell.org>
© 2012 MARS, Shell Center, University of Nottingham
May be reproduced, unmodified, for non-commercial purposes under the Creative Commons license
detailed at <http://creativecommons.org/licenses/by-nc-nd/3.0/> - all other rights reserved

BEFORE THE LESSON

Assessment task: *Interpreting Expressions* (10 minutes)

Have the students do this task in class or for homework a day or more before the formative assessment lesson. This will give you an opportunity to assess the work and to find out the kinds of difficulties students have with it. You will then be able to target your help more effectively in the follow-up lesson.

Give each student a copy of *Interpreting Expressions*. Introduce the task briefly and help students to understand what they are being asked to do.

I want you to spend ten minutes working individually on this task.

Don't worry too much if you can't understand or do everything. There will be a lesson [tomorrow] with a similar task that will help you improve.

It is important that, as far as possible, students are allowed to answer the questions without assistance.

If students are struggling to get started, ask them questions that help them understand what is required, but do not do the task for them.

Assessing students' responses

Collect students' responses to the task. Make some notes about what their work reveals about their current levels of understanding. The purpose of doing this is to forewarn you of the difficulties students will experience during the lesson itself, so that you may prepare carefully.

We suggest that you do not score students' papers. The research shows that this will be counterproductive, as it will encourage students to compare their scores and distract their attention from what they can do to improve their mathematics.

Instead, help students to make further progress by summarizing their difficulties as a list of questions. Some suggestions for these are given on the next page. These have been drawn from common difficulties observed in trials of this lesson unit.

We suggest that you write your own lists of questions, based on your own students' work, using the ideas in the *Common issues* table on the next page. You may choose to write questions on each student's work. If you do not have time to do this, you could write a few questions that will help the majority of students. These can then be displayed on the board at the end of the lesson.

Interpreting Expressions

1. Write algebraic expressions for each of the following:

a. Multiply n by 5 then add 4. _____

b. Add 4 to n then multiply by 5. _____

c. Add 4 to n then divide by 5. _____

d. Multiply n by n then multiply by 3. _____

e. Multiply n by 3 then square the result. _____

2. The equations below were created by students who were asked to write equivalent expressions on either side of the equals sign.
Imagine you are a teacher. Your job is to decide whether their work is right or wrong. If you see an equation that is false, then:

a. Cross out the expression on the right and replace it with an expression that is equivalent to the one on the left.

b. Explain what is wrong, using words or diagrams.

$$2(n + 3) = 2n + 3$$

$$\frac{10n - 5}{5} = 2n - 1$$

$$(5n)^2 = 5n^2$$

$$(n + 3)^2 = n^2 + 3^2 = n^2 + 9$$

Common issues:

Suggested questions and prompts:

<p>Student writes expressions left to right, showing little understanding of the order of operations implied by the symbolic representation.</p> <p>For example:</p> <p>Q1a Writes $n \times 5 + 4$ (not incorrect). Q1b Writes $4 + n \times 5$. Q1c Writes $4 + n \div 5$. Q1d Writes $n \times n \times 3$.</p>	<ul style="list-style-type: none"> • Can you write answers to the following? $4 + 1 \times 5$ $4 + 2 \times 5$ $4 + 3 \times 5$ • Check your answers with your calculator. How is your calculator working these out? • So what does $4 + n \times 5$ mean? Is this the same as Q1b?
<p>Student does not construct parentheses correctly or expands them incorrectly.</p> <p>For example:</p> <p>Q1b Writes $4 + n \times 5$ instead of $5(n + 4)$. Q1c Writes $4 + n \div 5$ instead of $\frac{4+n}{5}$. Q2 $2(n+3) = 2n+3$ is counted as correct. Q2 $(5n)^2 = 5n^2$ is counted as correct. Q2 $(n+3)^2 = n^2 + 3^2$ is counted as correct.</p>	<ul style="list-style-type: none"> • Which one of the following is the odd one out and why? • Think of a number, add 3, and then multiply your answer by 2. • Think of a number, multiply it by 2, and then add 3. • Think of a number, multiply it by 2, and then add 6.
<p>Student identifies errors but does not give explanations.</p> <p>In question 2, there are corrections to the first, third, and fourth statements, but no explanation or diagram is used to explain why they are incorrect.</p>	<ul style="list-style-type: none"> • How would you write down expressions for these areas? • Can you do this in different ways?

SUGGESTED LESSON OUTLINE

Interactive whole-class introduction (10 minutes)

Give each student a mini-whiteboard, pen and eraser. Hold a short question and answer session. If students show any incorrect answers, write the correct answer on the board and discuss any problems.

On your mini-whiteboards, show me an algebraic expression that means:

Multiply n by 4, and then add 3 to your answer. $4n + 3$

Add 3 to n , and then multiply your answer by 4. $4(3 + n)$

Add 5 to n , and then divide your answer by 3. $\frac{n + 5}{3}$

Multiply n by n , and then multiply your answer by 5. $5n^2$

Multiply n by 5, and then square your answer. $(5n)^2$

Collaborative activity: matching expressions and words (15 minutes)

The first activity is designed to help students interpret symbols and realize that the way the symbols are written defines the order of operations.

Organize students into groups of two or three. Display the projector resource P-1, *Matching Expressions and Words*. Note that one of the algebraic expressions on the slide does not have a match in words. This is deliberate! It is to help you explain the task to students.

Model the activity briefly for students, using the examples on the projector resource.

I am going to give each group two sets of cards, one with expressions written in algebra, and the other with words.

Take it in turns to choose an expression and find the words that match it. [$4(n + 2)$ matches 'Add 2 to n then multiply by 4'; $2(n + 4)$ matches 'Add 4 to n then multiply by 2'.]

When you are working in groups, you should place these cards side by side on the table and explain how you know that they match.

If you cannot find a matching card, then you should write your own. Use the blank cards provided. [$4n + 2$ does not match any of the word cards shown on the slide. The word card 'Multiply n by two, then add four' does not match any of the expressions.]

Give a copy of *Card Set A: Expressions* and *Card Set B: Words* to each small group. Support students in making matches and explaining their decisions.

As they do this, encourage students to speak the algebraic expressions out loud. Students may not be used to 'talking algebra' and may not know how to say what is written, or may do so in ways that create ambiguities.

For example, the following conversation between a teacher and pupil is fairly typical:

Teacher: Tell me in words what this one says. [Teacher writes: $3 + \frac{n}{2}$.]

Pupil: Three add n divided by two.

Teacher: How would you read this one then? [Teacher writes: $\frac{(3 + n)}{2}$.]

Pupil: Three add n divided by two. Oh, but in the second one you are dividing it all by two.

Teacher: So can you try reading the first one again, so it sounds different from the second one?

Pupil: Three add... [pause] ..n divided by two [said quickly]. Or n divided by two, then add three.

Card Set A: Expressions	
E1 $\frac{n+6}{2}$	E2 $3n^2$
E3 $2n+12$	E4 $2n+6$
E5 $2(n+3)$	E6 $\frac{n}{2}+6$
E7 $(3n)^2$	E8 $(n+6)^2$
E9 $n^2+12n+36$	E10 $3+\frac{n}{2}$
E11 n^2+6	E12 n^2+6^2
E13	E14

Card Set B: Words	
W1 Multiply n by two, then add six.	W2 Multiply n by three, then square the answer
W3 Add six to n then multiply by two.	W4 Add six to n then divide by two
W5 Add three to n then multiply by two.	W6 Add six to n then square the answer
W7 Multiply n by two then add twelve	W8 Divide n by two then add six.
W9 Square n , then add six	W10 Square n , then multiply by nine
W11	W12
W13	W14

Students will need to make word cards to match E10: $3+\frac{n}{2}$ and E12: n^2+6^2 .

They will also need to make expression cards to match W3: *Add 6 to n , then multiply by 2* and W10: *Square n , then multiply by 9.*

Some students may notice that some expressions are equivalent, for example $2(n+3)$ and $2n+6$. You do not need to comment on this now: when the *Card Set C: Tables* is given out, students will notice this for themselves.

Collaborative activity: matching expressions, words, and tables (15 minutes)

Card Set C: Tables will make students substitute numbers into the expressions and will alert them to the fact that different expressions are equivalent.

Give each small group of students a copy of *Card Set C: Tables* and ask students to match these to the card sets already on the table. Some tables have numbers missing: students will need to write these in.

Encourage students to use strategies for matching. There are shortcuts that will help to minimize the work. For example, some may notice that:

Card Set C: Tables																					
T1 <table border="1"> <tr><td>n</td><td>1</td><td>2</td><td>3</td><td>4</td></tr> <tr><td>Ans</td><td>14</td><td>16</td><td>18</td><td>20</td></tr> </table>	n	1	2	3	4	Ans	14	16	18	20	T2 <table border="1"> <tr><td>n</td><td>1</td><td>2</td><td>3</td><td>4</td></tr> <tr><td>Ans</td><td></td><td></td><td>81</td><td>144</td></tr> </table>	n	1	2	3	4	Ans			81	144
n	1	2	3	4																	
Ans	14	16	18	20																	
n	1	2	3	4																	
Ans			81	144																	
T3 <table border="1"> <tr><td>n</td><td>1</td><td>2</td><td>3</td><td>4</td></tr> <tr><td>Ans</td><td></td><td>10</td><td>15</td><td>22</td></tr> </table>	n	1	2	3	4	Ans		10	15	22	T4 <table border="1"> <tr><td>n</td><td>1</td><td>2</td><td>3</td><td>4</td></tr> <tr><td>Ans</td><td>3</td><td></td><td>27</td><td>48</td></tr> </table>	n	1	2	3	4	Ans	3		27	48
n	1	2	3	4																	
Ans		10	15	22																	
n	1	2	3	4																	
Ans	3		27	48																	
T5 <table border="1"> <tr><td>n</td><td>1</td><td>2</td><td>3</td><td>4</td></tr> <tr><td>Ans</td><td></td><td></td><td>81</td><td>100</td></tr> </table>	n	1	2	3	4	Ans			81	100	T6 <table border="1"> <tr><td>n</td><td>1</td><td>2</td><td>3</td><td>4</td></tr> <tr><td>Ans</td><td></td><td>10</td><td>12</td><td>14</td></tr> </table>	n	1	2	3	4	Ans		10	12	14
n	1	2	3	4																	
Ans			81	100																	
n	1	2	3	4																	
Ans		10	12	14																	
T7 <table border="1"> <tr><td>n</td><td>1</td><td>2</td><td>3</td><td>4</td></tr> <tr><td>Ans</td><td></td><td>4</td><td></td><td>5</td></tr> </table>	n	1	2	3	4	Ans		4		5	T8 <table border="1"> <tr><td>n</td><td>1</td><td>2</td><td>3</td><td>4</td></tr> <tr><td>Ans</td><td>6.5</td><td>7</td><td>7.5</td><td>8</td></tr> </table>	n	1	2	3	4	Ans	6.5	7	7.5	8
n	1	2	3	4																	
Ans		4		5																	
n	1	2	3	4																	
Ans	6.5	7	7.5	8																	

Since $2(n+3)$ is an even number, we can just look at tables with even numbers in them.

Since $(3n)^2$ is a square number, we can look for tables with only square numbers in them.

Students will notice that there are fewer tables than expressions. This is because some tables match more than one expression. Allow students time to discover this for themselves. As they do so, encourage them to test that they match for all n . This is the beginning of a generalization.

Do $2(n+3)$ and $2n+6$ always give the same answer when $n = 1, 2, 3, 4, 5$?

What about when $n = 3246$, or when $n = -23$, or when $n = 0.245$?

Check on your calculator.

Can you explain how you can be sure?

This last question is an important one, and will be followed up in the next part of the lesson.

It is important not to rush the learning. At about this point, some lessons run out of time. If this happens, ask pupils to stack their cards in order, so that matching cards are grouped together, and fasten them with a paper clip. Ask students to write their names on an envelope, and store the matched cards in it. These envelopes can be reissued in the next lesson.

Collaborative activity: matching expressions, words, tables, and areas (15 minutes)

The *Card Set D: Areas* will help students to understand *why* the different expressions match the same tables of numbers.

Give each small group of students a copy of the *Card Set D: Areas*, a large sheet of paper, and a glue stick.

Each of these cards shows an area.

I want you to match these area cards to the cards already on the table.

When you reach agreement, paste down your final arrangement onto the large sheet, creating a poster.

Next to each group write down why the areas show that different expressions are equivalent.

These posters will be displayed in the final class discussion.

As students match the cards, encourage them to explain and write down **why** particular pairs of cards go together.

Why does this area correspond to $n^2 + 12n + 36$?

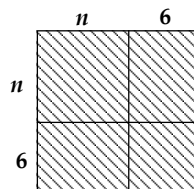

Show me where n^2 is in this diagram. Where is $12n$? Where is the 36 part of the diagram?

Now show me why it also shows $(n+6)^2$.

Where is the $n+6$?



Ask students to identify groups of expressions that are equivalent and explain their reasoning. For example, E1 is equivalent to E10, E8 is equivalent to E9, and E4 is equivalent to E5.

Whole-class discussion (15 minutes)

Hold a whole-class interactive discussion to review what has been learned over this lesson.

Ask each group of students to justify, using their poster, why two expressions are equivalent.

Then use mini-whiteboards and questioning to begin to generalize the learning.

Draw me an area that shows this expression: $3(x + 4)$

Write me a different expression that gives the same area.

Draw me an area that shows this expression: $(4y)^2$

Write me a different expression that gives the same area.

Draw me an area that shows this expression: $(z + 5)^2$

Write me a different expression that gives the same area.

Draw me an area that shows this expression: $\frac{w + 6}{2}$

Write me a different expression that gives the same area.

Review individual solutions to the assessment task (10 minutes)

Return students' work on the assessment task *Interpreting Expressions*, along with a fresh copy of the task sheet. If you chose to write a list of questions rather than write questions on individual papers, display your questions now.

Read through the solution you wrote [yesterday] and think about what you learned this lesson.

Write a new solution, bearing in mind what you've learned, to see if you can improve your work.

If you are running out of time you could postpone this activity until the next lesson, or set it for homework.

SOLUTIONS

This table is for convenience only: it is helpful **not** to refer to cards by these letters in class, but rather to the content of the cards.

Expressions	Words	Tables	Areas
E1	W4		A5
E2		T4	A3
E3	W7	T1	A1
E4	W1	T6	A2
E5	W5		A2
E6	W8	T8	A6
E7	W2	T2	A4
E8	W6	T5	A7
E9	W6		A7
E10		T7	A5
E11	W9	T3	A8
E12			
	W3		
	W10		

Interpreting Expressions

1. Write algebraic expressions for each of the following:

- a. Multiply n by 5 then add 4. _____
- b. Add 4 to n then multiply by 5. _____
- c. Add 4 to n then divide by 5. _____
- d. Multiply n by n then multiply by 3. _____
- e. Multiply n by 3 then square the result. _____

2. The equations below were created by students who were asked to write equivalent expressions on either side of the equals sign.

Imagine you are a teacher. Your job is to decide whether their work is right or wrong. If you see an equation that is false, then:

- a. Cross out the expression on the right and replace it with an expression that is equivalent to the one on the left.
- b. Explain what is wrong, using words or diagrams.

$$2(n + 3) = 2n + 3$$

$$\frac{10n - 5}{5} = 2n - 1$$

$$(5n)^2 = 5n^2$$

$$(n + 3)^2 = n^2 + 3^2 = n^2 + 9$$

Card Set A: *Expressions*

E1 $\frac{n+6}{2}$	E2 $3n^2$
E3 $2n+12$	E4 $2n+6$
E5 $2(n+3)$	E6 $\frac{n}{2}+6$
E7 $(3n)^2$	E8 $(n+6)^2$
E9 $n^2+12n+36$	E10 $3+\frac{n}{2}$
E11 n^2+6	E12 n^2+6^2
E13	E14

Card Set B: *Words*

W1 Multiply n by two, then add six.	W2 Multiply n by three, then square the answer.
W3 Add six to n then multiply by two.	W4 Add six to n then divide by two.
W5 Add three to n then multiply by two.	W6 Add six to n then square the answer.
W7 Multiply n by two then add twelve.	W8 Divide n by two then add six.
W9 Square n , then add six	W10 Square n , then multiply by nine
W11	W12
W13	W14

Card Set C: Tables

<p>T1</p> <table border="1"> <tbody> <tr> <td><i>n</i></td> <td>1</td> <td>2</td> <td>3</td> <td>4</td> </tr> <tr> <td><i>Ans</i></td> <td>14</td> <td>16</td> <td>18</td> <td>20</td> </tr> </tbody> </table>	<i>n</i>	1	2	3	4	<i>Ans</i>	14	16	18	20	<p>T2</p> <table border="1"> <tbody> <tr> <td><i>n</i></td> <td>1</td> <td>2</td> <td>3</td> <td>4</td> </tr> <tr> <td><i>Ans</i></td> <td></td> <td></td> <td>81</td> <td>144</td> </tr> </tbody> </table>	<i>n</i>	1	2	3	4	<i>Ans</i>			81	144
<i>n</i>	1	2	3	4																	
<i>Ans</i>	14	16	18	20																	
<i>n</i>	1	2	3	4																	
<i>Ans</i>			81	144																	
<p>T3</p> <table border="1"> <tbody> <tr> <td><i>n</i></td> <td>1</td> <td>2</td> <td>3</td> <td>4</td> </tr> <tr> <td><i>Ans</i></td> <td></td> <td>10</td> <td>15</td> <td>22</td> </tr> </tbody> </table>	<i>n</i>	1	2	3	4	<i>Ans</i>		10	15	22	<p>T4</p> <table border="1"> <tbody> <tr> <td><i>n</i></td> <td>1</td> <td>2</td> <td>3</td> <td>4</td> </tr> <tr> <td><i>Ans</i></td> <td>3</td> <td></td> <td>27</td> <td>48</td> </tr> </tbody> </table>	<i>n</i>	1	2	3	4	<i>Ans</i>	3		27	48
<i>n</i>	1	2	3	4																	
<i>Ans</i>		10	15	22																	
<i>n</i>	1	2	3	4																	
<i>Ans</i>	3		27	48																	
<p>T5</p> <table border="1"> <tbody> <tr> <td><i>n</i></td> <td>1</td> <td>2</td> <td>3</td> <td>4</td> </tr> <tr> <td><i>Ans</i></td> <td></td> <td></td> <td>81</td> <td>100</td> </tr> </tbody> </table>	<i>n</i>	1	2	3	4	<i>Ans</i>			81	100	<p>T6</p> <table border="1"> <tbody> <tr> <td><i>n</i></td> <td>1</td> <td>2</td> <td>3</td> <td>4</td> </tr> <tr> <td><i>Ans</i></td> <td></td> <td>10</td> <td>12</td> <td>14</td> </tr> </tbody> </table>	<i>n</i>	1	2	3	4	<i>Ans</i>		10	12	14
<i>n</i>	1	2	3	4																	
<i>Ans</i>			81	100																	
<i>n</i>	1	2	3	4																	
<i>Ans</i>		10	12	14																	
<p>T7</p> <table border="1"> <tbody> <tr> <td><i>n</i></td> <td>1</td> <td>2</td> <td>3</td> <td>4</td> </tr> <tr> <td><i>Ans</i></td> <td></td> <td>4</td> <td></td> <td>5</td> </tr> </tbody> </table>	<i>n</i>	1	2	3	4	<i>Ans</i>		4		5	<p>T8</p> <table border="1"> <tbody> <tr> <td><i>n</i></td> <td>1</td> <td>2</td> <td>3</td> <td>4</td> </tr> <tr> <td><i>Ans</i></td> <td>6.5</td> <td>7</td> <td>7.5</td> <td>8</td> </tr> </tbody> </table>	<i>n</i>	1	2	3	4	<i>Ans</i>	6.5	7	7.5	8
<i>n</i>	1	2	3	4																	
<i>Ans</i>		4		5																	
<i>n</i>	1	2	3	4																	
<i>Ans</i>	6.5	7	7.5	8																	

Card Set D: Areas

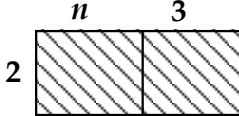
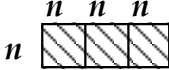
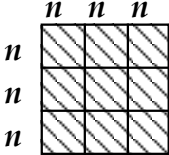
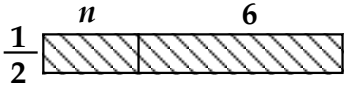
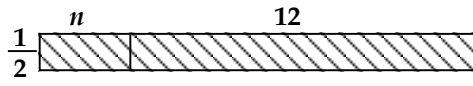
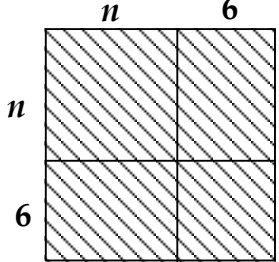
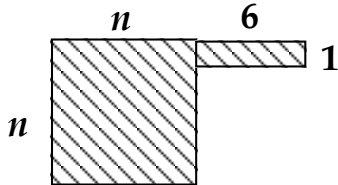
<p>A1</p> 	<p>A2</p> 
<p>A3</p> 	<p>A4</p> 
<p>A5</p> 	<p>A6</p> 
<p>A7</p> 	<p>A8</p> 

Matching Expressions and Words

$$4(n + 2)$$

Multiply n by two, then add four.

$$2(n + 4)$$

Add four to n , then multiply by two.

$$4n + 2$$

Add two to n , then multiply by four.

Mathematics Assessment Project
CLASSROOM CHALLENGES

This lesson was designed and developed by the
Shell Center Team
at the
University of Nottingham
Malcolm Swan, Nichola Clarke, Clare Dawson, Sheila Evans
with
Hugh Burkhardt, Rita Crust, Andy Noyes, and Daniel Pead

It was refined on the basis of reports from teams of observers led by
David Foster, Mary Bouck, and Diane Schaefer
based on their observation of trials in US classrooms
along with comments from teachers and other users.

This project was conceived and directed for
MARS: Mathematics Assessment Resource Service
by
Alan Schoenfeld, Hugh Burkhardt, Daniel Pead, and Malcolm Swan
and based at the University of California, Berkeley

We are grateful to the many teachers, in the UK and the US, who trialed earlier versions
of these materials in their classrooms, to their students, and to
Judith Mills, Carol Hill, and Alvaro Villanueva who contributed to the design.

This development would not have been possible without the support of
Bill & Melinda Gates Foundation
We are particularly grateful to
Carina Wong, Melissa Chabran, and Jamie McKee

© 2012 MARS, Shell Center, University of Nottingham
This material may be reproduced and distributed, without modification, for non-commercial purposes,
under the Creative Commons License detailed at <http://creativecommons.org/licenses/by-nc-nd/3.0/>
All other rights reserved.
Please contact map.info@mathshell.org if this license does not meet your needs.

Algebraic Expressions

Additional Problem Sets

Note for the Teacher: *The problem sets below are provided to you as supplemental material. You may choose to use these problems for extra practice, assessment, re-teach and/or enrichment opportunities.*

- Sandra has 6 grandchildren, and she gave each of them \$24.50. How much money did she give to her grandchildren altogether?
 - Nita bought some games for her grandchildren for \$42.50 each. If she spent a total of \$340, how many games did Nita buy?
 - Helen gave each of her 7 grandchildren an equal amount of money. If she gave a total of \$227.50, how much did each grandchild get?

<http://illustrativemathematics.org/illustrations/374>

- Sophia's dad paid \$43.25 for 12.5 gallons of gas. What is the cost of one gallon of gas?
- Hallie is in 6th grade and she can buy movie tickets for \$8.25. Hallie's father was in 6th grade in 1987 when movie tickets cost \$3.75.
 - When he turned 12, Hallie's father was given \$20.00 so he could take some friends to the movies. How many movie tickets could he buy with this money?
 - How many movie tickets can Hallie buy for \$20.00?
 - On Hallie's 12th birthday, her father said,
When I turned 12, my dad gave me \$20 so I could go with three of my friends to the movies and buy a large popcorn. I'm going to give you some money so you can take three of your friends to the movies and buy a large popcorn.
How much money do you think her father should give her?

<http://illustrativemathematics.org/illustrations/1299>

- Nina was finding multiples of 6. She said,
18 and 42 are both multiples of 6, and when I add them, I also get a multiple of 6:
 $18+42=60$.
Explain to Nina why adding two multiples of 6 will always result in another multiple of 6.

<http://illustrativemathematics.org/illustrations/257>

- On the same winter morning, the temperature is -28° in Anchorage, Alaska and 65° in Miami, Florida. How many degrees warmer was it in Miami than in Anchorage on that morning?

<http://illustrativemathematics.org/illustrations/277>

6. Denver, Colorado is called “The Mile High City” because its elevation is 5280 feet above sea level. Someone tells you that the elevation of Death Valley, California is -282 feet.
- Is Death Valley located above or below sea level? Explain.
 - How many feet higher is Denver than Death Valley?
 - What would your elevation be if you were standing near the ocean?

<http://illustrativemathematics.org/illustrations/278>

7. Ocean water freezes at about $-2\frac{1}{2}$ °C. Fresh water freezes at 0°C. Antifreeze, a liquid used to cool most car engines, freezes at -64 °C. Imagine that the temperature is exactly at the freezing point for ocean water. How many degrees must the temperature drop for the antifreeze to turn to ice?

<http://illustrativemathematics.org/illustrations/314>

8. Rosa ran $\frac{1}{3}$ of the way from her home to school. She ran $\frac{1}{4}$ mile. How far is it between her home and school?

<http://illustrativemathematics.org/illustrations/409>

9. You are stuck in a big traffic jam on the freeway and you are wondering how long it will take to get to the next exit, that is $1\frac{1}{2}$ miles away. You are timing your progress and find that you can travel $\frac{2}{3}$ of a mile in one hour. If you continue to make progress at this rate, how long will it be until you reach the exit? Solve the problem with a diagram and explain your answer.

<http://illustrativemathematics.org/illustrations/464>

10. It requires $\frac{1}{4}$ of a credit to play a video game for one minute.
- Emma has $\frac{7}{8}$ credits. Can she play for more or less than one minute? Explain how you know.
 - How long can Emma play the video game with her $\frac{7}{8}$ credits?

<http://illustrativemathematics.org/illustrations/267>

11. Three math classes at Sunview High School collected the most box tops for a school fundraiser, and so they won a \$600 prize to share among them. Mr. Aceves' class collected 3,760 box tops, Mrs. Baca's class collected 2,301, and Mr. Canyon's class collected 1,855. How should they divide the money so that each class gets the same fraction of the prize money as the fraction of the box tops that they collected?

<http://illustrativemathematics.org/illustrations/298>

12. After opening an ancient bottle you find on the beach, a Djinni appears. In payment for his freedom, he gives you a choice of either 50,000 gold coins or one magical gold coin. The magic coin will turn into two gold coins on the first day. The two coins will turn into four coins total at the end of two days. By the end of the third day there will be eight gold coins total. The Djinni explains that the magic coins will continue this pattern of doubling each day for one moon cycle, 28 days. Which prize do you choose?

When you have made your choice, answer these questions:

- The number of coins on the third day will be $2 \times 2 \times 2$. Can you write another expression using exponents for the number of coins there will be on the third day?
- Write an expression for the number of coins there will be on the 28th day. Is this more or less than a million coins?

<http://illustrativemathematics.org/illustrations/532>

13. Evaluate the following numerical expressions.

- $2(5+(3)(2)+4)$
- $2((5+3)(2+4))$
- $2(5+3(2+4))$

Can the parentheses in any of these expressions be removed without changing the value the expression?

<http://illustrativemathematics.org/illustrations/1136>

14. Some of the students at Kahlo High School like to ride their bikes to and from school. They always ride unless it rains. Let d be the distance in miles from a student's home to the school. Write two different expressions that represent how far a student travels by bike in a four-week period if there is one rainy day each week.

<http://illustrativemathematics.org/illustrations/540>

15. Which of the following expressions are equivalent? Why? If an expression has no match, write 2 equivalent expressions to match it.

- $2(x+4)$
- $8+2x$
- $2x+4$
- $3(x+4)-(4+x)$
- $x+4$

<http://illustrativemathematics.org/illustrations/542>

SREB Readiness Courses
Transitioning to college and careers

College Readiness Mathematics

Unit 1 . Algebraic Expressions
Student Manual
Version 3

Name



Unit 1 . Algebraic Expressions

Table of Contents

Lesson 1.....	3
Lesson 2.....	6
Lesson 3.....	8
Lesson 4.....	10
Lesson 5.....	14
Lesson 6.....	19

Task #1: Bucky the Badger

Restate the Bucky the Badger problem in your own words:

Construct a viable argument for the following:

About how many total push-ups do you think Bucky did during the game?

Write down a number that you know is too high.

Write down a number that you know is too low.

What further information would you need to know in order to determine the exact number of total push-ups Bucky did in the course of the game?

If you're Bucky, would you rather your team score their field goals at the start of the game or the end?

What are some numbers of pushups that Bucky will never do in any game?

Task #2: Reasoning about Multiplication and Division and Place Value

Use the fact that $13 \times 17 = 221$ to find the following:

a. 13×1.7

b. 130×17

c. 13×1700

d. 1.3×1.7

e. $2210 \div 13$

f. $22100 \div 17$

g. $221 \div 1.3$

(Source: Illustrative Mathematics)

Task #3: Felicia's Drive

As Felicia gets on the freeway to drive to her cousin's house, she notices that she is a little low on gas. There is a gas station at the exit she normally takes, and she wonders if she will have to get gas before then. She normally sets her cruise control at the speed limit of 70mph and the freeway portion of the drive takes about an hour and 15 minutes. Her car gets about 30 miles per gallon on the freeway, and gas costs \$3.50 per gallon. (Source: Illustrative Mathematics)

- a. Describe an estimate that Felicia might do in her head while driving to decide how many gallons of gas she needs to make it to the gas station at the other end.

- b. Assuming she makes it, how much does Felicia spend per mile on the freeway?

Numbers and Operations

Magic Math: Number Guess



Instructions

Original Number	

Numbers and Operations

Magic Math: Birthday Trick

Do you believe that I can figure out your birthday by using simple math?

Get a calculator and ask your classmate to try the following. Your classmate must press equal (or enter) between every step.

- a) Enter the month of his/her birth into the calculator. (Ex: enter 5 for May)
- b) Multiply that number by 7.
- c) Subtract 1 from that result.
- d) Multiply that result by 13.
- e) Add the day of birth. (Ex: For June 14th add 14)
- f) Add 3.
- g) Multiply by 11.
- h) Subtract the month of birth.
- i) Subtract the day of birth.
- j) Divide by 10.
- k) Add 11.
- l) Divide by 100.

Task #4: Miles to Kilometers

The students in Mr. Sanchez's class are converting distances measured in miles to kilometers. To estimate the number of kilometers, Abby takes the number of miles, doubles it, then subtracts 20% of the result. Renato first divides the number of miles by 5 and then multiplies the result by 8.

- a. Write an algebraic expression for each method.

- b. Use your answer to part (a) to decide if the two methods give the same answer.

(Source: Illustrative Mathematics)

Independent Practice:

School Lunches & Movie Tickets

Find the cost of school lunches (adult and student) for three different area schools. Then create a table of values. Also find the number of students and teachers at each school.

Write an expression based on the table for each of the following:

Schools	Student	Adult
A		
B		
C		

- A. Cost of feeding 30 students and 5 adults
- B. Cost of feeding 43 adults and 75 students
- C. Cost of feeding each of the school’s students and teachers.

Find movie tickets prices at five different cities around the country. Include adult, children, matinee and regular shows.

City	Adult matinee	Adult regular	Child matinee	Child regular
A				
B				
C				
D				
E				

- A. You have \$100. In which city can you take the most adults and children to the matinee, if for every two children there is an adult?

- B. What is the cost of four children and three adults for a matinee in each of the five cities?

- C. Which city has the best deal for a family of five to attend the movies? Decide whether it is a matinee or regular show.

Task 5: Swimming Pool

You want to build a square swimming pool in your backyard. Let s denote the length of each side of the swimming pool (measured in feet). You plan to surround the pool by square border tiles, each of which is 1 foot by 1 foot (see figure).

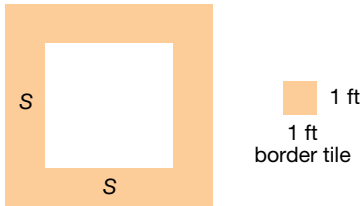

A teacher asks her students to find an expression for the number of tiles needed to surround such a square pool, and sees the following responses from her students:

$4(s+1)$

s^2

$4s+4$

$2s+2(s+2)$

$4s$

Is each mathematical model correct or incorrect? How do you know?

$4(s+1)$ _____

s^2 _____

$4s+4$ _____

$2s+2(s+2)$ _____

$4s$ _____

Task #6: Smartphones

Suppose p and q represent the price (in dollars) of a 64GB and a 32GB smartphone, respectively, where $p > q$. Interpret each of the expressions in terms of money and smartphones. Then, if possible, determine which of the expressions in each pair is larger.

$p+q$ and $2q$

$p+0.08p$ and $q+0.08q$

$600-p$ and $600-q$

Task #7: University Population

Let x and y denote the number male and female students, respectively, at a university. where $x < y$. If possible, determine which of the expressions in each pair is larger? Interpret each of the expressions in terms of populations.

$x+y$ and $2y$

$\frac{x}{x+y}$ and $\frac{y}{x+y}$

$\frac{x-y}{2}$ and $\frac{x}{x+y}$

Independent Practice

For each pair of expressions below, without substituting in specific values, determine which of the expressions in the given pairs is larger. Explain your reasoning in a sentence or two.

$$5+t^2 \text{ and } 3-t^2$$

$$\frac{15}{x^2+6} \text{ and } \frac{15}{x^2+7}$$

$$(s^2+2)(s^2+1) \text{ and } (s^2+4)(s^2+3)$$

$$\frac{8}{k^2+2} \text{ and } k^2+2$$

Task #8: Sidewalk Patterns

Sidewalk Patterns

In Prague some sidewalks are made of small square blocks of stone.

The blocks are in different shades to make patterns that are in various sizes.

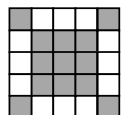

Pattern #1

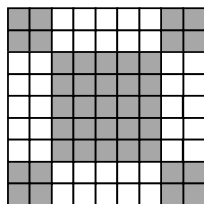

Pattern #2

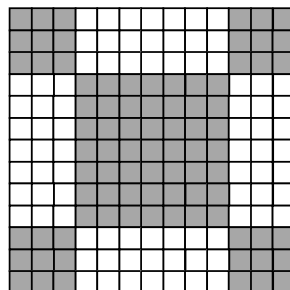

Pattern #3

Draw the next pattern in this series.

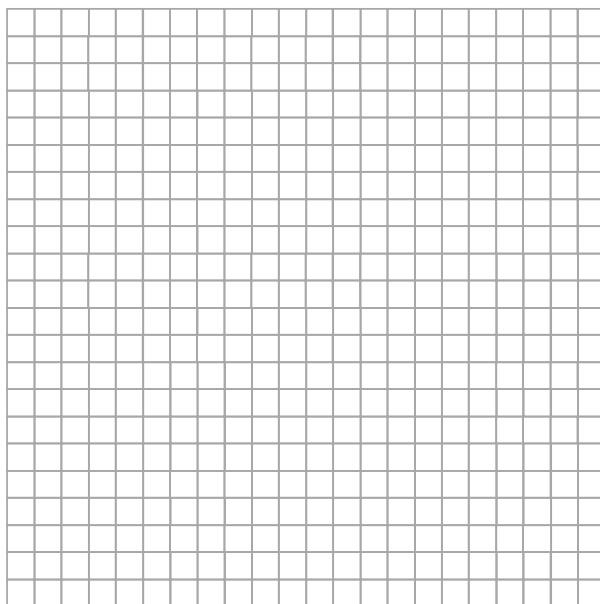

Pattern #4

1. Complete the table below

Pattern number, n	1	2	3	4
Number of white blocks	12	40		
Number of gray blocks	13			
Total number of blocks	25			

2. What do you notice about the number of white blocks and the number of gray blocks?

3. The total number of blocks can be found by squaring the number of blocks along one side of the pattern.

a. Fill in the blank spaces in this list.

$25 = 5^2$ $81 = \underline{\hspace{2cm}}$ $169 = \underline{\hspace{2cm}}$ $289 = 17^2$

b. How many blocks will pattern #5 need? _____

c. How many blocks will pattern # n need? _____

4. a. If you know the total number of blocks in a pattern you can work out the number of white blocks in it. Explain how you can do this.

b. Pattern # 6 has a total of 625 blocks.
How many white blocks are needed for pattern #6? _____
Show how you figured this out.

Task #9: Expression Pairs: Equivalent or Not?

$a+(3-b)$ and $(a+3)-b$

$2+\frac{k}{5}$ and $10+k$

$(a-b)^2$ and a^2-b^2

$3(z+w)$ and $3z+3w$

$-a+2$ and $-(a+2)$

$\frac{1}{x+y}$ and $\frac{1}{x} + \frac{1}{y}$

x^2+4x^2 and $5x^2$

$\sqrt{x^2+y^2}$ and $x+y$

$bc-cd$ and $c(b-d)$

$(2x)^2$ and $4x^2$

$2x+4$ and $x+2$

Task #10: Kitchen Floor Tiles

Fred has some colored kitchen floor tiles and wants to choose a pattern to make a border around white tiles. He generates patterns by starting with a row of four white tiles. He surrounds these four tiles with a border of colored tiles (Border 1). The design continues as shown below:

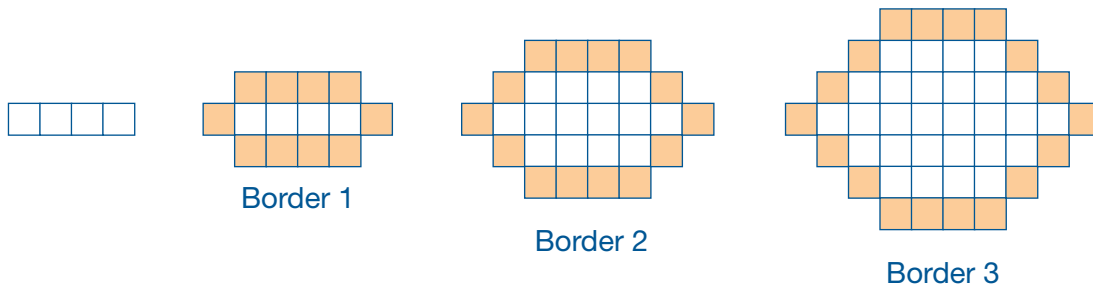

Fred writes the expression $4(b-1) + 10$ for the number of tiles in each border, where b is the border number, $b \geq 1$.

- Explain why Fred’s expression is correct.

- Emma wants to start with five tiles in a row. She reasons, “Fred started with four tiles and his expression was $4(b-1) + 10$. So if I start with five tiles, the expression will be $5(b-1) + 10$. Is Emma’s statement correct? Explain your reasoning.

- If Emma starts with a row of n tiles, what should the expression be?

Independent Practice

On the figure below, indicate intervals of length:

- $x+1$
- $3x+1$
- $3(x+1)$



What do your answers tell you about whether $3x+1$ and $3(x+1)$ are equivalent?

Task #11: Distributive Property Using Area

Distributive Property Using Area

NAME _____

Write the expression that represents the area of each rectangle.

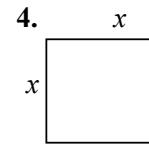
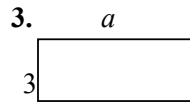
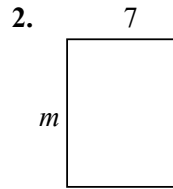
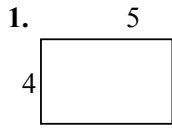

Find the area of each box in the pair.

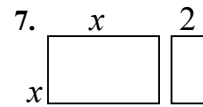
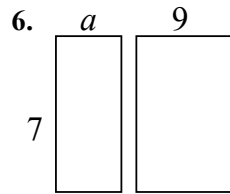
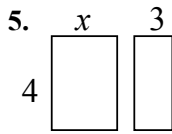

Write the expression that represents the total length of each segment.

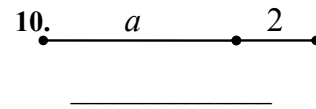
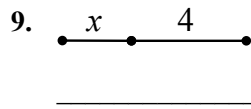
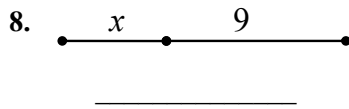

Write the area of each rectangle as the product of *length* \times *width* and also as a sum of the areas of each box.

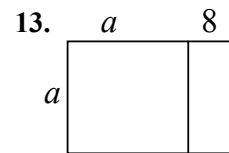
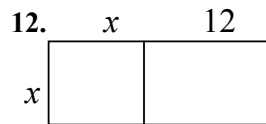
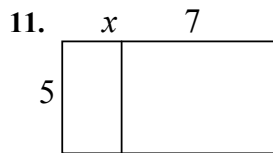

AREA AS PRODUCT	AREA AS SUM
$5(x+7)$	$5x+35$

AREA AS PRODUCT	AREA AS SUM

AREA AS PRODUCT	AREA AS SUM

This process of writing these products as a sum uses the **distributive property**.

Use the distributive property to re-write each expression as a sum. You may want to draw a rectangle on a separate page to follow the technique above.

- 14. $4(x+7) =$ _____
- 16. $-2(x+4) =$ _____
- 18. $a(a-1) =$ _____
- 20. $-4(a-4) =$ _____

- 15. $7(x-3) =$ _____
- 17. $x(x+9) =$ _____
- 19. $3m(m+2) =$ _____
- 21. $a(a-12) =$ _____

Task #12: Factoring a Common Factor Using Area

Factoring a Common Factor Using Area

NAME _____

Fill in the missing information for each: dimensions, area as product, and area as sum

<p>1.</p> <table border="1" style="margin-left: 40px; border-collapse: collapse;"> <tr> <td style="width: 50px; text-align: center;">x</td> <td style="width: 50px; text-align: center;">6</td> </tr> <tr> <td style="width: 20px; text-align: center;">2</td> <td style="width: 20px; text-align: center;">2</td> </tr> <tr> <td style="width: 50px; height: 40px; text-align: center;"><input type="text"/></td> <td style="width: 50px; height: 40px; text-align: center;"><input type="text"/></td> </tr> </table> <p>_____</p> <p>_____</p>	x	6	2	2	<input type="text"/>	<input type="text"/>	<p>2.</p> <table border="1" style="margin-left: 40px; border-collapse: collapse;"> <tr> <td style="width: 50px; text-align: center;"><input type="text"/></td> <td style="width: 50px; text-align: center;"><input type="text"/></td> </tr> <tr> <td style="width: 20px; text-align: center;">5</td> <td style="width: 20px; text-align: center;">5</td> </tr> <tr> <td style="width: 50px; height: 40px; text-align: center;">$5x$</td> <td style="width: 50px; height: 40px; text-align: center;">20</td> </tr> </table> <p>_____</p> <p>_____</p>	<input type="text"/>	<input type="text"/>	5	5	$5x$	20	<p>3.</p> <table border="1" style="margin-left: 40px; border-collapse: collapse;"> <tr> <td style="width: 50px; text-align: center;"><input type="text"/></td> <td style="width: 50px; text-align: center;">8</td> </tr> <tr> <td style="width: 20px; text-align: center;"><input type="text"/></td> <td style="width: 20px; text-align: center;">6</td> </tr> <tr> <td style="width: 50px; height: 40px; text-align: center;">$6x$</td> <td style="width: 50px; height: 40px; text-align: center;">48</td> </tr> </table> <p>_____</p> <p>_____</p>	<input type="text"/>	8	<input type="text"/>	6	$6x$	48	<p>4.</p> <table border="1" style="margin-left: 40px; border-collapse: collapse;"> <tr> <td style="width: 50px; text-align: center;">x</td> <td style="width: 50px; text-align: center;"><input type="text"/></td> </tr> <tr> <td style="width: 20px; text-align: center;"><input type="text"/></td> <td style="width: 20px; text-align: center;">10</td> </tr> <tr> <td style="width: 50px; height: 40px; text-align: center;">$10x$</td> <td style="width: 50px; height: 40px; text-align: center;">30</td> </tr> </table> <p>_____</p> <p>_____</p>	x	<input type="text"/>	<input type="text"/>	10	$10x$	30
x	6																										
2	2																										
<input type="text"/>	<input type="text"/>																										
<input type="text"/>	<input type="text"/>																										
5	5																										
$5x$	20																										
<input type="text"/>	8																										
<input type="text"/>	6																										
$6x$	48																										
x	<input type="text"/>																										
<input type="text"/>	10																										
$10x$	30																										

Fill in the missing dimensions from the expression given.

<p>5. $5x + 35 = 5(\text{_____})$</p> <table border="1" style="margin-left: 40px; border-collapse: collapse;"> <tr> <td style="width: 50px; text-align: center;"><input type="text"/></td> <td style="width: 50px; text-align: center;"><input type="text"/></td> </tr> <tr> <td style="width: 20px; text-align: center;"><input type="text"/></td> <td style="width: 20px; text-align: center;"><input type="text"/></td> </tr> <tr> <td style="width: 50px; height: 40px; text-align: center;"><input type="text"/></td> <td style="width: 50px; height: 40px; text-align: center;"><input type="text"/></td> </tr> </table>	<input type="text"/>	<input type="text"/>	<input type="text"/>	<input type="text"/>	<input type="text"/>	<input type="text"/>	<p>6. $2x + 12 = 2(\text{_____})$</p> <table border="1" style="margin-left: 40px; border-collapse: collapse;"> <tr> <td style="width: 50px; text-align: center;"><input type="text"/></td> <td style="width: 50px; text-align: center;"><input type="text"/></td> </tr> <tr> <td style="width: 20px; text-align: center;"><input type="text"/></td> <td style="width: 20px; text-align: center;"><input type="text"/></td> </tr> <tr> <td style="width: 50px; height: 40px; text-align: center;"><input type="text"/></td> <td style="width: 50px; height: 40px; text-align: center;"><input type="text"/></td> </tr> </table>	<input type="text"/>	<input type="text"/>	<input type="text"/>	<input type="text"/>	<input type="text"/>	<input type="text"/>	<p>7. $3x - 21 = \text{_____}(\text{_____})$</p> <table border="1" style="margin-left: 40px; border-collapse: collapse;"> <tr> <td style="width: 50px; text-align: center;"><input type="text"/></td> <td style="width: 50px; text-align: center;"><input type="text"/></td> </tr> <tr> <td style="width: 20px; text-align: center;"><input type="text"/></td> <td style="width: 20px; text-align: center;"><input type="text"/></td> </tr> <tr> <td style="width: 50px; height: 40px; text-align: center;"><input type="text"/></td> <td style="width: 50px; height: 40px; text-align: center;"><input type="text"/></td> </tr> </table>	<input type="text"/>	<input type="text"/>	<input type="text"/>	<input type="text"/>	<input type="text"/>	<input type="text"/>
<input type="text"/>	<input type="text"/>																			
<input type="text"/>	<input type="text"/>																			
<input type="text"/>	<input type="text"/>																			
<input type="text"/>	<input type="text"/>																			
<input type="text"/>	<input type="text"/>																			
<input type="text"/>	<input type="text"/>																			
<input type="text"/>	<input type="text"/>																			
<input type="text"/>	<input type="text"/>																			
<input type="text"/>	<input type="text"/>																			
<p>8. $7x - 21 = \text{_____}(\text{_____})$</p> <table border="1" style="margin-left: 40px; border-collapse: collapse;"> <tr> <td style="width: 50px; text-align: center;"><input type="text"/></td> <td style="width: 50px; text-align: center;"><input type="text"/></td> </tr> <tr> <td style="width: 20px; text-align: center;"><input type="text"/></td> <td style="width: 20px; text-align: center;"><input type="text"/></td> </tr> <tr> <td style="width: 50px; height: 40px; text-align: center;"><input type="text"/></td> <td style="width: 50px; height: 40px; text-align: center;"><input type="text"/></td> </tr> </table>	<input type="text"/>	<input type="text"/>	<input type="text"/>	<input type="text"/>	<input type="text"/>	<input type="text"/>	<p>9. $-3x - 15 = -3(\text{_____})$</p> <table border="1" style="margin-left: 40px; border-collapse: collapse;"> <tr> <td style="width: 50px; text-align: center;"><input type="text"/></td> <td style="width: 50px; text-align: center;"><input type="text"/></td> </tr> <tr> <td style="width: 20px; text-align: center;"><input type="text"/></td> <td style="width: 20px; text-align: center;"><input type="text"/></td> </tr> <tr> <td style="width: 50px; height: 40px; text-align: center;"><input type="text"/></td> <td style="width: 50px; height: 40px; text-align: center;"><input type="text"/></td> </tr> </table>	<input type="text"/>	<input type="text"/>	<input type="text"/>	<input type="text"/>	<input type="text"/>	<input type="text"/>	<p>10. $-5x + 45 = \text{_____}(\text{_____})$</p> <table border="1" style="margin-left: 40px; border-collapse: collapse;"> <tr> <td style="width: 50px; text-align: center;"><input type="text"/></td> <td style="width: 50px; text-align: center;"><input type="text"/></td> </tr> <tr> <td style="width: 20px; text-align: center;"><input type="text"/></td> <td style="width: 20px; text-align: center;"><input type="text"/></td> </tr> <tr> <td style="width: 50px; height: 40px; text-align: center;"><input type="text"/></td> <td style="width: 50px; height: 40px; text-align: center;"><input type="text"/></td> </tr> </table>	<input type="text"/>	<input type="text"/>	<input type="text"/>	<input type="text"/>	<input type="text"/>	<input type="text"/>
<input type="text"/>	<input type="text"/>																			
<input type="text"/>	<input type="text"/>																			
<input type="text"/>	<input type="text"/>																			
<input type="text"/>	<input type="text"/>																			
<input type="text"/>	<input type="text"/>																			
<input type="text"/>	<input type="text"/>																			
<input type="text"/>	<input type="text"/>																			
<input type="text"/>	<input type="text"/>																			
<input type="text"/>	<input type="text"/>																			

This process of writing a sum or difference as the product of factors is called **factoring**.

Factor these:

- | | |
|------------------------------|-------------------------------|
| 11. $4x - 16 = \text{_____}$ | 12. $-7x - 35 = \text{_____}$ |
| 13. $9x - 81 = \text{_____}$ | 14. $4x + 18 = \text{_____}$ |

Task #13: Distributive Property

Are the expressions equivalent? Sketch and simplify to prove. If the two expressions are not equal write the correct equivalence.

1. $3(x+3)$ and $3x+6$



2. $6(y+1)$ and $6y+6$

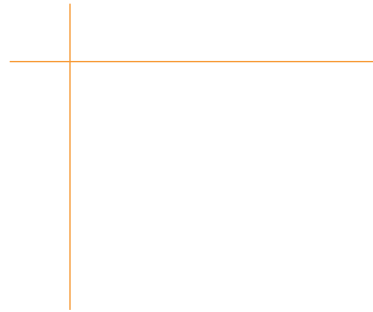

3. $x(x+4)$ and x^2+4

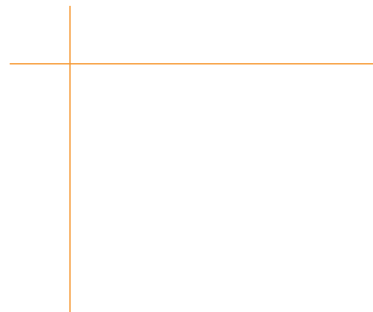

4. $y(x+2)$ and $xy+2y$



5. $x(x+y+2)$ and $x^2+xy+2x$



6. $2x(x+3)$ and $2x^2+6x$

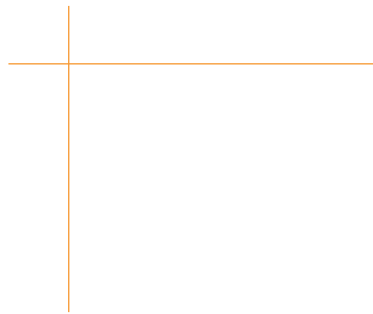

Distribute the following. Use a sketch or just distribute if you can.

1. $3(x+2)$

2. $4(y-1)$

3. $x(x+6)$

4. $x(y+4)$

5. $3x(x+y-1)$

Algebraic Expressions

Additional Problem Sets

Note for the Teacher: *The problem sets below are provided to you as supplemental material. You may choose to use these problems for extra practice, assessment, re-teach and/or enrichment opportunities.*

1.
 - a. Sandra has 6 grandchildren, and she gave each of them \$24.50. How much money did she give to her grandchildren altogether?
 - b. Nita bought some games for her grandchildren for \$42.50 each. If she spent a total of \$340, how many games did Nita buy?
 - c. Helen gave each of her 7 grandchildren an equal amount of money. If she gave a total of \$227.50, how much did each grandchild get?

2. Sophia's dad paid \$43.25 for 12.5 gallons of gas. What is the cost of one gallon of gas?

3. Hallie is in 6th grade and she can buy movie tickets for \$8.25. Hallie's father was in 6th grade in 1987 when movie tickets cost \$3.75.
 - a. When he turned 12, Hallie's father was given \$20.00 so he could take some friends to the movies. How many movie tickets could he buy with this money?
 - b. How many movie tickets can Hallie buy for \$20.00?
 - c. On Hallie's 12th birthday, her father said,
When I turned 12, my dad gave me \$20 so I could go with three of my friends to the movies and buy a large popcorn. I'm going to give you some money so you can take three of your friends to the movies and buy a large popcorn.
How much money do you think her father should give her?

4. Nina was finding multiples of 6. She said,
18 and 42 are both multiples of 6, and when I add them, I also get a multiple of 6:
 $18+42=60$.
Explain to Nina why adding two multiples of 6 will always result in another multiple of 6.

5. On the same winter morning, the temperature is -28° in Anchorage, Alaska and 65° in Miami, Florida. How many degrees warmer was it in Miami than in Anchorage on that morning?

6. Denver, Colorado is called “The Mile High City” because its elevation is 5280 feet above sea level. Someone tells you that the elevation of Death Valley, California is -282 feet.
 - a. Is Death Valley located above or below sea level? Explain.
 - b. How many feet higher is Denver than Death Valley?
 - c. What would your elevation be if you were standing near the ocean?

7. Ocean water freezes at about $-2\frac{1}{2}^{\circ}\text{C}$. Fresh water freezes at 0°C . Antifreeze, a liquid used to cool most car engines, freezes at -64°C . Imagine that the temperature is exactly at the freezing point for ocean water. How many degrees must the temperature drop for the antifreeze to turn to ice?

8. Rosa ran $\frac{1}{3}$ of the way from her home to school. She ran $\frac{1}{4}$ mile. How far is it between her home and school?

9. You are stuck in a big traffic jam on the freeway and you are wondering how long it will take to get to the next exit, that is $1\frac{1}{2}$ miles away. You are timing your progress and find that you can travel $\frac{2}{3}$ of a mile in one hour. If you continue to make progress at this rate, how long will it be until you reach the exit? Solve the problem with a diagram and explain your answer.

10. It requires $\frac{1}{4}$ of a credit to play a video game for one minute.
 - a. Emma has $\frac{7}{8}$ credits. Can she play for more or less than one minute? Explain how you know.
 - b. How long can Emma play the video game with her $\frac{7}{8}$ credits?

11. Three math classes at Sunview High School collected the most box tops for a school fundraiser, and so they won a \$600 prize to share among them. Mr. Aceves’ class collected 3,760 box tops, Mrs. Baca’s class collected 2,301, and Mr. Canyon’s class collected 1,855. How should they divide the money so that each class gets the same fraction of the prize money as the fraction of the box tops that they collected?

12. After opening an ancient bottle you find on the beach, a Djinni appears. In payment for his freedom, he gives you a choice of either 50,000 gold coins or one magical gold coin. The magic coin will turn into two gold coins on the first day. The two coins will turn into four coins total at the end of two days. By the end of the third day there will be eight gold coins total. The Djinni explains that the magic coins will continue this pattern of doubling each day for one moon cycle, 28 days. Which prize do you choose?

When you have made your choice, answer these questions:

- The number of coins on the third day will be $2 \times 2 \times 2$. Can you write another expression using exponents for the number of coins there will be on the third day?
- Write an expression for the number of coins there will be on the 28th day. Is this more or less than a million coins?

13. Evaluate the following numerical expressions.

- $2(5+(3)(2)+4)$
- $2((5+3)(2+4))$
- $2(5+3(2+4))$

Can the parentheses in any of these expressions be removed without changing the value the expression?

14. Some of the students at Kahlo High School like to ride their bikes to and from school. They always ride unless it rains. Let d be the distance in miles from a student's home to the school. Write two different expressions that represent how far a student travels by bike in a four-week period if there is one rainy day each week.

15. Which of the following expressions are equivalent? Why? If an expression has no match, write 2 equivalent expressions to match it.

- $2(x+4)$
- $8+2x$
- $2x+4$
- $3(x+4)-(4+x)$
- $x+4$

SREB

SREB Readiness Courses
Transitioning to college and careers

College Readiness Mathematics

Unit 2 . Equations
Version 3

Southern
Regional
Education
Board

592 Tenth Street, NW
Atlanta, GA 30318
(404) 875-9211

www.sreb.org

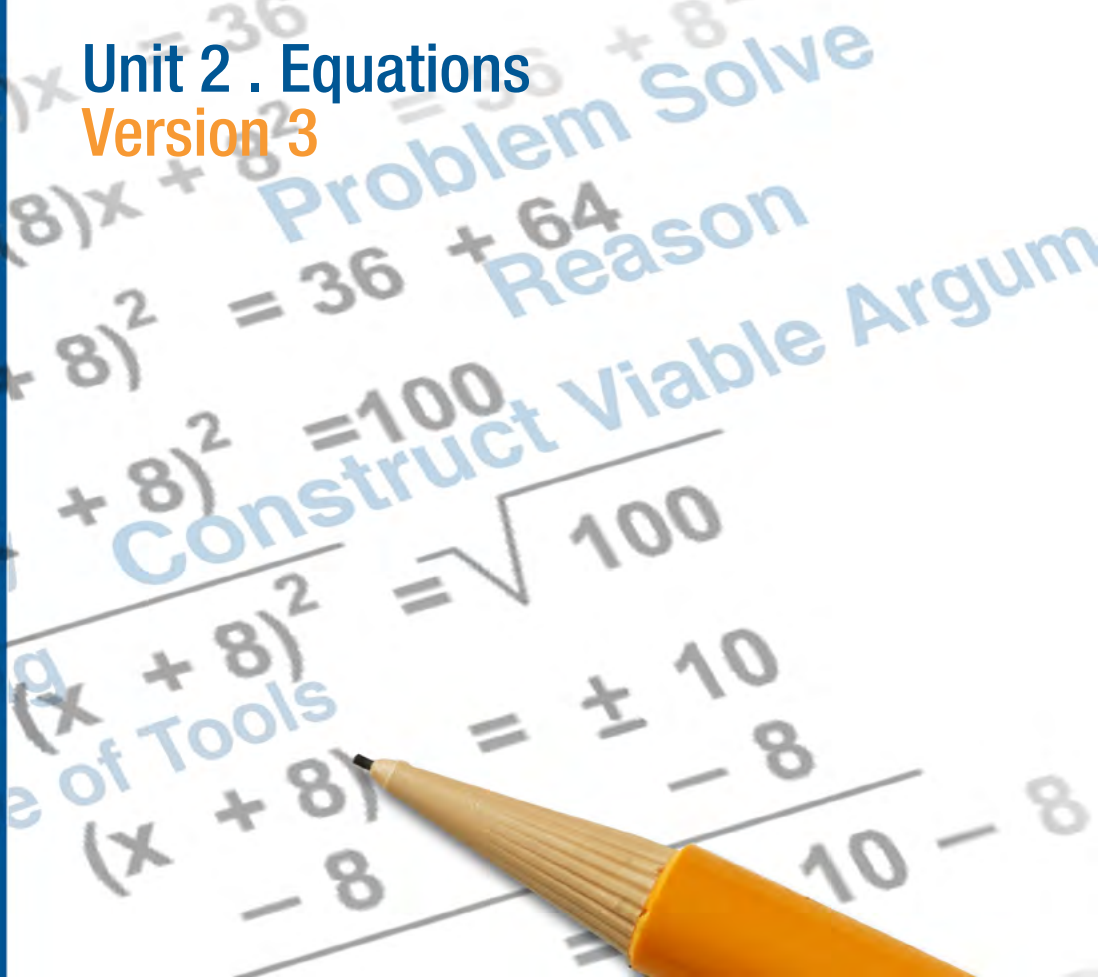

Unit 2 . Equations

Overview

Purpose

In this unit, students will revisit the concept and structure of equations and inequalities. The students will construct and evaluate problems that involve one or two steps while seeking the understanding of how and why equations and inequalities are used in their daily lives. Students are also asked to use the structure of word problems and equations to rewrite and solve equations in different forms revealing different relationships.

Essential Questions:

How might equations, expressions, inequalities and identities be similar? Different? Equivalent?

Why might certain operations be allowed to generate equivalent equations while others cannot?

How can you determine whether or not certain values are solutions to an equation or inequality?

How might you use the same reasoning as in solving equations to rearrange formulas to highlight a quantity of interest?

When can we infer practical meaning from the structure of the equation or inequality being used to model a real-world situation?

How might you use mathematical, practical and/or contextual reasoning when solving equations and inequalities?

Georgia Standards of Excellence:

Expressions and Equations

Analyze and solve linear equations and pairs of simultaneous linear equations.

- MGSE8.EE.7: Solve linear equations in one variable.

Seeing Structure in Equations

Interpret the structure of expressions.

- A.MGSE9-12.A.SSE.1: Interpret expressions that represent a quantity in terms of its context.

Write expressions in equivalent forms to solve problems.

- MGSE9-12.A.SSE.3: Choose and produce an equivalent form of an expression to reveal and explain properties of the quantity represented by the expression

Creating Equations

Create equations that describe numbers or relationships.

- MGSE9-12.A.CED.1: Create equations and inequalities in one variable and use them to solve problems. Include equations arising from linear, quadratic, simple rational, and exponential functions (integer inputs only).
- MGSE9-12.A.CED.2: Create linear, quadratic, and exponential equations in two or more variables to represent relationships between quantities; graph equations on coordinate axes with labels and scales. (The phrase “in two or more variables” refers to formulas like the compound interest formula, in which $A = P(1 + r/n)^{nt}$ has multiple variables.)
- MGSE9-12.A.CED.3: Represent constraints by equations or inequalities, and by systems of equations and/or inequalities, and interpret data points as possible (i.e. a solution) or not possible (i.e. a non-solution) under the established constraints.
- MGSE9-12.A.CED.4: Rearrange formulas to highlight a quantity of interest using the same reasoning as in solving equations. Examples: Rearrange Ohm’s law $V = IR$ to highlight resistance R ; Rearrange area of a circle formula $A = \pi r^2$ to highlight the radius, r .

Reasoning with Equations and Inequalities

Understand solving equations as a process of reasoning and explain the reasoning.

- MGSE9-12.A.REI.1: Using algebraic properties and the properties of real numbers, justify the steps of a simple, one-solution equation. Students should justify their own steps, or if given two or more steps of an equation, explain the progression from one step to the next using properties
- MGSE9-12.A.REI.2: Solve simple rational and radical equations in one variable, and give examples showing how extraneous solutions may arise.

Solve equations and inequalities in one variable.

- MGSE9-12.A.REI.3: Solve linear equations and inequalities in one variable including equations with coefficients represented by letters. For example, given $ax + 3 = 7$, solve for x .

Prior Scaffolding Knowledge / Skills:

- Students should be able to apply the properties of operations to generate equivalent expressions.
- Students should be able to identify and justify when two expressions are equivalent.
- Students should be able to construct and solve simple equations and inequalities.
- Students should understand the difference between an equation and inequality and how the solution set(s) differ.
- Students should be able to solve real-life and mathematical problems using numerical and algebraic expressions and equations.
- Students should be able to analyze relationships between variables using graphs and tables and relate these to the equation(s).

Lesson Progression Overview:

Lesson Big Idea	Lesson Details	Georgia Standards of Excellence	Standards for Mathematical Practice
Lesson 1: Constructing Expressions and Equations	Students will work from contextualized to decontextualized situations as well as vice versa. Students will be asked to construct and solve equations from verbal description. They will be given equations and asked to construct an accompanying verbal description with a solution.	MGSE8.EE.7 MGSE9-12.A.SSE.1 MGSE9-12.A.CED.1 MGSE9-12.A.REI.1	SMP 2 SMP 3 SMP 7
Lesson 2: The Structure of Equivalent Expressions and Equations	Students will study the structure of equations to determine if solutions exist. Additionally, students will examine expressions and equations to find pairs that are equivalent.	MGSE9-12.A.SSE.3 MGSE9-12.A.REI.1 MGSE9-12.A.REI.2	SMP 1 SMP 3 SMP 7
Lesson 3: Formative Assessment Lesson: Sorting Equations and Identities	Students will complete the Formative Assessment Lesson Sorting Equations and Identities. This lesson will assess students' understanding of equations and identities and will provoke discussion on common misconceptions in algebra.	MGSE9-12.A.SSE.3 MGSE9-12.A.REI.1 MGSE9-12.A.REI.2	SMP 3 SMP 7
Lesson 4: Restructuring Equations	In this lesson, students will work to rearrange equations in order to solve for a desired variable.	MGSE9-12.A.CED.1 MGSE9-12.A.CED.4 MGSE9-12.A.REI.1 MGSE9-12.A.REI.2 MGSE9-12.A.REI.3	SMP 2 SMP 3 SMP 7
Lesson 5: Inequalities	Students will explore the connection between equality and inequality. The behavior of inequalities in the negative number system is explored as well.	MGSE9-12.A.SSE.3 MGSE9-12.A.CED.1 MGSE9-12.A.CED.2 MGSE9-12.A.REI.1 MGSE9-12.A.REI.2 MGSE9-12.A.REI.3	SMP 1 SMP 2 SMP 7

Equations

Lesson 1 of 5

Constructing Expressions and Equations

Description:

Students will work from contextualized to decontextualized situations and vice versa. Students will be asked to construct and solve equations from verbal description. They will also be given equations and asked to construct an accompanying verbal description with a solution.

Georgia Standards of Excellence Addressed:

- MGSE8.EE.7: Solve linear equations in one variable.
- MGSE9-12.A.SSE.1: Interpret expressions that represent a quantity in terms of its context.
- MGSE9-12.A.CED.1: Create equations and inequalities in one variable and use them to solve problems. Include equations arising from linear, quadratic, simple rational, and exponential functions (integer inputs only).
- MGSE9-12.A.REI.1: Using algebraic properties and the properties of real numbers, justify the steps of a simple, one-solution equation. Students should justify their own steps, or if given two or more steps of an equation, explain the progression from one step to the next using properties.

Standard(s) for Mathematical Practice Emphasized:

- SMP 2: Reason abstractly and quantitatively.
- SMP 3: Construct viable arguments and critique the reasoning of others.
- SMP 7: Look for and make use of structure.

Sequence of Instruction

Activities Checklist

Engage



Entry Event: Begin with posing the following problem:

INCLUDED IN THE STUDENT MANUAL

Task #1: New Shoes

You want to buy a new pair of shoes. While looking around at different shoes and styles online, you see a coupon for \$10 off a pair of shoes at a local retailer in town. When you arrive at the store, you see they have sale, 15% off any pair of shoes in stock, but you are not allowed to apply any additional discounts. You do the math to decide whether the coupon or the 15% discount will save you the most money, and you find out the discounted price is the same no matter whether you use the coupon or receive 15% off from the sale. How much did the pair of shoes cost?

Without further prompting, ask students to work in pairs or threes to reason abstractly and quantitatively and solve the problem. While students are working, make note of the variety of approaches and sequence presentations accordingly. Start with a more concrete approach (perhaps a guess and check method) and structure presentations towards a more abstract (equation) approach.

Possible solutions:

Create a table of values such as:

Regular Price	\$40	\$60	\$80
Coupon Price	\$30	\$50	\$70
Sale Price	\$34	\$51	\$58

So, the shoes cost about \$60.

Let p be full price of the shoes in dollars. Then we want to find when $p - 10 = p - 0.15p$.

We receive \$10 off from the coupon no matter how much the original price is.

We receive $0.15p$ off from the sale. For what original price p is $0.15p = 10$?

Dividing both sides by 0.15 gives us $p = \$66.67$.

Use the following questions to elicit discussion during the student presentations:

- It is important at this point to emphasize the importance of being precise when defining an unknown variable such as p . What price does p represent? Original, after using coupon, or the after sale price? What are the units?
- If students do find an approximate solution using a table (or maybe even graphs), discuss the benefit that setting up an equation using an unknown variable allows us to find an exact solution.
- If one groups shares the equation $p - 10 = p - 0.15p$ and another shares $0.15p = 10$, ask if the equations are equivalent? Why? How could you prove? How does the structure of the equation tie back to the original information given? Which equation matches the problem better? Why? Justify your choice.

Explore



In this activity students are going to first generate a stack of playing cards in their groups then play a matching game with another group's set of cards.

Give each group of students a set of six equations. Four sets of six equations are provided here; if additional equations are needed either construct similar sets or let groups have the same sets of equations to begin with. On six separate index cards, have each group write a "story" problem corresponding with each equation in their set. This activity focuses on students contextualizing a decontextualized situation. Encourage students to be creative and draw upon previous situations in prior mathematics classes to construct their story problems. On six more index cards have students write a decontextualized answer in $x =$ form. Work should not be shown on the card, rather, work should be recorded elsewhere as cards will be traded among groups.

For example, if students had an equation of $4(x + 2) = 48$, a corresponding story problem could be "The length of a square is increased by 2 on each side. The resulting perimeter is 48. What is the original length of the square?"

For this example:

Card one: " $4(x + 2) = 48$ "

Card two: "The length of a square is increased by 2 on each side. The resulting perimeter is 48. What is the original length of the square?"

Card three: " $x = 10$ "

Equations

Equation Cards Set One

$$3(x - 2) = 27$$

$$5x + 15 = 75$$

$$1.075x = 15.95$$

$$2(x + 1) + 2(x + 4) = 50$$

$$7x - 14 = 56$$

$$9x + 2x + 10 = 131$$

Equations

Equation Cards Set Two

$$4(x - 1) = 28$$

$$2x + 14 = 64$$

$$1.075x = 29.95$$

$$2(x + 1) + 2(x - 3) = 60$$

$$8x - 16 = 64$$

$$10x + 3x - 12 = 144$$

Equations

Equation Cards Set Three

$$5(x - 1) = 30$$

$$4x + 16 = 64$$

$$1.065x = 14.93$$

$$2(x - 1) + 2(x + 3) = 70$$

$$9x - 18 = 73$$

$$12x + 2x - 11 = 157$$

Equations

Equation Cards Set Four

$$6(x + 1) = 36$$

$$3x - 15 = 33$$

$$1.065x = 27.98$$

$$2(x - 1) + 2(x + 4) = 72$$

$$6x - 24 = 60$$

$$14x - 2x + 10 = 118$$

Explanation



Have groups shuffle their cards and exchange all of their cards with another group. (There should be 18 cards total in a stack.) If the same sets were used, be mindful of making sure groups are exposed to different equations for solving purposes.

In their groups, students should match equations, words and the answers of their peers work. This yields an opportunity for students to critique the reasoning of others by making sure the sets are correct and the context makes sense. Students should be given the opportunity to provide feedback on the context and answers to the groups who constructed the deck of cards. If time allows, let the original groups fix their cards based off of feedback given by peers.

Spend a few minutes discussing some of the matches. The following questions could be used as class discourse prompts:

- What was your strategy in deciding how to match?
- Did a group member change your mind? If so, what made you think of the situation differently?
- Did your group provide feedback to another group?
- What was challenging about this process?
- Is it easier to take a contextualized situation and decontextualized it, or a decontextualized situation and make it contextualized?
- What does decontextualized and contextualized mean? Why is this helpful in mathematics?
- Could some of the equations be written in a different way? How so?

Practice Together in Small Groups or Individually



If students are reasonably proficient solving equations of the general form $P(x+Q) = K$ or $Ax+B=C$, then they can move on to working additional problems.

Ask the groups to work on the problems below, carefully explaining all of their steps in their solutions. Have some groups start with question one, then go to two and three. Have others start with two, then go to three and one. Have the rest start with question three, then go to one and two, so at least one group has solved one of the questions below. Instruct students to focus on writing the equation using the structure of the words and the corresponding structure of the word problems to solve these problems.

INCLUDED IN THE STUDENT MANUAL

Task #2: Equation Problems

1. Three girls downloaded a total of 36 songs on their iPods. Jane downloaded twice as many as Inez and since Tracy wanted to have the most, she downloaded one more than Jane did. How many songs did each girl download?
2. A checking account is set up with an initial balance of \$4,800, and \$300 is removed from the account each month for rent (no other transactions occur on the account). How many months will it take for the account balance to reach \$1,500?

3. Peyton is three years younger than Justin. Matt is four times as old as Peyton. If you add together the ages of Justin, Peyton and Matt, the total comes to 39 years. How old are Justin, Peyton, and Matt?

Answers:

1. Tracy downloaded 15 songs; Jane 14 songs; and Inez 7 songs.
2. 11 months.
3. Peyton is six; Justin is nine; and Matt is 24.

Evaluate Understanding



For each problem, pick one group to present their solution to the class. Encourage students to ask questions as their peers present their work. Ask if other groups obtained the same answer in a different manner or perhaps a different equation set up. Have students share as many approaches as possible highlighting the structure used. Discuss the different practical meanings of the set of the equations and why one method may be preferable to another.

Closing Activity



INCLUDED IN THE STUDENT MANUAL

Task #3: Gasoline Cost

You have \$40 to spend on n gallons of gas that costs \$3.25 per gallon. Determine whether each of the following is an expression or an equation. Using the structure, give an interpretation of the practical meaning of each.

1. $3.25n$
2. $3.25n = 26$
3. $40 - 3.25n$
4. $40 - 3.25n = 1.00$

Answers:

1. This is an expression that represents how much it will cost to buy n gallons of gas.
2. This is an equation whose solution represents the number of gallons you can buy for \$26.
3. This is an expression that represents the amount of money you will have left after buying n gallons of gas.
4. This is an equation that represents the amount of gas you bought if you received \$1 back in change.

The point of this closing activity is to emphasize the difference between expressions and equations. The two are often confused. Although they look very similar, they represent very different things. Equations must have equal signs. During the closing conversation, make sure to bring attention to the structure of each expression or equation to help better understanding its practical meaning.

Homework/Independent Outside of Class Work:

Ask students to work on the following questions before the next class.

INCLUDED IN THE STUDENT MANUAL

Task #4: Equations and Solutions

For each of the equations below, determine whether the given value is a solution or not.

1. $x + 2 = x^2 + 4$ at $x = 2$
2. $p + 2 = p^2 - 4$ at $p = -2$
3. $\frac{a - 5}{a + 5} = 1$ at $a = 0$
4. $\frac{5 - a}{5 + a} = -1$ at $a = 0$
5. $3(x - 8) = 3x - 8$ at $x = 0$
6. Which, out of the numbers 0, 1, -1, 2, -2, is/are solution(s) to the equation $4x^2 - 4x - 5 = 2x(x+3) - 1$?

Answers:

1. Not a solution.
2. $p = -2$ is a solution to this set.
3. Not a solution.
4. Not a solution.
5. Not a solution.
6. None are solutions.

Resources/Instructional Materials Needed:

- index cards

Notes:

Equations

Lesson 2 of 5

The Structure of Equivalent Expressions and Equations

Description:

Students will study the structure of equations to determine if solutions exist. Additionally, students will examine expressions and equations to find pairs that are equivalent.

Georgia Standards of Excellence Addressed:

- MGSE9-12.A.SSE.3: Choose and produce an equivalent form of an expression to reveal and explain properties of the quantity represented by the expression.
- MGSE9-12.A.REI.1: Using algebraic properties and the properties of real numbers, justify the steps of a simple, one-solution equation. Students should justify their own steps, or if given two or more steps of an equation, explain the progression from one step to the next using properties.
- MGSE9-12.A.REI.2: Solve simple rational and radical equations in one variable, and give examples showing how extraneous solutions may arise.

Standard(s) for Mathematical Practice Emphasized:

- SMP 1: Make sense of problems and persevere in solving them.
- SMP 3: Construct viable arguments and critique the reasoning of others.
- SMP 7: Look for and make use of structure.

Sequence of
Instruction

Activities Checklist

Engage



Put the following equations on the board:

1. $3x+5 = 11$

2. $x^2+1 = 10$

3. $1 = 9+x^2$

4. $3x-5 = 3x+6$

5. $1 = \frac{x+4}{3+x}$

6. $\frac{x-1}{2x-2} = 1$

Ask students, WITHOUT SOLVING, “How can you tell whether or not a solution exists for each equation?” Stress that they should not try to solve the equation, rather use the **structure** of the equation to determine whether a solution is possible or not. Students must be able to clearly support their reasoning.

Engage students in a whole-group discussion to summarize this activity. Focus on what it means for an equation to have a solution (you may refer back to the previous night’s homework). A value that makes both expressions on each side of the equation equal is called a **solution**. An equation may have one solution, no solution, two solutions, three solutions, etc., or even an infinite number of solutions.

Possible solutions:

1. Yes. If you add six to five you get 11, and there exists a value of x such that $3x = 6$.
2. Yes. Adding nine to one gives you 10, and there exists a value of x such that $x^2 = 9$.
3. No. For any value of x , x^2 will be greater than or equal to zero. If we add a non-negative number to nine, it is impossible to end up with one. (In the event that students remember working with complex solutions, praise them for recognizing the possibility of non-real solutions but explain that the focus of this lesson is on real solutions.)
4. No. No matter what x is, $3x$ is the same on both sides. Thus the number $3x$ minus 5 cannot be the same as the number $3x$ plus 6.
5. No. A fraction is equal to one when the numerator and denominator are equal to each other (and not zero); $x+4$ and $x+3$ can never be equal to each other no matter the value of x .
6. No. A fraction is equal to one when the numerator and denominator are equal to each other (and not zero). Notice that $2x-2 = 2(x-1)$. This means that the denominator is always twice the value of the numerator no matter the value of x . Therefore the fraction equals $\frac{1}{2}$ for all values of x except $x = 1$ (where the fraction will be undefined).

Explore



Illustrative Mathematics task **Same Solutions?**

INCLUDED IN THE STUDENT MANUAL

Task #5: Same Solutions?

Which of the following equations have the same solution? Give reasons for your answer that do not depend on solving the equations.

- I. $x + 3 = 5x - 4$
- II. $x - 3 = 5x + 4$
- III. $2x + 8 = 5x - 3$
- IV. $10x + 6 = 2x - 8$
- V. $10x - 8 = 2x + 6$
- VI. $0.3 + \frac{x}{10} = \frac{1}{2}x - 0.4$

(<http://www.illustrativemathematics.org/illustrations/613>)

Students should work in groups of three to match pairs of equivalent equations. Be sure to clearly instruct students to match equivalent equations and provide reasoning that does not depend on finding solutions. This task gives students a chance to exercise MP 3 by not only explaining their own reasoning to one another, but by also respectfully critiquing the reasoning of others. Students should be encouraged throughout the task to ask questions of their peers.

Ask students to write their answers on a large piece of chart paper. One student from each group should go to another group and compare answers. If they have different answers, have the remaining members explain their reasoning in how they determined their answers. Have students return to original groups and adjust answers if they believe it is necessary. If students decide to change answers, the returning student should explain why their original reasoning was wrong, and what the correct explanation for the answer is. When all groups are finished, have them post their solutions on the board.

Commentary for the Teacher:

The purpose of this task is to provide an opportunity for students to reason about equivalence of equations. The instruction to give reasons that do not depend on solving the equation is intended to focus attention on the transformation of equations as a deductive step.

Note that although it is possible to show that two equations are equivalent without solving them, it is more difficult to give reasons why they are not equivalent, even though they do not appear to be. Thus, in the end, confirmation of the solution is achieved by solving the equations.

Possible Solutions:

Equation V is Equation I multiplied by two, and with the left side written on the right.

Equation VI is Equation I divided by 10 with the two terms on the left written in the opposite order. So Equations I, V, and VI all have the same solutions.

Equation II has the signs of the constants changed from Equation I, so it probably does not have the same solution.

Equation III has two of the terms in Equation I, the x and -4 , multiplied by two, while the other two do not. It does not have the same solutions as equations I or II.

Equation IV is Equation II multiplied by two, with the constant terms moved to the opposite side of the equation. Equations II and IV have the same solutions.

Confirmation: The solutions to the equations are:

Equation	I	II	III	IV	V	VI
Solution	$\frac{7}{4}$	$-\frac{7}{4}$	$\frac{11}{3}$	$-\frac{7}{4}$	$\frac{7}{4}$	$\frac{7}{4}$

Explanation



Have groups share their solutions and reasoning behind how they determined their answers.

Students can support reasoning by discussing the operation(s) that have been performed to one equation in order to obtain the matching equation. Thus, it is

possible to determine whether two equations are equivalent without finding and comparing solutions. Note that it is not easy to show two equations are not equivalent without solving each and showing they have different solutions.

Have students verify their matches are correct by showing the equations have the same solution(s). *Be sure it is clear that we consider two equations equivalent if they have exactly the same solution(s).*

Practice Together / in Small Groups / Individually



Ask students to work individually on the following questions.

INCLUDED IN THE STUDENT MANUAL

Task #6: Equivalent or Not?

For each pair of equations, determine whether the second equation is the result of a valid operation on the first. If so, what is the operation?

1. $7+5x = 3-2x$ and $7+7x = 3$
2. $3(x-4) = 15$ and $x-4 = 15$
3. $x^2 = 6x$ and $x = 6$
4. $\frac{1}{(x-5)} = 10$ and $1 = 10(x-5)$

Answers:

1. add $2x$ to both sides
2. not equivalent
3. not equivalent, this will be confusing to some
4. multiply both sides by $x-5$

It is important that students understand that as long as you do the same (allowable) operations to both sides of an equation, you end up with an equivalent equation (thus the solution(s) do not change). Questions three and four will probably be confusing to students; however question three involves a very common mistake. Not EVERY operation leads to an equivalent expression. If, for example, you divide both sides of an equation by an expression that can be zero, you may lose some solutions. In question three, the first equation has solutions $x=0$ and $x=6$. The second equation has only one solution at $x=6$. When we divided both sides by the expression x , we lost the possible solution $x=0$. Question four is different however. We may likewise get into trouble when multiplying both sides by an expression that might be 0; however, in this case we know $x-5$ cannot be zero since $\frac{1}{(x-5)}$ is equal to 10. Thus, it is okay in this case that we multiply both sides by the non-zero expression $x - 5$. Students should again be encouraged to look at the structure of the equations to determine if the operations are valid (MP 7). Students may need further examples and clarification on this issue.

Evaluate Understanding



Pose the following questions to students. They should be prepared to fully explain their answers during the closing conversation.

1. Are equations $(3x+9)=6$ and $x+3=2$ equivalent?
2. Are expressions $3x+9$ and $x+3$ equivalent?
3. Are equations $\frac{x}{(x-2)} = 4$ and $x=4(x-2)$ equivalent?
4. Are expressions $\frac{x}{(x-2)}$ and x equivalent?

Solutions:

1. Yes. Both sides of the first equation can be divided by three in order to yield the second equation.
2. No. The first equation is three times the second.
3. Yes. The second equation is simply the first equation after multiplying both sides by $(x-2)$.
4. No; x cannot be equivalent to itself divided by a value not equal to x .

Closing Activity



This closing, whole-group discussion should be centered on the differences between expressions and equations. Although they may look very similar, equations and expressions behave very differently.

Students should share their responses to the four questions above. If there are still any lingering misconceptions, take time to try and clear up these problems. One possible misconception could be with the fourth problem. Students often do not want “to deal with fractions” and they recall they can multiply by $x - 2$ in order to “get rid of the fraction”. This only applies when trying to solve an EQUATION in which you are allowed to apply this operation to both sides. When simplifying an expression, we are not allowed to multiply/divide the expression by any value (other than one) or add/subtract any value (other than zero). Therefore, we must handle working with expressions and equations differently.

Homework/Independent Outside of Class Work:

INCLUDED IN THE STUDENT MANUAL

Task #7: Study Questions

You and a friend are getting ready to study for an assessment on expressions and equations. Knowing that your friend is still getting expressions and equations mixed up and doesn't always know how to tell if two expressions or two equations are equivalent, your job is to create a set of problems (and solutions) to help your friend study. Create a minimum of six problems that will address your friend's misconceptions and include the solutions for her/him to study. Make sure your reasoning is clearly articulated in the solutions.

Equations

Lesson 3 of 5

Formative Assessment Lesson: Sorting Equations and Identities

Description:

Students will complete the Formative Assessment Lesson: Sorting Equations and Identities. This lesson will assess students' understanding of equations and identities and will provoke discussion on common misconceptions in algebra.

Georgia Standards of Excellence Addressed:

- MGSE9-12.A.SSE.3: Choose and produce an equivalent form of an expression to reveal and explain properties of the quantity represented by the expression.
- MGSE9-12.A.REI.1: Using algebraic properties and the properties of real numbers, justify the steps of a simple, one-solution equation. Students should justify their own steps, or if given two or more steps of an equation, explain the progression from one step to the next using properties.
- MGSE9-12.A.REI.2: Solve simple rational and radical equations in one variable, and give examples showing how extraneous solutions may arise.

Standard(s) for Mathematical Practice Emphasized:

- SMP 3: Construct viable arguments and critique the reasoning of others.
- SMP 7: Look for and make use of structure.

The following *Formative Assessment Lesson* is a classroom-ready lesson included to help teachers assess and improve students' understanding of mathematical concepts and skills and their ability to use the mathematical process readiness indicators critical for college readiness.

Research has shown that formative assessment, as embodied in the following lesson, is a powerful way to improve student learning and performance. This approach first allows students to demonstrate their prior understandings and abilities in employing the mathematical processes, and then resolve their own difficulties and misconceptions through structured discussion. This results in more secure long-term learning, reducing the need for re-teaching that otherwise takes so much classroom time.

Many often ask, why don't students just remember the procedures they have been taught and practiced? The fact is, that approach works fine in the short term but, as every teacher knows, if procedural knowledge is not underpinned by conceptual understanding, students will quickly forget "how to do it."

Read more about the *Formative Assessment Lesson* rationale, structure, and philosophy using the *Brief Guide for Teachers and Administrators* that can be found at <http://map.mathshell.org/materials/index.php>.

CONCEPT DEVELOPMENT

Mathematics Assessment Project
CLASSROOM CHALLENGES
A Formative Assessment Lesson

Sorting Equations and Identities

Mathematics Assessment Resource Service
University of Nottingham & UC Berkeley
Beta Version

For more details, visit: <http://map.mathshell.org>
© 2012 MARS, Shell Center, University of Nottingham
May be reproduced, unmodified, for non-commercial purposes under the Creative Commons license
detailed at <http://creativecommons.org/licenses/by-nc-nd/3.0/> - all other rights reserved

BEFORE THE LESSON

Assessment task: Equations and Identities (15 minutes)

Set this task, in class or for homework, a few days before the formative assessment lesson. This will give you an opportunity to assess the work, to find out the kinds of difficulties students have with it. You will then be able to target your help more effectively in the follow-up lesson.

Give each student a copy of the assessment task *Equations and Identities*.

Read through the questions and try to answer them as carefully as you can.

It is important that, as far as possible, students are allowed to answer the questions without your assistance.

Students should not worry too much if they cannot understand or do everything, because in the next lesson they will work on a similar task, which should help them. Explain to students that by the end of the next lesson, they should be able to answer questions such as these confidently. This is their goal.

Sorting Equations and Identities Student Materials Beta Version

Equations and Identities

1. Write down an example of an equation that has:

(a) One solution.

(b) Two solutions.

(c) An infinite number of solutions.

(d) No solutions.

2. For each of the following statements, indicate whether it is "Always true," "Never true," or "Sometimes true." Circle the correct answer. If you choose "Sometimes true" then state on the line below when it is true. The first one is done for you as an example.

$x + 2 = 3$	Always true	Never true	Sometimes true
	It is true when $x = 1$.		
$x - 12 = x + 30$	Always true	Never true	Sometimes true
	It is true when		
$2(x + 6) = 2x + 12$	Always true	Never true	Sometimes true
	It is true when		
$3(x - 2) = 3x - 2$	Always true	Never true	Sometimes true
	It is true when		
$(x + 4)^2 = x^2 + 4^2$	Always true	Never true	Sometimes true
	It is true when		
$x^2 + 4 = 0$	Always true	Never true	Sometimes true
	It is true when		

3. Which of the equations in question 2 are also identities?

.....

In your own words, explain what is meant by an identity.

.....

© 2011 MARS University of Nottingham S-1

Assessing students' responses

Collect students' responses to the task, and make some notes on what their work reveals about their current levels of understanding. The purpose of doing this is to forewarn you of the difficulties students will experience during the lesson itself, so that you may prepare carefully.

We suggest that you do not write scores on students' work. The research shows that this is counterproductive as it encourages students to compare scores, and distracts their attention from what they are to do to improve their mathematics.

Instead, help students to make further progress by asking questions that focus their attention on aspects of their work. Some suggestions for these are given on the next page. These have been drawn from common difficulties observed in trials of this unit.

We suggest that you write your own list of questions, based on your own students' work, using the ideas that follow. You may choose to write questions on each student's work. If you do not have time to do this, write a few questions that will help the majority of students. These can then be displayed on the board at the end of the lesson.

Common issues:	Suggested questions and prompts:
<p>Student writes expressions rather than equations For example: The student writes $y + 3$ for an equation with an infinite number of solutions.</p>	<ul style="list-style-type: none"> • What is the difference between an equation and an expression? • How can you change your expression to an equation?
<p>Student fails to include a variable in their equation For example: The student has written $5 + 5 = 10$ as an example of an equation with one solution.</p>	<ul style="list-style-type: none"> • Can you include an unknown number or a variable in the equation so that we can look at all possible values of that unknown?
<p>Student fails to provide an example of an equation with an infinite number of solutions</p>	<ul style="list-style-type: none"> • What would an equation with an infinite number of solutions look like?
<p>Student provides a quadratic with non-integer solutions as an example of an equation with no solutions For example: The student gives $x^2 + 8x + 13 = 0$ as an answer to Q1d. The student has assumed that, because it won't factorize there are no solutions.</p>	<ul style="list-style-type: none"> • Can a quadratic equation that will not factorize still have solutions/cross the x-axis? How can you check whether or not a quadratic equation has solutions?
<p>Student assumes that $-(x^2)$ is the same as $(-x)^2$ For example: The student classifies $x^2 + 4 = 0$ as true when $x = -2$.</p>	<ul style="list-style-type: none"> • What does $(-x)^2$ mean? What kind of number do we get when we multiply two negative numbers together? • Is x^2 positive or negative?
<p>Student correctly answers all the questions The student needs an extension task.</p>	<ul style="list-style-type: none"> • Use algebra to justify one of your answers to Question 2. • Draw a diagram to justify one of your answers to Question 2.

SUGGESTED LESSON OUTLINE

Whole-class introduction (10 minutes)

Use slide P-1 of the projector resource in this introduction.

Give each student a mini-whiteboard, a pen, and an eraser. Write the following equation on the board:

$$(x + 2)(y + 2) = xy + 4$$

Is this equation 'always true', 'never true' or 'sometimes true'? [Write 'always', 'never' or 'sometimes' on your whiteboard.]

Typically, most students will begin by saying that this is never true.

Can you show me values for x and y that make the equation false?

Can you show me values for x and y that make the equation true?

Hold a discussion about the responses, asking students to provide values for x and y to support their response.

Can the values of x and y be the same number? Can you figure out one?

This misconception needs to be explicitly addressed. Some students may assume that because x and y are different letters, they should take different values.

Students may spot that the equation is true when $x = y = 0$.

If students are struggling to find any values of x and y for which the equation is true, drawing an area diagram may be helpful (Slide P-1)

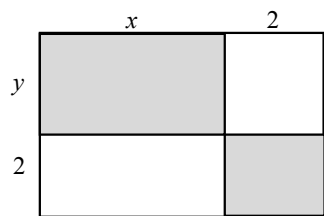

$$\text{Total area} = (x + 2)(y + 2)$$

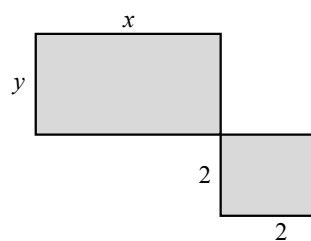

$$\text{Total area} = xy + 4$$

For these two area diagrams to be equal, what are the values of x and y ?

For the area diagrams to be equal, $2y$ must equal 0 and $2x$ must equal 0 . This is true when x and y are both equal to 0 .

When students are comfortable that when $x = y = 0$ the equation is true, ask them to summarize their findings.

We have found values of x and y that make the equation false and values of x and y that make the equation true. Is the equation always, sometimes or never true? [equation is sometimes true.]

Next, ask the students:

Are $x = 0$ and $y = 0$, the only values that make the equation true? How could we find out?

Using an algebraic approach here might be helpful, as we are unable to describe a negative area. The following method may be appropriate:

$$(x + 2)(y + 2) = xy + 2x + 2y + 4.$$

We want to know when this is the same as $xy + 4$, which must be when $2x + 2y = 0$, i.e. when $x + y = 0$ or when $x = -y$. We can therefore conclude that the equation is true when $x = -y$.

Now write this equation on the board:

$$(x + 2)(x - 2) = x^2 + 4$$

How about this equation? Is it 'always true', 'never true' or 'sometimes true'?

Students will probably find values for x for which the equation is false. After a discussion of a couple of these examples, encourage students to justify their conclusions:

Give me a value of x that will make the equation false/true? And another? [There are no values of x that will make the equation true.]

Do you think the equation is never true? Convince me. [Students should simplify the left side of the equation to $x^2 - 4$. The equation is never true, because $4 = -4$.]

After a few minutes, ask one or two students to explain their answers. Encourage other students to challenge their reasoning.

In this activity, the students use the term **identity**.

*If an equation is always true, we say it is an **identity**.*

Teachers may be accustomed to varying uses of the term 'identity'. While this is not the main focus of this activity, for the purpose of the lesson, the term 'identity' is used to describe equations that are always true.

Collaborative activity: Always, Sometimes, or Never True? (30 minutes)

Ask students to work in groups of two or three.

Give each group *Card Set: Always, Sometimes, or Never True?*, a large sheet of paper, a marker pen, and a glue stick.

Ask students to divide their large sheet into three columns and head respective columns with the words: *Always True, Sometimes True, Never True*.

You may want to use slide P-2 of the projector resource to display the following instructions.

You are now going to consider whether the equations on your desk are Always, Sometimes, or Never True.

In your groups, take turns to place a card in a column and justify your answer to your partner.

If you think the equation is sometimes true, you will need to find values of x for which it is true and values of x for which it is not true.

If you think the equation is always true or never true, you will need to explain how we can be sure that this is the case. Remember, showing it is true, or never true, for just a few values is not sufficient.

Another member of the group should then either explain their reasoning again in his or her own words, or challenge the reasons you gave.

It is important that everyone in the group understands the categorization of each card.

When everyone in the group agrees, glue the card onto your poster. Write the reason for your choice of category next to the card.

It does not matter if you do not manage to place all of the cards. It is more important that everyone in the group understands the categorization of each card.

The purpose of this structured work is to encourage each student to engage with their partner's explanations, and to take responsibility for their partner's understanding.

While students work in small groups you have two tasks: to make a note of student approaches to the task, and to support student reasoning.

Make a note of student approaches to the task

Listen and watch students carefully. In particular, listen to see whether students are addressing the difficulties they experienced in the assessment. You can use this information to focus the whole-class discussion towards the end of the lesson.

Support student reasoning

Use the questions in the *Common issues* table to help address misconceptions.

Encourage students to explain their reasoning carefully.

You have shown the statement is true for this specific value of x . Now convince me it is always true for every number!

Can you use algebra to justify your decision for this card?

Can you draw a diagram to explain your categorization for this card?

(Card 8) Can you sketch a graph to show why $x^2 = 2x$ has only two solutions?

(Card 9) Draw an area diagram to show that $(x + 3)^2$ means something different from $x^2 + 3^2$.

(Card 11) Can you draw an area diagram to show why $(3x)^2$ is always equal to $9x^2$?

If some students try to solve the equations by algebraic manipulation, they may notice that while sometimes this gives them possible solutions, sometimes they just get $0 = 0$. These are, of course, the identities. Equations that have no solutions give absurdities such as $1 = 2$.

If students finish the task quickly, ask them to create new examples.

Can you make up an identity? And another one?

Can you make up an equation that has two solutions?

Can you make up an equation that has no solutions and shows a common algebraic mistake? [E.g. $3(x + 4) = 3x + 4$.]

Whole-class discussion (20 minutes)

Organize a whole-class discussion about different methods of justification used for two or three equations.

Ask each group to choose an equation from their poster that meets some given criteria. For example:

Show me an equation that has no solutions.

Show me an equation that has just one solution. Write this solution on your mini-whiteboard.

Show me an equation that has two solutions. What are they?

Show me an equation that has an infinite number of solutions.

Show me an identity.

You may find that numerous different equations are displayed in response to a given criterion. If more than one group shows the same equation, ask each of these groups of students to give a justification of their thinking. Then ask other students to contribute ideas of alternative approaches, and their views on which reasoning method was easier to follow. It is important that students consider a variety of methods, and begin to develop a repertoire of approaches.

Why did you put this equation in this column? How else can you explain that decision?

Can anyone improve this explanation?

Which explanation do you prefer? Why?

Draw out issues you have noticed as students worked on the activity. Make specific reference to the misconceptions you noticed during the collaborative activity.

Improving individual solutions to the assessment task (10 minutes)

Return their original assessment *Equations and Identities* to the students, together with a second blank copy of the task.

Look at your original responses and think about what you have learned this lesson.

Using what you have learned, try to improve your work.

If you have not added questions to individual pieces of work, write your list of questions on the board. Students should select from this list only the questions they think are appropriate to their own work.

If you find you are running out of time, then you could set this task in the next lesson or for homework.

SOLUTIONS

Always true (Identities)	Sometimes true	Never true
$2(x + 3) = 2x + 6$	$x - 6 = 6 - x$ True when $x = 6$.	$2(x - 3) = 2x - 3$
$x^2 - 1 = (x + 1)(x - 1)$	$x + 6 = y + 6$ True when $x = y$.	$x^2 + 6 = 0$ (unless you include complex numbers.)
$(x - 6)^2 = (6 - x)^2$	$\frac{x}{6} = \frac{6}{x}$ True when $x = +6$ or -6 .	
$(3x)^2 = 9x^2$	$6 + 2x = 8x$ True when $x = 1$.	
	$x^2 = 2x$ True when $x = 0$ or 2 .	
	$(x + 3)^2 = x^2 + 3^2$ True when $x = 0$.	
	$(x + 1)(x + 4) = x^2 + 14$ True when $x = 2$.	
	$\frac{x + 6}{2} = x + 3$ True when $x = 0$.	

Equations and Identities

1. Write down an example of an equation that has:

(a) One solution.

(b) Two solutions.

(c) An infinite number of solutions.

(d) No solutions.

.....

.....

.....

.....

2. For each of the following statements, indicate whether it is 'Always true', 'Never true' or 'Sometimes true'. Circle the correct answer. If you choose 'Sometimes true' then state on the line below when it is true. The first one is done for you as an example.

$x + 2 = 3$	Always true	Never true	Sometimes true
	It is true when $x = 1$.		
$x - 12 = x + 30$	Always true	Never true	Sometimes true
	It is true when		
$2(x + 6) = 2x + 12$	Always true	Never true	Sometimes true
	It is true when		
$3(x - 2) = 3x - 2$	Always true	Never true	Sometimes true
	It is true when		
$(x + 4)^2 = x^2 + 4^2$	Always true	Never true	Sometimes true
	It is true when		
$x^2 + 4 = 0$	Always true	Never true	Sometimes true
	It is true when		

3. Which of the equations in question 2 are also identities?

.....

.....

In your own words, explain what is meant by an identity.

.....

.....

Card Set: Always, Sometimes, or Never True?

1 $x - 6 = 6 - x$	2 $x + 6 = y + 6$
3 $\frac{x}{6} = \frac{6}{x}$	4 $6 + 2x = 8x$
5 $2(x - 3) = 2x - 3$	6 $2(x + 3) = 2x + 6$
7 $\frac{x + 6}{2} = x + 3$	8 $x^2 = 2x$
9 $(x + 3)^2 = x^2 + 3^2$	10 $(x - 6)^2 = (6 - x)^2$
11 $(3x)^2 = 9x^2$	12 $x^2 - 1 = (x + 1)(x - 1)$
13 $x^2 + 6 = 0$	14 $(x + 1)(x + 4) = x^2 + 14$

Always, Sometimes, or Never True?

$$(x + 2)(y + 2) = xy + 4$$

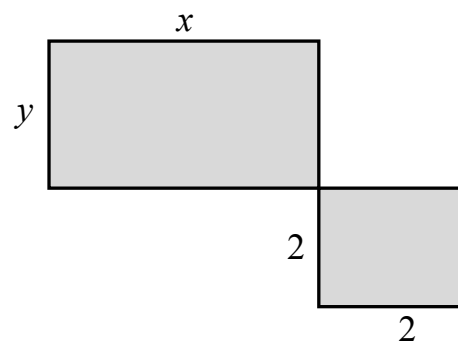
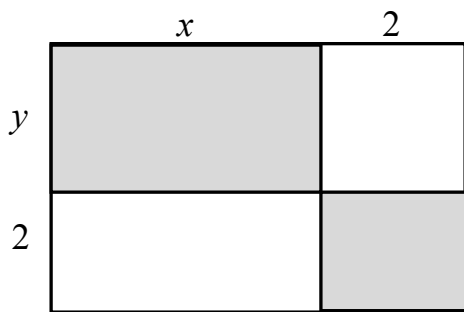

Always, Sometimes, or Never True?

- In your groups, take turns to place a card in a column and justify your answer to your partner.
- If you think the equation is ‘sometimes true’, find values of x for which it is true and values of x for which it is not true.
- If you think the equation is ‘always true’ or ‘never true’, explain how we can be sure that this is the case.
- Another member of the group should then either explain that reasoning again in his or her own words, or challenge the reasons you gave.
- When everyone in the group agrees, glue the card onto the poster. Write the reason for your choice next to the card.

Mathematics Assessment Project
CLASSROOM CHALLENGES

This lesson was designed and developed by the
Shell Center Team
at the
University of Nottingham
Malcolm Swan, Nichola Clarke, Clare Dawson, Sheila Evans
with
Hugh Burkhardt, Rita Crust, Andy Noyes, and Daniel Pead

It was refined on the basis of reports from teams of observers led by
David Foster, Mary Bouck, and Diane Schaefer
based on their observation of trials in US classrooms
along with comments from teachers and other users.

This project was conceived and directed for
MARS: Mathematics Assessment Resource Service
by
Alan Schoenfeld, Hugh Burkhardt, Daniel Pead, and Malcolm Swan
and based at the University of California, Berkeley

We are grateful to the many teachers, in the UK and the US, who trialed earlier versions
of these materials in their classrooms, to their students, and to
Judith Mills, Carol Hill, and Alvaro Villanueva who contributed to the design.

This development would not have been possible without the support of
Bill & Melinda Gates Foundation
We are particularly grateful to
Carina Wong, Melissa Chabran, and Jamie McKee

© 2012 MARS, Shell Center, University of Nottingham
This material may be reproduced and distributed, without modification, for non-commercial purposes,
under the Creative Commons License detailed at <http://creativecommons.org/licenses/by-nc-nd/3.0/>
All other rights reserved.
Please contact map.info@mathshell.org if this license does not meet your needs.

Equations

Lesson 4 of 5

Restructuring Equations

Description:

In this lesson, students will work to rearrange equations in order to solve for a desired variable.

Georgia Standards of Excellence Addressed:

- MGSE9-12.A.CED.1: Create equations and inequalities in one variable and use them to solve problems. Include equations arising from linear, quadratic, simple rational, and exponential functions (integer inputs only).
- MGSE9-12.A.CED.4: Rearrange formulas to highlight a quantity of interest using the same reasoning as in solving equations. Examples: Rearrange Ohm's law $V = IR$ to highlight resistance R ; Rearrange area of a circle formula $A = \pi r^2$ to highlight the radius.
- MGSE9-12.A.REI.1: Using algebraic properties and the properties of real numbers, justify the steps of a simple, one-solution equation. Students should justify their own steps, or if given two or more steps of an equation, explain the progression from one step to the next using properties.
- MGSE9-12.A.REI.2: Solve simple rational and radical equations in one variable, and give examples showing how extraneous solutions may arise.
- MGSE9-12.A.REI.3: Solve linear equations and inequalities in one variable including equations with coefficients represented by letters. For example, given $ax + 3 = 7$, solve for x .

Standard(s) for Mathematical Practice Emphasized:

- SMP 2: Reason abstractly and quantitatively.
- SMP 3: Construct viable arguments and critique the reasoning of others.
- SMP 7: Look for and make use of structure.

Sequence of
Instruction

Activities Checklist

Engage



Pose this question to students to introduce the lesson:
"How does a constant in an equation affect the solution?"

Direct students to the problem How Does the Solution Change? and give three to five minutes for students to think and discuss each equation with their group. (Students may need to be reminded of the difference in a variable and constant.)

INCLUDED IN THE STUDENT MANUAL

Task #8: How Does the Solution Change?

In the equations (a)-(d), the solution x to the equation depends on the constant a . Assuming a is positive, what is the effect of increasing a on the solution? Does it increase, decrease or remain unchanged? **Give a reason for your answer that can be understood without solving the equation.**

a) $x - a = 0$

b) $ax = 1$

c) $ax = a$

d) $\frac{x}{a} = 1$

(<http://www.illustrativemathematics.org/illustrations/614>)

Commentary for the Teacher:

The purpose of this task is to continue a crucial strand of algebraic reasoning begun at the middle school level. By asking students to reason about solutions without explicitly solving them, we get at the heart of understanding what an equation is and what it means for a number to be a solution to an equation. The equations are intentionally very simple; the point of the task is not to test technique in solving equations, but to encourage students to reason about them. This task is adapted from *Algebra: Form and Function*, McCallum et al., Wiley 2010.

Possible Solutions:

- Increases. The larger a is, the larger x must be to give 0 when a is subtracted from it.
- Decreases. The larger a is, the smaller x must be to give 1 when it is multiplied by a .
- Remains unchanged. This equation is obtained from the equation $x=1$ by multiplying both sides by a . So the solution is always the same, $x=1$.
- Increases. The larger a is, the larger x must be to give 1 when it is divided by a .

Facilitate a brief discussion about the four problems. The structure of the problems should be highlighted using questions like the following:

- What is it about subtraction and the fact that a is increasing that yielded your answer?
- What do we know must be true about x and a in problem d?
- What relationship occurs between a and x in problem b and what operations can be used to explain this relationship?
- What happens when an equation has more than one variable?
- How does this affect change?
- Instead of one variable, what happens if we have multiple variables and multiple constants?
- How does the structure of a problem and your ability to reason abstractly and with numbers help you arrive at an answer?

Have students work first as individuals on the following problem but then share work with a partner before a group discussion (Think-Pair-Class strategy).

INCLUDED IN THE STUDENT MANUAL

Task #9: Headphones

A store sells two brands of headphones: high definition (HD) and basic. It buys x HD headphones at z dollars each, and y basic headphones at w dollars each.

In a-c, write an equation whose solution is the given quantity. Do not solve the equations, just set them up.

- a) The number of basic headphones the store can purchase if it spends a total of \$10,000 on headphones and buys 110 HD headphones for \$70 each.
- b) The price the store pays for HD headphones if it spends a total of \$2,000 on headphones and buys 55 basic headphones for \$20 each.
- c) The price the store pays for HD headphones if it spends a total of \$800 on headphones and buys eight basic headphones for \$80 each.

Instructional Note:

For struggling students, it may help to guide them towards the general equation first. In other words, if the store spends a total of B dollars on headphones, then $B = xz + yw$. This information should NOT be given to the class upfront as some students will be able to provide this general equation. This should only be used as scaffolding for struggling students and to help guide the teacher's questioning.

Students may write $10,000 = 110(70) + yw$. Rather than saying, "wrong it's 'this,'" ask students to reread the question—what are they being asked to solve for? Students may either choose to rewrite through reasoning abstractly and quantitatively in their head (thinking about from a different approach) OR they could solve the equation above for y . Regardless, don't show and tell, rather, let the student grapple with how to use the structure of the symbols and/or the words to rewrite the problem for what is being asked.

Solutions:

a. $y = \frac{2300}{w}$

b. $z = \frac{900}{x}$

c. $z = \frac{160}{x}$

Briefly conclude by discussing the previous problem. The emphasis here is on setting up equations using the structure of the words and symbols to address the prompt.

Explore



Students should work in groups of two or three on the Illustrative Math task below. Their solutions and accompanying work should be recorded on chart paper to share with the class.

INCLUDED IN THE STUDENT MANUAL

Task #10: Buying a Car

Suppose a friend tells you she paid a total of \$16,368 for a car, and you'd like to know the car's list price (the price before taxes) so that you can compare prices at various dealers. Find the list price of the car if your friend bought the car in:

- Arizona, where the sales tax is 6.6%.
- New York, where the sales tax is 8.25%.
- A state where the sales tax is r .
- Solve for r in your answer to (c) above.

(Adapted from: <http://www.illustrativemathematics.org/illustrations/582>)

Possible Solutions:

- If p is the list price in dollars then the tax on the purchase is $0.066p$. The total amount paid is $p + 0.066p$, so

$$p + 0.066p = 16,368$$

$$(1 + 0.066)p = 16,368$$

$$p = \frac{16,368}{1 + 0.066} = \$15,354.60,$$

to the nearest penny.

- The total amount paid is $p + 0.0825p$, so

$$p + 0.0825p = 16,368$$

$$(1 + 0.0825)p = 16,386$$

$$p = \frac{16,368}{1 + 0.0825} = \$15,120.55.$$

- The total amount paid is $p + rp$, so

$$p + rp = 16,368$$

$$(1 + r)p = 16,368$$

$$p = \frac{16,368}{1 + r} \text{ dollars.}$$

$$d. r = \frac{16,638}{p} - 1$$

The crucial Standard(s) for Mathematical Practice continue to be SMP 2 and SMP 7. Therefore, as students work collaboratively, encourage them to understand the structure of their equations and the meaning of the quantities.

Explanation



Ask a couple of groups to present their answers to different parts of the *Buying a Car* problem. Encourage students to clearly explain their reasoning along the way. The additional question, d, may be difficult for students to solve. You can use this last question as a means of assessing the ability of students to manipulate equations before moving on to the next task.

The following questions may be used during the group presentations:

- In terms of the situation, how do you know that $p+0.066p$ and $(1+0.066)p$ are equivalent expressions?
- Why does $p = \frac{16,638}{1+r}$ make sense for the context of the problem?

Practice Together in Small Groups/Individually

Provide students with the formulas below to rearrange in order to solve for the indicated variable. Encourage students to use their knowledge they have been building in this unit to help guide their work. They should also be encouraged to check their work. For this set of problems, allow students to work in groups. An opportunity to assess their understanding individually will come later.

INCLUDED IN THE STUDENT MANUAL

Task #11: Literal Equations

- $A = hw$, solve for h .
- $P = 2w + 2h$, solve for w .
- $V = \pi r^2 h$, solve for h (or r if you have spent time with square roots).
- $h = v_0 t + \frac{1}{2}at^2$, solve for a .

Challenge Question:

$$\frac{2xy - 7}{3xy + 8} = 1, \text{ solve for } y.$$

Evaluate Understanding



Provide students with a number of equations, some of which come from situations students may have encountered. Possible equations could be taken from the Illustrative Math task titled: Equations and Formulas. The equations in this task are fairly simple and your students may need more challenging ones. Ask students to work on this individually to assess their understanding of the concept.

INCLUDED IN THE STUDENT MANUAL

Task #12: Equations and Formulas

Use inverse operations to solve the equations for the unknown variable or for the designated variable if there is more than one. If there is more than one operation to “undo,” be sure to think carefully about the order in which you do them. For equations with multiple variables, it may help to first solve a version of the problem with numerical values substituted in.

a. $5 = a - 3$

b. $A - B = C$ (solve for A)

c. $6 = -2x$

d. $IR = V$ (solve for R)

e. $\frac{X}{5} = 3$

f. $W = \frac{A}{L}$ (solve for A)

g. $7x + 3 = 10$

h. $ax + c = R$ (solve for x)

i. $13 = 15 - 4x$

j. $2h = w - 3p$ (solve for p)

k. $F = \frac{GMm}{r^2}$ (solve for G)

(<http://www.illustrativemathematics.org/illustrations/393>)

Commentary for the Teacher:

The first seven problems are pretty easy for students, but they are an important lead-in to part h. When students first encounter a problem like the one shown in part h, many try to simply write the answer down without following the same process as they do in other equations, giving them answers like $x = Ra + c$ or $x = Ra - c$.

Also, it never hurts to mention when equations that students run across are of physical significance: Part D is Ohm’s Law, relating the current I that flows through a conductive material (of resistance R) to the voltage V between the two ends. Part K is Newton’s law of universal gravitation, describing the strength of the force between two objects of masses M and m which are r units apart. The known value of Newton’s gravitational constant G , namely $G \approx 6.673 \times 10^{-11} \frac{\text{m}^3}{\text{kg} \cdot \text{s}^2}$, comes precisely from measuring the force, mass, and distance between various objects, and then solving the equation in K for G .

Possible Solution(s):

a) $5 = a - 3$

Addition is the inverse of subtraction, so add 3 to both sides: $a = 8$

b) $A - B = C$ (solve for A)

This equation has the same structure as the previous one. Addition is the inverse of subtraction, so add B to both sides: $A = C + B$

c) $6 = -2x$

Division is the inverse of multiplication, so divide both sides by -2: $x = -3$

d) $IR = V$ (solve for R)

This equation has the same structure as the previous one. Division is the inverse of multiplication, so divide both sides by I: $R = \frac{V}{I}$

e) $\frac{x}{5} = 3$

Multiplication is the inverse of division, so multiply both sides by 5: $x = 15$

f) $W = \frac{A}{L}$ (solve for A)

This equation has the same structure as the previous one. Multiplication is the inverse of division, so multiply both sides by L: $A = WL$

g) $7x + 3 = 10$

This equation involves multiplication and addition. If we were evaluating for x, the order of operations dictates that we would multiply and then add. To undo these operations, it is easiest to cancel them in the opposite order. (Otherwise we run into issues with distribution.) Thus, we first subtract 3 from both sides and then divide by 7: $x = 1$.

h) $ax + c = R$ (solve for x)

This equation has the same structure as the previous one. To undo the multiplication and addition, we first subtract c from both sides and then divide by a:

$$x = \frac{R - c}{a}$$

i) $13 = 15 - 4x$

This equation has multiplication and subtraction. Order of operations dictate that we would evaluate this equation for a given x by first multiplying by -4 and then adding 15, so we will do the inverses in the opposite order. First subtract 15 from both sides, and then divide both sides by -4, to get $x = \frac{13 - 15}{-4} = \frac{1}{2}$

j) $2h = w - 3p$ (solve for p)

This equation has the same structure as the previous one. First subtract w from both sides, and then divide by -3 to get $p = \frac{2h - w}{-3} = \frac{w - 2h}{3}$.

k) $F = \frac{GMm}{r^2}$ (solve for G)

First multiply both sides by r^2 , then divide both sides by Mm , resulting in $G = \frac{Fr^2}{Mm}$. To create an equation in the same form, simply replace the variables other than G with numbers. For example, the equation $10 = \frac{7x}{3}$ is in the same form. We would solve this by multiplying by 3 and dividing by 7, giving $x = \frac{30}{7}$.

Explanation



Ask students to trade their work with a partner. If they have differing answers, ask them to share their reasoning and come to a consensus. As you walk around, look for pairs where students had differing answers and have reached a consensus. Ask such a pair to recap their discussion with the rest of the class.

Homework/Independent Outside of Class Work:



As a closing activity, introduce students to the independent writing prompt of Pros and Cons. Students should orally discuss the prompt without writing and then be asked individually to organize their ideas in writing.

Individual writing prompt: *What are the PROS and CONS of rewriting an equation for a specified variable? Why might this be important? How does this relate to solving an equation with only one (maybe two) variables but with multiple constants?*

Students should be reminded to thoroughly explain their reasoning.

Notes:

Equations

Lesson 5 of 5

Inequalities

Description:

Students will explore the connection between equality and inequality. The behavior of inequalities in the negative number system is explored as well.

Georgia Standards of Excellence Addressed:

- MGSE9-12.A.SSE.3: Choose and produce an equivalent form of an expression to reveal and explain properties of the quantity represented by the expression.
- MGSE9-12.A.CED.1: Create equations and inequalities in one variable and use them to solve problems. Include equations arising from linear, quadratic, simple rational, and exponential functions (integer inputs only).
- MGSE9-12.A.CED.2: Create linear, quadratic, and exponential equations in two or more variables to represent relationships between quantities; graph equations on coordinate axes with labels and scales. (The phrase “in two or more variables” refers to formulas like the compound interest formula, in which $A = P(1 + r/n)^{nt}$ has multiple variables.)
- MGSE9-12.A.CED.3: Represent constraints by equations or inequalities, and by systems of equations and/or inequalities, and interpret data points as possible (i.e. a solution) or not possible (i.e. a non-solution) under the established constraints.
- MGSE9-12.A.REI.1: Using algebraic properties and the properties of real numbers, justify the steps of a simple, one-solution equation. Students should justify their own steps, or if given two or more steps of an equation, explain the progression from one step to the next using properties.
- MGSE9-12.A.REI.2: Solve simple rational and radical equations in one variable, and give examples showing how extraneous solutions may arise.
- MGSE9-12.A.REI.3: Solve linear equations and inequalities in one variable including equations with coefficients represented by letters. For example, given $ax + 3 = 7$, solve for x .

Standard(s) for Mathematical Practice Emphasized:

- SMP 1: Make sense of problems and persevere in solving them.
- SMP 2: Reason abstractly and quantitatively.
- SMP 7: Look for and make use of structure.

Sequence of Instruction

Activities Checklist

Engage



Explain the following game to your students:

- One player, Evan, will be given a number between zero and 999.
- Evan doubles the number and gives it to a second player, Megan.
- Whenever Megan gets a number, she adds 100 and passes the result back to Evan.
- Evan doubles the number and the game continues.
- The winner is the last person who produces a number less than 1,000.

Ask for two volunteers to play. You can randomize a number through a computer app or some other random process to start the game. Record the results turn by turn, including how many rounds of the game it requires before a winner is determined. You could organize results (or ask students to volunteer) on a table such as the one below:

Name	1	2	3	4
Evan	120	340	780	
Megan	240	680	1560	

In the example above, Megan wins in round three since Evan produced a number greater than 1,000.

You want to keep playing until somebody is given a relatively small number to start the game (otherwise it ends quickly). You also want to play at least one game where somebody gets a large number so the game ends immediately. Repeat as needed and liked. To keep students engaged, ask students to guess who will eventually win and how long they think it will take. Really encourage students to explain the reasoning they used in determining their answers. Try to find a student who uses a number line to visually graph the solution set. Otherwise, steer the class in this direction to be sure the recall they have other visual means to attack these questions.

Now together, convert this game into an inequality by asking the following question: What is the smallest possible number Evan could be given in which he would win in the first round?

The algebraic representation is $100 + 2n > 1,000$.

The quantitative reasoning is, as long as Megan generates a number greater than 1,000, Evan will win. Evan will generate $2n$. Megan will add 100 to $2n$. Thus we have $100 + 2n > 1,000$. It is important to read practical meaning into the structure of the inequality and throughout the steps in the solving process.

One method to solve the equation is to subtract 100 from both sides. Be sure somebody remarks that this is similar to how you solve equations. As long as you do the same (allowable) operation to both sides, you do not change the solution to an inequality. Somebody might ask about dividing by a negative being different, and explain they will be working in groups on some problems that address that issue. So we are left with $2n > 900$. Ask students why this makes sense in context of the game. (As long as Evan's number times two is greater than 100 less than 1,000, Evan will win

in round one.) Through class discussion, students should understand the process of solving the inequality mathematically (decontextualized) and contextualized into the game scenario.

Finally, dividing both sides by two, we see that whenever Evan gets a number $n > 450$, he will win in the first round. Use a number to illustrate how to visualize the solution set $n > 450$ on a number (closed dot versus open dot).

Now break students up into pairs and have them play a similar game to explore what happens when dividing by a negative number.

Explore



One issue students are likely to be unclear with is why and when do you switch the sign in an inequality. You can construct a similar game such as the one above to illustrate WHY we flip the sign, not just because it is a rule.

For example,

INCLUDED IN THE STUDENT MANUAL

Task #13: Evan and Megan

- Evan will be given a number between zero and 999.
- Evan multiplies the number by four and gives the result to Megan.
- Whenever Megan gets a number, she subtracts it from 2,000 and passes the result back to Evan.
- Evan multiplies that by four and passes the number back to Megan, etc.
- The winner is the last person who produces a number less than 1,000.

Break into pairs and record a couple of iterations of the game on a similar table:

Name	1	2	3	4
Evan	200	400		
Megan	800	1600		

In the example above, Megan wins in round two since Evan produced a number greater than 1,000.

Name	1	2	3	4
Evan	300			
Megan	1200			

In the example above, Megan wins in round one since Evan produced a number greater than 1,000. Thus we see in this case, large values cause Evan to lose whereas in the previous game, when Evan received a large number initially, he won. How can this situation be represented as an inequality? Work in your groups to set up and solve an inequality.

Ask the pairs to find the largest number Evan could initially be given so that he would win in the first round.

Solutions to Evan and Megan:

$$2000 - 4n > 1000.$$

$$-4n > -1000.$$

$$n < 250.$$

Explanation



Observe students working on the Evan and Megan scenario. Pay particular attention to students who have $n > 250$ and $n < 250$. Have a group put one of each of the solutions on the board if they both exist in the class.

Ask the class:

Which is correct? Why? Make sure to think about the context of the game and the winner. Who should the winner be? Do your results show this? Why does the sign flip? (Students should observe that if the initial value is large (or greater than 250) then Evan will not win the first round. If the initial value is small (less than 250) Evan will win the first round.

So it makes sense the sign is “flipped;” we want the values less than or equal to 250, $n < 250$.

Practice Together in Small Groups/Individually



Have students continue to reason why the sign flips by exploring the following situation.

INCLUDED IN THE STUDENT MANUAL

Task #14: Inequality Behavior

In each case, describe what operations occurred to move from the direct, previous line. Using what you know about the structure of our number system, make a decision for the inequality symbol.

Beginning Numbers	Description of operation	Inequality
2 5	Begin	$2 < 5$
4 10	Multiplied by 2	$4 < 10$
-1 5		$-1 > 5$
5 -25		$5 < -25$
15 -15		$15 < -15$
3 -3		$3 < -3$
-3 3		$-3 < 3$

What operations appear to be “flipping” the sign?

What is true about the negative number system?

Does adding and subtracting a negative number ALWAYS/SOMETIMES/NEVER produce an opposite number? Explain.

Does multiplying or dividing by a negative number ALWAYS/SOMETIMES/NEVER produce an opposite number? Explain.

Answers:

		Description of operation	Inequality
2	5	Begin	$2 < 5$
4	10	Multiply by 2	$4 < 10$
-1	5	Subtract 5	$-1 < 5$
5	-25	Multiply by -5	$5 > -25$
15	-15	Add 10	$15 > -15$
3	-3	Divide by 5	$3 > -3$
-3	3	Multiply (or divide) by -1	$3 < 3$

What operators appear to be “flipping” the sign?

Multiplying and dividing with a negative value.

What is true about the negative number system?

The negative number system moves towards the left instead of towards the right. For example $-1 > -2$ where as $1 < 2$ in positive numbers. This is due to the structure of the number line and the placement of numbers left to right on the real number line.

Does adding and subtracting a negative number ALWAYS/SOMETIMES/NEVER produce an opposite number? Explain.

Adding and subtracting with a negative number sometimes produces a negative number, but not always. The number will remain positive if the original number was positive and larger in magnitude than the negative value.

Does multiplying or dividing by a negative number ALWAYS/SOMETIMES/NEVER produce an opposite number? Explain.

Multiplying and dividing will always produce an opposite result. Multiplying (or dividing) a negative by a negative will produce a positive and likewise multiplying a positive by a negative will produce a negative number.

Either individually or in small groups, have students work on problems such as these:

INCLUDED IN THE STUDENT MANUAL

Task #15: Fishing Adventures

Fishing Adventures rents small fishing boats to tourists for day-long fishing trips. Each boat can only carry 1,200 pounds (lbs) of people and gear for safety reasons. Assume the average weight of a person is 150 pounds. Each group will require 200 pounds of gear for the boat plus 10 pounds of gear for each person.

- Create an inequality describing the restrictions on the number of people possible in a rented boat. Graph the solution set.
- Several groups of people wish to rent a boat. Group one has four people. Group two has five people. Group three has eight people. Which of the groups, if any, can safely rent a boat? What is the maximum number of people that may rent a boat?

(Illustrative Mathematics task Fishing Adventure 2
<http://www.illustrativemathematics.org/illustrations/643>)

Possible Solutions:

- a. Let p be the number of people in a group that wishes to rent a boat. Then $150p$ represents the total weight of the people in the boat, in pounds. Also, $10p$ represents the weight of the gear that is needed for each person on the boat. So the total weight in that boat that is contributed solely by the people is

$$150p + 10p = 160p$$

Because each group requires 200 pounds of gear regardless of how many people there are, we add this to the above amount. We also know that the total weight cannot exceed 1200 pounds. So we arrive at the following inequality:

$$160p + 200 \leq 1200$$

A graph illustrating the solutions is shown below. We observe that our solutions are values of p , listed below the number line and shown by the blue dots, so that the corresponding weights $160p + 200$, listed above the line, are below the limit of 1200 lbs.

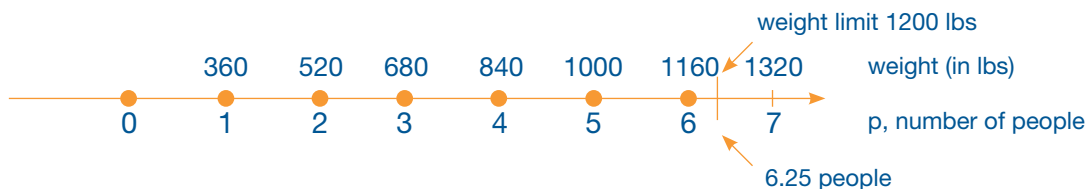

- b. We can find out which of the groups, if any, can safely rent a boat by substituting the number of people in each group for p in our inequality. We see that

$$\text{For Group 1: } 160(4) + 200 = 840 \leq 1200$$

$$\text{For Group 2: } 160(5) + 200 = 1000 \leq 1200$$

$$\text{For Group 3: } 160(8) + 200 = 1480 \not\leq 1200$$

We find that both Group 1 and Group 2 can safely rent a boat, but that Group 3 exceeds the weight limit, and so cannot rent a boat.

To find the maximum number of people that may rent a boat, we solve our inequality for p :

$$160p + 200 \leq 1200$$

$$160p \leq 1000$$

$$p \leq 6.25$$

As we cannot have 0.25 person, we see that 6 is the largest number of people that may rent a boat at once. This also matches our graph; since only integer values of p make sense, 6 is the largest value of p whose corresponding weight value lies below the limit of 1200 lbs.

INCLUDED IN THE STUDENT MANUAL

Task #16: Sports Equipment Set

Jonathan wants to save up enough money so that he can buy a new sports equipment set that includes a football, baseball, soccer ball, and basketball. This complete boxed set costs \$50. Jonathan has \$15 he saved from his birthday. In order to make more money, he plans to wash neighbors' windows. He plans to charge \$3 for each window he washes, and any extra money he makes beyond \$50 he can use to buy the additional accessories that go with the sports box set.

Write and solve an inequality that represents the number of windows Jonathan can wash in order to save at least the minimum amount he needs to buy the boxed set. Graph the solutions on the number line. What is a realistic number of windows for Jonathan to wash? How would that be reflected in the graph?

(From Illustrative Mathematics task Sports Equipment Set
<http://www.illustrativemathematics.org/illustrations/986>)

Possible Solutions:

We wish to find out how many windows Jonathan must wash, so let w be the number of windows. As he expects to get \$3 per window, we multiply these two quantities.

$$3w$$

This represents how much money Jonathan will make just from his window washing. Since he already has \$15 saved, we now add 15 to this amount.

$$3w + 15$$

Because we know that Jonathan needs a minimum of \$50, but could have more, we set this greater than or equal to 50.

$$3w + 15 \geq 50$$

We can solve this expression by first subtracting 15 from both sides, and then dividing both sides by 3 to isolate w .

$$3w + 15 \geq 50$$

$$3w \geq 35$$

$$w \geq \frac{35}{3} = 11\frac{2}{3}$$

Since we cannot (or should not) wash just $\frac{2}{3}$ of a window, it makes sense that we round this number up to 12. Thus, Jonathan must wash at least 12 windows in order to purchase the sports set. Note that this is just the minimum number he must wash, and washing more would be in his benefit, as he can purchase more sports accessories.

Using this information, and the fact that only whole numbers makes sense in this context, our solution can be graphed as follows.



There are other possible graphs, as the right hand endpoint can be determined based on a discussion based on what would be “realistic” based on, for example, how many neighbors Jonathan has, how many windows are in each house, and how much time he has to wash windows. The point of the questions is to have students realize that a context limits the solution set even when other numbers satisfies the accompanying inequality.

Have students solve inequalities similar to the following:

a) $2x-6 < -3x+9$

b) $-3x+5 > 5x+13$

c) $\frac{(-3x+2)}{4} \geq 5$

Solutions:

a) $x < 3$

b) $x < -1$

c) $x \leq -6$

Evaluate Understanding

Have students share answers with each other, perhaps in pairs matching answers, and discussing questions they disagreed about.

Closing Activity

INCLUDED IN THE STUDENT MANUAL

Task #17: Basketball

Chase and his brother like to play basketball. About a month ago, they decided to keep track of how many games they have each won. As of today, Chase has won 18 out of the 30 games against his brother.

- How many games would Chase have to win in a row in order to have a 75% winning record?
- How many games would Chase have to win in a row in order to have a 90% winning record?
- Is Chase able to reach a 100% winning record? Explain why or why not.
- Suppose that after reaching a winning record of 90% in part (b), Chase had a losing streak. How many games in a row would Chase have to lose in order to drop down to a winning record below 55%?

Possible Solutions:

- a. Currently, Chase has a winning record of 60%:

$$\frac{18 \text{ games won}}{30 \text{ games played}} = 0.6$$

Clearly Chase has to win some more games to raise his win percent to 75%. Then in order to determine a winning record of 75% we need to add x amount of games to 18, and x amount of games to 30 and set this equal to 0.75:

$$\frac{18 + x}{30 + x} = 0.75$$

$$18 + x = 0.75(30 + x)$$

$$18 + x = 22.5 + 0.75x$$

$$0.25x = 4.5$$

$$x = 18$$

So chase will bring his win percent up to 75% if he wins the next 18 games.

- b. The mechanics of this part are identical to the previous, replacing the desired 0.75 win record with 0.9:

$$\frac{18 + x}{30 + x} = 0.9$$

$$18 + x = 0.9(30 + x)$$

$$18 + x = 27 + 0.9x$$

$$0.1x = 9$$

$$x = 90$$

So Chase will bring his win percent up to 90% if he wins the next 90 games.

- c. No, because in order to have a 100% winning record, Chase will have needed to win every game. We can see this is not the case because he won 18 out of 30; in other words, he had already lost 12 out of 30, and cannot change this fact no matter how many more games he plays. It's interesting to see where the algebra from the previous two parts breaks down: If x were the number of games Chase could win to get to a 100% winning record, we would have

$$\frac{18 + x}{30 + x} = 1$$

$$18 + x = 30 + x$$

$$18 = 30$$

which is clearly false.

- d. After reaching a 90% winning record by winning 90 consecutive games. Chase has won 108 out of 120 games. If he were to lose x consecutive games from this point, we would have a record of 108 wins out of 120 + x game. For this win percent to be less than 0.55, we solve:

$$\frac{108}{120 + x} < 0.55$$

$$108 < 0.55(120 + x)$$

$$108 < 66 + 0.55x$$

$$42 < 0.55x$$

$$76.36 < x$$

So Chase will need to lose the next 77 games in order for his win percentage to drop below 55%.

INCLUDED IN THE STUDENT MANUAL

Task #18: Solving Inequalities

Solve each of the following. Explain each step in your work, and check your answers.

1. Jane plans to purchase three pairs of slacks all costing the same amount, and a blouse that is \$4 cheaper than one of the pairs of slacks. She has \$75 to spend but wants to have at least \$3 left. What is the price range for the slacks?
2. $(-3x + 7) - 4(2x - 6) - 12 \geq 7$
3. $-3(5x - 3) < 4(x + 3) - 12$

Solutions:

1. $75 - [3s + (s - 4)] \geq 3$
 $s \leq 19$
2. $(-3x + 7) - 4(2x - 6) - 12 \geq 7$
 $x \leq \frac{12}{11}$
3. $-3(5x - 3) < 4(x + 3) - 12$
 $x > \frac{9}{19}$

Resources/Instructional Materials Needed:

- Random number generator (optional)

Notes:

SREB Readiness Courses
Transitioning to college and careers

College Readiness Mathematics

Unit 2 . Equations
Student Manual
Version 3

Name



Unit 2 . Equations

Table of Contents

Lesson 1.....	3
Lesson 2.....	7
Lesson 4.....	10
Lesson 5.....	16

Task #1: New Shoes

You want to buy a new pair of shoes. While looking around at different shoes and styles online, you see a coupon for \$10 off a pair of shoes at a local retailer in town. When you arrive at the store, you see they have sale, 15% off any pair of shoes in stock, but you are not allowed to apply any additional discounts. You do the math to decide whether the coupon or the 15% discount will save you the most money, and you find out the discounted price is the same no matter whether you use the coupon or receive 15% off from the sale. How much did the pair of shoes cost?

Task #3: Gasoline Cost

You have \$40 to spend on n gallons of gas that costs \$3.25 per gallon. Determine whether each of the following is an expression or an equation. Using the structure, give an interpretation of the practical meaning of each.

1. $3.25n$

2. $3.25n = 26$

3. $40 - 3.25n$

4. $40 - 3.25n = 1.00$

Task #4: Equations and Solutions

For each of the equations below, determine whether the given value is a solution or not.

1. $x + 2 = x^2 + 4$ at $x = 2$

2. $p + 2 = p^2 - 4$ at $p = -2$

3. $\frac{a-5}{a+5} = 1$ at $a = 0$

4. $\frac{5-a}{5+a} = -1$ at $a = 0$

5. $3(x-8) = 3x-8$ at $x = 0$

6. Which, out of the numbers 0, 1, -1, 2, -2, is/are solution(s) to the equation $4x^2 - 4x - 5 = 2x(x+3) - 1$?

Task #5: Same Solution?

Which of the following equations have the same solution? Give reasons for your answer that do not depend on solving the equations.

I. $x + 3 = 5x - 4$

II. $x - 3 = 5x + 4$

III. $2x + 8 = 5x - 3$

IV. $10x + 6 = 2x - 8$

V. $10x - 8 = 2x + 6$

VI. $0.3 + \frac{x}{10} = \frac{1}{2}x - 0.4$

(Source: Illustrative Mathematics)

Task #6: Equivalent or Not?

For each pair of equations, determine whether the second equation is the result of a valid operation on the first. If so, what is the operation?

1. $7 + 5x = 3 - 2x$ and $7 + 7x = 3$

2. $3(x - 4) = 15$ and $x - 4 = 15$

3. $x^2 = 6x$ and $x = 6$

4. $\frac{1}{(x - 5)} = 10$ and $1 = 10(x - 5)$

Task #7: Study Questions

You and a friend are getting ready to study for an assessment on expressions and equations. Knowing that your friend is still getting expressions and equations mixed up and doesn't always know how to tell if two expressions or two equations are equivalent, your job is to create a set of problems (and solutions) to help your friend study. Create a minimum of six problems that will address your friend's misconceptions and include the solutions for her/him to study. Make sure your reasoning is clearly articulated in the solutions.

Task #8: How Does the Solution Change?

In the equations (a)-(d), the solution x to the equation depends on the constant a . Assuming a is positive, what is the effect of increasing a on the solution? Does it increase, decrease or remain unchanged? **Give a reason for your answer that can be understood without solving the equation.**

a) $x - a = 0$

b) $ax = 1$

c) $ax = a$

d) $\frac{x}{a} = 1$

(Source: Illustrative Mathematics)

Task #9: Headphones

A store sells two brands of headphones: high definition (HD) and basic. It buys x HD headphones at z dollars each, and y basic headphones at w dollars each.

In a-c, write an equation whose solution is the given quantity. Do not solve the equations, just set them up.

- a) The number of basic headphones the store can purchase if it spends a total of \$10,000 on headphones and buys 110 HD headphones for \$70 each.

- b) The price the store pays for HD headphones if it spends a total of \$2,000 on headphones and buys 55 basic headphones for \$20 each.

- c) The price the store pays for HD headphones if it spends a total of \$800 on headphones and buys eight basic headphones for \$80 each.

Task #10: Buying a Car

Suppose a friend tells you she paid a total of \$16,368 for a car, and you'd like to know the car's list price (the price before taxes) so that you can compare prices at various dealers. Find the list price of the car if your friend bought the car in:

a) Arizona, where the sales tax is 6.6%.

b) New York, where the sales tax is 8.25%.

c) A state where the sales tax is r .

d) Solve for r in your answer to (c) above.

(Source: Illustrative Mathematics)

Task #11: Literal Equations

a) $A = hw$, solve for h .

b) $P = 2w + 2h$, solve for w .

c) $V = \pi r^2 h$, solve for h (or r if you have spent time with square roots).

d) $h = v_0 t + \frac{1}{2} a t^2$, solve for a .

e) $\frac{(2xy - 7)}{3xy + 8} = 1$, solve for y .

Task #12: Equations and Formulas

Use inverse operations to solve the equations for the unknown variable or for the designated variable if there is more than one. If there is more than one operation to “undo,” be sure to think carefully about the order in which you do them. For equations with multiple variables, it may help to first solve a version of the problem with numerical values substituted in.

a. $5 = a - 3$

b. $A - B = C$ (solve for A)

c. $6 = -2x$

d. $IR = V$ (solve for R)

e. $\frac{x}{5} = 3$

f. $W = \frac{A}{L}$ (solve for A)

g. $7x + 3 = 10$

h. $ax + c = R$ (solve for x)

i. $13 = 15 - 4x$

j. $2h = w - 3p$ (solve for p)

k. $F = \frac{GMm}{r^2}$ (solve for G)

(Source: Illustrative Mathematics)

Task 13: Evan and Megan

- Evan will be given a number between zero and 999.
- Evan multiplies the number by four and gives the result to Megan.
- Whenever Megan gets a number, she subtracts it from 2,000 and passes the result back to Evan.
- Evan multiplies that by four and passes the number back to Megan, etc.
- The winner is the last person who produces a number less than 1,000.

Break into pairs and record a couple of iterations of the game on a similar table:

Name	1	2	3	4
Evan	200	400		
Megan	800	1600		

In the example above, Megan wins in round two since Evan produced a number greater than 1,000.

Name	1	2	3	4
Evan	300			
Megan	1200			

In the example above, Megan wins in round one since Evan produced a number greater than 1,000. Thus we see in this case, large values cause Evan to lose whereas in the previous game, when Evan received a large number initially, he won.

How can this situation be represented as an inequality? Work in your groups to set up and solve an inequality.

Task #14: Inequality Behavior

In each case, describe what operations occurred to move from the direct, previous line. Using what you know about the structure of our number system, make a decision for the inequality symbol.

Beginning Numbers	Description of operation	Inequality
2 5	Begin	$2 < 5$
4 10	Multiplied by 2	$4 < 10$
-1 5		$-1 > 5$
5 -25		$5 < -25$
15 -15		$15 < -15$
3 -3		$3 < -3$
-3 3		$-3 < 3$

What operations appear to be “flipping” the sign?

What is true about the negative number system?

Does adding and subtracting a negative number ALWAYS/SOMETIMES/NEVER produce an opposite number? Explain.

Does multiplying or dividing by a negative number ALWAYS/SOMETIMES/NEVER produce an opposite number? Explain.

Task #15: Fishing Adventures

Fishing Adventures rents small fishing boats to tourists for day-long fishing trips. Each boat can only carry 1,200 pounds (lbs) of people and gear for safety reasons. Assume the average weight of a person is 150 pounds. Each group will require 200 pounds of gear for the boat plus 10 pounds of gear for each person.

- a) Create an inequality describing the restrictions on the number of people possible in a rented boat. Graph the solution set.

- b) Several groups of people wish to rent a boat. Group one has four people. Group two has five people. Group three has eight people. Which of the groups, if any, can safely rent a boat? What is the maximum number of people that may rent a boat?

(Source: Illustrative Mathematics)

Task #16: Sports Equipment Set

Jonathan wants to save up enough money so that he can buy a new sports equipment set that includes a football, baseball, soccer ball, and basketball. This complete boxed set costs \$50. Jonathan has \$15 he saved from his birthday. In order to make more money, he plans to wash neighbors' windows. He plans to charge \$3 for each window he washes, and any extra money he makes beyond \$50 he can use to buy the additional accessories that go with the sports box set.

Write and solve an inequality that represents the number of windows Jonathan can wash in order to save at least the minimum amount he needs to buy the boxed set. Graph the solutions on the number line. What is a realistic number of windows for Jonathan to wash? How would that be reflected in the graph?

(Source: Illustrative Mathematics)

Task #17: Basketball

Chase and his brother like to play basketball. About a month ago they decided to keep track of how many games they have each won. As of today, Chase has won 18 out of the 30 games against his brother.

- a. How many games would Chase have to win in a row in order to have a 75% winning record?

- b. How many games would Chase have to win in a row in order to have a 90% winning record?

- c. Is Chase able to reach a 100% winning record? Explain why or why not.

- d. Suppose that after reaching a winning record of 90% in part (b), Chase had a losing streak. How many games in a row would Chase have to lose in order to drop down to a winning record below 55%?

(Source: Illustrative Mathematics)

Task #18: Solving Inequalities

Solve each of the following. Explain each step in your work, and check your answers.

1. Jane plans to purchase three pairs of slacks all costing the same amount, and a blouse that is \$4 cheaper than one of the pairs of slacks. She has \$75 to spend but wants to have at least \$3 left. What is the price range for the slacks?

2. $(-3x + 7) - 4(2x - 6) - 12 \geq 7$

3. $-3(5x - 3) < 4(x + 3) - 12$

(Source: Illustrative Mathematics)

SREB

SREB Readiness Courses
Transitioning to college and careers

Math Ready

Unit 3 . Measurement and
Proportional Reasoning
Version 3

Southern
Regional
Education
Board

592 Tenth Street, NW
Atlanta, GA 30318
(404) 875-9211

www.sreb.org

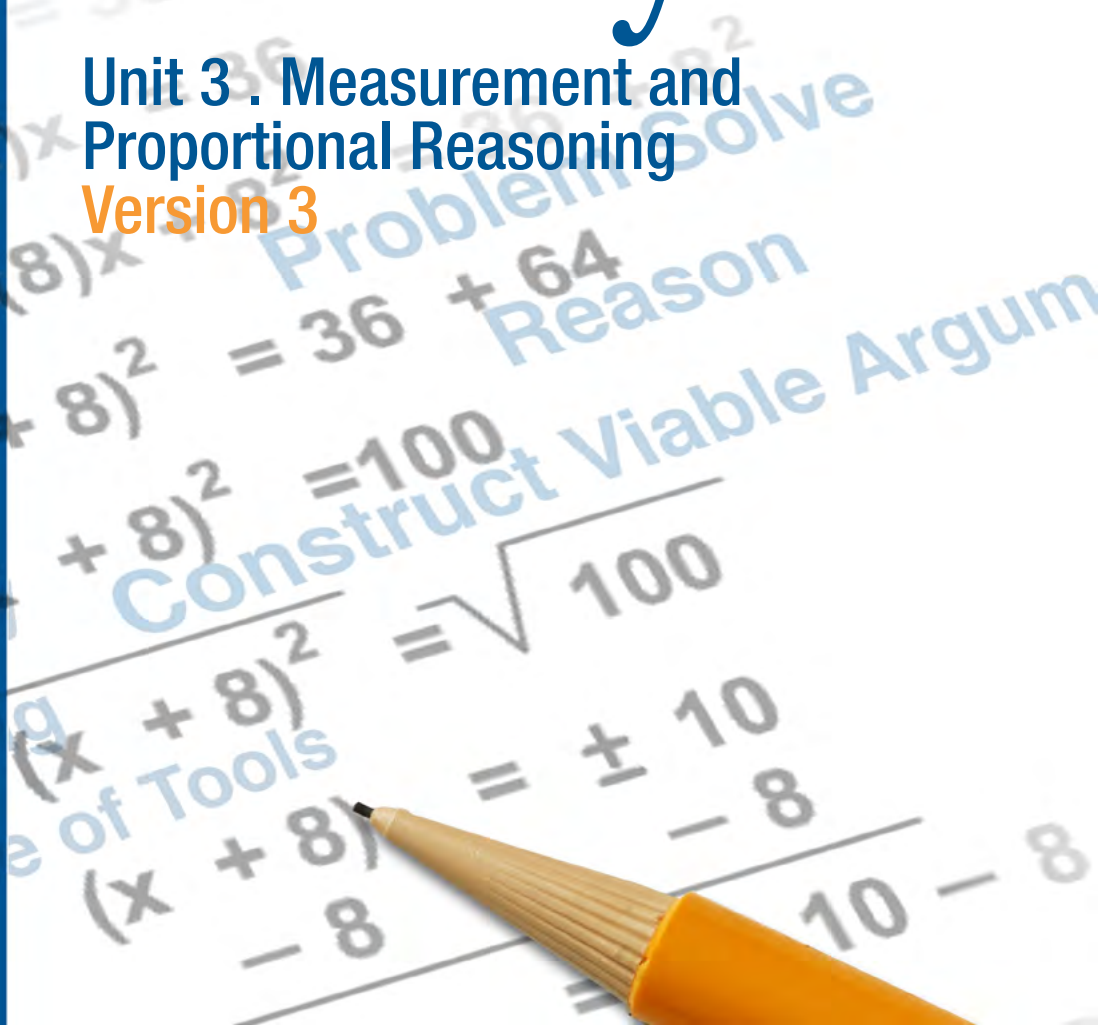

Unit 3 . Measurement and Proportional Reasoning

Overview

Purpose

This unit was designed to solidify student conception of a variety of standard measurements commonly encountered in life situations. Students working in this unit will develop a greater depth of knowledge related to the measurement domain. Activities found in the beginning lessons concentrate on prerequisite concepts and skills typically found at the middle-grades level to provide a strong foundation. As the lessons progress throughout the unit, the measurement concept is further developed to a college readiness level. A variety of activities are provided to allow students and teachers to address the diversity of measurements found throughout mathematics. The goal is to have students solve multi-step problems that involve planning or converting units of measure and to solve word problems containing rates and proportions.

Essential Questions:

What does it mean to have number sense?

How do you identify an appropriate unit of measure in a given situation?

What is the purpose of a scale drawing?

What is the relationship between the perimeter and the area of a figure? The surface area and the volume?

How do you maximize or minimize the area or surface area of a figure given the perimeter?

Georgia Standards of Excellence:

Quantities

Reason quantitatively and use units to solve problems.

- MGSE9-12.N.Q.1: Use units of measure (linear, area, capacity, rates, and time) as a way to understand problems:
 - a. Identify, use, and record appropriate units of measure within context, within data displays, and on graphs;
 - b. Convert units and rates using dimensional analysis (English-to-English and Metric-to-Metric without conversion factor provided and between English and Metric with conversion factor);
 - c. Use units within multi-step problems and formulas; interpret units of input and resulting units of output.
- MGSE9-12.N.Q.2: Define appropriate quantities for the purpose of descriptive modeling. Given a situation, context, or problem, students will determine, identify, and use appropriate quantities for representing the situation.

Expressing Geometric Properties with Equations

Use coordinates to prove simple geometric theorems algebraically.

- MGSE9-12.G.GPE.4: Use coordinates to prove simple geometric theorems algebraically. For example, prove or disprove that a figure defined by four given points in the coordinate plane is a rectangle; prove or disprove that the point $(1, \sqrt{3})$ lies on the circle centered at the origin and containing the point $(0,2)$. (Focus on quadrilaterals, right triangles, and circles.)
- MGSE9-12.G.GPE.7: Use coordinates to compute perimeters of polygons and areas of triangles and rectangles, e.g., using the distance formula.

Geometric Measurement and Dimension

Explain volume formulas and use them to solve problems.

- MGSE9-12.G.GMD.1: Give informal arguments for geometric formulas.
 - a. Give informal arguments for the formulas of the circumference of a circle and area of a circle using dissection arguments and informal limit arguments.
 - b. Give informal arguments for the formula of the volume of a cylinder, pyramid and cone using Cavalieri's principle.
- MGSE9-12.G.GMD.3: Use volume formulas for cylinders, pyramids, cones, and spheres to solve problems.

Modeling with Geometry

Apply geometric concepts in modeling situation.

- MGSE9-12.G.MG.2: Apply concepts of density based on area and volume in modeling situations (e.g., persons per square mile, BTUs per cubic foot).
- MGSE9-12.G.MG.3: Apply geometric methods to solve design problems (e.g., designing an object or structure to satisfy physical constraints or minimize cost; working with typographic grid systems based on ratios)

Prior Scaffolding Knowledge / Skills:

- Understand the concept of a ratio and use ratio reasoning to solve problems.
- Students should be able to connect ratio reasoning to proportional relationships and use these relationships to solve real-world and mathematical problems.
- Students should have basic understandings of area, surface area and volume.
- Students should be able to solve real-life and mathematical problems involving area, surface area and volume of two and three dimensional figures.

Lesson Progression Overview:

Lesson Big Idea	Lesson Details	Georgia Standards of Excellence	Standards for Mathematical Practice
Lesson 1: Number Sense and Units	This unit begins with acquainting students with unit conversion using time. Students will perform conversions in a setting with which they can relate thus building confidence. This lesson encompasses concepts they will learn in health and science class by looking at heart rate in different situations.	MGSE9-12.N.Q.1	SMP 2 SMP 6 SMP 8
Lesson 2: Number Sense and Ratios	This lesson involves an activity that has students think about miles per gallon versus gas consumption. This activity guides students to use mathematical reasoning to determine patterns in fuel consumption. The analysis requires care in using appropriate units of measure while developing a mathematical model to be analyzed.	MGSE9-12.N.Q.1 MGSE9-12.N.Q.2	SMP 2 SMP 3 SMP 4
Lesson 3: Number Sense and Proportions	This lesson extends the thinking of human heart rate as introduced in lesson 1, to a more open-ended research question involving ratios and proportions whereby students are tasked with accepting or refuting an urban legend that there exists a formula for determining a particular species' life span. Students will use units of measurement as well as ratios and proportions involving multi-step processes to accept or refute the claim.	MGSE9-12.N.Q.1 MGSE9-12.N.Q.2	SMP 1 SMP 3 SMP 4
Lesson 4: Number Sense and Scaling	This lesson begins with an activity to evaluate number sense and get students thinking about rates. Also included is an activity using the Golden Ratio and other real-world problems involving ratios and rates. Students have the opportunity to measure objects with instruments other than a traditional ruler and understand how to convert the lengths to more traditional units such as inches or centimeters. At the end of this lesson, students create their own scale drawings.	MGSE9-12.N.Q.1	SMP 5 SMP 6 SMP 7
Lesson 5: Area and Perimeter	This lesson asks students to look at area and perimeter, solving problems involving maximizing or minimizing area. Students begin a multiple day immersion into the conceptual and applied use of area and perimeter.	MGSE9-12.G.MG.3	SMP 1 SMP 3 SMP 4 SMP 6

Lesson Big Idea	Lesson Details	Georgia Standards of Excellence	Standards for Mathematical Practice
Lesson 6: Optional Project Maximizing Area and Perimeter	Students will continue to look at area and perimeter, solving problems involving maximizing or minimizing area. This is the continuation of the multiple day immersion into the conceptual and applied use of area and perimeter. In this lesson, students will use features of their graphing calculators to examine how area can be maximized.	MGSE9-12.G.MG.3	SMP 2 SMP 3 SMP 4 SMP 7 SMP 8
Lesson 7: Coordinate Connections	Students will use coordinates to prove simple geometric theorems and to explain some geometric formulas.	MGSE9-12.G.GPE.4 MGSE9-12.G.GPE.7 MGSE9-12.G.GMD.1	SMP 2 SMP 3 SMP 4 SMP 7 SMP 8
Lesson 8: Area, Surface Area, and Volume	This lesson will allow students to perform hands-on activities to deepen their understanding of the relationships between area, surface area, and volume.	MGSE9-12.G.GMD.1 MGSE9-12.G.GMD.3	SMP 2 SMP 3 SMP 5 SMP 6 SMP 7
Lesson 9: Formative Assessment Lesson: Evaluating Statements About Enlargements (2D and 3D)	<p>This lesson is intended to help the student and teacher assess how well students are able to conceptualize and solve problems involving area and volume. In particular, the lesson is used to help identify and assist students who have difficulties with the following:</p> <ul style="list-style-type: none"> • Computing perimeters, areas and volumes using formulas. • Finding the relationships between perimeters, areas, and volumes of shapes after scaling. 	MGSE9-12.G.GMD.1 MGSE9-12.G.GMD.3	SMP 3 SMP 7
Lesson 10: Formative Assessment Lesson: Calculating Volumes of Compound Objects	<p>This lesson unit is intended to help the student and teacher assess how well students are able to conceptualize and solve problems involving measurement. In particular, the lesson is used to identify and help students who have the following difficulties:</p> <ul style="list-style-type: none"> • Computing measurements using formulas. • Decomposing compound shapes into simpler ones. • Using right triangles and their properties to solve real-world problems. 	MGSE9-12.G.GMD.1 MGSE9-12.G.GMD.3	SMP 1 SMP 6

Measurement and Proportional Reasoning

Lesson 1 of 8

Number Sense and Units

Description:

This unit begins with acquainting students with unit conversion using time. Students will perform conversions in a setting with which they can relate thus building confidence. This lesson encompasses concepts they will learn in health and science class by looking at heart rate in different situations.

Georgia Standards of Excellence Addressed:

- MGSE9-12.N.Q.1: Use units of measure (linear, area, capacity, rates, and time) as a way to understand problems:
 - a. Identify, use, and record appropriate units of measure within context, within data displays, and on graphs;
 - b. Convert units and rates using dimensional analysis (English-to-English and Metric-to-Metric without conversion factor provided and between English and Metric with conversion factor);
 - c. Use units within multi-step problems and formulas; interpret units of input and resulting units of output.

Standard(s) for Mathematical Practice Emphasized:

- SMP 2: Reason abstractly and quantitatively.
- SMP 6: Attend to precision.
- SMP 8: Look for and express regularity in repeated reasoning.

Sequence of
Instruction

Activities Checklist

Engage

Entry Event: To gauge number and measurement sense, ask students how many times they believe an average person's heart beats in 1 minute. Discuss what range of answers would be deemed reasonable and why.

Explore



Ask students to attend to precision as you lead them in a discussion regarding heart rate:

- A. Approximately how many times would your heart beat while running a 5K race?
What's a number that's too high? What's a number that's too low? *Answers will vary.*
- B. How would you measure your heart rate? *Beats per minute.*

- C. How could you get a quick estimate of your heart rate? *Count your pulse for 10 seconds and multiply by 6 to find beats per minute.*
- D. How would you get a more accurate reading of your heart rate? *Answers will vary, but may include counting the beats for an entire minute, taking many readings throughout a day to find an average, taking readings at the same time each day, etc.*

See the American Heart Association website for more information. http://www.heart.org/HEARTORG/HealthyLiving/PhysicalActivity/FitnessBasics/Target-Heart-Rates_UCM_434341_Article.jsp#

Explanation



Engage students in quantitative reasoning practices that include attending to the meaning of quantities and considering the units involved.

1. Students work in groups of 2 – 4 people.
2. Give each group one set of questions from the Heart Rate Problems found below. (If you have a large class, multiple groups can be given the same set of questions.) Consider letting students work first in expert groups to “solve” their task card. Each student should have a complete solution and be able to explain this work to any peer. As students are working in this group, assign each student a letter (A, B, C, D, etc.).
3. While groups are working on the problems above, the teacher should circulate, asking guiding questions to address any misconceptions. This is also a time for teachers to make note of student work that are good models for students to share with the class, whether the solution was “perfect”, or may exhibit a misconception, or was approached from a different perspective. The teacher should encourage students to solve these problems by using proportional reasoning, dimensional analysis, and unit analysis strategies.

Here are some examples of guiding questions:

- What units are usually used to measure heart rate?
 - What does an average heart rate mean?
 - What are some causes of increased or decreased heart rates?
4. After groups have completed their cards, have all A’s meet together, all B’s, etc. In this group, each student has to explain their task card to the other members and justify their work. The remaining group members should ask clarifying questions to the presenter. Each student should share their task to this “home” group.
 5. As a “wrap up” have each “home” group write three statements comparing and contrasting the work of the groups.
 - What did each group do similarly?
 - What did the groups do differently?
 - What strategies were the easiest to follow? Why?

This is an alternative to having a large group discussion. Facilitating in this manner allows more students to talk and holds individual students more accountable for their own learning. Additionally, it ensures that all students have had access to all problems.

Measurement and Proportional Reasoning

Heart Rate Problems

Jenna's heart rate is 60 beats per minute.

- 1. If this is her average heart rate, how many times will her heart beat in 30 years?**
- 2. If Jenna's heart beat 604,800 times, how many full days would have elapsed?**
- 3. If Jenna's heart beat 747,533 times, how much time has elapsed? Give your answer in days, hours and minutes. (Round to the nearest minute.)**

Bob's heart rate is 72 beats per minute.

- 1. If this is his average heart rate, how many times will his heart beat in 25 years?**
- 2. If Bob's heart beat 604,800 times, how many full days would have elapsed?**
- 3. If Bob's heart beat 747,533 times, how much time has elapsed? Give your answer in days, hours and minutes. (Round to the nearest minute.)**

Ava's heart rate is 65 beats per minute.

- 1. If this is her average heart rate, how many times will her heart beat in 10 years?**
- 2. If Ava's heart beat 604,800 times, how many full days would have elapsed?**
- 3. If Ava's heart beat 747,533 times, how much time has elapsed? Give your answer in days, hours and minutes. (Round to the nearest minute.)**

Caiden's heart rate is 70 beats per minute.

- 1. If this is his average heart rate, how many times will his heart beat in 40 years?**
- 2. If Caiden's heart beat 604,800 times, how many full days would have elapsed?**
- 3. If Caiden's heart beat 747,533 times, how much time has elapsed? Give your answer in days, hours and minutes. (Round to the nearest minute.)**

Heart Rate Problems Solutions

Jenna

1. 946,080,000 beats
2. 7 days
3. 8 days, 15 hours, 39 minutes

Bob

1. 946,080,000 beats
2. 5.83333333 days
3. 7 days, 5 hours, 2 minutes

Ava

1. 341,640,000 beats
2. 6.4615 days
3. 7 days, 23 hours, 41 minutes

Caiden

1. 1,471,680,000 beats
2. 6 days
3. 7 days, 9 hours, 59 minutes

Practice Together / in Small Groups / Individually

Students will continue working on the Heart Rate Problems. At the end of the *Exploration* lesson, all students should be able to understand how to approach problems with proportional reasoning, including units of measure. This activity provides students with an approach to addressing problems of this type.

Evaluate Understanding

Students complete the Heart Rate Closing Activity and record their results to the questions below.

INCLUDED IN THE STUDENT MANUAL

Task #1: Heart Rate Closing Activity

1. Find your pulse and count how many times it beats in 15 seconds.
2. Run (in place if necessary) for 2 minutes. Now take your pulse for 15 seconds. Record your result.
3. At this rate, how long would it take for your heart to beat 700,000 times? Express your answer in days. Now express your answer in days, hours, minutes, and seconds. (example: 2 days, 4 hours, 21 minutes, 15 seconds)
4. You are training for a 5K race. This morning you ran 8 miles in 1 hour. If you run the race at this speed, how many minutes will it take you to run a 5K race?

Measurement and Proportional Reasoning

Lesson 2 of 8

Number Sense and Ratios

Description:

This lesson involves an activity that has students think about miles per gallon versus gas consumption. This activity guides students to use mathematical reasoning to determine patterns in fuel consumption. The analysis requires care in using appropriate units of measure while developing a mathematical model to be analyzed.

Georgia Standards of Excellence Addressed:

- MGSE9-12.N.Q.1: Use units of measure (linear, area, capacity, rates, and time) as a way to understand problems:
 - a. Identify, use, and record appropriate units of measure within context, within data displays, and on graphs;
 - b. Convert units and rates using dimensional analysis (English-to-English and Metric-to-Metric without conversion factor provided and between English and Metric with conversion factor);
 - c. Use units within multi-step problems and formulas; interpret units of input and resulting units of output.
- MGSE9-12.N.Q.2: Define appropriate quantities for the purpose of descriptive modeling. Given a situation, context, or problem, students will determine, identify, and use appropriate quantities for representing the situation.

Standard(s) for Mathematical Practice Emphasized:

- SMP 2: Reason abstractly and quantitatively.
- SMP 3: Construct viable arguments and critique the reasoning of others.
- SMP 4: Model with mathematics.

Sequence of
Instruction

Activities Checklist

Engage

Math Is Fun Questions

A Kahoot has been created (goo.gl/ai6EWx) using the following questions to engage students in sense making with unit analysis. A free account is needed to play the game, so be sure to register before beginning the activity. You may alternatively choose to create a PowerPoint using the questions below to engage students in the discussion using whiteboards. A PowerPoint with the following questions is available. The bold response is the correct response. Permission was granted to use these questions from:

Pierce, Rod. "Metric Speed (Velocity)" Math Is Fun. Ed. Rod Pierce. 2 Jun 2012. 25 Aug 2012 <<http://www.mathsisfun.com/measure/metric-speed.html>>

1. Which the following could be the cruising speed of a jet liner?
A. 90 km/h
B. 900 km/h
C. 9,000 km/h
D. 90,000 km/h
2. Which one of the following could be the speed of a bicycle?
A. 800 m/s
B. 80 m/s
C. 8 m/s
D. 0.8 m/s
3. A boat has a speed of 36 km/h. What is its speed in m/s?
A. 10 m/s
B. 12.96 m/s
C. 100 m/s
D. 129.6 m/s
4. A racing car has a speed of 240 km/h. What is its speed in m/s?
A. 864 m/s
B. 666.67 m/s
C. 86.4 m/s
D. 66.67 m/s
5. A car has a speed of 25 m/s. What is its speed in km/hr?
A. 6.94 km/h
B. 9 km/h
C. 69.44 km/h
D. 90 km/h
6. The speed of the space shuttle in orbit was 7,850 m/s. What was its speed in km/h?
A. 2,180.6 km/h
B. 2,826 km/h
C. 22,500 km/h
D. 28.260 km/h
7. A cheetah can run at an average speed of 108 km/h. What is its speed in m/s?
A. 18 m/s
B. 30 m/s
C. 300 m/s
D. 388.8 m/s
8. A sloth crawled 6 cm in one second. What was its speed in km/h?
A. 0.167 km/h
B. 0.5 km/h
C. 0.216 km/h
D. 0.36 km/h

Explore



National Council of Teachers of Mathematics' activity *Fuel for Thought* (<http://www.nctm.org/Standards-and-Positions/Focus-in-High-School-Mathematics/Reasoning-and-Sense-Making-Task-Library/Fuel-for-Thought/>) asks students to use mathematical reasoning to determine patterns in fuel consumption. The analysis requires care in using appropriate units of measure while developing a mathematical model to be analyzed. Students are asked to analyze given information on fuel consumption to determine which of two new car options would result in saving more fuel.

Introduce the activity, distribute *Student Activity Sheet - Part 1*, and ask students to work on this part of the activity in pairs or small groups.

Working in pairs of small groups will allow students to build on one another's knowledge and gain a deeper understanding of the mathematical patterns and relationships that they are seeking.

Note that in this problem, the relationship between miles per gallon (mpg) and fuel consumption is inversely proportional, meaning that doubling the mpg halves the fuel consumption. Although students are not likely to recognize the relationship initially, the activity should help them arrive at that realization.

If necessary, help a group of students get started or think about the relationship more deeply by asking, "What is the question asking us to compare?"

Questioning will help students build new mathematical knowledge through problem solving. Asking questions may help students realize that they need to analyze the problem more fully.

INCLUDED IN THE STUDENT MANUAL

Task #3: Fuel for Thought – Student Activity Sheet Part 1

A Fuel-ish Question

1. Which of the following would save more fuel?
 - a. Replacing a compact car that gets 34 miles per gallon (mpg) with a hybrid that gets 54 mpg.
 - b. Replacing a sport utility vehicle (SUV) that gets 18 mpg with a sedan that gets 28 mpg.
 - c. Both changes would save the same amount of fuel.
2. Explain your reasoning for your choice.

<http://www.nctm.org/Standards-and-Positions/Focus-in-High-School-Mathematics/Reasoning-and-Sense-Making-Task-Library/Fuel-for-Thought/>

Possible Solution:

Students might conclude that choice (a) saves more fuel, since in this case the mpg increases by 20, whereas with choice (b) it increases only by 10. Note that this comparison of choices (a) and (b) is additive.

Two typical student responses follow:

1. “I think choice (a) saves more fuel, since the change from 34 mpg to 54 is an increase of about 59 percent, but the 18 to 28 mpg change is an increase of only about 56 percent.”
2. “It looks to me as though choice (b) is better, since you will save more fuel by switching from the SUV to the sedan:

For switching from the compact car to the hybrid:

$100 \text{ miles} / 54 \text{ mpg} = 1.85 \text{ gallons used for the hybrid.}$

$100 \text{ miles} / 34 \text{ mpg} = 2.94 \text{ gallons used for the compact car.}$

So switching from a 34-mpg to a 54-mpg car would save 1.09 gallons of gas.

For switching from the SUV to the sedan:

$100 \text{ miles} / 28 \text{ mpg} = 3.57 \text{ gallons used for the sedan.}$

$100 \text{ miles} / 18 \text{ mpg} = 5.56 \text{ gallons used for the SUV.}$

So switching from a 18-mpg to a 28-mpg car saves 1.99 gallons of gas every 100 miles. That means that you are actually saving more gas by replacing the SUV than by replacing the compact car.”

Explanation



After several minutes, bring the class together, and have students compare the answers that they have determined. Seek a variety of answers from a range of students.

If no student makes a case for choice (b), the conclusion that in the situation replacing the SUV by the sedan would save more fuel than replacing the compact car by the hybrid, you might ask (or ask again), “What is the task asking you to compare?”

You could then continue by asking the class questions such as, “Is the problem asking which new car would get more miles per gallon?” or, “How could we tell which new car would actually save more fuel?”

After giving the class an opportunity to debate the merits of the two choices, (a) and (b), ask the students to work in small groups to explore the relationship of mpg to actual gasoline consumption, perhaps by making a graph or a table or completing the table in *Fuel for Thought – Student Activity Sheet - Part 2* of the activity sheet.

Debate among students requires the students to reflect on possible solutions and analyze and evaluate the mathematical thinking and strategies of others, as well as to develop their own mathematical arguments. Using multiple representations of mathematical ideas allows students to see different approaches to the problem. Students should always be encouraged to generalize a solution.

INCLUDED IN THE STUDENT MANUAL

Task #4: Fuel for Thought – Student Activity Sheet Part 2

Extending the Discussion – MPG vs. Fuel Consumption

1. Complete the following chart comparing mpg and fuel consumption.

MPG	Fuel consumed to travel 100 miles

2. Use your values to sketch a graph.

3. Summarize your observations and conclusions in 2-3 sentences.

In the student summaries, students should conclude that as the mpg increases, the increments in the amount of fuel saved become smaller. An online applet can help students explore the relationship (see <http://www.mathrsm.net/applets/fuel>). Note: Applet requires java.

By producing a written group report, students will have to develop and communicate their ideas and arguments more fully than if they are required only to summarize their thinking verbally.

Ask students to discuss the merits of different units used to measure fuel efficiency, for example, mpg vs. gallons per 100 miles. You might note in closing that in other countries, fuel efficiency is reported in the latter manner, although using liters and kilometers.

Listen to group presentations and see whether students can articulate and justify the relationships that they found.

• **Off the Scale: Illuminations Map Problem**

To assess students' prior knowledge, have the students brainstorm ideas about where they might use a scale to enlarge or reduce the size of something. Use a strategy like Sticky-Note Storm or the Whip Around Strategy (links provided below).

To begin the lesson, give the students a copy of their state map and have them locate the legend. Maps of individual states are available at <http://geology.com/state-map/>. Alternatively, students can find their own state map.

Give pairs of students a ruler and have them figure out distances between given cities. Use the Map Activity Sheet as a guideline to creating your own worksheet.

INCLUDED IN THE STUDENT MANUAL

Task #5: Map Activity Sheet

You are planning a trip from _____ to _____ on Highway _____.
(city name) (city name) (Route)

You want to determine the distance between these cities by using the map. On the map, locate the legend showing the scale of miles and answer the following questions.

1. How many miles are represented by 1 inch on the map?
2. How many inches represent 5 miles? How did you get your answer?
3. How many inches are there between the two cities listed above?
4. How many miles are there between these two cities?

Questions for students:

- What mathematics are involved in enlarging something? Reducing something? (Proportions, similarity, scale factor.)
- What mathematics do you use to convert inches to miles (on the map) using the scale on the map? (Scale, conversion factor).
- What steps do you take to convert miles to feet? How about miles to yards? (To convert miles to feet, divide miles by 5,280. To convert miles to yards, divide miles by 1,760.)

(Full activity found at <https://illuminations.nctm.org/lesson.aspx?id=1675>)

Evaluate Understanding

- **Unit Conversion Problems:** Teacher should encourage students to solve these problems by using proportional reasoning, dimensional analysis, and unit analysis strategies.

Suggested Guiding Questions for the following practice problems:

- What is asked in this problem?
- What information is needed to solve the problem?
- Is all of the information available?
- Is extraneous information provided?

INCLUDED IN THE STUDENT MANUAL

Task #6: Unit Conversion Problems

Medicine: A doctor orders 250 mg of Rocephin to be taken by a 19.8 lb infant every 8 hours. The medication label shows that 75-150 mg/kg per day is the appropriate dosage range. Is this doctor's order within the desired range?

Agriculture: You own an empty one acre lot. (640 acres = 1 mi²; 1 mi = 5,280 ft)

- If 1 inch of rain fell over your one acre lot, how many cubic inches of water fell on your lot?
- How many cubic feet of water fell on your lot?
- If 1 cubic foot of water weighs about 62 pounds, what is the weight of the water that fell on your lot?
- If the weight of 1 gallon of water is approximately 8.3 pounds, how many gallons of water fell on your lot?

Astronomy: Light travels 186,282 miles per second.

- How many miles will light travel in one year? (Use 365 days in a year) This unit of distance is called a light-year.
- Capella is the 6th brightest star in the sky and is 41 light-years from earth. How many miles will light from Capella travel on its way to earth?
- Neptune is 2,798,842,000 miles from the sun. How many hours does it take light to travel from the sun to Neptune?

Unit Conversion Practice Problems Solutions

- Minimum dosage: $75\text{mg/kg per day} \times 1\text{kg}/2.2\text{ lb} \times 19.8\text{ lb} = 675\text{ mg/day}$
Maximum dosage: $150\text{mg/kg per day} \times 1\text{kg}/2.2\text{ lb} \times 19.8\text{ lb} = 1350\text{ mg/day}$
Doctor's order: 250 mg every 8 hr results in 3 doses per day or 750 mg/day
Doctor's order is within the desired range.
- You own an empty one acre lot. (640 acres = 1 mi²; 1 mi = 5,280 ft)
 - $1\text{mi}^2/640\text{acre} \times (5280\text{ft})^2/(1\text{mi})^2 \times (12\text{in})^2/(1\text{ft})^2 \times 1\text{in} = 6,272,640\text{ in}^3$
 - $6,272,640\text{ in}^3 \times (1\text{ ft})^3/(12\text{ in})^3 = 3630\text{ ft}^3$
 - $3630\text{ ft}^3 \times 62\text{ lb}/1\text{ ft}^3 = 225,060\text{ lb}$
 - $225,060\text{ lb} \times 1\text{ gal}/8.3\text{ lb} = 27,116\text{ gal}$
- Light travels 186,282 miles per second.
 - $186,282\text{ mi/sec} \times 60\text{ sec}/1\text{ min} \times 60\text{ min}/1\text{ hr} \times 24\text{ hr}/1\text{ day} \times 365\text{ days/yr} = 5.874589 \times 10^{12}\text{ mi/yr}$
 - $5.874589 \times 10^{14}\text{mi}/1\text{ light-year} \times 41\text{ light-years} = 2.408581 \times 10^{14}\text{mi}$
 - $2,798,842,000\text{ mi} \times 1\text{ yr}/5.874589 \times 10^{14}\text{mi} \times 365\text{ days}/1\text{ yr} \times 24\text{ hr}/1\text{ day} = 4.17\text{hr}$

Measurement and Proportional Reasoning

Lesson 3 of 8

Number Sense and Proportions

Description:

This lesson extends the thinking of human heart rate as introduced in lesson 1, to a more open-ended research question involving ratios and proportions whereby students are tasked with accepting or refuting an urban legend that there exists a formula for determining a particular species' life span. Students will use units of measurement as well as ratios and proportions involving multi-step processes to accept or refute the claim.

Georgia Standards of Excellence Addressed:

- MGSE9-12.N.Q.1: Use units of measure (linear, area, capacity, rates, and time) as a way to understand problems:
 - a. Identify, use, and record appropriate units of measure within context, within data displays, and on graphs;
 - b. Convert units and rates using dimensional analysis (English-to-English and Metric-to-Metric without conversion factor provided and between English and Metric with conversion factor);
 - c. Use units within multi-step problems and formulas; interpret units of input and resulting units of output.
- MGSE9-12.N.Q.2: Define appropriate quantities for the purpose of descriptive modeling. Given a situation, context, or problem, students will determine, identify, and use appropriate quantities for representing the situation.

Standard(s) for Mathematical Practice Emphasized:

- SMP 1: Make sense of problems and persevere in solving them.
- SMP 3: Construct viable arguments and critique the reasoning of others.
- SMP 4: Model with mathematics.

Sequence of
Instruction

Activities Checklist

Engage



Pose the following to students:

I recently came across a theory called the *Heartbeat Hypothesis*. Some view the *Heartbeat Hypothesis* as an “urban legend.”

The heartbeat hypothesis postulates that every living creature has a limited number of heartbeats or breaths. The hypothesis is based on two observations. First, that small mammals (such as a mouse) have rapid resting heart rate compared to a larger mammal

(such as an elephant), and that their respective lifespans are inversely proportional to those rates. Second, is that athletically fit people tend to have a lower resting heart rate and tend to live longer than unhealthy people. Essentially, there is a claim that there is a formula reflecting this relationship indicating that a species has a life span of approximately one billion heartbeats.

Students should discuss with a partner their initial acceptance or rejection of this claim.

Teacher Note: Here is a quote from the popular children’s book **Matilda**:

“Did you know”, Matilda said suddenly, “that the heart of a mouse beats at the rate of six hundred and fifty times a second?”

I did not,” Miss Honey said smiling. “How absolutely fascinating. Where did you read that?”

“In a book from the library,” Matilda said. “And that means it goes so fast that you can’t even hear the separate beats. It must sound like a buzz.”

“It must,” Miss Honey said.

Reading this and/or showing this clip from the movie may be interesting to the students as they consider the heart rate hypothesis above.

Explore



In pairs, students should research the question: “Does every species get around a billion heartbeats on average?” This question will direct students to numerous websites that pose the heartbeat hypothesis and offer reports both in support and in denial of the question. If students do not have access to technology you can provide printouts from both sides of the argument using the links below. Ask students to look for specific mathematical reasoning and proof supplied by contributors on either side of the debate.

A small sampling of the sites that contain this debate are:

- <http://skeptics.stackexchange.com/questions/5701/does-every-species-get-around-a-billion-heartbeats-on-average>
- <http://kottke.org/13/02/does-every-species-get-a-billion-heartbeats-per-lifetime>
- <http://www.itsokaytobesmart.com/post/42619263293/does-every-species-get-around-a-billion-heartbeats>

Many of the websites that students will encounter include the following chart displaying alleged data regarding the number of heartbeats a species has in a lifetime along with their average heart rates and longevity.

Lifetime Heartbeats and Animals Size

Creature	Weight (grams)	Heart Rate (1/minute)	Longevity (years)	Product	Lifetime Heartbeats (billions)
Human	90000	60	70	4200	2.21
Cat	2000	150	15	2250	1.18
Small dog	2000	100	10	1000	0.53
Medium dog	5000	90	15	1350	0.71
Large dogs	8000	75	17	1275	0.67

Lifetime Heartbeats and Animals Size

Creature	Weight (grams)	Heart Rate (1/minute)	Longevity (years)	Product	Lifetime Heartbeats (billions)
Hamster	60	450	3	1350	0.71
Chicken	1500	275	15	4125	2.17
Monkey	5000	190	15	2850	1.50
Horse	1200000	44	40	1760	0.93
Cow	800000	65	22	1430	0.75
Pig	150000	70	25	1750	0.92
Rabbit	1000	205	9	1845	0.97
Elephant	5000000	30	70	2100	1.1
Giraffe	900000	65	20	1300	0.68
Large Whale	120000000	20	80	1600	0.84

Students should read the data in the chart (assuming the data to be true) and establish and analyze relationships they generate to either support or change their initial acceptance/rejection of the claim made in the engage section above.

Teacher’s Note: The chart above shows “weight” as a column heading, but gives the units as grams. Mass should always be used when measuring in grams. Use this as a teachable moment to have a discussion about what this chart (that is bound to be found during student research) and that everything students read or see is not always mathematically correct.

Explanation



Student pairs create posters (using chart paper) providing mathematical evidence using the concepts of measurement, ratio & proportions to support their position (accept or reject) regarding the Heartbeat Hypothesis. Student pairs construct viable arguments supporting their findings and must be prepared to share.

Posters should be displayed as students present their findings to the class. Classmates should critique the reasoning used by their peers as they explain the information on their posters.

The teacher should act as a facilitator, being prepared to ask probing questions regarding the proportional relationships that students identify.

If students are having difficulty getting started or need pushed to expand their thinking, probing questions might include:

- Can a relationship between be found between the heart rate and life span of various species?
- Can the weight (or surface area or volume) of the species be used in a relationship with another variable to support the 1 million heartbeat life span claim?

Practice Together / in Small Groups / Individually

Keeping in theme with animal species, ask students to accept or refute claims that David M. Schwartz makes in his children’s book, **If You Hopped Like a Frog** (ISBN-13: 978-0590098571).

The book asks the student to imagine, with the help of ratio and proportion, what he could accomplish if he could hop like a frog or eat like a shrew. He would certainly be a shoo-in for the Guinness World Records. The book first shows what a person could do if he or she could hop proportionately as far as a frog or were proportionately as powerful as an ant. At the back of the book, the author explains each example and poses questions at the end of the explanations.

Assign each individual or pair of students to a few of the animals and their unique talents (presented in conditional formats) along with the “animal fact sheets” provided in the back of the book.

For example, one student might be assigned the chameleon. The conditional statement reads: If you flicked your tongue like a chameleon, you could whip the food off your plate without using your hands! (But what would your mother say?) The illustration provided shows a child with an extraordinary long tongue lapping up—around the circumference of a dinner plate—all the food in one swipe.

The challenge is for the student to provide evidence supporting or refuting this claim based on the “animal fact sheet.”

Chameleon fact sheet: A one-foot chameleon may have a 6-inch tongue.

This is multi-step problem in that the student has to recognize that the chameleon’s tongue is one-half it’s body length and then establish how long his tongue would be “if” he had this unique trait. Further, he must then determine the length his tongue would need to be in order to reach from a seated position to the dinner plate on the table and swipe its circumference in order to accept or refute author David M. Schwartz’ claim.

Evaluate Understanding

Have individual or student pairs assigned in the ‘practice together’ section to join with another individual or pair and share their findings. Students should act as peer reviewers, asking probing questions and critiquing the reasoning of their sharing partners.

The teacher should rotate throughout the room listening to conversations and asking clarifying questions as necessary to correct any misunderstandings that may occur.

Closing Activity

Ask various students to present their solutions to the problems above while the other students critique their reasoning, solution paths and answers.

Measurement and Proportional Reasoning

Lesson 4 of 8

Number Sense and Scaling

Description:

This lesson begins with an activity to evaluate number sense and get students thinking about rates. Also included is an activity using the Golden Ratio and other real-world problems involving ratios and rates. Students have the opportunity to measure objects with instruments other than a traditional ruler and understand how to convert the lengths to more traditional units such as inches or centimeters. At the end of this lesson, students create their own scale drawings.

Georgia Standards of Excellence Addressed:

- MGSE9-12.N.Q.1: Use units of measure (linear, area, capacity, rates, and time) as a way to understand problems:
 - a. Identify, use, and record appropriate units of measure within context, within data displays, and on graphs;
 - b. Convert units and rates using dimensional analysis (English-to-English and Metric-to-Metric without conversion factor provided and between English and Metric with conversion factor);
 - c. Use units within multi-step problems and formulas; interpret units of input and resulting units of output.

Standard(s) for Mathematical Practice Emphasized:

- SMP 5: Use appropriate tools strategically.
- SMP 6: Attend to precision.
- SMP 7: Look for and make use of structure.

Sequence of
Instruction

Activities Checklist

Engage



Throughout the lesson, teachers should reinforce vocabulary such as dilation, scale factor, and ratio.

Students will be comparing two scale drawings, one drawing of the Washington Monument and one drawing of the Eiffel Tower, in this activity.

INCLUDED IN THE STUDENT MANUAL

Task #7: Scaling Activity

Look at the two pictures below. The first picture is the Washington Monument in Washington DC. The second is of the Eiffel Tower in France.

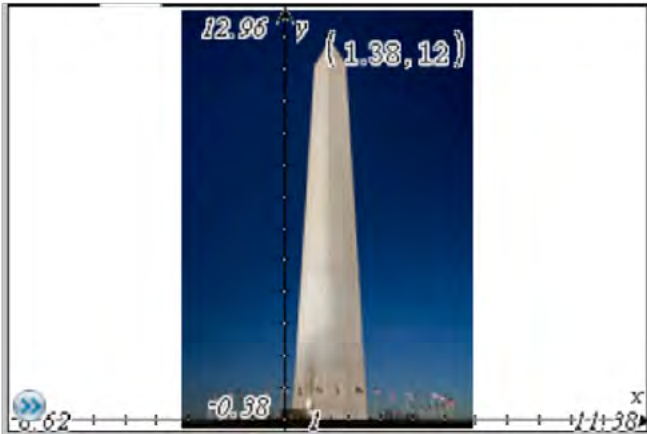

Washington Monument

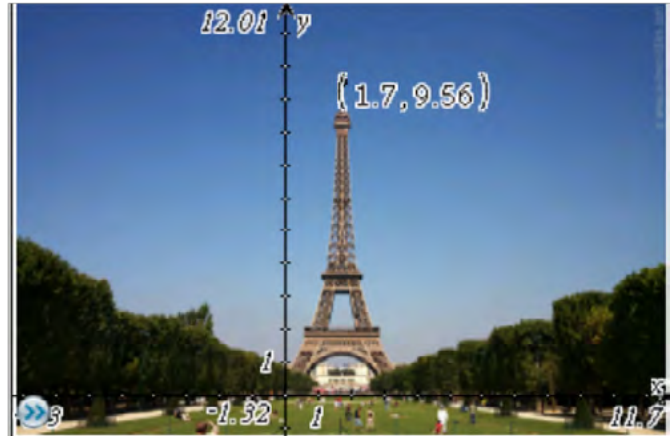

Eiffel Tower

If you just look at the diagrams which appears to be the taller object?

The scale for the Washington Monument is 1 unit \approx 46.25 feet.
The scale for the Eiffel Tower is 1 unit \approx 33.9 meters.

Round your answers to the nearest whole number.

- A. Find the height of the Washington Monument.

- B. Find the height of the Eiffel Tower.

Now let's think about the original question posed, which of the monuments is actually taller? What will we have to do with our answers from A and B above to find the solution? Show and explain your work for this problem below.

Have students work in groups of 2 or 3.

Ask students to discuss results of the Washington Monument/Eiffel Tower scale activity, keeping in mind appropriate and precise use of terms such as scale factor, ratio, dilation, etc.

Scaling Activity Solution

Round your answers to the nearest whole number.

A. Find the height of the Washington Monument. **555 ft**

$$\text{Height} = 46.25 \text{ ft} \times 12 = 555 \text{ ft}$$

B. Find the height of the Eiffel Tower. **324 m**

$$\text{Height} = 33.9 \text{ m} \times 9.56 = 324 \text{ m}$$

Now let's think about the original question posed, which of the monuments is actually the taller? What will we have to do with our answers from A and B above to find the solution? Show and explain your work for this problem below.

Eiffel Tower is taller.

Washington Monument: 555 ft or 169 m

$$\text{Height} = 46.25 \text{ ft} \times 12 = 555 \text{ ft}$$

$$555 \text{ ft} \times 12 \text{ in}/1 \text{ ft} \times 1 \text{ m}/39.37 \text{ in} = 169 \text{ m (rounded to the nearest meter)}$$

Eiffel Tower: 1063 ft or 324 m

$$\text{Height} = 33.9 \text{ m} \times 9.56 = 324 \text{ m}$$

$$324 \text{ m} \times 39.37 \text{ in}/1 \text{ m} \times 1 \text{ ft}/12 \text{ in} = 1063 \text{ ft (rounded to the nearest foot)}$$

Explore



Give each student a different object (paper clip, phone, book, index card, etc.) and tell them to measure the length of a desk or table using that object.

Guiding Questions

- What units did you use?
- How accurate was this method?
- Would it ever be practical to use your object to measure an object? When would it be practical and when would it not? Give examples.
- What was difficult about this? What was easy?

Explanation

Guiding Questions regarding scale

- What did the Eiffel Tower activity and the measuring activity have in common?
- What were the scale factors you used in the Eiffel Tower activity? The measuring activity?
- When do we use scale factors in our everyday lives? What is a scale factor?

Practice Together / in Small Groups / Individually



Students practice concepts of ratio and proportion involved in scale drawings by completing either the Scale Drawing Class Project or Scale Drawing Individual activity. These can be started in class and completed for homework.

Show students the scale drawing class project. Students can work on the scale drawing class project or on an individual scale drawing project. In either activity, students will be taking a small card and create a larger version to scale.

The Scale Drawing Individual Project was adapted with permission from the lesson Cartoons and Scale Drawings created by Sara Wheeler for the Alabama Learning Exchange. http://alex.state.al.us/lesson_view.php?id=26285 (See Notes)

INCLUDED IN THE STUDENT MANUAL

Task #8: Scale Drawing Class Project

Goal: To use scale drawing to recreate a card.

Project:

1. Find two identical greeting cards or make a copy of the original card.
2. Draw a 1 cm grid on the back of the original card.
3. Number each of the squares – this will be used to assemble the final project.
4. Cut the card into squares following the grid lines.
5. Place the cut squares into a container and chose one square, record which square you selected.
6. From the teacher, receive an 8" x 8" square of white paper.
7. Reproduce and color the square that you drew from the container onto the 8" x 8" sheet of paper using scale drawing.
8. Display the final drawing by placing the squares on a wall along with the original card.

Questions:

1. Look at the finished product and evaluate the display. Did the lines match up? Which part looks the best? Which piece would have been the easiest to recreate? The hardest? Why?
2. What is the relationship of the perimeter and area between your original square and the square you created? What is the relationship of the perimeter and area of the original square to the final class project?
3. If we did the project using 4" x 4" squares how would that have affected the perimeter and area?

INCLUDED IN THE STUDENT MANUAL

Task #9: Scale Drawing Individual

Goal: To select a card and enlarge it to best fit an 8 ½ “ x 11” sheet of paper.

To investigate how dimensions, perimeter and area are affected when doing scale drawings.

Please include in your project:

1. The original picture
2. The enlarged picture (colored to match original)
3. Measurements of the original picture
4. The scale selected to enlarge the picture
5. Self-Completed Evaluation

Design:

Step 1: Measure the length and width of the picture in cm. (It does not matter which side you label the length and width; be consistent with your sides on the large paper)

Length _____ Width _____

Step 2: Draw a 1 cm grid on the original card (Draw 1 cm tick marks going across the length and the width and then connect your marks to form a grid, these measurements need to be accurate)

Step 3: Measure the paper in cm.

Length _____ Width _____

Step 4: Select a scale (1 cm on card = _____ cm on paper)

- To do this find the ratio of lengths and widths

i.e.: $\frac{L_p}{L_c} = \frac{\quad}{\quad} = \frac{\quad}{\quad}$ $\frac{W_p}{W_c} = \frac{\quad}{\quad} = \frac{\quad}{\quad}$

- Then pick the smallest of the two numbers to the nearest whole number (i.e. if you get 4.29 and 4.76 your scale should be 1 cm card = 4 cm on paper)

Step 5: Draw the borders

- Multiply your length and width of the card by your scale factor and see how much of the paper you have left over for the border. Take this number and divide by two because the border should be on both sides.

i.e. $L_c \times \text{Scale Factor} = \underline{\quad}$ Then $(L_p - \underline{\quad})/2 = \underline{\quad}$
 $W_c \times \text{Scale Factor} = \underline{\quad}$ Then $(W_p - \underline{\quad})/2 = \underline{\quad}$

INCLUDED IN THE STUDENT MANUAL

Step 6: Draw a grid on your paper using your scale. (i.e. If your scale is 1:4, your grid on your large paper will be 4 cm x 4 cm; therefore, you would draw 4 cm tick marks going across the length and width and then connect your marks to form a grid.)

Step 7: Reconstruct drawing and color accordingly. Erase your grid marks on your final product before submitting the project! Colors, shading, and drawing should look identical!

1. What is the length and width of the squares of the small graph?

Length = _____ Width = _____

2. What is the length and width of the squares of the large graph?

Length = _____ Width = _____

3. What is the perimeter and area of each square on the small graph?

Perimeter = _____ Area = _____

4. What is the perimeter and area of each square on the large graph?

Perimeter = _____ Area = _____

5. How do the lengths of the small and large squares compare (answer as a fraction)?

Answer: _____

6. How do the widths of the small and large squares compare (answer as a fraction)?

Answer: _____

7. How do the perimeters compare (answer as a fraction)?

Answer: _____

8. How do the areas compare (answer as a fraction)?

Answer: _____

INCLUDED IN THE STUDENT MANUAL

9. What is the length and width of the original card?

Length = _____ Width = _____

10. What is the length and width of the enlarged card?

Length = _____ Width = _____

11. What is the perimeter of the original card?

Perimeter = _____

12. What is the perimeter of the enlarged card?

Perimeter = _____

13. How do the two perimeters compare (answer as a fraction)?

Answer: _____

14. What is the area of the original card?

Area: _____

15. What is the area of the enlarged card?

Area: _____

16. How do the two areas compare (answer as a fraction)?

Answer: _____

17. Are the comparisons for perimeter and area the same? Explain why you think this happened.

Yes or No

Evaluate Understanding

Multiple problems involving the concepts of ratio, proportion, scale and units can be found on pages 4-10 at the following url: <http://www.ohs.osceola.k12.fl.us/staff/websites/pettettl/documents/GeometrySCALEDRAWINGSpp.174-180.pdf>.

These problems reflect the content and format found in multiple national standardized tests. Completion of these problems will allow the student and teacher to assess their ability to transfer the knowledge acquired in the previous scale drawings to assessment items typically found on standardized math assessments. The problems included range in depth of knowledge providing students exposure to varying degrees of rigor.

INCLUDED IN THE STUDENT MANUAL

Scale Drawing Project Rubric

NOTE: When you submit your project, you will first score yourself using this rubric. Be honest and thorough in your evaluation. Remember to include the following parts in your presentation:

1. The original picture
2. The enlarged picture (colored to match original)
3. Measurements of the original picture
4. The scale selected to enlarge the picture
5. Self-Completed Evaluation

	10 – 9	8 – 7	6 – 5	4 – 0
Scale	All calculations and proportions are shown.	Most calculations and proportions are shown.	Few calculations and proportions are shown.	No calculations and proportions are shown.
Grids	All grid lines can be seen on card (grid lines on enlarged picture should be erased, but should appear faintly). All lines are parallel and measured correctly.	Most grid lines can be seen on card (grid lines on enlarged picture should be erased, but should appear faintly). Most lines are parallel and measured correctly.	Few grid lines can be seen on card (grid lines on enlarged picture should be erased, but should appear faintly). Few lines are parallel and measured correctly.	No grid lines can be seen on card (grid lines on enlarged picture should be erased, but should appear faintly). No lines are parallel, nor measured correctly.
Reconstruction	All proportions are accurate on the enlarged picture.	Most proportions are accurate on the enlarged picture.	Few proportions are accurate on the enlarged picture.	No proportions are accurate on the enlarged picture.
Presentation	The enlarged picture is colored neatly in the lines and colors match original card.	Most of the enlarged picture is colored neatly in the lines and most of the colors match original card.	Some of the enlarged picture is colored neatly in the lines and some of the colors match original card.	The enlarged picture is not colored neatly in the lines and does not match original card.

Total Points Possible: 40

Self-Assessment:

Scale: _____/10
 Grids: _____/10
 Reconstruction: _____/10
 Presentation: _____/10
 Total Points: _____/40

Teacher-Assessment:

Scale: _____/10
 Grids: _____/10
 Reconstruction: _____/10
 Presentation: _____/10
 Total Points: _____/40

Comment on your level of effort and accuracy on this project:

Teacher Comments:

Adapted from the lesson Cartoons and Scale Drawings created by Sara Wheeler for the Alabama Learning Exchange. http://alex.state.al.us/lesson_view.php?id=26285

Closing Activity

Students will continue working on the Scale Drawing activity.

Independent Practice:

Students will complete the Scale Drawing activity as homework.

Resources/Instructional Materials Needed:

- Rulers, paper, pencils, random items in a classroom (paper clip, phone, book, etc.)

Notes:

Measurement and Proportional Reasoning

Lesson 5 of 8

Area and Perimeter

Description:

This lesson asks students to look at area and perimeter, solving problems involving maximizing or minimizing area. Students begin a multiple day immersion into the conceptual and applied use of area and perimeter.

Georgia Standards of Excellence Addressed:

- MGSE9-12.G.MG.3: Apply geometric methods to solve design problems (e.g., designing an object or structure to satisfy physical constraints or minimize cost; working with typographic grid systems based on ratios).

Standard(s) for Mathematical Practice Emphasized:

- SMP 1: Make sense of problems and persevere in solving them.
- SMP 3: Construct viable arguments and critique the reasoning of others.
- SMP 4: Model with mathematics.
- SMP 6: Attend to precision.

Sequence of
Instruction

Activities Checklist

Explore



Is It Really Twice?



Elicit discussion from students regarding advertisements such as the one shown in the image above. Is the claim that this 80" LED Smart TV contains more than double the screen area of a 55" class TV true? This will open up opportunities to discuss how various applications have specific measurement methods.

Given the picture in the link above, exactly how much more area does the 80" TV have than the 55" TV? (The ratio of length to height is 16:9.) What is the area of each of the TVs?

- Rather than providing the students with the handout, the teacher may provide students with time and opportunity to work in groups to determine the answers to the questions above. Then use the questions on the handout to guide discussion.
- Handouts are available for Task #10: Comparing TV Areas.

The image above was taken found at <http://www.101qs.com/960-costco-tv>.

INCLUDED IN THE STUDENT MANUAL

Task #10: Comparing TV Areas

Does an 80" TV Really Have More Than Twice the Area of a 55" TV?



1. What does the 80 inches represent in an 80" TV?
2. Find the area of an 80" TV if the ratio of the length to the height is 16:9.
3. Find the area of a 55" TV. The ratio of the length to the height is the same.
4. How much more area does the 80" TV have than the 55" TV?
5. Is the advertisement accurate?

Comparing TV Areas Solution

1. The length of the diagonal.
2. Find the area of an 80" TV if the ratio of the length to the height is 16:9.

$$L^2 + (0.5625 L)^2 = 80^2$$

$$L^2 + 0.31640625 L^2 = 6400$$

$$1.31640625 L^2 = 6400$$

$$L^2 = 4861.721068$$

$$L = 69.726 \text{ in}$$

$$W = 39.221 \text{ in}$$

$$\text{Area} = 2734.72 \text{ in}^2$$

$$L/W = 16/9$$

$$16W = 9L$$

$$W = 0.5625 L$$

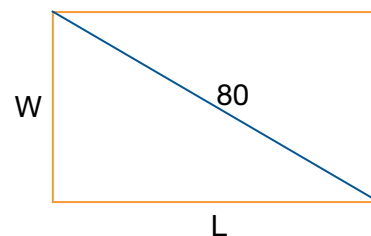

3. Find the area of a 55" TV. The ratio of the length to the height is the same.

$$L^2 + (0.5625 L)^2 = 55^2$$

$$L^2 + 0.31640625 L^2 = 3025$$

$$1.31640625 L^2 = 3025$$

$$L^2 = 2297.922849$$

$$L = 47.937 \text{ in}$$

$$W = 26.965 \text{ in}$$

$$\text{Area} = 1292.62 \text{ in}^2$$

$$L/W = 16/9$$

$$16W = 9L$$

$$W = 0.5625 L$$

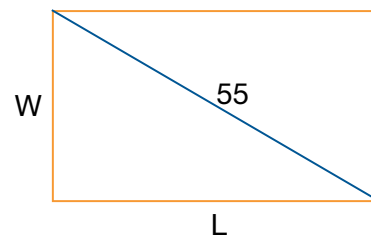

4. How much more area does the 80" TV have than the 55" TV?

$$2734.72 \text{ in}^2 - 1292.62 \text{ in}^2 = 1442.1 \text{ in}^2$$

The 80" TV has 1442.1 in² more area than the 55" TV.

5. Is the advertisement accurate?

$$2 (1292.62 \text{ in}^2) = 2585.24 \text{ in}^2$$

Yes, the area of the 80" TV is more than twice the area of the 55" TV.

Explanation

Guiding Questions

- Review area formulas of rectangles, squares, and triangles.
- What is the easiest way to determine the area of just the floor not covered by furniture?
- How do we determine the area of the floor covered by oddly shaped furniture?

Explore

Area of a Circle: Discuss the area formula for a circle given the following diagram. Provide students with paper plates and ask them to cut the plates into 8 equivalent sectors. Students will take each sector of the circle and place them end to end as shown below.

<http://mathworld.wolfram.com/Circle.html>

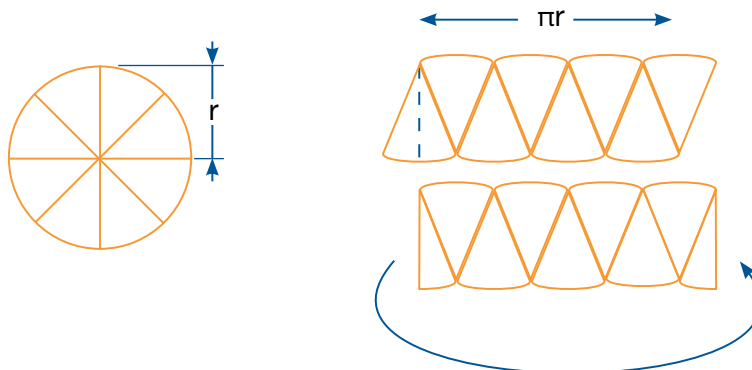

Remind students that the formula for the circumference of a circle is $2 * \pi * r$.

Guiding Questions

- A. What shape does this create?
- B. What is the length?
- C. What is the height?
- D. How do you find the area?
- E. How does this relate to the area of a circle?

<http://www.dpi.state.nc.us/docs/curriculum/mathematics/scos/7.pdf> (p. 28)

Practice Together / in Small Groups / Individually



INCLUDED IN THE STUDENT MANUAL

Task #11: Area and Perimeter of Irregular Shapes

Find the area and perimeter of each of the following shapes.

1. Perimeter = _____
 Area = _____

2. Perimeter = _____
 Area = _____

3. Perimeter = _____
 Area = _____

4. Perimeter = _____
 Area = _____

5. Perimeter = _____
 Area = _____

(<http://freemathresource.com/lessons/general-math/91-areas-of-complex-shapes>)

Area and Perimeter of Irregular Shapes - Solutions

Note to Teacher: There are multiple ways to compute the results. Ask students if someone did it a different way and have them explain.

- Perimeter = $7+4+0.5+3+5+3+2.5+4 = 29$ ft
 Area = $7(4) + 5(3) = 43$ ft²
- Perimeter = $6(6) + 2(12) = 36 + 24 = 60$ mm
 Area = $2 [6(12)] = 144$ mm²
- Perimeter = $6+10+11+6+5+4 = 42$ m
 Area = $6(10) + 5(6) = 90$ m²
- Perimeter = $8 + 3\sqrt{2} + 4 + 14 + 4 + 3\sqrt{2}$
 $= 30 + 6\sqrt{2}$ in ≈ 38.48 in
 Area = $\frac{1}{2} (8 + 14) (3)+4(14) = 33 + 56 = 89$ in²
 $x_2 = 3^2 + 3^2 = 9 + 9 = 18$
 $x = \sqrt{18} = 3\sqrt{2} \approx 4.24$
- Perimeter = $15+6+6+5+ \sqrt{130} +16+20$
 $= 68 + \sqrt{130}$ m ≈ 79.4 m
 Area = $6(6) + 9(20) + \frac{1}{2} (7)(9) = 247.5$ m₂
 $x^2 = 9^2 + 7^2 = 81 + 49 = 130$
 $x = \sqrt{130} \approx 11.4$

The next three problems are on the Area Problems activity. Students should work together in groups of 2 or 3. As the students are working, the teacher should circulate the room guiding struggling groups. At the same time, the teacher should be making note of the ways students are approaching the problems, especially those who approach the problems differently but arrive at a correct answer.

INCLUDED IN THE STUDENT MANUAL

Task #12: Area Problems

Find the area and perimeter of each of the following shapes.

- Find the largest possible rectangular area you can enclose with 96 meters of fencing. What is the (geometric) significance of the dimensions of this largest possible enclosure? What are the dimensions in meters? What are the dimensions in feet? What is the area in square feet?

- The riding stables just received an unexpected rush of registrations for the next horse show, and quickly needs to create some additional paddock space. There is sufficient funding to rent 1200 feet of temporary chain-link fencing. The plan is to form two paddocks with one shared fence running down the middle. What is the maximum area that the stables can obtain, and what are the dimensions of each of the two paddocks?

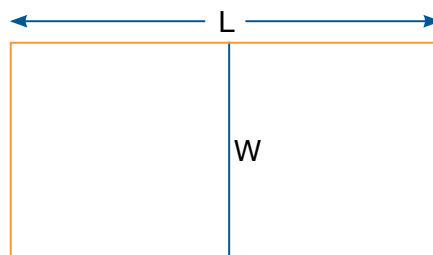

3. A farmer has a square field that measures 100 m on a side. He wants to irrigate as much of the field as he possibly can using a circular irrigation system.

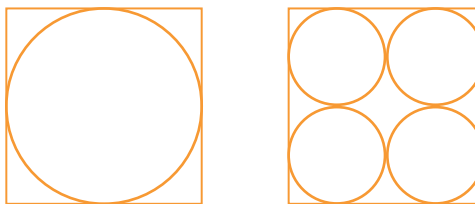

- Predict which irrigation system will irrigate more land?
- What percent of the field will be irrigated by the large system?
- What percent of the field will be irrigated by the four smaller systems?
- Which system will irrigate more land?
- What generalization can you draw from your answers?

Source: purplemath.com/modules/perimetr6.htm

Area Problems Solutions

1. The largest area comes from a square.

The dimensions are 24 m by 24 m.

The area is 576 m^2 .

$24 \text{ m} \times 39.37 \text{ in}/1 \text{ m} \times 1 \text{ ft}/12 \text{ in} = 78.74 \text{ ft}$

The dimensions are 78.74 ft by 78.74 ft.

The area is 6199.99 ft^2 .

2. $A = wL$

$$A = w(600 - 3/2 w)$$

$$2L + 3w = 1200$$

$$A = 600w - 3/2 w^2$$

$$2L = 1200 - 3w$$

Maximum area occurs when $w=200$

$$L = 600 - 3/2 w$$

$$L = 600 - 3/2 (200) = 300$$

Each paddock is 200 ft by 150 ft.

3. A farmer has a square field that measures 100 m on a side. He wants to irrigate as much of the field as he possibly can using a circular irrigation system.

- a. Predict which irrigation system will irrigate more land.

b. Area of field = $100 \text{ m} \times 100 \text{ m} = 10,000 \text{ m}^2$

Area covered by large system = $\pi(50)^2 = 2500\pi \approx 7853.98 \text{ m}^2$

Percent coverage = $7853.98/10,000 = .785398 \approx 78.54\%$

c. Area covered by small systems = $4[\pi(25)^2] = 2500\pi \approx 7853.98 \text{ m}^2$

Percent coverage = $7853.98/10,000 = .785398 \approx 78.54\%$

- d. They both cover the same amount.

- e. Any system of circular irrigation where the circles are tangent and congruent will cover that same percentage of the field.

INCLUDED IN THE STUDENT MANUAL

Task #15: Area & Perimeter Exit Slip

DIRECTIONS: Calculate the perimeter and the area of each rectangle.

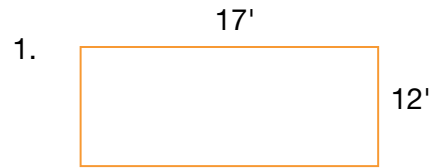

Perimeter = _____

Area = _____



Perimeter = _____

Area = _____

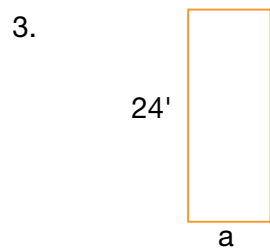

Perimeter = _____

Area = _____

4. A rectangle has an area of 2,130' and a width of 30', find its length and perimeter.

5. The perimeter of the triangle below is 52 cm. Find the length of each side of the triangle. Show your calculations.

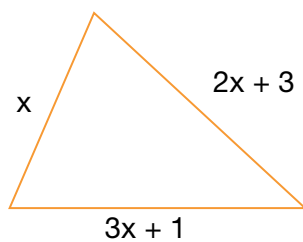

Measurement and Proportional Reasoning

Lesson 6 of 8

Optional Project Lesson: Maximizing Area and Perimeter

Description:

Students will continue to look at area and perimeter, solving problems involving maximizing or minimizing area. This is the continuation of the multiple day immersion into the conceptual and applied use of area and perimeter. In this lesson, students will use features of their graphing calculators to examine how area can be maximized.

Georgia Standards of Excellence Addressed:

- MGSE9-12.G.MG.3: Apply geometric methods to solve design problems (e.g., designing an object or structure to satisfy physical constraints or minimize cost; working with typographic grid systems based on ratios).

Standard(s) for Mathematical Practice Emphasized:

- SMP 1: Make sense of problems and persevere in solving them.
- SMP 3: Construct viable arguments and critique the reasoning of others.
- SMP 4: Model with mathematics.
- SMP 6: Attend to precision.

Sequence of Instruction	Activities Checklist
	<p>During this optional, multi-day lesson, students will work with group members or partners to determine whether or not area can change and perimeter remain the same, while strengthening their understanding of area and perimeter. In conclusion they will determine the shape which will always maximize area.</p> <p>Pen for Penny: http://www.nsa.gov/academia/_files/collected_learning/high_school/geometry/pen_for_penny.pdf.</p> <p>Permission for use at http://www.nsa.gov/academia/early_opportunities/math_edu_partnership/collected_learning/.</p>

Day One:

Students will complete the warm-up activity (Day 1 warm-up) to reinforce the idea of area being multiplication and perimeter being addition. A group manipulative activity (Activity 1) will also be completed.

Day Two:

Students will complete a warm-up (Day 2 warm-up) to recall yesterday's lesson. At this point the teacher will introduce and give instructions for problem #1.

Day Three:

Students will need to complete problem #2 and #3. (Teacher must give instruction for graphing calculator use for problem #'s 2 and 3.) Warm-ups and templates for manipulatives and activity sheets are provided.

INCLUDED IN THE STUDENT MANUAL

Assumption Fact Sheet

Your family has just purchased a new home. Your property is located in a high traffic area. You need to build a pet pen to protect "Penny," who is very playful. Although Penny is a good dog she must be protected and placed in a pen. The pen needs to be designed to give her the largest area possible to roam freely.

Use the information below that you feel is needed to solve the problem:

- Your house is 28' x 42'.
- Penny loves to play frisbee.
- Penny's pen must be rectangular.
- Your house has 4 bedrooms and 3 bathrooms.
- You can only afford 40' of fencing.
- Your plot of land is 124' x 212'.
- Your house must be 40' from Apple Avenue which is parallel to the front of your house.
- Penny likes to eat steak.
- The fencing is 5' in height.
- Penny is eight years old.
- Your house is 52' away from Cobbler Court and there is 30' of yard on the other side of the house.
- Cobbler Court is perpendicular to Apple Avenue.
- Your house is located on a rectangular corner lot at the intersection of Cobbler Court and Apple Avenue.
- After living in the house for a few months, your family builds a 30' x 15' garage on your house (problem #3 only).

Your Property (for problem #1)

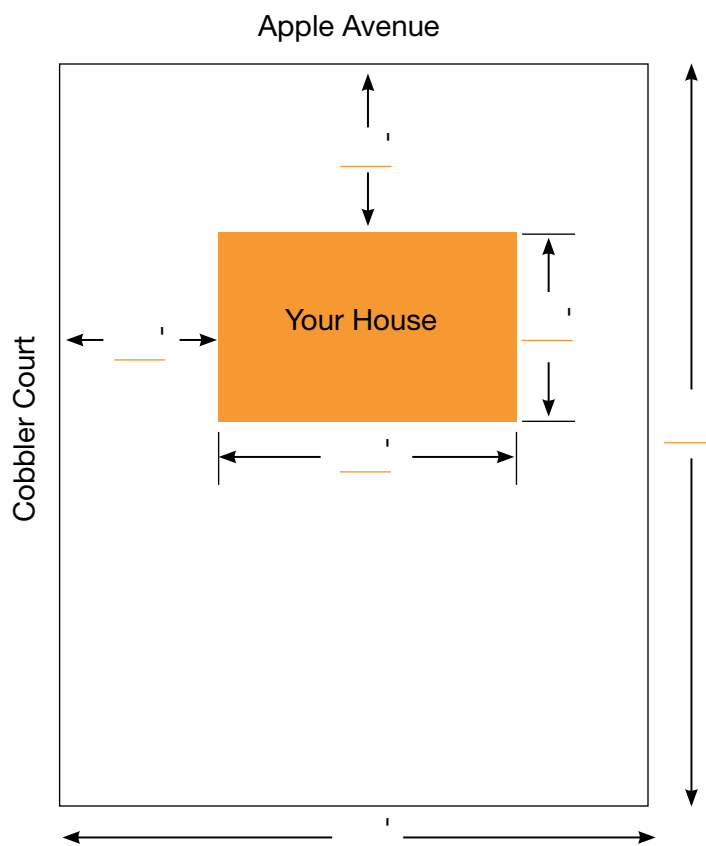

Problem 1

Given the dimensions of your property, your task is to build an isolated pen (away from the house) for Penny behind your house. You want to have the largest possible area for the pen to provide Penny room to roam freely. Write the data numbers in the spaces above and sketch or draw Penny's pen on your property. (Remember to label all measurements.)

1. List the assumptions that are most relevant in determining the dimensions of Penny's pen.

2. Fill in the table below and find a pattern to determine the most suitable dimensions for Penny's pen.

[A]	[B]	[C]	[D]	[E]	[F]
[Input]	$2 \times [A]$	$40 - [B]$	$[C] / 2$	$[B] + [C]$	$[A] \times [D]$
LENGTH	$2 \times \text{LENGTH}$	$2 \times \text{WIDTH}$	WIDTH	PERIMETER	AREA

3. Based on above findings, what is the maximum area that Penny's pen can be?

a) _____

b) Explain.

c) What geometric shape is Penny's pen?

4. Use your straightedge to draw Penny's pen on your property.

5. With your teacher, you will now construct the table you have created above on a graphing calculator. See Addendum 1 for detailed instructions.

Your Property (for problem #2)

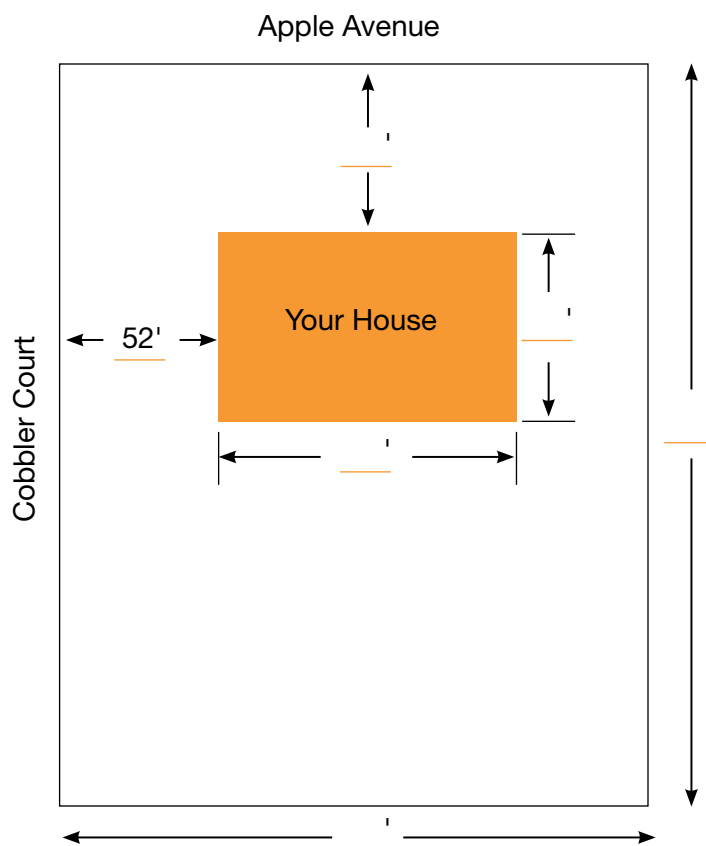

Problem 2

Your next task is to design a pen for Penny which is not necessarily isolated (away from the house). You still want to maximize the area. (Remember to label all measurements and make a new sketch.)

1. List the assumptions that are most relevant in determining the dimensions of Penny's pen (at least one should be different from those you listed in Problem #1).

2. With your partner, design a table using a graphing calculator to solve the problem. Your table should make use of formulas to calculate data. When the table is complete, copy your column headings (the headings you would use if you were writing on paper), formulas, and the line of data which contains the maximum area in the table below.

Graph Calc Headings	L1	L2	L3	L4	L5	L6
Column Headings						
Formulas						
Maximum Area						

3. Based on the table you built, what is the new maximum area that Penny's pen can be?

a) _____

b) Explain.

c) What geometric shape is Penny's pen?

4. Use your straightedge to draw Penny's pen on your property.

5. With your teacher, you will now construct the table you have created above on a graphing calculator.

Your Property with Garage (for problem #3)

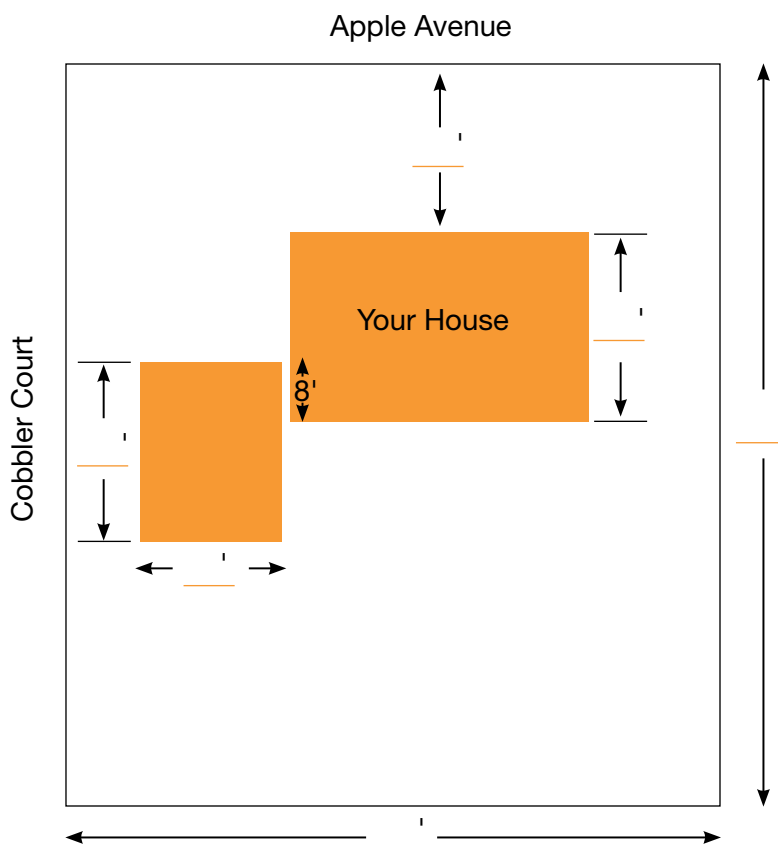

Problem 3

Your final task is to build a different pen for Penny. Remember you only have 40 feet of fencing to work with and you still want to have the largest possible area. Remember to label all measurements. (Hint: Your pen should not be isolated away from the house.)

1. List the assumptions that are most relevant in determining the dimensions of Penny's pen (at least one should be different from those you listed in Problem #2).

2. With your partner, design a table using a graphing calculator to solve the problem. Your table should make use of formulas to calculate data. When the table is complete, copy your column headings (the headings you would use if you were writing on paper), formulas, and the line of data which contains the maximum area in the table below.

Graph Calc Headings	L1	L2	L3	L4	L5	L6
Column Headings						
Formulas						
Maximum Area						

3. Based on the table you built, what is the new maximum area that Penny’s pen can be?

a) _____

b) Explain.

c) What geometric shape is Penny’s pen?

4. Use your straightedge to draw Penny’s pen on your property.

5. What geometric shape were two of the three pens you designed for Penny?

a) _____

b) Can you draw a conclusion about maximizing area while keeping perimeter constant? Write your conclusion in complete sentences.

Addendum 1

Instructions for use of graphing calculator

You will now use the graphing calculator to build the table you used in Problem #1. You will find that it does many of your tedious calculations for you.

Note: Words in uppercase letters represent a button on your calculator.

1. Press STAT, then 1. You should now see columns across your screen, labeled L1, L2, etc.

Record the column headings from your table in order below:

L1:
L2:
L3:
L4:
L5:
L6:

2. If there is data in your columns you need to clear it out. Arrow up to the heading (L1) and press CLEAR. Then arrow down one or two spaces. The column should now appear empty. Do this to clear all your columns.
3. Enter the data in your first column under L1 (this should represent “length”) by using the number keys and the arrow keys.
4. Now that your numbers are entered you need to write the formulas which will calculate the rest of the data in your table. Arrow up and put your cursor over the heading L2.
5. The L2 column will calculate $2 * \text{length}$ (remember that length is in column L1). You will enter the formula $2 * L1$ by following these keystrokes: 2 ; X ; 2ND ; 1 (this will enter L1 in your calculator) ; ENTER
Column L2 should now have numbers in it. They should be double the numbers you entered in column L1.
5. Now arrow over to column L4 (we will go back to L3 next) and move your cursor over the heading L4. This column represents $2 * \text{width}$. A formula you could use to calculate this column is: $40 - (2 * \text{length})$. Remember, $(2 * \text{length})$ is already calculated in L2 so our formula will be: $40 - L2$.
It should be entered into the calculator using the following keystrokes: 40 ; - ; 2nd ; 2 (this will enter L2); ENTER
6. Arrow back over to the L3 column heading. This column represents width. How do you think you will write the formula for this column?

-
7. A formula you could use is: $(2 * \text{width}) / 2$ so this will be entered by following these keystrokes: 2nd ; 4 ; Divide ; 2 ; ENTER.

Measurement and Proportional Reasoning

Lesson 7 of 8

Coordinate Connections

Description:

Students will use coordinates to prove simple geometric theorems and to explain some geometric formulas.

Georgia Standards of Excellence Addressed:

- MGSE9-12.G.GPE.4: Use coordinates to prove simple geometric theorems algebraically. For example, prove or disprove that a figure defined by four given points in the coordinate plane is a rectangle; prove or disprove that the point $(1, \sqrt{3})$ lies on the circle centered at the origin and containing the point $(0,2)$. (Focus on quadrilaterals, right triangles, and circles.)
- MGSE9-12.G.GPE.7: Use coordinates to compute perimeters of polygons and areas of triangles and rectangles, e.g., using the distance formula.

Standard(s) for Mathematical Practice Emphasized:

- SMP 2: Reason abstractly and quantitatively.
- SMP 3: Construct viable arguments and critique the reasoning of others.
- SMP 4: Model with mathematics.
- SMP 7: Look for and make use of structure.
- SMP 8: Look for and express regularity in repeated reasoning.

Sequence of
Instruction

Activities Checklist

Engage



Using graph paper, plot and label points $A(1, 3)$, $B(-3, 1)$, $C(-1, -3)$, and $D(3, -1)$. What shape do segments AB , BC , CD , and DA form?

- How did you know identify the shape? What characteristic did you use?
- Could this shape be classified in more than one way?
- What are its properties?

Note: Students may use software such as Geometer's Sketchpad or manipulatives such as geoboards in place of graph paper.

Explore



Discussion:

- Review the properties of parallelograms, rectangles, squares, and rhombi.
- How do you determine whether a quadrilateral is a parallelogram?
- A rectangle?
- A rhombus?
- A square?

Explanation

Review the distance formula, midpoint formula, and slope formula. Ask students to solve the following problems individually then share their answers. Lead students in discussions about the best way to approach the proofs.

Points $A(1, 3)$, $B(-3, 1)$, $C(-1, -3)$, $D(3, -1)$ form a square. (Have students work in groups to make a list of properties of a square. Then have each group prove and explain to the class one of the properties. See examples below.)

- Prove algebraically that all 4 sides are congruent.
- Prove algebraically that diagonals bisect each other.
- Prove algebraically that adjacent sides are perpendicular.
- Prove algebraically that opposite sides are parallel.
- Prove algebraically that diagonals are perpendicular.

Practice Together / in Small Groups / Individually

INCLUDED IN THE STUDENT MANUAL

Task #16: Quadrilateral Activity

1. Points $A(1, 3)$, $B(-3, 1)$, $C(-1, -3)$, $D(3, -1)$ form a square
 - a. Graph the points and connect them.

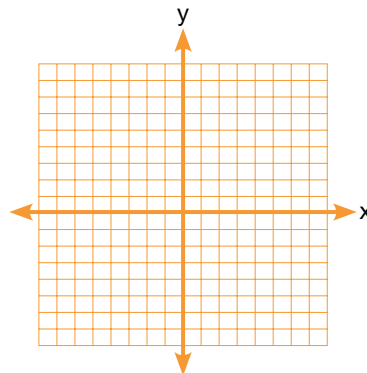

- b. List as many properties of a square as you can.
- c. Show algebraically that the property assigned to your group is true for this square and all squares.
- d. Find the area and perimeter of ABCD.

2. Consider the points $F(-4, -1)$, $G(-2, -5)$, $H(4, -2)$ and $J(2,2)$.
a. Graph the points.

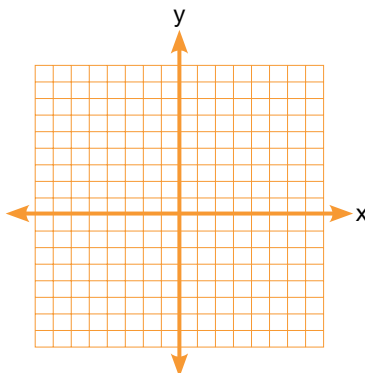

- b. What type of quadrilateral is $FGHJ$?

3. Consider the points $K(-2, -1)$, $L(-1, 2)$, $M(2, 4)$ and $N(1,1)$.
a. Graph the points.

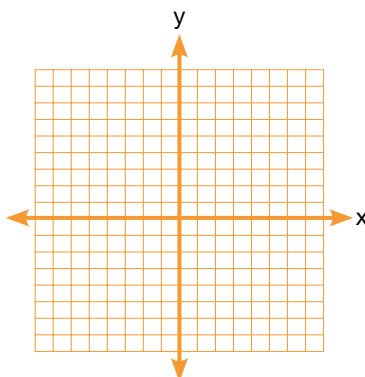

- b. What type of quadrilateral is $KLMN$? Show your work and justify your reasoning.

Quadrilateral Activity - Solutions

1. Points $A(1, 3)$, $B(-3, 1)$, $C(-1, -3)$, $D(3, -1)$ form a square
a. Graph the points and connect them.

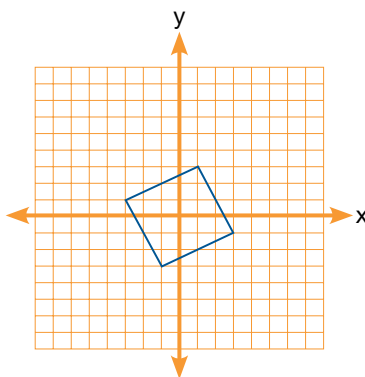

- b. List as many properties of a square as you can.
Lists may include:
All four sides are congruent.
Adjacent sides are perpendicular.

Opposite sides are parallel.
 The diagonals are perpendicular.
 The diagonals bisect each other.

c. Show algebraically that the property assigned to your group is true for this square.

2. Consider the points $F(-4, -1)$, $G(-2, -5)$, $H(4, -2)$ and $J(2, 2)$.

a. Graph the points.

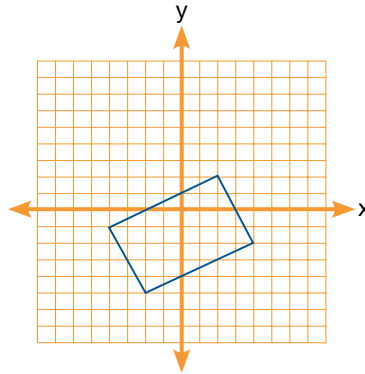

b. Determine if $FGHJ$ is a rectangle. Show your work and justify your reasoning.

It is a rectangle.

3. Consider the points $K(-2, -1)$, $L(-1, 2)$, $M(2, 4)$ and $N(1, 1)$.

a. Graph the points.

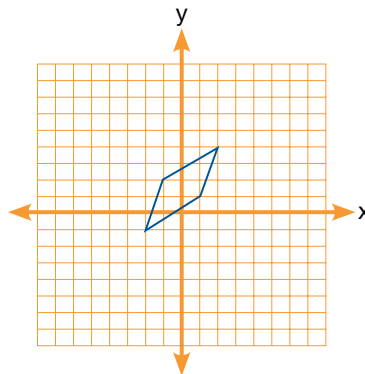

b. What type of quadrilateral is $KLMN$? Show your work and justify your reasoning.

$KLMN$ is a parallelogram.

Evaluate Understanding



Given that the figure below is a rectangle,

- Find the coordinates of the other 2 vertices.
- Prove algebraically that 2 adjacent segments are perpendicular
- Prove algebraically that the diagonals bisect each other.
- Is this a square? How do you know?

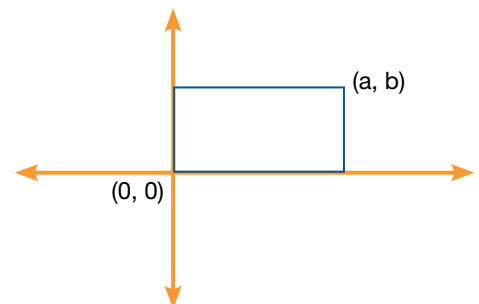

Measurement and Proportional Reasoning

Lesson 8 of 8

Formative Assessment Lesson: Evaluating Statements About Enlargements (2D & 3D)

Description:

This lesson is intended to help the student and teacher assess how well students are able to conceptualize and solve problems involving area and volume. In particular, the lesson is used to help identify and assist students who have difficulties with the following:

- Computing perimeters, areas and volumes using formulas.
- Finding the relationships between perimeters, areas, and volumes of shapes after scaling.

Georgia Standards of Excellence Addressed:

- MGSE9-12.G.GMD.1: Give informal arguments for geometric formulas.
 - a. Give informal arguments for the formulas of the circumference of a circle and area of a circle using dissection arguments and informal limit arguments.
 - b. Give informal arguments for the formula of the volume of a cylinder, pyramid and cone using Cavalieri's principle.
- MGSE9-12.G.GMD.3: Use volume formulas for cylinders, pyramids, cones, and spheres to solve problems.

Standard(s) for Mathematical Practice Emphasized:

- SMP 3: Construct viable arguments and critique the reasoning of others.
- SMP 7: Look for and make use of structure.

The following *Formative Assessment Lesson* is a classroom-ready lesson included to help teachers assess and improve students' understanding of mathematical concepts and skills and their ability to use the "mathematical practices" described in the College Readiness Standards.

Research has shown that formative assessment, as embodied in the following lesson, is a powerful way to improve student learning and performance. This approach first allows students to demonstrate their prior understandings and abilities in employing the mathematical processes, and then resolve their own difficulties and misconceptions through structured discussion. This results in more secure long-term learning, reducing the need for re-teaching that otherwise takes so much classroom time.

Many often ask, why don't students just remember the procedures they have been taught and practiced? The fact is, that approach works fine in the short term but, as every teacher knows, if procedural knowledge is not underpinned by conceptual understanding, students will quickly forget "how to do it."

Read more about the *Formative Assessment Lesson* rationale, structure, and philosophy using the *Brief Guide for Teachers and Administrators* that can be found at <http://map.mathshell.org/materials/index.php>.

CONCEPT DEVELOPMENT

Mathematics Assessment Project
CLASSROOM CHALLENGES
A Formative Assessment Lesson

Evaluating Statements about Enlargements (2D & 3D)

Mathematics Assessment Resource Service
University of Nottingham & UC Berkeley
Beta Version

For more details, visit: <http://map.mathshell.org>
© 2012 MARS, Shell Center, University of Nottingham
May be reproduced, unmodified, for non-commercial purposes under the Creative Commons license
detailed at <http://creativecommons.org/licenses/by-nc-nd/3.0/> - all other rights reserved

BEFORE THE LESSON

Assessment task: A Fair Price (15 minutes)

Set this task, in class or for homework, a few days before the formative assessment lesson. This will give you an opportunity to assess the work to find out the kinds of difficulties students have with it. Then you will be able to target your help more effectively in the follow-up lesson.

Give each student a copy of *A Fair Price*.

A Fair Price

In the following questions, *fair price* means that the amount you get is in proportion to the amount you pay. For example, the fair price for twelve cookies is double the cost of six.

You may find the following formulae useful.



Area of a circle: πr^2
Circumference of circle: $2\pi r$

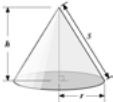

Volume of a cone: $\frac{1}{3}\pi r^2 h$

1. Candy Rings

A large ring of candy has a diameter of 8 inches, and a small ring has a diameter of 4 inches.



(Diagram not to scale.)
Jasmina says:

"I get the same amount of candy from two small rings as from one large ring."

1. Is Jasmina correct? If you think Jasmina is correct explain why. If you think she is incorrect, replace the statement with one that is correct. Explain why your statement is correct.

.....

.....

.....

.....

.....

.....

.....

.....

.....

.....

If the price of the small ring of candy is 40 cents, what is a *fair price* for a large one? Explain your answer.

.....

.....

.....

.....

.....

2. Pizzas

A large pizza has a diameter of 12 inches. A small pizza has a diameter of 6 inches.



(Diagram not to scale.)

"I get the same amount of pizza from three small pizzas as from one large pizza."

Is Jasmina correct about the pizzas?
If you think Jasmina is correct explain why.
If you think she is incorrect replace the statement with one that is correct. Explain why your statement is correct.

.....

.....

.....

.....

.....

.....

.....

.....

.....

.....

If the price for a small pizza is \$3, what is a *fair price* for a large one? Explain your answer.

.....

.....

.....

.....

.....

3. Popcorn

The larger cone has a top radius of 4 inches and a height of 12 inches.

The small cone has a top radius of 2 inches and a height of 6 inches.



(Diagram not to scale.)

"I get the same amount of popcorn from two small cones as from one large cone."

Is Jasmina correct about the popcorn cones?
If you think Jasmina is correct, explain why.
If you think she is incorrect, replace the statement with one that is correct. Explain why your statement is correct.

.....

.....

.....

.....

.....

.....

.....

.....

.....

.....

If the price for a small cone of popcorn is \$1.20, what is a *fair price* for a large one?

.....

.....

.....

.....

.....

Briefly introduce the task and help the class to understand the problems and their context.

Read through the questions and try to answer them as carefully as you can.

Show all your work so that I can understand your reasoning.

Explain to the students what 'fair price' means.

In the questions, the term 'a fair price' means that the amount you get should be in proportion to the amount you pay.

So for example, if a pound of cookies costs \$3, a fair price for two pounds will be \$6.

It is important that, as far as possible, students are allowed to answer the questions without your assistance.

Students should not worry too much if they cannot understand or do everything because, in the next lesson, they will engage in a similar task that should help them. Explain to students that by the end of the next lesson, they should expect to be able to answer questions such as these confidently. This is their goal.

Assessing students' responses

Collect students' responses to the task. Make some notes on what their work reveals about their current levels of understanding, and their different problem solving approaches.

We suggest that you do not score students' work. The research shows that this will be counterproductive, as it will encourage students to compare their scores, and will distract their attention from what they can do to improve their mathematics.

Instead, help students to make further progress by summarizing their difficulties as a series of questions. Some suggestions for these are given below. These have been drawn from common difficulties observed in trials of this unit.

We suggest that you write a list of your own questions, based on your students' work, using the ideas that follow. You may choose to write questions on each student's work. If you do not have time to do this, select a few questions that will be of help the majority of students. These can be written on the board at the end of the lesson.

Write a list of questions, applicable to your own class. If you have enough time, add appropriate questions to each piece of your students' work.

Common issues:	Suggested questions and prompts:
<p>Student assumes the diagrams are accurate representations</p> <p>For example: The student writes “I’ve counted the candy. The larger circle has more than twice the amount of candy that the smaller one has.”</p> <p>Or: The student writes “Three small pizzas fit into the large one.”</p>	<ul style="list-style-type: none"> • The pictures are not accurate. • How can you use math to check that your answer is accurate?
<p>Student fails to mention scale</p> <p>For example: The areas of the two pizzas are calculated but not the scale of increase.</p>	<ul style="list-style-type: none"> • How can you figure out the scale of increase in area/volume using your answers?
<p>Student focuses on non-mathematical issues</p> <p>For example: The student writes “It takes longer to make three small pizzas than one large one. The large one should cost \$8.”</p>	<ul style="list-style-type: none"> • Now consider a fair price from the point of view of the customer. • Are three small pizzas equivalent to one big one? How do you know?
<p>Student makes a technical error</p> <p>For example: The student substitutes the diameter into the formula instead of the radius.</p> <p>Or: The student makes a mistake when calculating an area or volume.</p>	<ul style="list-style-type: none"> • What does r in the formula represent? • Check your calculations.
<p>Student simply triples the price of the pizza or doubles the price of a cone of popcorn.</p>	<ul style="list-style-type: none"> • Do you really get three times as much pizza? • Do you really get twice as much popcorn?
<p>Student correctly answers all the questions</p> <p>Student needs an extension task.</p>	<ul style="list-style-type: none"> • If a pizza is made that has a diameter four times bigger (ten times/n times), what should its price be? How do you know? Can you use algebra to explain your answer? • If a cone of popcorn has a diameter and height four times bigger (ten times/n times), what should its price be? How do you decide? Can you use algebra to explain your answer?

SUGGESTED LESSON OUTLINE

If you have a short lesson or you find the lesson is progressing at a slower pace than anticipated, then you may want to spend two lessons on the tasks. We give suggestions on how to manage this below.

Whole-class introduction (10 minutes)

This introduction will provide students with a model about how they should work during the collaborative tasks. Give each student a mini-whiteboard, a pen, and an eraser. Use the projector resource *Enlarging Rectangles*.

Enlarging Rectangles

If you double the length and width of a rectangle
then
you double its perimeter.

If you double the length and width of a rectangle
then
you double its area.

Decide whether each statement is true or false.

Write a convincing explanation.

If you think a statement is false then replace it with a correct one.

After a few minutes ask two or three students for their answers. Encourage them to write their explanations on the board. If students are struggling to provide convincing arguments, you could ask the following questions:

Can you use a diagram to convince me? Show me.

How do you know for sure your answer is correct for all rectangles?

Can you use algebra to convince me? Show me.

If the area is not doubled, then what scaling is taking place? Why is this?

Students may find it easiest to start by considering specific examples.

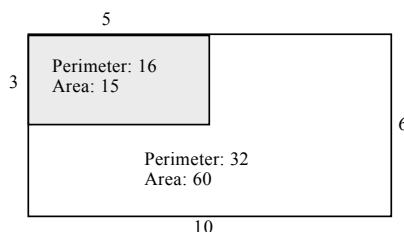

Encourage students to consider the statements more generally.

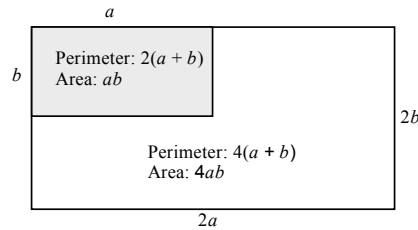

In this way, students may see that the first statement is true, but the second should be revised.

If you double the length and width of a rectangle, then you multiply its area by 4.

You may then want to look at different scale factors:

If the two measurements are multiplied by 3 instead of doubled what happens to the perimeter and area?

If the two measurements are increased by a scale factor of $10/n$, what happens to the area?

Collaborative activity: Scaling Up (20 minutes)

To introduce this task you may want to use the projector resource *3D Shapes*.

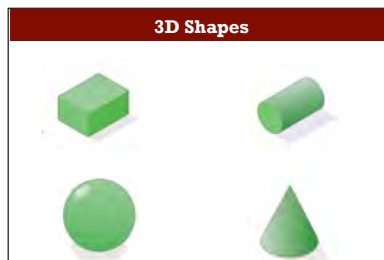

You could also show the class real examples of these 3D shapes.

Organize the students into groups of two or three.

Give each group the cut-up cards *Scaling Up*, a copy of the *Formula Sheet*, a large sheet of paper, and a glue stick.

The cards show rectangular prisms, circles, spheres, cylinders, and cones.

Sort the cards into these five different mathematical objects.

Your task is to decide whether each statement is true or false.

If you think a statement is false, change the second part of the statement to make it true.

Try to figure out what it is about the formula for the shape's area or volume that makes the statement true or false.

Show calculations, draw diagrams, and use algebra to convince yourself that you have made a correct decision.

When everyone in your group agrees with the decision for one object, place the statements on the poster and write your explanations around it.

Begin by working with the statements on rectangular prisms.

You may not have time to consider all twelve statements.

It is better for you to explain your reasoning fully for a few statements than to rush through trying to decide whether all the statements are true or false.

If you think your class will understand the notion of leaving π in the answer, then do not give out calculators as their use can prevent students noticing the factor of the increase.

You have two tasks during the small group work: to make a note of student approaches to the task, and to support student problem solving.

Make a note of student approaches to the task

Listen and watch students carefully. In particular, listen to see whether they are addressing the difficulties outlined in the *Common issues* table (above). You can use this information to focus a whole-class discussion towards the end of the lesson.

Support student problem solving

Try not to do the thinking for students, but rather help them to reason for themselves. Encourage students to engage with each others' explanations, and take responsibility for each others' understanding.

Judith, why do you think this statement is true/false?

James, do you agree with Judith? Can you put her explanation into your own words?

If students are struggling to get started on the task:

What formula can you use to check if the statement is correct? What values can you put into this formula?

If it is not twice as big, by what factor has the area/volume increased? How do you know?

At first, you may want to focus your questioning on the cards about rectangular prisms:

Are any of these statements true? What is it about the formula that makes the formula true?

What has the volume of the rectangular prism increased by for this statement? How does this increase relate to the formula?

Students often prefer to multiply out π . This means they may not notice the factor of increase.

Can you express these two areas/volumes for this statement as multiples of π ? How does this help?

Students often do not recognize the relationship between the formula and the factor of the increase.

Show me two statements that are correct. What has doubled in each formula? What has remained the same?

Show me two statements where the area or volume has increased by a factor of four. Look at the two formulas and figure out why the area(s)/volume(s) has increased by the same factor.

Show me two statements where just the radius is doubled but the factors of increase are different. Look at the two formulas and figure out why the area(s)/volume(s) has increased by a different factor?

When the radius/height of this shape is doubled, what variable will change in the formula? [E.g., r , r^2 , or h .] How does this affect the area/volume?

If a lot of students are struggling on the same issue you may want to hold a brief whole-class discussion.

Encourage students who work through the task more quickly to think about how they can explain the scaling in general terms. They may use algebra in their explanation, or simply highlight the properties of a formula that determine the scaling.

Can you use algebra to show you are correct? If the radius has a length of n , what is double its length? How can you use this in the formula?

Can you figure out if the statement is true or not just by looking at the formula? Why? Why not?

If students finish early, have them consider what happens if the phrase ‘multiply by 3’ replaces the word ‘double.’

Extending the activities over two lessons

You may decide to spread the work over two lessons. If so, ask students to stop working on the task 10 minutes before the end of the lesson.

Ask students to glue the cards that they have worked on to the large sheet of paper. Remind them that there should be an explanation accompanying each card. Students can then use a paperclip to attach any remaining cards to their posters.

Hold a short whole-class discussion. Ask a representative from each group to use their group poster to explain their thinking about one statement to the whole-class. Encourage the rest of the class to challenge their explanations, but avoid intervening too much yourself.

You can then re-start the lesson with more poster work or by sharing posters (immediately below), as you see fit.

Sharing posters (10 minutes)

When a group has completed all the statements about one object, ask the students to compare their reasoning with that of a neighboring group.

Check which answers are different.

A member of each group needs to explain their reasoning for these answers. If anything is unclear, ask for clarification.

Then together consider if you should change any of your answers.

It is important that everyone in both groups understands the math. You are responsible for each other's learning.

Whole-class discussion (20 minutes)

Discuss as a class how the structure of a formula determines the increase.

Find me a card where the statement is correct. How does the formula relate to an increase by a factor of two? Find me another. What do the formulas have in common?

Find me a card that uses a formula involving r^2 . Is the statement correct? Why?/Why not? By what factor has the area/volume increased? Is it the same increase for all cards that use r^2 ? Why/Why not?

Find me a card that uses a formula involving r^3 . Is the statement correct? Why?/Why not? By what factor has the volume increased?

Now try to extend some of these generalizations. Use the projector resource *Is it correct?*

Is it correct?	
1.	If you treble the length and width of a rectangle <i>then</i> the perimeter increases by a factor of 3.
2.	If you treble the length and width of a rectangle <i>then</i> the area increases by a factor of 6.
3.	If you treble the length, width and height of a rectangular prism <i>then</i> the volume increases by a factor of 9.

I want you to decide if any of these statements are true.

If you think a statement is not true, then change the last part of the statement to make it true.

Students may have difficulties making decisions without using specific dimensions. Encourage those students who progressed well in the lesson to think of a general explanation.

If the statement is correct, how do you know?

*If the statement is not correct, then what factor does the perimeter/area /volume increase by?
How do you know?*

How does the increase relate to the formula?

If all the dimensions increase by five/ten/n times what happens to the perimeter/area and volume?

Ask two or three students to explain their answer.

Some students will begin to see that for similar shapes the area scale factor is the square of the scale, i.e. 3^2 , 5^2 , 10^2 , or n^2 and the volume scale factor is the cube of the scale, i.e. 3^3 , 5^3 , 10^3 , or n^3 .

If you have time you may want to consider the same task but use a different shape, such as a circle, cylinder, or cone.

Improving individual solutions to the assessment task (10 minutes)

Return to the students their original assessment *Fair Price*, as well as a second blank copy of the task.

Look at your original responses and think about what you have learned this lesson.

Using what you have learned, try to improve your work.

If you have not added questions to individual pieces of work then write your list of questions on the board. Students are to select from this list only the questions they think are appropriate to their own work.

If you find you are running out of time, then you could set this task as homework.

SOLUTIONS

ASSESSMENT TASK: A FAIR PRICE

- Jasmina is correct: if the radius doubles so will the circumference. This is a linear relationship.
The scale factor is 2.
The circumference of the small candy ring is 4π .
The circumference of the large candy ring is 8π .
A fair price for the large candy ring is 80 cents, double the price of the small one.
- Jasmina is incorrect.
The area of a small pizza is 9π and that of a large one is 36π . The area of four small pizzas is equal to the area of one large pizza.
The areas of similar figures are related by the square of the scale factor: $2^2 = 4$.
A correct statement might be, "I get the same amount of pizza from four small ones as one large one."
A fair price for the large pizza would be \$12, or 4 times \$3.
- Jasmina is incorrect.
The volume of the small cone is 8π and that of the large cone is 64π . The scale factor of the radius and height is 2.
Volumes of similar figures are related by the cube of the scale factor: $2^3 = 8$.
A correct statement might be, "I get the same amount of popcorn from eight small ones as one large one."
A fair price would be $8 \times \$1.20 = \9.60 .

Collaborative activity: Scaling Up

Below are the general solutions obtained by reasoning algebraically. Students will also provide solutions using on specific value.

<p>1. "If you double just the width of a rectangular prism then you double its volume" is true.</p> <p>If the width is a, $V = alh$ If the width is $2a$, $V = 2alh$ An increase by a factor of 2.</p>	<p>2. "If you double just the width and height of a rectangular prism then you double its volume" is false.</p> <p>If the width is a and the height is b, $V = alb$ If the width is $2a$ and the height is $2b$, $V = 4alb$. An increase by a factor of 4.</p>
---	---

<p>3. “If you double the width, height, and length of a rectangular prism then you double its volume” is false.</p> <p>If the width is a, the length is b and the height is c,</p> $V = abc$ <p>If the width is $2a$, the length is $2b$ and the height is $2c$,</p> $V = 8abc.$ <p>An increase by a factor of 8.</p>	<p>4. “If you double the radius of a circle then you double its circumference” is true.</p> <p>If the radius is a, $C = 2\pi a$</p> <p>If the radius is $2a$, $C = 4\pi a$</p> <p>An increase by a factor of 2.</p>
<p>5. “If you double the radius of a circle then you double its area” is false.</p> <p>If the radius is a, $A = \pi a^2$</p> <p>If the radius is $2a$, $A = 4\pi a^2$</p> <p>An increase by a factor of 4.</p>	<p>6. “If you double the radius of a sphere then you double its surface area” is false.</p> <p>If the radius is a, $A = 4\pi a^2$</p> <p>If the radius is $2a$, $A = 16\pi a^2$</p> <p>An increase by a factor of 4.</p>
<p>7. “If you double the radius of a sphere then you double its volume” is false.</p> <p>If the radius is a, $V = \frac{4}{3}\pi a^3$</p> <p>If the radius is $2a$, $V = \frac{32}{3}\pi a^3$</p> <p>An increase by a factor of 8.</p>	<p>8. “If you double just the radius of a cylinder then you double its curved surface area” is true.</p> <p>If the radius is a, $A = 2\pi ah$</p> <p>If the radius is $2a$, $A = 4\pi ah$.</p> <p>An increase by a factor of 2.</p>
<p>9. “If you double just the height of a cylinder then you double its volume” is true.</p> <p>If the height is b, $V = \pi r^2 b$</p> <p>If the height is $2b$, $V = 2\pi r^2 b$</p> <p>An increase by a factor of 2.</p>	<p>10. “If you double both the radius and height of a cylinder then you double its volume” is false.</p> <p>If the radius is a and the height is b, $V = \pi a^2 b$</p> <p>If the radius is $2a$ and the height is $2b$, $V = 8\pi a^2 b$</p> <p>An increase by a factor of 8.</p>
<p>11. “If you double just the base radius of a cone then you double its volume” is false.</p> <p>If the base radius is a, $V = \frac{1}{3}\pi a^2 h$</p> <p>If the base radius is $2a$, $V = \frac{4}{3}\pi a^2 h$</p> <p>An increase by a factor of 4.</p>	<p>12. “If you double both the height and base radius of a cone then you double its volume” is false.</p> <p>If the base radius is a, and the height is b, $V = \frac{1}{3}\pi a^2 b$</p> <p>If the base radius is $2a$, and the height is $2b$, $V = \frac{8}{3}\pi a^2 b$</p> <p>An increase by a factor of 8.</p>

A Fair Price

In the following questions, 'fair price' means that the amount you get is in proportion to the amount you pay. For example, the 'fair price' for twelve cookies is double the cost of six.

You may find the following formulae useful.

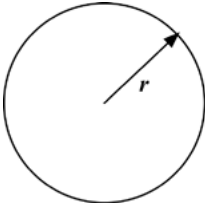
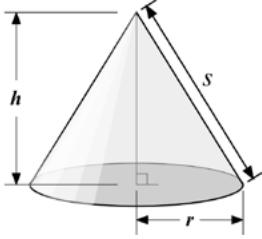
			
Area of a circle:	πr^2	Volume of a cone:	$\frac{1}{3}\pi r^2 h$
Circumference of circle:	$2\pi r$		

1. Candy Rings

A large ring of candy has a diameter of 8 inches, and a small ring has a diameter of 4 inches.



(Diagram not to scale.)
 Jasmina says:

"I get the same amount of candy from two small rings as from one large ring."

1. Is Jasmina correct? If you think Jasmina is correct explain why. If you think she is incorrect, replace the statement with one that is correct. Explain why your statement is correct.

.....

.....

.....

.....

.....

.....

If the price of the small ring of candy is 40 cents, what is a *fair price* for a large one? Explain your answer.

.....

.....

.....

.....

2. Pizzas

A large pizza has a diameter of 12 inches.
A small pizza has a diameter of 6 inches.



(Diagram not to scale.)

"I get the same amount of pizza from three small pizzas as from one large pizza."

Is Jasmina correct about the pizzas?

If you think Jasmina is correct explain why.

If you think she is incorrect replace the statement with one that is correct. Explain why your statement is correct.

.....

.....

.....

If the price for a small pizza is \$3, what is a 'fair price' for a large one?

Explain your answer.

.....

.....

.....

3. Popcorn

The larger cone has a top radius of 4 inches and a height of 12 inches.

The small cone has a top radius of 2 inches and a height of 6 inches.

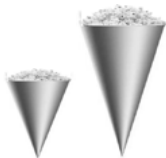

(Diagram not to scale.)

"I get the same amount of popcorn from two small cones as from one large cone."

Is Jasmina correct about the popcorn cones?

If you think Jasmina is correct, explain why.

If you think she is incorrect, replace the statement with one that is correct. Explain why your statement is correct.

.....

.....

.....

If the price for a small cone of popcorn is \$1.20, what is a 'fair price' for a large one?

.....

.....

.....

True or False?

<p>1. If you double just the width of a rectangular prism then you double its volume.</p>	<p>2. If you double just the width and height of a rectangular prism then you double its volume.</p>
<p>3. If you double the width, height, and length of a rectangular prism then you double its volume.</p>	<p>4. If you double the radius of a circle then you double its circumference.</p>
<p>5. If you double the radius of a circle then you double its area.</p>	<p>6. If you double the radius of a sphere then you double its surface area.</p>

True or False? (continued)

<p>7. If you double the radius of a sphere then you double its volume.</p>	<p>8. If you double just the radius of a cylinder then you double its curved surface area.</p>
<p>9. If you double just the height of a cylinder then you double its volume.</p>	<p>10. If you double both the radius and height of a cylinder then you double its volume</p>
<p>11. If you double just the base radius of a cone then you double its volume</p>	<p>12. If you double both the height and base radius of a cone then you double its volume.</p>

Formula Sheet

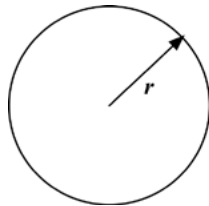

Area of a circle: πr^2
 Circumference of a circle: $2\pi r$

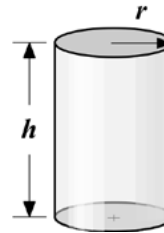

Volume of a cylinder: $\pi r^2 h$
 Curved surface area of a cylinder: $2\pi r h$

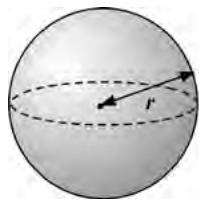

Volume of a sphere: $\frac{4}{3}\pi r^3$
 Surface area of a sphere: $4\pi r^2$

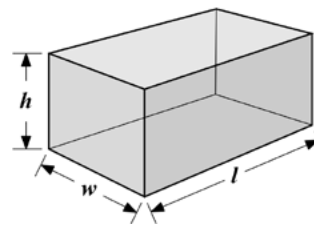

Volume of a right rectangular prism: lwh
 Surface area of a right rectangular prism: $2(lw + lh + wh)$

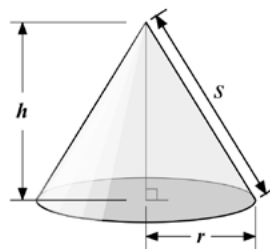

Volume of a cone: $\frac{1}{3}\pi r^2 h$
 Curved surface area of a cone: $\pi r s$

Enlarging Rectangles

If you double the length and width of a rectangle
then
you double its perimeter.

If you double the length and width of a rectangle
then
you double its area.

3D Shapes



Projector Resources

Evaluating Statements about Enlargements (2D & 3D)

P-2

True or False?

- If you think a statement is false, change the second part of the statement to make it true.
- Try to figure out what it is about the formula for the shape's area or volume that makes the statement true or false.
- Show calculations, draw diagrams, and use algebra to convince yourself that you have made a correct decision.
- When everyone in your group agrees with the decision for one object, place the statements on the poster and write your explanations around it.
- Begin by working with the statements on rectangular prisms.

Is it correct?

1.
If you treble the length and width of a rectangle
then
the perimeter increases by a factor of 3.
2.
If you treble the length and width of a rectangle
then
the area increases by a factor of 6.
3.
If you treble the length, width and height of a rectangular prism
then
the volume increases by a factor of 9.

Mathematics Assessment Project
CLASSROOM CHALLENGES

This lesson was designed and developed by the
Shell Center Team
at the
University of Nottingham
Malcolm Swan, Nichola Clarke, Clare Dawson, Sheila Evans
with
Hugh Burkhardt, Rita Crust, Andy Noyes, and Daniel Pead

It was refined on the basis of reports from teams of observers led by
David Foster, Mary Bouck, and Diane Schaefer
based on their observation of trials in US classrooms
along with comments from teachers and other users.

This project was conceived and directed for
MARS: Mathematics Assessment Resource Service
by
Alan Schoenfeld, Hugh Burkhardt, Daniel Pead, and Malcolm Swan
and based at the University of California, Berkeley

We are grateful to the many teachers, in the UK and the US, who trialed earlier versions
of these materials in their classrooms, to their students, and to
Judith Mills, Carol Hill, and Alvaro Villanueva who contributed to the design.

This development would not have been possible without the support of
Bill & Melinda Gates Foundation
We are particularly grateful to
Carina Wong, Melissa Chabran, and Jamie McKee

© 2012 MARS, Shell Center, University of Nottingham
This material may be reproduced and distributed, without modification, for non-commercial purposes,
under the Creative Commons License detailed at <http://creativecommons.org/licenses/by-nc-nd/3.0/>
All other rights reserved.
Please contact map.info@mathshell.org if this license does not meet your needs.

SREB Readiness Courses
Transitioning to college and careers

Math Ready

Unit 3 . Measurement
and Proportional Reasoning
Student Manual
Version 3

Name



Unit 3 . Measurement and Proportional Reasoning

Table of Contents

Lesson 1.....	3
Lesson 2.....	5
Lesson 4.....	10
Lesson 5.....	16
Lesson 7.....	24
Lesson 8.....	27

Task #1: Heart Rate Closing Activity

1. Find your pulse and count how many times it beats in 15 seconds.

2. Run (in place if necessary) for 2 minutes. Now take your pulse for 15 seconds. Record your result.

3. At this rate, how long would it take for your heart to beat 700,000 times? Express your answer in days. Now express your answer in days, hours, minutes, and seconds. (example: 2 days, 4 hours, 21 minutes, 15 seconds)

4. You are training for a 5K race. This morning you ran 8 miles in 1 hour. If you run the race at this speed, how many minutes will it take you to run a 5K race?

Task #2: Heart Rate Extension Activity

Find a person 30 years old or older and record his/her approximate age.

a. Measure his/her pulse for 15 seconds. What would it be in 1 minute?

b. Have the person run in place for 2 minutes. Now take his/her pulse again for 15 seconds. What would it be in 1 minute?

c. How many times would that person's heart beat if he/she ran a 5K race? (If you don't have a rate at which this person runs, assume the person can average 6 mph during the race.)

Research to find a table of values for healthy heart rates to find out if your heart rate and the other person's heart rate are healthy.

Task #4: Fuel for Thought – Student Activity Sheet Part 2

Extending the Discussion – MPG vs. Fuel Consumption

1. Complete the following chart comparing mpg and fuel consumption.

MPG	Fuel consumed to travel 100 miles

2. Use your values to sketch a graph.

3. Develop a written report explaining your observations and conclusions.

Task #5: Map Activity Sheet

You are planning a trip from _____ to _____ on Highway _____.
(city name) (city name) (Route)

You want to determine the distance between these cities by using the map. On the map, locate the legend showing the scale of miles and answer the following questions.

1. How many miles are represented by 1 inch on the map?

2. How many inches represent 5 miles? How did you get your answer?

3. How many inches are there between the two cities listed above?

4. How many miles are there between these two cities?

Task #6: Unit Conversion Problems

Medicine: A doctor orders 250 mg of Rocephin to be taken by a 19.8 lb infant every 8 hours. The medication label shows that 75-150 mg/kg per day is the appropriate dosage range. Is this doctor's order within the desired range?

Agriculture: You own an empty one acre lot. (640 acres = 1 mi²; 1 mi = 5,280 ft)

a. If 1 inch of rain fell over your one acre lot, how many cubic inches of water fell on your lot?

b. How many cubic feet of water fell on your lot?

c. If 1 cubic foot of water weighs about 62 pounds, what is the weight of the water that fell on your lot?

d. If the weight of 1 gallon of water is approximately 8.3 pounds, how many gallons of water fell on your lot?

Astronomy: Light travels 186,282 miles per second.

a. How many miles will light travel in one year? (Use 365 days in a year) This unit of distance is called a light-year.

b. Capella is the 6th brightest star in the sky and is 41 light-years from earth. How many miles will light from Capella travel on its way to earth?

c. Neptune is 2,798,842,000 miles from the sun. How many hours does it take light to travel from the sun to Neptune?

Task #7: Scaling Activity

Look at the two pictures below. The first picture is the Washington Monument in Washington DC. The second is of the Eiffel Tower in France.

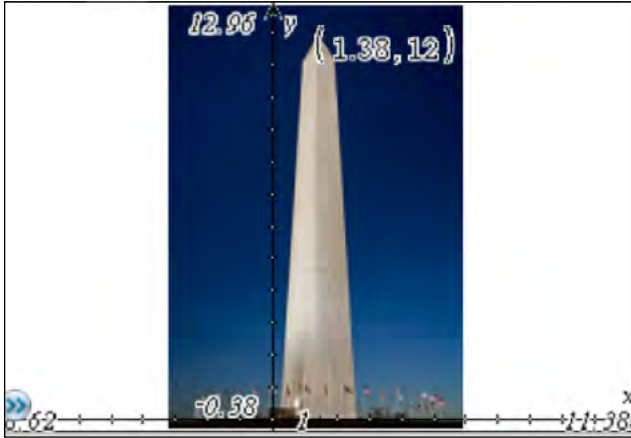

Washington Monument

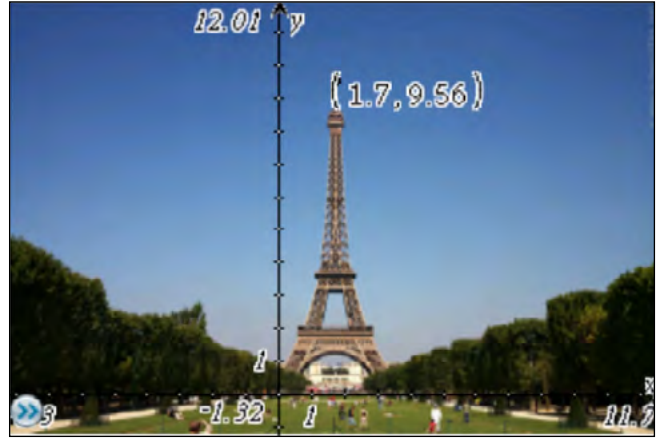

Eiffel Tower

If you just look at the diagrams which appears to be the taller object?

The scale for the Washington Monument is 1 unit \approx 46.25 feet.

The scale for the Eiffel Tower is 1 unit \approx 33.9 meters.

Round your answers to the nearest whole number.

A. Find the height of the Washington Monument.

B. Find the height of the Eiffel Tower.

Now let's think about the original question posed, which of the monuments is actually the taller? What will we have to do with our answers from A and B above to find the solution? Show and explain your work for this problem below.

Task #8: Scale Drawing Class Project

Goal: To use scale drawing to recreate a card.

Project:

1. Find two identical greeting cards or make a copy of the original card.
2. Draw a 1 cm grid on the back of the original card.
3. Number each of the squares – this will be used to assemble the final project.
4. Cut the card into squares following the grid lines.
5. Place the cut squares into a container and chose one square, record which square you selected.
6. From the teacher, receive an 8" x 8" square of white paper.
7. Reproduce and color the square that you drew from the container onto the 8" x 8" sheet of paper using scale drawing.
8. Display the final drawing by placing the squares on a wall along with the original card.

Questions:

1. Look at the finished product and evaluate the display. Did the lines match up? Which part looks the best? Which piece would have been the easiest to recreate? The hardest? Why?

2. What is the relationship of the perimeter and area between your original square and the square you created? What is the relationship of the perimeter and area of the original square to the final class project?

3. If we did the project using 4" x 4" squares how would that have affected the perimeter and area?

Task #9: Scale Drawing Individual

Goal: To select a card and enlarge it to best fit an 8 ½ “ x 11” sheet of paper.

To investigate how dimensions, perimeter and area are affected when doing scale drawings.

Please include in your project:

1. The original picture
2. The enlarged picture (colored to match original)
3. Measurements of the original picture
4. The scale selected to enlarge the picture
5. Self-Completed Evaluation

Design:

Step 1: Measure the length and width of the picture in cm. (It does not matter which side you label the length and width; be consistent with your sides on the large paper)

Length _____ Width _____

Step 2: Draw a 1 cm grid on the original card (Draw 1 cm tick marks going across the length and the width and then connect your marks to form a grid, these measurements need to be accurate)

Step 3: Measure the paper in cm.

Length _____ Width _____

Step 4: Select a scale (1 cm on card = _____ cm on paper)

- To do this find the ratio of lengths and widths

i.e.: $\frac{L_p}{L_c} = \frac{\quad}{\quad} = \frac{\quad}{\quad}$ $\frac{W_p}{W_c} = \frac{\quad}{\quad} = \frac{\quad}{\quad}$

- Then pick the smallest of the two numbers to the nearest whole number (i.e. if you get 4.29 and 4.76 your scale should be 1 cm card = 4 cm on paper)

Step 5: Draw the borders

- Multiply your length and width of the card by your scale factor and see how much of the paper you have left over for the border. Take this number and divide by two because the border should be on both sides.

i.e. $L_c \times \text{Scale Factor} = \quad$ Then $(L_p - \quad)/2 = \quad$
 $W_c \times \text{Scale Factor} = \quad$ Then $(W_p - \quad)/2 = \quad$

Step 6: Draw a grid on your paper using your scale. (i.e. If your scale is 1:4, your grid on your large paper will be 4 cm x 4 cm; therefore, you would draw 4 cm tick marks going across the length and width and then connect your marks to form a grid.)

Step 7: Reconstruct drawing and color accordingly. Erase your grid marks on your final product before submitting the project! Higher scores will reflect a near-perfect representation of the smaller card frame. Colors, shading, and drawing should look identical!

1. What is the length and width of the squares of the small graph?

Length = _____ Width = _____

2. What is the length and width of the squares of the large graph?

Length = _____ Width = _____

3. What is the perimeter and area of each square on the small graph?

Perimeter = _____ Area = _____

4. What is the perimeter and area of each square on the large graph?

Perimeter = _____ Area = _____

5. How do the lengths of the small and large squares compare (answer as a fraction)?

Answer: _____

6. How do the widths of the small and large squares compare (answer as a fraction)?

Answer: _____

7. How do the perimeters compare (answer as a fraction)?

Answer: _____

8. How do the areas compare (answer as a fraction)?

Answer: _____

9. What is the length and width of the original card?

Length = _____ Width = _____

10. What is the length and width of the enlarged card?

Length = _____ Width = _____

11. What is the perimeter of the original card?

Perimeter = _____

12. What is the perimeter of the enlarged card?

Perimeter = _____

13. How do the two perimeters compare (answer as a fraction)?

Answer: _____

14. What is the area of the original card?

Area: _____

15. What is the area of the enlarged card?

Area: _____

16. How do the two areas compare (answer as a fraction)?

Answer: _____

17. Are the comparisons for perimeter and area the same? Explain why you think this happened.

Yes or No

Scale Drawing Project Rubric

NOTE: When you submit your project, you will first score yourself using this rubric. Be honest and thorough in your evaluation. Remember to include the following parts in your presentation:

1. The original picture
2. The enlarged picture (colored to match original)
3. Measurements of the original picture
4. The scale selected to enlarge the picture
5. Self-Completed Evaluation

	10 – 9	8 – 7	6 – 5	4 - 0
Scale	All calculations and proportions are shown.	Most calculations and proportions are shown.	Few calculations and proportions are shown.	No calculations and proportions are shown.
Grids	All grid lines can be seen on card (grid lines on enlarged picture should be erased, but should appear faintly). All lines are parallel and measured correctly.	Most grid lines can be seen on card (grid lines on enlarged picture should be erased, but should appear faintly). Most lines are parallel and measured correctly.	Few grid lines can be seen on card (grid lines on enlarged picture should be erased, but should appear faintly). Few lines are parallel and measured correctly.	No grid lines can be seen on card (grid lines on enlarged picture should be erased, but should appear faintly). No lines are parallel, nor measured correctly.
Reconstruction	All proportions are accurate on the enlarged picture.	Most proportions are accurate on the enlarged picture.	Few proportions are accurate on the enlarged picture.	No proportions are accurate on the enlarged picture.
Presentation	The enlarged picture is colored neatly in the lines and colors match original card.	Most of the enlarged picture is colored neatly in the lines and most of the colors match original card.	Some of the enlarged picture is colored neatly in the lines and some of the colors match original card.	The enlarged picture is not colored neatly in the lines and does not match original card.

Total Points Possible: 40

Self-Assessment:

Scale: _____/10

Grids: _____/10

Reconstruction: _____/10

Presentation: _____/10

Total Points: _____/40

Comment on your level of effort and accuracy on this project:

Teacher-Assessment:

Scale: _____/10

Grids: _____/10

Reconstruction: _____/10

Presentation: _____/10

Total Points: _____/40

Teacher Comments:

Adapted from the lesson Cartoons and Scale Drawings created by Sara Wheeler for the Alabama Learning Exchange. http://alex.state.al.us/lesson_view.php?id=26285

Task #10: Comparing TV Areas

Does an 80" TV Really Have More Than Twice the Area of a 55" TV?



1. What does the 80 inches represent in an 80" TV?

2. Find the area of an 80" TV if the ratio of the length to the height is 16:9.

3. Find the area of a 55" TV. The ratio of the length to the height is the same.

4. How much more area does the 80" TV have than the 55" TV?

5. Is the advertisement accurate?

Task #11: Area and Perimeter of Irregular Shapes

Find the area and perimeter of each of the following shapes.

1.

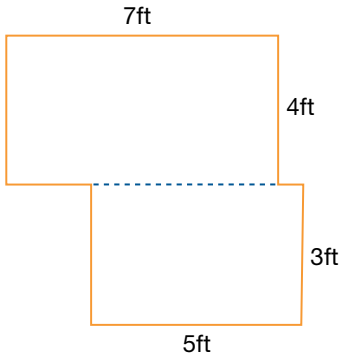

Perimeter = _____

Area = _____

2.

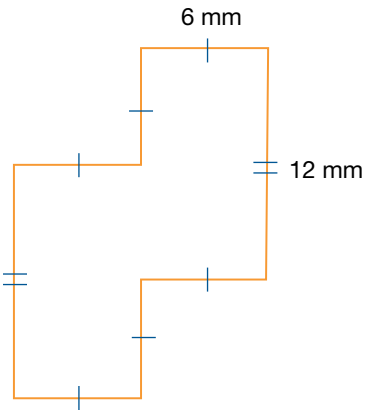

Perimeter = _____

Area = _____

3.

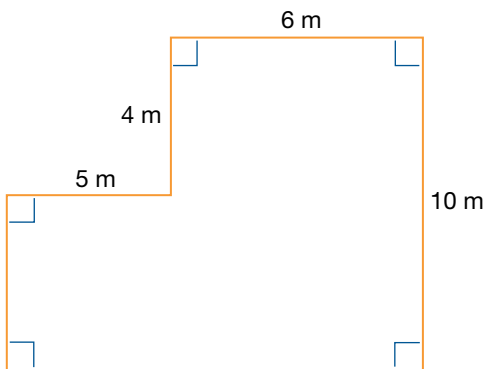

Perimeter = _____

Area = _____

4.

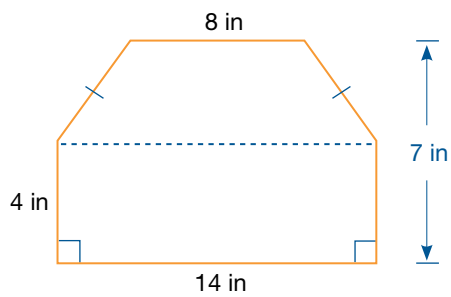

Perimeter = _____

Area = _____

5.

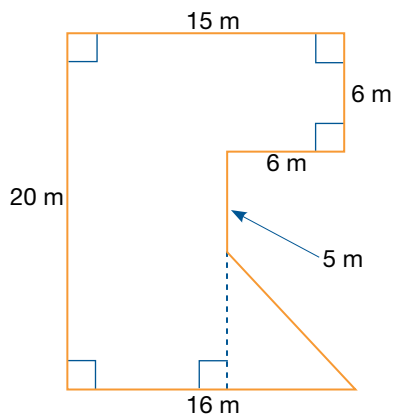

Perimeter = _____

Area = _____

(Source: freemathsource.com)

Task #12: Area Problems

Find the area and perimeter of each of the following shapes.

1. Find the largest possible rectangular area you can enclose with 96 meters of fencing. What is the (geometric) significance of the dimensions of this largest possible enclosure? What are the dimensions in meters? What are the dimensions in feet? What is the area in square feet?

2. The riding stables just received an unexpected rush of registrations for the next horse show, and quickly needs to create some additional paddock space. There is sufficient funding to rent 1200 feet of temporary chain-link fencing. The plan is to form two paddocks with one shared fence running down the middle. What is the maximum area that the stables can obtain, and what are the dimensions of each of the two paddocks?

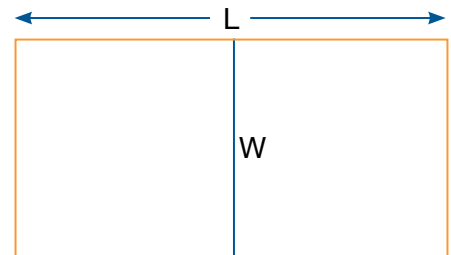

3. A farmer has a square field that measures 100 m on a side. He wants to irrigate as much of the field as he possibly can using a circular irrigation system.

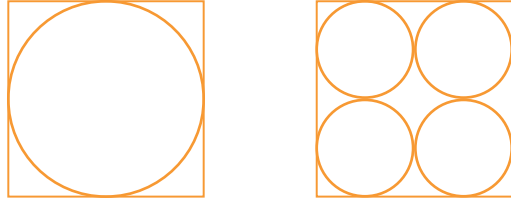

a. Predict which irrigation system will irrigate more land?

b. What percent of the field will be irrigated by the large system?

c. What percent of the field will be irrigated by the four smaller systems?

d. Which system will irrigate more land?

e. What generalization can you draw from your answers?

Task #13: Paper Clip Activity

This paper clip is just over 4 cm long.

How many paper clips like this can be made from a straight piece of wire 10 meters long?

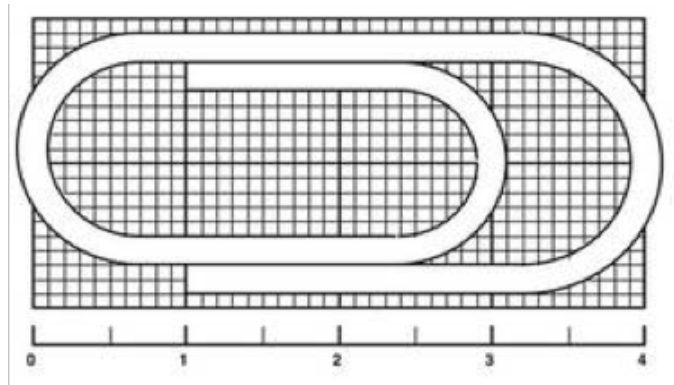

Task #14: Race Track Problem

A track has lanes that are 1 meter wide. The turn-radius of the inner lane is 24 meters and the straight parts are 80 meters long. In order to make the race fair, the starting lines are staggered so that each runner will run the same distance to the finish line.

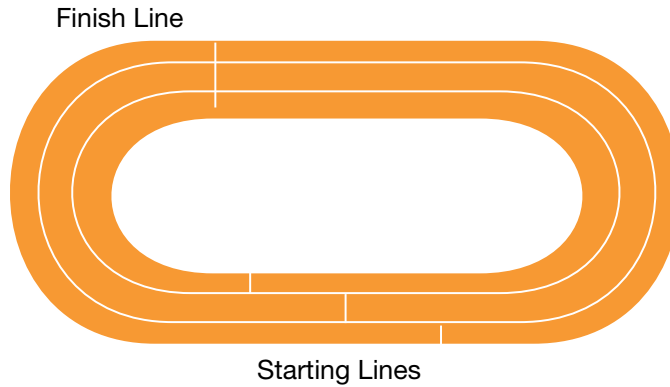

a. Find the distances between the starting lines in neighboring lanes.

b. Is the distance between the starting lanes for the first and second lane different from the distance between the starting lanes for the second and third lanes?

c. What assumptions did you make in doing your calculations?

Task #15: Area & Perimeter Exit Slip

DIRECTIONS: Calculate the perimeter and the area of each rectangle.

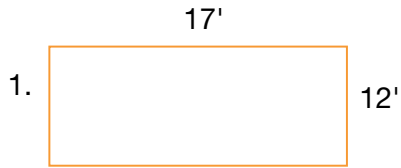

Perimeter = _____

Area = _____

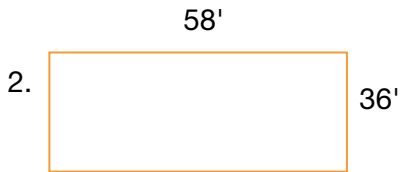

Perimeter = _____

Area = _____

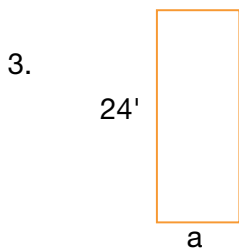

Perimeter = _____

Area = _____

4. A rectangle has an area of 2,130' and a width of 30', find its length and perimeter.

5. The perimeter of the triangle below is 52 cm. Find the length of each side of the triangle. Show your calculations.

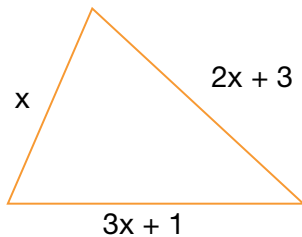

Task #16: Quadrilateral Activity

1. Points $A(1, 3)$, $B(-3, 1)$, $C(-1, -3)$, $D(3, -1)$ form a square
 - a. Graph the points and connect them.

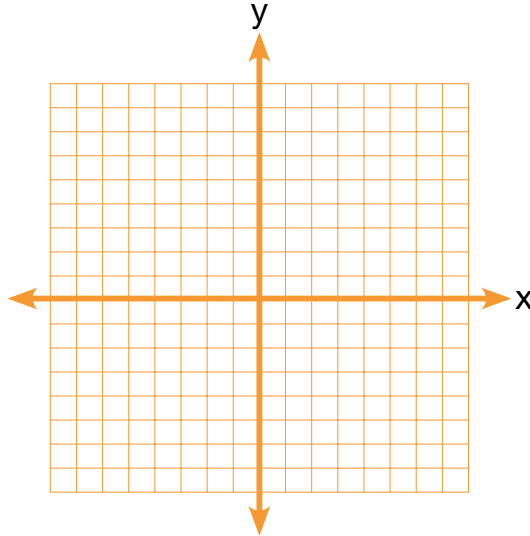

- b. List as many properties of a square as you can.

- c. Show algebraically that the property assigned to your group is true for this square and all squares.

- d. Find the area and perimeter of ABCD.

2. Consider the points $F(-4, -1)$, $G(-2, -5)$, $H(4, -2)$ and $J(2,2)$.

a. Graph the points.

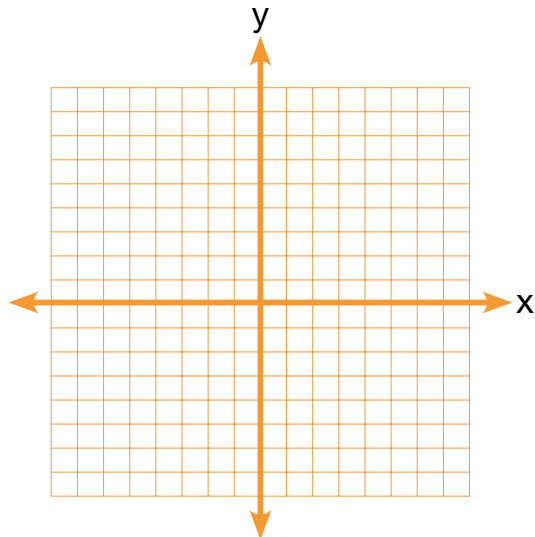

b. What type of quadrilateral is $FGHJ$? Justify your reasoning.

3. Consider the points $K(-2, -1)$, $L(-1, 2)$, $M(2, 4)$ and $N(1,1)$.

a. Graph the points.

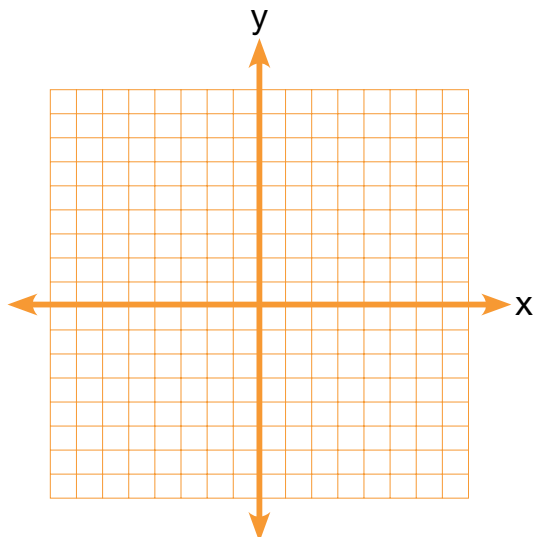

b. What type of quadrilateral is $KLMN$? Show your work and justify your reasoning.

Task #17: Propane Tank Activity

Propane Tanks

People who live in isolated or rural areas have their own tanks of natural gas to run appliances like stoves, washers, and water heaters.

These tanks are made in the shape of a cylinder with hemispheres on the ends.

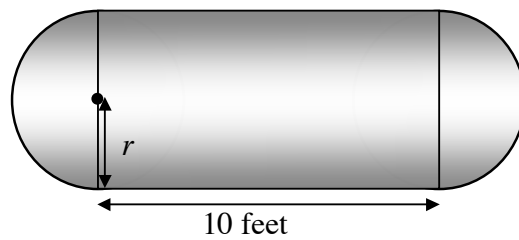

The Insane Propane Tank Company makes tanks with this shape, in different sizes.

The cylinder part of every tank is exactly 10 feet long, but the radius of the hemispheres, r , will be different depending on the size of the tank.

The company want to double the capacity of their standard tank, which is 6 feet in diameter.

What should the radius of the new tank be? _____

Explain your thinking and show your calculations.

Task #18: Toilet Roll

Picture a roll of toilet paper; assume that the paper in the roll is very tightly rolled. Assuming that the paper in the roll is very thin, find a relationship between the thickness of the paper, the inner and outer radii of the roll, and the length of the paper in the roll. Express your answer as an algebraic formula involving the four listed variables.

- R_i = inner radius
- R_o = outer radius
- t = thickness of the toilet paper
- L = length of the toilet paper

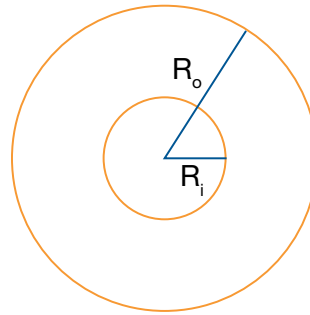

(Source: Illustrative Mathematics)

SREB

SREB Readiness Courses
Transitioning to college and careers

College Readiness Mathematics

Unit 4 . Linear Functions
Version 3

Southern
Regional
Education
Board

592 Tenth Street, NW
Atlanta, GA 30318
(404) 875-9211

www.sreb.org

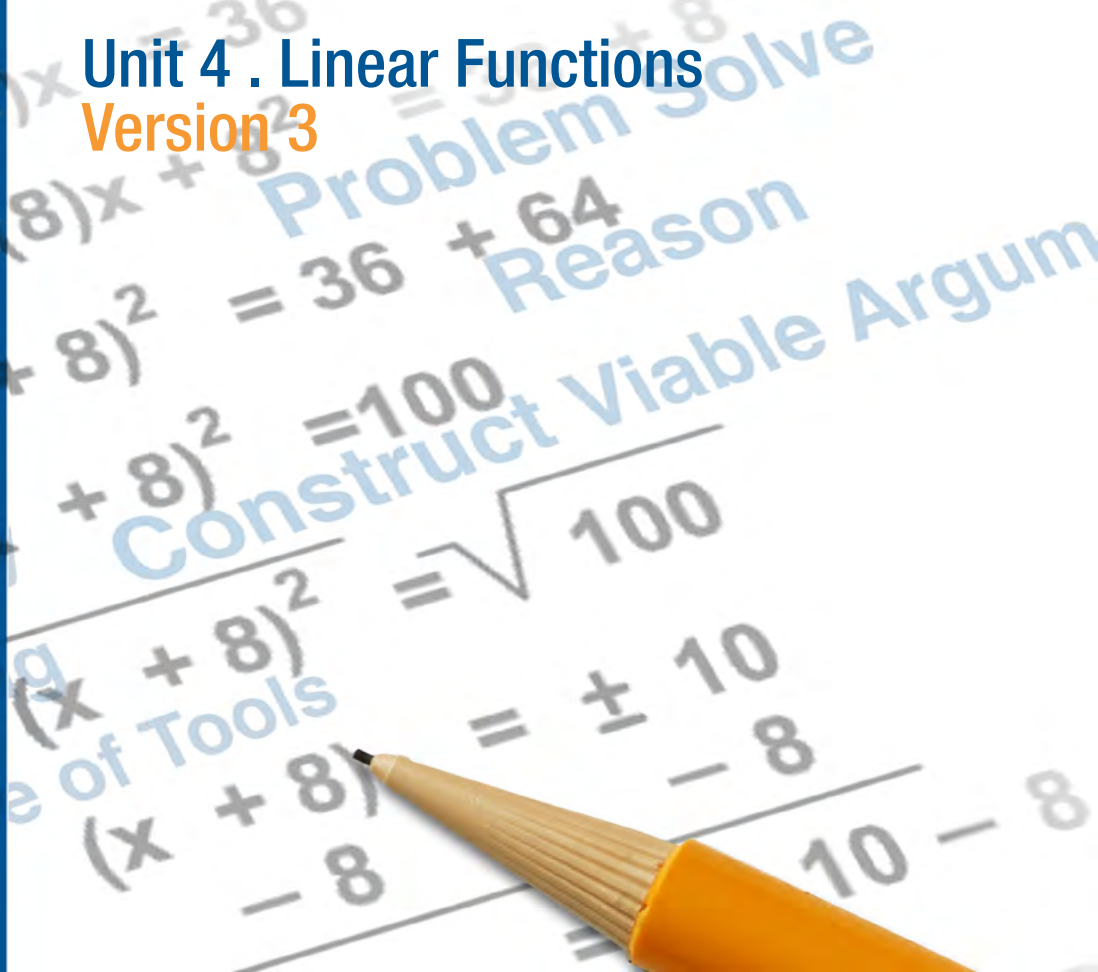

Unit 4 . Linear Functions

Overview

Purpose

This unit will provide students an in-depth study of linear functions with a focus on the context of real-life mathematical problems. Students will begin with a review of functions in general by categorizing a variety of relations as either functions or non-functions given in various representations. A lesson on proportionality leads into more complex linear equations where students must identify intercepts and slope and be able to explain their meaning in context. The unit concludes with real-life data that students must use to create a line of best fit, all the while understanding the implications this equation has on making accurate predictions.

Essential Questions:

How can we distinguish a function from a non-function and linear function from a non-linear function by studying their tables, graphs, and/or equations?

How can we identify slope and y-intercept in a given context?

How can we use a small set of (fairly) linear data to make predictions?

Georgia Standards of Excellence:

Expressions and Equations

Understand the connections between proportional relationships, lines and linear equations.

- EE.1 Graph proportional relationships, interpreting the unit rate as the slope of the graph. Compare two different proportional relationships represented in different ways.
- EE.2 Use similar triangles to explain why the slope m is the same between any two distinct points on a non-vertical line in the coordinate plane; derive the equation $y = mx$ for a line through the origin and the equation $y = mx + b$ for a line intercepting the vertical axis at b .

Functions

Define, evaluate and compare functions.

- MGSE8.F.1: Understand that a function is a rule that assigns to each input exactly one output. The graph of a function is the set of ordered pairs consisting of an input and the corresponding output.
- MGSE8.F.2: Compare properties of two functions each represented in a different way (algebraically, graphically, numerically in tables, or by verbal descriptions). *For example, given a linear function represented by a table of values and a linear function represented by an algebraic expression, determine which function has the greater rate of change.*
- MGSE8.F.3: Interpret the equation $y = mx + b$ as defining a linear function whose graph is a straight line; give examples of functions that are not linear. For example, the function $A = s^2$ giving the area of a square as a function of its side length is not linear because its graph contains the points (1, 1), (2, 4) and (3, 9), which are not on a straight line.

Use functions to model relationships between quantities.

- MGSE8.F.4: Construct a function to model a linear relationship between two quantities. Determine the rate of change and initial value of the function from a description of a relationship or from two (x,y) values, including reading these from a table or from a graph. Interpret the rate of change and initial value of a linear function in terms of the situation it models, and in terms of its graph or a table of values.

Creating Equations

Create equations that describe numbers of relationships.

- MGSE9-12.A.CED.2: Create linear, quadratic, and exponential equations in two or more variables to represent relationships between quantities; graph equations on coordinate axes with labels and scales. (The phrase “in two or more variables” refers to formulas like the compound interest formula, in which $A = P(1 + r/n)^{nt}$ has multiple variables.)

Interpreting Functions

Interpret functions that arise in applications in terms of the context.

- MGSE9-12.F.IF.4: Using tables, graphs, and verbal descriptions, interpret the key characteristics of a function which models the relationship between two quantities.

Sketch a graph showing key features including: intercepts; interval where the function is increasing, decreasing, positive, or negative; relative maximums and minimums; symmetries; end behavior; and periodicity.

Analyze functions using different representations.

- F.MGSE9-12.F.IF.7: Graph functions expressed algebraically and show key features of the graph both by hand and by using technology.
- MGSE9-12.F.IF.7a: Graph linear and quadratic functions and show intercepts, maxima and minima (as determined by the function or by context).
- MGSE9-12.F.IF.9: Compare properties of two functions each represented in a different way (algebraically, graphically, numerically in tables, or by verbal descriptions). For example, given a graph of one function and an algebraic expression for another, say which has the larger maximum.

Linear, Quadratic, and Exponential Models

Construct and compare linear, quadratic, and exponential models to solve problems.

- MGSE9-12.F.LE.1: Distinguish between situations that can be modeled with linear functions and with exponential functions.
- MGSE9-12.F.LE.3: Observe using graphs and tables that a quantity increasing exponentially eventually exceeds a quantity increasing linearly, quadratically, or (more generally) as a polynomial function.

Interpreting Categorical and Quantitative Data

Summarize, represent, and interpret data on two categorical and quantitative variables.

- SMGSE9-12.S.ID.6: Represent data on two quantitative variables on a scatter plot, and describe how the variables are related.
- MGSE9-12.S.ID.6c: Using given or collected bivariate data, fit a linear function for a scatter plot that suggests a linear association.

Interpret linear models

- MGSE9-12.S.ID.7: Interpret the slope (rate of change) and the intercept (constant term) of a linear model in the context of the data.

Prior Scaffolding Knowledge / Skills:

- Students should be able to recognize and analyze proportional relationships to solve real-world and mathematical problems.
- Students should be able to compute the unit rate of a proportional relationship and recognize the importance and use units in this process.
- Students should be able to analyze and solve multistep ratio and percent problems.
- Students should be familiar with linear equations and have methods to analyze and solve simple linear equations in one variable.
- Students should have a working definition of functions by understanding that a function is a rule that assigns to each input exactly one output.

Lesson Progression Overview:

Lesson Big Idea	Lesson Details	Georgia Standards of Excellence	Standards for Mathematical Practice
Lesson 1: Linear and Nonlinear Functions	In this lesson, students will look at examples and non-examples of functions by comparing graphs, tables, maps and equations. They will then look more closely at linear and nonlinear functions and determine the rate of change for a set of linear functions. Students will see multiple representations of functions to be used as tools in problem solving later in the unit.	MGSE8.F.1 MGSE8.F.3 MGSE9-12.F.IF.9	SMP 7 SMP 8
Lesson 2: Comparing Proportional Relationships	Students will explore proportional relationships and mathematical terms associated with them such as independent and dependent variables, unit rate, and slope. These terms will be presented in the context of real-world mathematical problems and students will be expected to explain in the context of the problem. Students will also compare a proportional relationship given in a table with one described in words. They will then graph and compare their rates of change.	MGSE8.EE.5 MGSE8.EE.6	SMP 1 SMP 3 SMP 4
Lesson 3: Linear Equations in Context: Graphing and Describing Key Features	In this lesson, students will be asked to identify and describe key features and characteristics of linear functions in the form of an equation and graphically. They will again be asked to explain the meaning of the slope in context as well as the meaning of the intercepts. Students will see linear equations in both y-intercept and standard form and will graph the functions. Additionally, they will be asked to identify domain and range of linear functions.	MGSE8.F.4 MGSE9-12.F.IF.7 MGSE9-12.F.IF.7a MGSE9-12.S.ID.7	SMP 1 SMP 3 SMP 4
Lesson 4: Writing Equations of Lines	Students will now turn their attention towards writing equations of lines given various pieces of information. Once they have practiced writing equations given two points, students will revisit the iTunes app problem and will write an equation for the data collected during the hook. Students will then write several equations given different situations. They must identify the slope and any intercepts as well as explaining these features in the context of the problem.	MGSE8.F.4 MGSE9-12.A.CED.2 MGSE9-12.S.ID.7	SMP 4 SMP 6
Lesson 5: Formative Assessment Lesson: Lines and Linear Equations	Students will complete the formative assessment lesson Lines and Linear Equations from the Shell Center. This lesson will assess students' understanding of slope and their ability to translate between linear equations and their graphs.	MGSE8.EE.5 MGSE8.EE.6 MGSE8.F.1 MGSE8.F.2 MGSE8.F.3	SMP 2 SMP 4 SMP 7

Lesson Big Idea	Lesson Details	Georgia Standards of Excellence	Standards for Mathematical Practice
Lesson 6: Applications of Linear Functions	<p>In this lesson, students will be able to apply what they have learned about linear functions by simulating a bungee jump. Students will use balloons filled with water and rubber bands to collect data and will then use that data to write the equation of a line of best fit. This equation will be used to predict the number of rubber bands needed to provide a safe, yet thrill-seeking jump for the jumper (i.e., the balloon). Not only will students need to write an equation from two points, but will again be asked to explain the slope and y-intercept in the context of the problem. They will conclude by completing an activity report describing the activity in its entirety. This will allow the teacher to determine not only if the student understands the mathematics but also if the student can adequately explain the process of the activity.</p>	MGSE9-12.S.ID.6	SMP 1 SMP 3 SMP 4
Lesson 7: Culminating Task – When will the 25 billionth iTunes app be down- loaded?	<p>Students will use their knowledge of linear functions to predict the time and date in which the 25 billionth iTunes app was downloaded. Using the same 16-minute video shown at the beginning of the unit, students will collect their own data and write an equation to best model that data.</p> <p>To conclude, students will examine data provided on the number of iTunes apps downloaded from 2008-2012. After graphing this data, students will then compare the graph to their graphs. This activity will give students the opportunity to realize how data collected over a short interval can look very different than data collected over an extended period of time. Students will have an opportunity to discuss factors that may contribute to the differences in the graphs and will be introduced to local linearity.</p>	MGSE9-12.S.ID.6 MGSE9-12.F.LE.1 MGSE9-12.F.LE.3	SMP 1 SMP 2 SMP 3

All lessons are designed for students to work collaboratively in groups of two to four unless otherwise noted.

Linear Functions

Lesson 1 of 7

Linear and Nonlinear Functions

Description:

In this lesson, students will look at examples and non-examples of functions by comparing graphs, tables, maps and equations. They will then look more closely at linear and nonlinear functions and determine the rate of change for a set of linear functions. Students will see multiple representations of functions to be used as tools in problem solving later in the unit.

Georgia Standards of Excellence Addressed:

- F.MGSE8.F.1: Understand that a function is a rule that assigns to each input exactly one output. The graph of a function is the set of ordered pairs consisting of an input and the corresponding output.
- MGSE8.F.3: Interpret the equation $y = mx + b$ as defining a linear function whose graph is a straight line; give examples of functions that are not linear. For example, the function $A = s^2$ giving the area of a square as a function of its side length is not linear because its graph contains the points (1, 1), (2, 4) and (3, 9), which are not on a straight line.
- MGSE9-12.F.IF.9: Compare properties of two functions each represented in a different way (algebraically, graphically, numerically in tables, or by verbal descriptions). For example, given a graph of one function and an algebraic expression for another, say which has the larger maximum.

Standard(s) for Mathematical Practice Emphasized:

- SMP 7: Look for and make use of structure.
- SMP 8: Look for and express regularity in repeated reasoning.

Sequence of
Instruction

Activities Checklist

Engage

Entry Event: On February 13, 2012, Apple Inc. announced the *25 Billion Apps Countdown* promotion which would award a \$10,000 (U.S. dollars) iTunes store gift card to the person who downloaded the 25 billionth app. Apple displayed a counter on their website so that customers could see the current number of downloaded apps. Dan Meyer posted this problem on his blog (<http://blog.mrmeyer.com>) on February 27, 2012. The video from Dan (<http://vimeo.com/37382647>) titled *25 Billion Downloads – Act Two* is a 16-minute video of the app download “count up.” In this video, you can see the date and time from Dan’s computer when the clip was recorded (Friday, February 24 at 6:26 p.m. PST).

Begin class with the 16-minute video playing in the background. Explain Apple’s promotion and pose the question “*When will the 25 billionth iTunes app be downloaded?*” Instruct students to work in their groups of three to four to discuss the question and arrive at an estimation of the date in which the 25 billionth app was downloaded. Students should be given seven to 10 minutes before being asked to provide their estimation to the teacher. (Note: The teacher may want to remind students that 2012 was a leap year.)

In a whole group discussion, students should share their thought processes on how they arrived at their estimation. *Was it just a guess or did you use a mathematical method and if so, what was it?* This discussion (and the group discussions described above) will also serve to informally pre-assess students on their knowledge going into this unit. Do they notice that the data is linear? Do they mention vocabulary such as “constant rate of change” or “slope?” Did they, perhaps, use a creative method of estimating without realizing the data is linear? The teacher should list on chart paper key vocabulary mentioned by students as they discuss in whole group.

Display the 90-second sample data from the video and pose the question, “What does this data tell us?” If students have not already mentioned key vocabulary, this is an opportunity for them to notice the linear pattern. (If any groups collected data themselves, consider displaying their data rather than the sample data.)

Time(s)	# on Counter
0	24,658,491,600
10	24,658,497,385
20	24,658,503,379
30	24,658,508,754
40	24,658,514,729
50	24,658,520,201
60	24,658,525,886
70	24,658,531,626
80	24,658,537,338
90	24,658,543,074

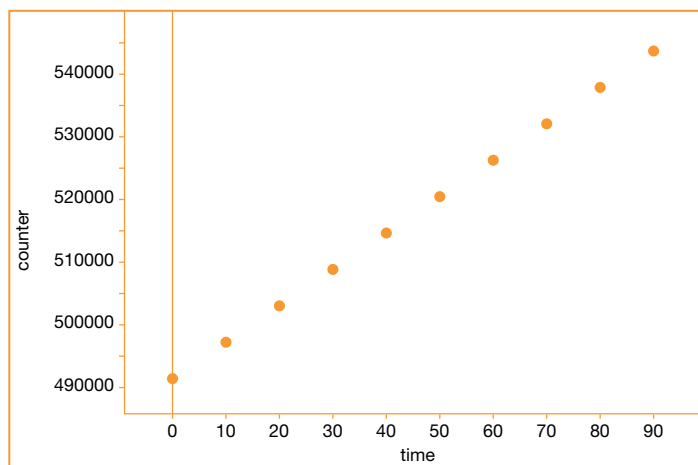

To conclude, give students a brief explanation of how this problem relates to the unit of study. At this point, we do not want to go into the details of calculating a line of best fit as this problem will be revisited in Lesson 4 allowing students to do that work.

This problem will also be revisited in a culminating task at the end of the unit. At this point, students will not be told the exact time and date of the 25 billionth download, although some will likely go home and look it up on the web. If this occurs, remind them that mathematics is about the process, not just the product and what we are interested in is the process they used to estimate the date of the 25 billionth download.

Explore



Students should begin by taking five to 10 minutes to research the definition of a function and some examples of functions. They may use the Internet, books, etc., for the research.

Each group is then handed a set of cards with graphs, tables, maps and equations (card sorting). Students must sort into two groups—functions and non-functions—while the teacher monitors and listens to discussions. Throughout the activity,

encourage students to refer back to their definition of function to help make sense of the definition in terms of the relations given on the cards.

For students struggling to get started on this activity, encourage them to begin by looking only at the graphs. Then, look simultaneously at the maps and tables. For the equations, encourage students to test values to see if the equation will yield two y -values for one x -value. Students should look for regularity in functions represented in multiple ways. The following questions may help to guide this discussion:

- *What can help you determine a function from a non-function graphically?*
- *How can your graphical method for identifying functions help you when the data is provided in a table?*
- *Are there any x -values that are mapped to two different y -values?*
- *(For equations) Could an x -value possibly have two distinct y -values?*

Solutions for card sorting functions/non-functions:

Functions – A, C, E, G, I, K, M, O, Q, R, S, T, U, V, W, X

Non-functions – B, D, F, H, J, L, N, P

Explanation



Each student group should collaborate with one other group to check if their cards were sorted the same. If discrepancies exist, students should discuss areas of disagreement.

Based on research and card sort, students should now work together to agree on a definition of a function in a whole-group setting. Give students a Frayer Model for functions and ask them to complete. They should include examples and non-examples different from those in the card sort but can refer to the cards if needed.

INCLUDED IN THE STUDENT MANUAL

Frayer Map

Definitions		Characteristics	
Examples		Function	
		Non-Examples	

In this course, students should be able to fluently move between four forms of a function (equation, table, graph, and map) independent of one another. During the whole-group discussion, the teacher should use questions (see below for examples) to direct student discourse toward the structure of functions (and non-functions).

- *What distinguishes a function from a non-function in a table? A graph? An equation? A map?*
- *What key features of the graphs and tables helped you to classify it as a function (or non-function)?*
- *How can the structure of an equation help you to classify it as a function or a non-function?*

Explore



Now ask students to separate the “function” cards into two categories given no further directions. (Cards represent a variety of functions although most are linear. Students should be able to quickly separate graphs/equations of lines from graphs/equations of nonlinear functions but will have to read the tables and maps carefully in order to sort.) If students are struggling, the teacher should direct them to look at only the graphs first. Here, students should easily distinguish the five lines from the quadratic and exponential functions.

Again, bring students’ attention to the structure of linear functions using the following questions:

- *How is the structure of a linear function different from that of a non-linear function?*
- *How can you see a linear pattern in a table?*
- *How does the graph of a line compare to a linear table?*

This is also an opportunity to discuss the appropriate and strategic use of tools, particularly the tools used to represent functions. Although in this activity students are matching the different representations of functions rather than selecting one themselves, students should see these different representations as tools that they can use when asked to problem solve.

Possible Solutions:

Linear – C, E, I, K, M, O, Q, R, S, U, V

Non-linear – A, G, T, W, X

Practice Together in Small Groups



Now students will use ONLY the linear function cards. Students in groups of four should each take a card. They must then find the rate of change for their function. While students are determining the rate of change, be aware that some students may need a brief refresher. This should be determined formatively as you monitor group work and addressed with individual groups on a rotating basis, if needed. If the entire class is struggling, perhaps pose a question, “What is rate of change?” and let the students drive the discussion.

Students then switch cards with their shoulder partner and find that rate of change. Next, they compare answers and discuss with shoulder partner.

Students can then switch with their face partners to find a new rate of change. They can continue this process as long as practice is needed or until all rates of change have been calculated.

Students should use repeated reasoning to make sense of rate of change.

A connection should be made between counting the horizontal and vertical distances on a graph and the formula for slope.

Possible Solutions:

Card	C	E	I	K	M	O	Q	R	S	U	V
Rate of change	$\frac{1}{2}$	5	0	$\frac{1}{2}$	2	$\frac{2}{3}$	-2	$-\frac{2}{3}$	$\frac{1}{5}$	-50	-4

Evaluate Understanding

Lead students in a whole-group discussion on the characteristics of linear functions. Use the following questions to guide the discussion:

- *What patterns do you observe in the tables and graphs of the linear functions?*
- *(Display both a linear and exponential graph from the card sort) Why is the exponential graph NOT linear? How does its rate of change compare to that of the linear function?*
- *How many times can a linear function intersect the x-axis? Is this true for all functions?*
- *How many times can a linear function intersect the y-axis?*
- *Is this true for all functions?*

Closing Activity

INCLUDED IN THE STUDENT MANUAL

Task #1: Journal Entry

For the situation, write a journal entry explaining how the rate of change can be identified in the written scenario, on the graph, and in the table. Make sure to fully explain using mathematical language.

Isabella's electric company charges \$0.15 per kWh (Kilowatt hour) plus a basic connection charge of \$20 per month.

kWh	Monthly bill
0	\$20
100	\$35
200	\$50
500	\$95
1000	\$170

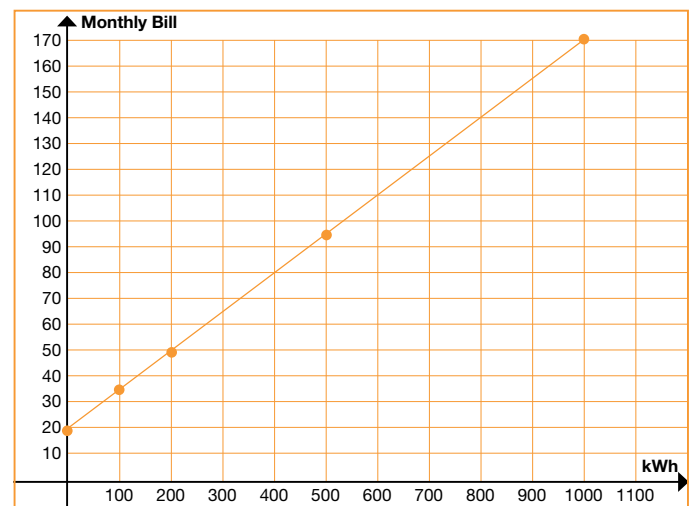

Independent Practice:

Ask students to find an online article about a situation that represents a function and explain the article using mathematical terms.

Resources/Instructional Materials Needed:

- 16-minute video of the app countdown (<http://vimeo.com/37382647>)
- *Card Sorting: Function or Not?* (cut out on cardstock)

Linear Functions

Card Sorting: Function or Not?

A

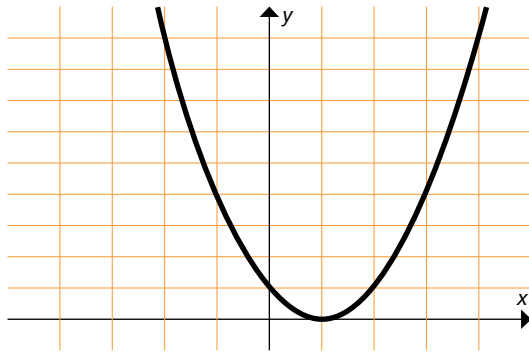

B

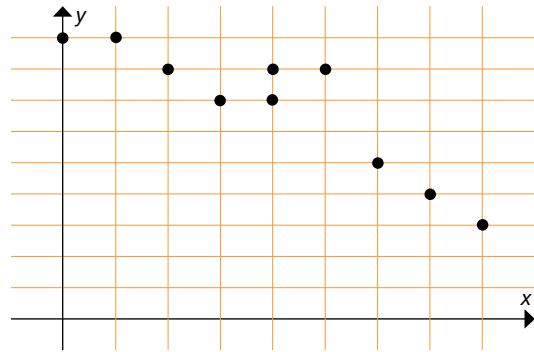

C

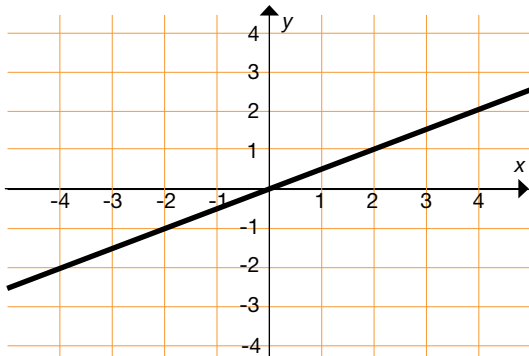

D

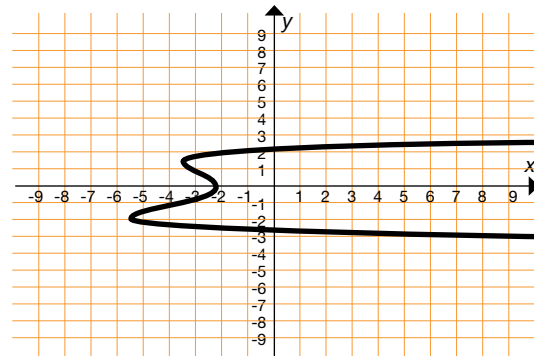

E

x	y
0	5
1	10
2	15
3	20

F

x	y
24	-13
24	-7
24	0
24	11

G

x	y
1	1
2	4
3	9
4	16

H

x	y
-7	13
0	10
9	21
-7	-6

Linear Functions

Card Sorting: Function or Not?

<p>I</p> <p>Input: 12, 20, 24, 36 Output: 120</p>	<p>J</p> <p>Input: 42, 50, 64 Output: 120, 200</p>
<p>K</p> <p>Input: -6, -4, -2, 0 Output: 6, 7, 8, 9</p>	<p>L</p> <p>Input: 5 Output: 7, 8, 9, 10</p>
<p>M</p> $y = 2x + 1$	<p>N</p> $y^2 = 2x - 4$
<p>O</p> $y = \frac{2}{3}x - 48$	<p>P</p> $x^2 + y^2 = 25$

Linear Functions

Card Sorting: Function or Not?

Q

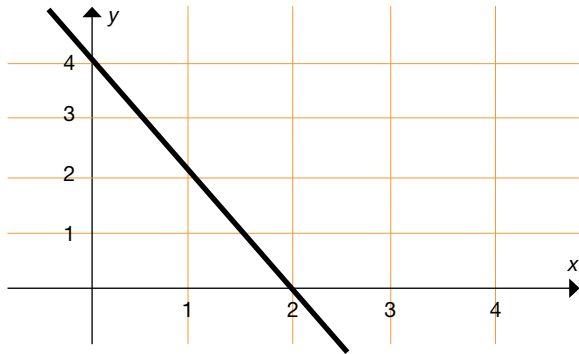

R

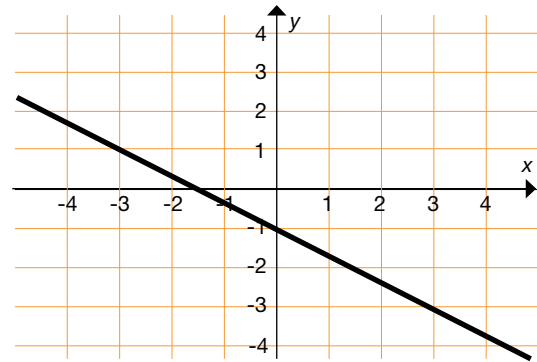

S

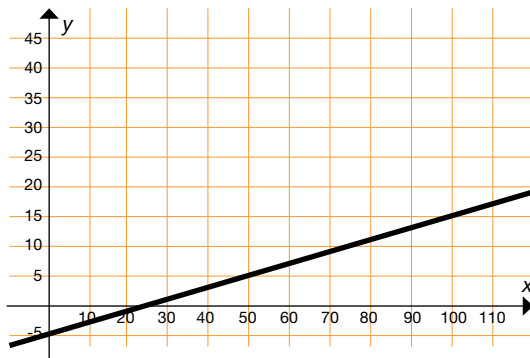

T

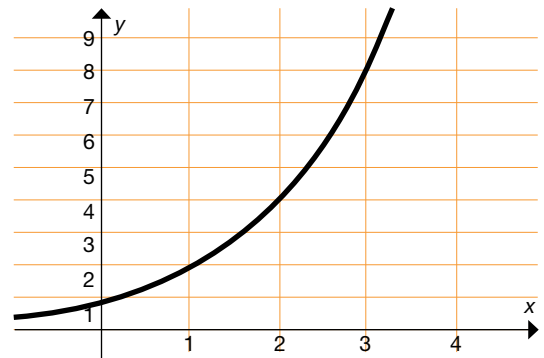

U

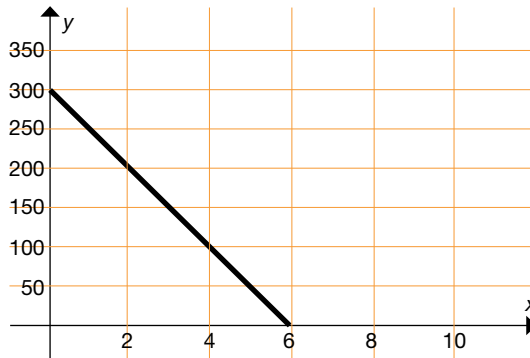

V

x	y
2	-7
3	-11
7	-27
10	-39

W

x	y
0	0
1	2
2	4
3	8

X

x	y
1	64
2	32
3	16
4	8

Linear Functions

Lesson 2 of 7

Comparing Proportional Relationships

Description:

Students will explore proportional relationships and mathematical terms associated with them such as independent and dependent variables, unit rate, and slope. These terms will be presented in the context of real-world mathematical problems and students will be expected to explain in the context of the problem. Students will also compare a proportional relationship given in a table with one described in words. They will then graph and compare their rates of change.

Georgia Standards of Excellence Addressed:

- EMGSE8.EE.5 Graph proportional relationships, interpreting the unit rate as the slope of the graph. Compare two different proportional relationships represented in different ways. *For example, compare a distance-time graph to a distance-time equation to determine which of two moving objects has greater speed.*
- MGSE8.EE.6 Use similar triangles to explain why the slope m is the same between any two distinct points on a non-vertical line in the coordinate plane; derive the equation $y = mx$ for a line through the origin and the equation $y = mx + b$ for a line intercepting the vertical axis at b .

Standard(s) for Mathematical Practice Emphasized:

- SMP 1: Make sense of problems and persevere in solving them.
- SMP 3: Construct viable arguments and critique the reasoning of others.
- SMP 4: Model with mathematics.

Sequence of
Instruction

Activities Checklist

Engage



To begin this lesson, students will demonstrate their understanding of slope. Pose the *Peaches and Plums* problem for students to work through and discuss. Give students one to two minutes to think about the problem individually and then three to four minutes to discuss with their group. Circulate the classroom to gauge students' understanding of slope listening carefully for discussions about the steepness of the lines. Students should be modeling with mathematics as they analyze the relationship between the number of pounds and cost and then apply that knowledge to answer the questions. The absence of a scale on the axes requires students to communicate about the context

of the problem. As always, monitor their use of mathematical language throughout their small-group and whole-group discussions.

Lead students in a whole-group discussion on Peaches and Plums using these guiding questions if needed:

- *Where did you place the line representing the banana? How did you know to place it there?*
- *How could you use slope triangles to show that peaches are more expensive than the other two fruits?*
- *If you have \$5 to spend on one type of fruit, how can you use the graph to show which fruit you can buy more of for your money?*

INCLUDED IN THE STUDENT MANUAL

Task #2 : Peaches and Plums

The graphs below show the cost y of buying x pounds of fruit. One graph shows the cost of buying x pounds of peaches, and the other shows the cost of buying x pounds of plums.

1. Which kind of fruit costs more per pound? Explain.
2. Bananas cost less per pound than peaches or plums. Draw a line alongside the other graphs that might represent the cost y of buying x pounds of bananas.

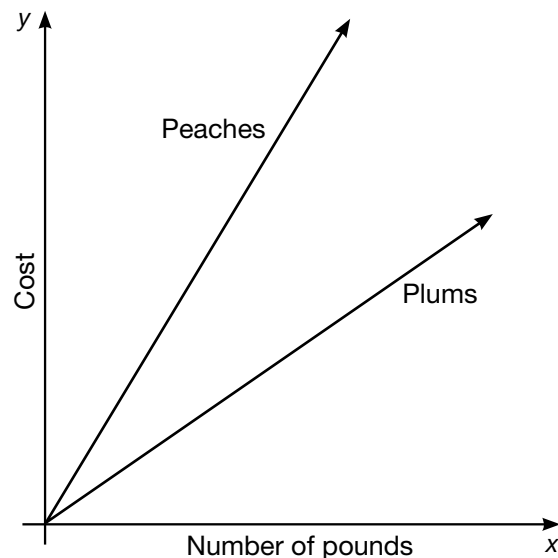

(<http://www.illustrativemathematics.org/illustrations/55>)

Commentary for the Teacher:

This task allows students to reason about the relative costs per pound of the two fruits without actually knowing the costs. Students who find this difficult may add a scale to the graph and reason about the meanings of the ordered pairs. Comparing the two approaches in a class discussion can be a profitable way to help students make sense of slope.

Possible Solutions:

The graph that represents the cost of x pounds of peaches is steeper, so it must have a larger slope. The slope can be interpreted as the unit rate; in this case it tells you the cost of a single pound of fruit.

Since the slope for the peach graph is greater than the slope of the plum graph, the cost of a pound of peaches is greater than the cost of a pound of plums.

For b, students should realize that the cost per pound of bananas will be represented by a slope that is less than either of the other two, and draw a line through the origin labeled "Bananas" lying below both of the other graphs.

Explore



Pose the questions, “In the Peaches and Plums problem, which variable is the independent variable and which is the dependent variable? Why does it make more sense for cost to be on the y-axis?” Students may also need to be asked: “Does cost depend on number of pounds or does number of pounds depend on cost?”

Use the *Independent vs. Dependent* practice if students are having trouble distinguishing between the two variables. This should only be given to all students if the majority of the class is having trouble distinguishing between the two variables, otherwise, it can be assigned to individual students as needed.

INCLUDED IN THE STUDENT MANUAL

Task #3: Independent vs. Dependent

For each situation, identify the independent and dependent variables.

1. The height of the grass in a yard over the summer.
Independent: _____
Dependent: _____
2. The number of buses needed to take different numbers of students on a field trip.
Independent: _____
Dependent: _____
3. The weight of your dog and the reading on the scale.
Independent: _____
Dependent: _____
4. The amount of time you spend in an airplane and the distance between your departure and your destination.
Independent: _____
Dependent: _____
5. The number of times you dip a wick into hot wax and the diameter of a hand-made candle.
Independent: _____
Dependent: _____
6. The amount of money you owe the library and the number of days your book is overdue.
Independent: _____
Dependent: _____
7. The number of homework assignments you haven't turned in and your grade in math.
Independent: _____
Dependent: _____
8. The temperature of a carton of milk and the length of time it has been out of the refrigerator.
Independent: _____
Dependent: _____

9. The weight suspended from a rubber band and the length of the rubber band.

Independent: _____

Dependent: _____

10. The diameter of a pizza and its cost.

Independent: _____

Dependent: _____

11. The number of cars on the freeway and the level of exhaust fumes in the air.

Independent: _____

Dependent: _____

Possible Solutions:

For each situation, identify the independent and dependent variables.

1. The height of the grass in a yard over the summer.

Independent: **The day of summer** Dependent: **Height of grass**

2. The number of buses needed to take different numbers of students on a field trip.

Independent: **Number of students** Dependent: **Number of buses**

3. The weight of your dog and the reading on the scale.

Independent: **Weight of Dog** Dependent: **Scale Reading**

4. The amount of time you spend in an airplane and the distance between your departure and your destination.

Independent: **Distance between cities** Dependent: **Time in airplane**

5. The number of times you dip a wick into hot wax and the diameter of a handmade candle.

Independent: **Number of dips** Dependent: **Diameter of candle**

6. The amount of money you owe the library and the number of days your book is overdue.

Independent: **Number of days overdue** Dependent: **Amount you owe library**

7. The number of homework assignments you haven't turned in and your grade in math.

Independent: **Number of homework assignments missing** Dependent: **Math grade**

8. The temperature of a carton of milk and the length of time it has been out of the refrigerator.

Independent: **Time out of refrigerator** Dependent: **Temperature of milk**

9. The weight suspended from a rubber band and the length of the rubber band.

Independent: **Weight suspended** Dependent: **Length of rubber band**

10. The diameter of a pizza and its cost.

Independent: **Diameter of pizza** Dependent: **Cost**

11. The number of cars on the freeway and the level of exhaust fumes in the air.

Independent: **Number of cars** Dependent: **Level of exhaust fumes**

In pairs (or groups of no more than four), students work the *Coffee by the Pound* problem. This problem will revisit unit rates, independent and dependent variables, and the meaning of slope in the context of the problem. While circulating to each group, encourage students to develop Mathematical Practice 4 by focusing on the relationship between the variables, applying that knowledge to create a mathematical model, and then assessing the reasonableness of their results.

INCLUDED IN THE STUDENT MANUAL

Task #4: Coffee by the Pound

Lena paid \$18.96 for 3 pounds of coffee.

- What is the cost per pound for this coffee?
- How many pounds of coffee could she buy for \$1.00?
- Identify the independent and dependent variables for this problem.
- Draw a graph in the coordinate plane of the relationship between the number of pounds of coffee and the price of coffee.

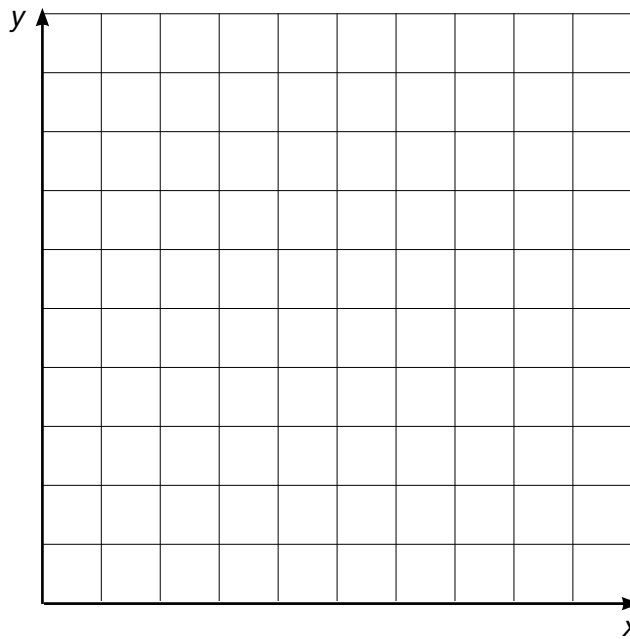

- In this situation, what is the meaning of the slope of the line you drew in part (d)?

Adapted from <http://www.illustrativemathematics.org/illustrations/129>

Commentary for the Teacher:

Although the original task does not include (c)—the identification of the independent and dependent variables, it is added here to call attention to the relationship between these variables. Linear functions in context are strongly emphasized in this unit; therefore, it is imperative that students understand how and when one variable depends on another. This particular task gives students exposure to a relation in which one variable is not clearly dependent on the other.

Possible Solutions:

- If you divide the cost for three pounds by three, you will get the cost per pound. Coffee costs \$6.32 per pound.
- If you divide the number of pounds by the cost for three pounds, you will get the amount of coffee one can purchase for \$1.00. You can buy approximately 0.16 pounds of coffee for a dollar.
- If you feel like the price of coffee depends on number of pounds, then the price of coffee is the dependent variable and number of pounds is the independent variable. However, if you feel that the number of pounds depends on the price of coffee, then the number of pounds is your dependent variable and the price of coffee is the independent variable. This is one of those cases when one variable does not clearly depend on the other.
- There are two possible graphs depending on what you choose x to represent and what you choose y to represent.

If we let x indicate the number of pounds of coffee and let y indicate the total price, then the solver may produce a graph by drawing a line through the origin and the point (3, 18.96). See below.

If we let x indicate the total price and let y indicate the number of pounds of coffee, then the solver may produce a graph by drawing a line through the origin and the point (18.96, 3).

- With the decision for x and y , the slope is the cost per pound of coffee, which is \$6.32. If we had chosen the other order, the slope would have been the amount of coffee one could buy for a dollar, which is 0.16 pounds.

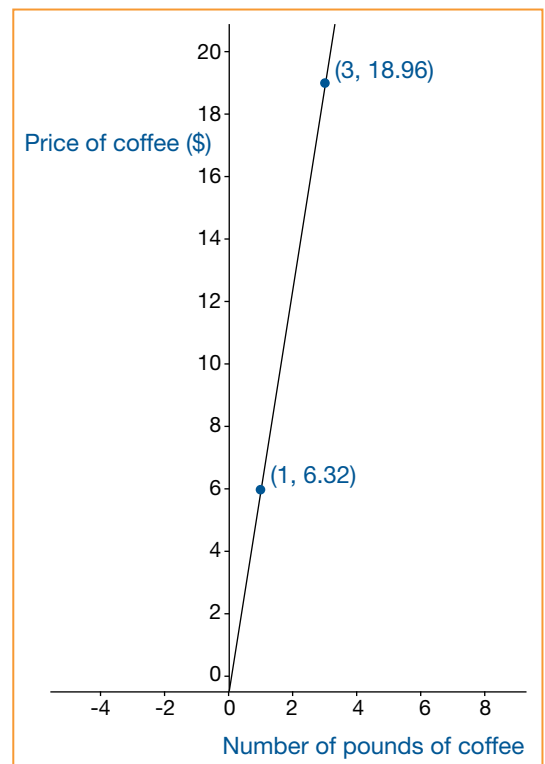

Explanation



Select one group (preferably a group that seems to have a good understanding) to present the solutions to the class on chart paper or using a document camera (if available).

Lead a whole-group discussion on *Coffee by the Pound* with special attention given to (c)—the two possible answers for independent and dependent variables, and (e)—the meaning of the slope in the context of the problem. After the solution to (c) is presented, ask the class if any other group disagrees on the independent and

dependent variables. Discuss that in some situations, one variable clearly depends on the other, but this is not always the case. Use this discussion as an opportunity to help students better understand how to identify flawed arguments and how to justify their own conclusions to others.

Practice Individually



Students will work through the problem *Who Has the Best Job?* individually. Monitor student work to check for understanding. If individual students are struggling, it may be beneficial to allow them to ask a peer in their group, “how did you get started?” after the student has had ample time to struggle on his own.

INCLUDED IN THE STUDENT MANUAL

Task #5: Who Has the Best Job?

Kell works at an after-school program at an elementary school. The table below shows how much money he earned every day last week.

	Monday	Wednesday	Friday
Time Worked	1.5 hours	2.5 hours	4 hours
Money Earned	\$12.60	\$21.00	\$33.60

Mariko has a job mowing lawns that pays \$7 per hour.

- Who would make more money for working 10 hours? Explain or show your work.
- Draw a graph that represents y , the amount of money Kell would make for working x hours, assuming he made the same hourly rate he was making last week.
- Using the same coordinate axes, draw a graph that represents y , the amount of money Mariko would make for working x hours.
- How can you see who makes more per hour just by looking at the graphs? Explain.

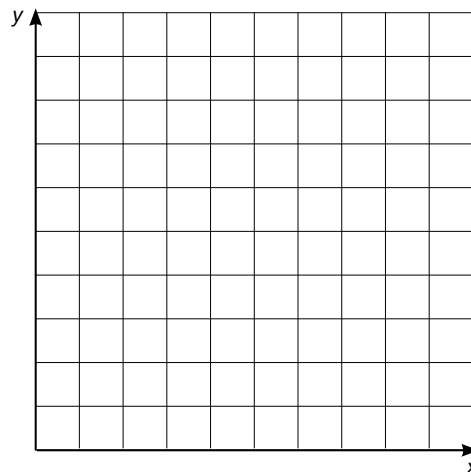

Adapted from <https://www.illustrativemathematics.org/content-standards/tasks/184>

Possible Solutions:

- Mariko would make $7 \times 10 = 70$ dollars for working 10 hours. Kell’s hourly rate can be found by dividing the money earned by the hours worked each day.

	Monday	Wednesday	Friday
Time Worked	1.5 hours	2.5 hours	4 hours
Money Earned	\$12.60	\$21.00	\$33.60
Pay Rate	\$8.40 per hour	\$8.40 per hour	\$8.40 per hour

If Kell works for 10 hours at this same rate, he will earn \$84.00. So Kell will earn more money for working 10 hours.

- See the figure to the right.
- See the figure to the right.
- You can see that Kell will make more per hour if you look at the points on the graph where $x=1$ since this will tell you how much money each person will make for working one hour. You can also compare the slopes of the two graphs, which are equal to the hourly rates. See the figure to the right.

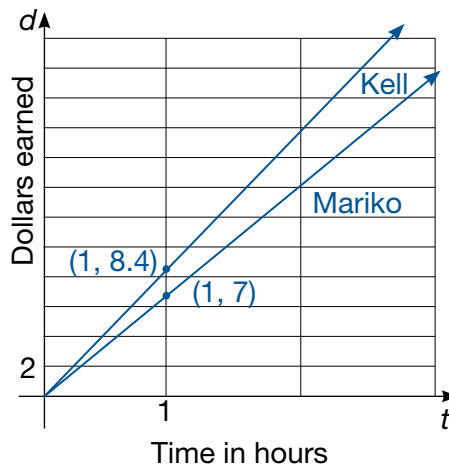

Evaluate Understanding



After completing *Who Has the Best Job?* students should share and compare their solutions to the problem with their group of four.

Engage students in a whole-group discussion centered on discrepancies, if any, in students' solutions. Encourage students to critique the reasoning of others and to construct their own viable arguments to uncover these discrepancies and bring to light students' misconceptions. Discussion questions may include:

- How does this graph compare to the graph of *Peaches and Plums*?
- What coordinate pair on the graph represents Kell's hourly rate?
- How can you tell who's hourly rate is more at $x = 2$? How can you tell who's hourly rate is more at $y = \$20$?

Closing Activity

Explain the independent practice assignment (below). Students may need to be reminded that they will need to use their graph from *Coffee by the Pound* in order to complete the assignment.

Exit ticket – “What questions do you still have about today's lesson?” Students should turn the exit ticket in before leaving class. The teacher should use this formative assessment to resolve remaining questions before the next lesson.

Independent Practice:

In this exercise, students will construct similar triangles to explain why the *Coffee by the Pound* graph has a constant slope regardless of the two points chosen to calculate. Instruct students to draw a right triangle connecting (1, 6.32) and (2, 12.64) and another right triangle connecting (1, 6.32) and (3, 18.96). (If students used price of coffee as their independent variable, their coordinate pairs will be the inverse of those previously mentioned.) Students should answer the following question using mathematics to explain their solution: “How might you use these triangles to explain why this is a linear function?”

Linear Functions

Lesson 3 of 7

Linear Equations in Context: Graphing and Describing Key Features

Description:

In this lesson, students will be asked to identify and describe key features and characteristics of linear functions in the form of an equation and graphically. They will again be asked to explain the meaning of the slope in context as well as the meaning of the intercepts. Students will see linear equations in both y -intercept and standard form and will graph the functions. Additionally, they will be asked to identify domain and range of linear functions.

Georgia Standards of Excellence Addressed:

- FMGSE8.F.4: Construct a function to model a linear relationship between two quantities. Determine the rate of change and initial value of the function from a description of a relationship or from two (x,y) values, including reading these from a table or from a graph. Interpret the rate of change and initial value of a linear function in terms of the situation it models, and in terms of its graph or a table of values.
- MGSE9-12.F.IF.7: Graph functions expressed algebraically and show key features of the graph both by hand and by using technology.
- MGSE9-12.F.IF.7a: Graph linear and quadratic functions and show intercepts, maxima and minima (as determined by the function or by context).
- MGSE9-12.S.ID.7: Interpret the slope (rate of change) and the intercept (constant term) of a linear model in the context of the data..

Standard(s) for Mathematical Practice Emphasized:

- SMP 1: Make sense of problems and persevere in solving them.
- SMP 3: Construct viable arguments and critique the reasoning of others.
- SMP 4: Model with mathematics.

Sequence of
Instruction

Activities Checklist

Engage

MATH
3
PRACTICE

Students should work with a partner on *Megan's Disney Vacation*.

INCLUDED IN THE STUDENT MANUAL

Task #6: Megan's Disney Vacation

Megan and her family are travelling from their home in Nashville, TN to Orlando, FL on a Disney vacation. The trip is 685 miles and they will be travelling 65 miles per hour, on average.

Megan used the following equation to calculate the remaining distance throughout the trip:

$$D=685-65h$$

Discuss the following with your partner:

- The intercepts and slope and the meaning of each in the context of the problem.
- The independent and dependent variables.
- The domain and range.

Examine the graph of the equation below. What steps might you take to graph this equation? By studying the graph, where do you see the components of the graph mentioned above?

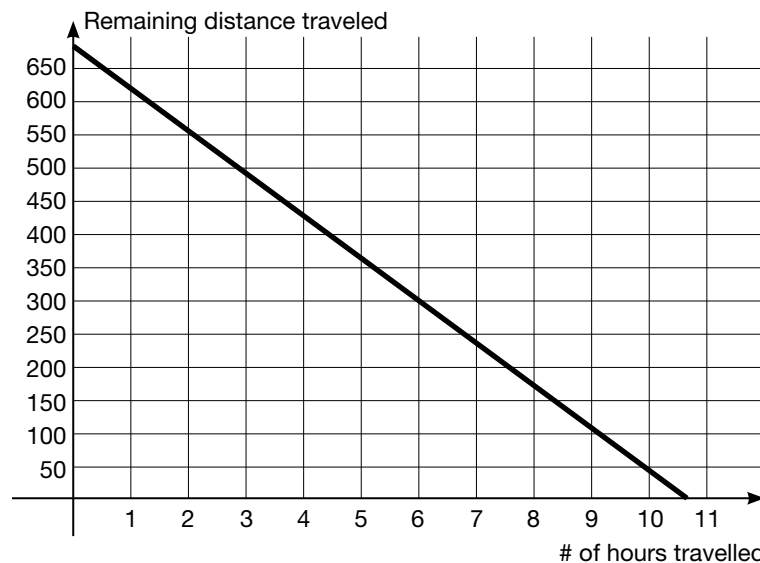

Possible Solutions:

- The y-intercept (0, 685) represents the travelling distance that remains before Megan's family starts the trip. Therefore, the y-intercept is the total distance of the trip. The x-intercept is approximately (10.5, 0) which represents the amount of time it took Megan's family to travel from Nashville to Orlando. The slope is -65. In this case, 65 is the average speed in which the family is travelling. The negative value for the slope indicates that the total remaining distance is decreasing by 65 for each hour they travel.
- The remaining distance of the trip depends on the number of hours the family has travelled. Therefore, the remaining distance is the dependent variable and the number of hours travelled is the independent variable.
- The domain is $0 \leq h \leq 10.5$ which is the number of hours the family travelled. The range is the remaining distance which is $0 \leq D \leq 685$.
- Because you know both the x and the y-intercepts, you could plot those points and simply connect them to graph the line. You also know the slope so you could plot the y-intercept and then plot additional points using the slope.
- You can see the x-intercept on the x-axis at the point (10.5, 0). Likewise, the y-intercept can be found at (0, 685). The negative slope indicates that the remaining distance is decreasing as the number of hours travelled increases. More specifically, for every hour travelled, the remaining distance decreases by 65.

While circulating the classroom, take particular notice of ways in which students explain procedures for graphing and where they see the components/characteristics of the graph on the one provided. Understanding the context of the problem is important for the upcoming activity so make sure students are able to communicate in the context of the problem. Guiding questions may include:

- *How many miles are remaining at the beginning of the trip? Where do you see this represented on the graph?*
- *What might the point on the x-axis between 10 and 11 represent? How does this correlate to the equation provided?*
- *What questions might you ask to determine which variable is independent and which is dependent?*
- *What information could be useful in order to graph the function?*

Throughout this activity, students should be making plausible arguments to their partner that take the context of the data into account. Summarize this activity with a whole-group discussion focusing on common mistakes or misconceptions while also encouraging students to justify their conclusions with mathematical language.

Explore



Give each pair of students a set of *Matching Equations, Graphs, and Their Characteristics* cards. Students should take turns matching a graph, equation, and characteristics card to make a set of three cards. With each match that is made, the student should explain to their partner why those cards were matched together. Listen very carefully to students through this process in order to assure they are providing sound, mathematical arguments to justify their matches. At this same time, students are making sense of problems by analyzing and explaining relationships between the key characteristics of linear functions displayed in various ways. Notice the set includes three blank cards that students should fill in to make six complete sets of three.

While circulating the classroom, utilize good questioning without leading students directly to correct matches. Some sample questions are as follows:

- *What do you know about this graph? Where does the graph of this line intersect the axes?*
- *What is similar about all the points on the x-axis? On the y-axis?*
- *How can you tell if a line has a negative or a positive slope?*
- *What steps must you take in order to change the equation (in standard form) to slope-intercept form?*

For students who are struggling, ask them to first only look at the equations in y-intercept form to identify the slope and y-intercept. Then they can match those to the appropriate characteristics and graphs. It may also help in narrowing down choices to look at the x-intercept and y-intercept characteristics cards and try to match those to remaining graphs with the same intercepts. Some students will likely need assistance with identifying characteristics of functions written in standard form.

This matching activity serves to reinforce student understanding of linear equations and their graphs in preparation for graphing linear equations within a context. Summarize this activity with a brief whole-group discussion focused on aspects of the activity in which students struggled.

Practice Together in Small Groups



Display these directions for the class to view while working on the *Graphing Linear Equations in Context* activity.

For each situation, identify the following and then graph the equation on graph paper (use a graphing calculator to check your work):

1. Slope and any intercepts and explain what each means in the context of the problem.
2. Independent and dependent variables.
3. Domain and range.

Cut the *Graphing Linear Equations in Context* activity into cards to be handed out to student groups of three or four, **one at a time**, as they complete each one. Groups may work at their own pace completing as many cards as possible within the allotted time.

Copy one set of cards for each group although not all groups may complete the set. Begin by handing each group a different card. (Students will later present their work and each problem should be represented in the presentation. For this reason, it may make sense to give an easier problem to students who struggle more first.)

Each group should complete at least two cards. For struggling students, make sure they get exposure to cards with both slope-intercept and standard forms. The following sample guiding questions may support deeper understanding:

- *Are there any constraints in the problem? If so, what are they?*
- *How can you identify slope in a word problem?*
- *What are the variables in the situation? Which variable depends on the other?*
- *What is represented by the coefficient of x (or y) in the equation?*

Throughout this activity, students will exercise modeling mathematics and analyzing relationships to draw conclusions within the given context.

Evaluate Understanding

Assign each group a card to present. Students should display their graph on chart paper or use a document camera so that all students can see as they present their solutions.

Each student must play a part in presenting and explaining their solutions. Thoughtful questions should be prepared to ask the presenting groups but is based on their understandings and misconceptions revealed during the activity. It is especially important to listen to groups as they work in order to determine the questions that are imperative to ask.

While groups are preparing their presentation, the teacher could write questions for presenters on post-it notes and hand out to various other groups to later ask presenters.

If handed a question to ask, that group must discuss the question prior to asking it of the presenters. This allows the discussion to be more student-centered and frees the teacher to focus on assessing student understanding. The following are types of questions that could be given to groups to ask presenters:

- *How did you know that the number of miles driven should go on the x-axis?*
- *Why did you connect the points on the graph?*
- *What if I got a different answer for my independent and dependent variables?*

Closing Activity

Engage students in a brief, whole-group discussion highlighting the major points of the lesson. From the previous activity, the following questions could be asked:

- *What is the difference in the information provided in standard form and slope-intercept form?*
- *If given an equation in standard form could it be changed to slope-intercept form to graph? When might you want to change from standard to slope-intercept form and when would it make more sense to leave it alone?*

Exit ticket: Graphing in Context should be used to gauge students' level of understanding of slope and y-intercept in context and graphing linear equations. For students still struggling with these concepts, additional practice will need to be incorporated throughout upcoming lessons as this lesson serves as a foundation for the remainder of the unit.

Independent Practice:

A car is traveling down a long, steep hill. The elevation, E , above sea level (in feet) of the car when it is d miles from the top of the hill is given by $E = 7500 - 250d$, where d can be any number from zero to six. Find the slope and intercepts of the graph of this function and explain what they mean in the context of the moving car.

Additional problems may need to be added based on student needs.

Resources/Instructional Materials Needed:

Graphing calculator

Notes:

Linear Functions

Matching Equations, Graphs and Their Characteristics: Student Cards

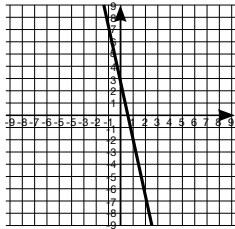
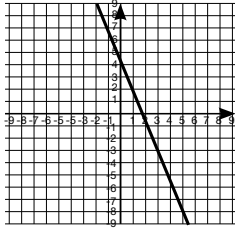
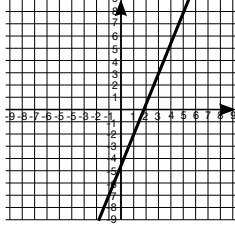
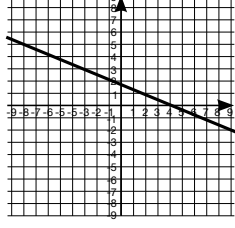
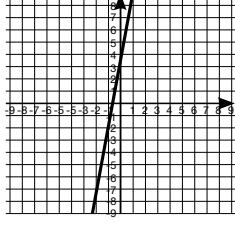
A $y = \frac{5}{2} - 5x$	G Slope: -5 y-intercept: 2.5	M 
B $y = -2.5x + 5$	This is a blank student card student will fill in.	L 
C $2.5x - y = 5$	F x-intercept: (2, 0) y-intercept: (0, -5)	O 
D $2x + 5y = 10$	I x-intercept: (5, 0) y-intercept: (0, 2)	N 
E $2x - 5y = 10$	J Slope: 2/5 y-intercept: -2	This is a blank student card student will fill in.
This is a blank student card student will fill in.	H Slope: 5 y-intercept: 2.5	K 

Linear Functions

Graphing Linear Equations in Context

Rather than drive to the gym, Jaylen decides he can burn more calories by jogging to the gym and then completing his workout on the bicycle. Jaylen burns 133 calories jogging to the gym. Once there, he burns 10 calories per minute cycling.

$$T=133+10n$$

To clean out her new 120-gallon fish tank, Erika purchased a water pump that will siphon out three gallons of water every minute.

$$G=120-3m$$

The Alpha Airline Company allows passengers two bags with a total weight of 100 pounds.

$$x+y=100$$

Taxi companies in Chicago typically charge an initial fee of \$2.25 and \$1.80 for each mile.

$$T=1.80m+2.25$$

The current rate of exchange for U.S. dollars to Mexican Pesos is approximately \$1 per 13 pesos.

$$P=13D$$

Sherri owed her sister \$450. She decided if she paid her sister a set amount each month, she could pay her back in 6 months and then continue to pay that same amount monthly into a savings account.

$$75x-y=450$$

Jason's summer job allowed him to save \$1200 to use as spending money throughout the upcoming school year. To make sure he has enough money, Jason plans to spend the same amount each month and not run out of money until the end of the school year in 10 months.

$$120x+y=1200$$

The current world population is approximately seven billion and is growing at a rate of approximately 73 million per year.

$$y=7,000,000,000+73,000,000x$$

Exit Ticket: Graphing in Context: Teacher Solutions

INCLUDED IN THE STUDENT MANUAL

Exit Ticket: Graphing in Context

Carole owns a t-shirt company where she both designs and produces t-shirts for local individuals and businesses. Carole paid \$18,000 for the printing machine and it costs an additional \$5 for each t-shirt produced. An equation to model this situation is below:

$$C = 18,000 + 5t$$

1. What is the y-intercept and what does it mean in the context of this problem?
2. What is the slope and what does it mean in the context of this problem?
3. Graph the equation.

Possible Solutions:

1. What is the y-intercept and what does it mean in the context of this problem?
\$18,000 is the y-intercept. This is the cost of Carole's printing machine.
2. What is the slope and what does it mean in the context of this problem?
The slope is 5; for each shirt cost \$5 to be made.
3. Graph the equation.

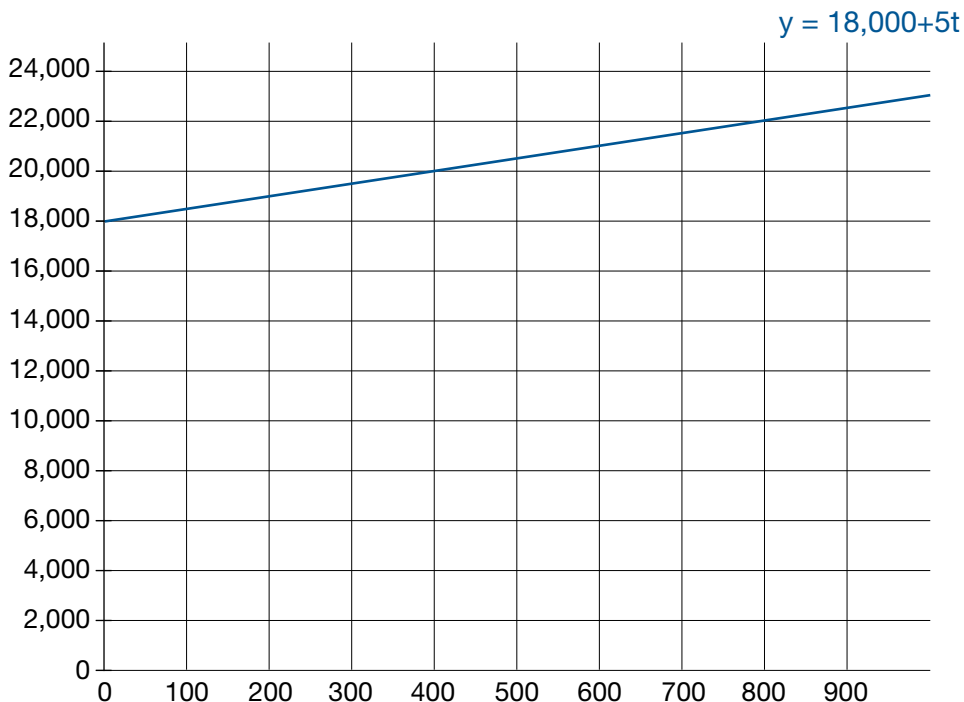

Linear Functions

Lesson 4 of 7

Writing Equations of Lines

Description:

Students will now turn their attention towards writing equations of lines given various pieces of information. Once they have practiced writing equations given two points, students will revisit the iTunes app problem and will write an equation for the data collected during the hook. Students will then write several equations given different situations. They must identify the slope and any intercepts as well as explaining these features in the context of the problem.

Georgia Standards of Excellence Addressed:

- MGSE8.F.4: Construct a function to model a linear relationship between two quantities. Determine the rate of change and initial value of the function from a description of a relationship or from two (x,y) values, including reading these from a table or from a graph. Interpret the rate of change and initial value of a linear function in terms of the situation it models, and in terms of its graph or a table of values.
- MGSE9-12.A.CED.2: Create linear, quadratic, and exponential equations in two or more variables to represent relationships between quantities; graph equations on coordinate axes with labels and scales. (The phrase “in two or more variables” refers to formulas like the compound interest formula, in which $A = P(1 + r/n)^{nt}$ has multiple variables.)
- MGSE9-12.S.ID.7: Interpret the slope (rate of change) and the intercept (constant term) of a linear model in the context of the data.

Standard(s) for Mathematical Practice Emphasized:

- PSMP 4: Model with mathematics.
- SMP 6: Attend to precision.

Sequence of
Instruction

Activities Checklist

Engage

To introduce the lesson, remind students of the iTunes 25 billion apps countdown from Lesson 1 and post the table of data and the graph below for students to view. It will be helpful to have the video from Lesson 1 playing through this part of the lesson so that students can see the date and time in which the video was created (<http://vimeo.com/37382647>). Pose the question: *How might this data help to predict the day of the 25 billionth download?*

Time(s)	# on Counter
0	24,658,491,600
10	24,658,497,385
20	24,658,503,379
30	24,658,508,754
40	24,658,514,729
50	24,658,520,201
60	24,658,525,886
70	24,658,531,626
80	24,658,537,338
90	24,658,543,074

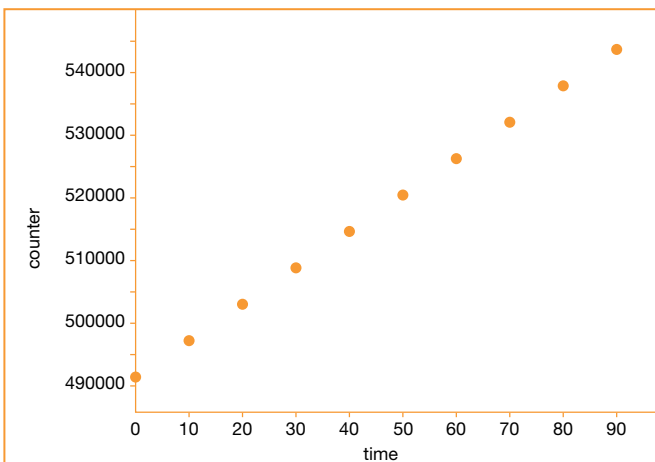

Allow students to discuss briefly in their groups. Hopefully, after having worked recently with equations and graphs in context, students will suggest that an equation could be created from the data. Here are some suggested questions to guide the discussion:

- *Does anyone remember how we can use data to write an equation?*
- *Once we have an equation, what might we do to make our prediction?*
- *What other information is needed in order to make the prediction?*

This discussion serves to set up the current lesson on writing equations but also is a precursor to Lessons 6 and 7 where students will be calculating a line of best fit.

Explanation

For the next activity, students will use the iTunes data to write an equation, however, students will likely need a mini-lesson first on how to write an equation from a set of data. They will need to be reminded of both slope formula, point-slope formula, and rearranging point-slope into slope-intercept form. The amount of time for this mini-lesson depends greatly on students' level of understanding. It is not reasonable to go on to the iTunes problem before students can write an equation with minimal assistance.

Below are some possible practice problems to use for the mini-lesson.

Write an equation of the line in slope-intercept form that passes through the points:

- $(-2, -1)$ and $(5, 13)$
- $(-1, 5)$ and $(3, 1)$
- $(0, -3)$ and $(5, -5)$

Explore



Students will now use the data from the table (or your own data you may have collected) to write an equation that models the iTunes app promotion, requiring students to exercise the use of Process Readiness Indicator 4. (In the culminating task, students will collect their own data and write an equation from that data, but for now, the focus is simply on writing an equation from a given set of data.)

Ask students to graph the data, write an equation to model it, and then interpret both the slope and y-intercept in the context of the problem. As part of modeling with mathematics, students not only interpret results in context but also reflect on the reasonableness of those results. Students may consult with their group members but should do their own individual work so you can more accurately determine which students are struggling with the process. This task will require students to attend to precision as they determine an appropriate scale for their axes. They must also select an appropriate degree of precision relative to the problem context when writing the equation.

Time(s)	# on Counter
0	24,658,491,600
10	24,658,497,385
20	24,658,503,379
30	24,658,508,754
40	24,658,514,729
50	24,658,520,201
60	24,658,525,886
70	24,658,531,626
80	24,658,537,338
90	24,658,543,074

Students will arrive at slightly different equations given that the data is not perfectly linear. This would be a good time to have a quick discussion on what might have caused different groups to attain different equations. Have students display their different equations on a graphing calculator and see how close they really are.

Practice Together in Small Groups



Students should work in pairs or small groups on *Writing Linear Equations in Context*. (An alternative would be to turn this into a Sage-and-Scribe activity. Students would work in pairs, but only one student records the solutions while the partner talks through the problem. This would help assure accountability amongst all students.)

INCLUDED IN THE STUDENT MANUAL

Task #7: Writing Linear Equations in Context

For each of the situations determine the slope, y-intercept, and x-intercept, along with each of their real-world meanings, when applicable. Additionally, write an equation to model the situation. Each equation should be written in the form most appropriate for the information provided.

1. To prepare for a recent road trip, Jill filled up her 19-gallon tank. She estimates that her SUV will use about three gallons per hour. Write an equation to model the amount of gasoline, G , remaining in her tank after t hours.

2. Roberto deposits the same amount of money each month into a checking account. Use the table to write an equation to model his balance, B , after m months.

# of months	1	3	6
Balance	255	365	530

3. Let f be the function that assigns to a temperature in degrees Celsius its equivalent in degrees Fahrenheit. The freezing point of water in degrees Celsius is zero while in degrees Fahrenheit it is 32. The boiling point of water is 100 degrees Celsius and 212 degrees Fahrenheit. Given that the function f is linear, use this information to find an equation for f .

4. At the beginning of October, Monique changed banks and decided to leave the remaining \$3900 in her old checking account to pay for rent. After six months, her balance was finally zero. If the balance, B , in Monique's account is a function of time, t , write an equation for the situation.
5. On a recent scuba diving trip, Kate and Kara reached a depth of 130 feet. Six-and-a-half minutes later after ascending at a constant rate, they reached the surface. Write an equation to represent their distance, D , as a function of time, t .

These problems focus on students not only being able to write linear equations but must also understand the slope and intercepts within the context of the problem.

As a summarizing discussion for this activity, the teacher could revisit domain and range. Also, this would be a good opportunity to look at the graph, tables and equations of the functions on a graphing calculator for discussion.

Possible Solutions:

For each of the situations determine the slope, y-intercept, and x-intercept, along with each of their real-world meanings, when applicable. Additionally, write an equation to model the situation. Each equation should be written in the form most appropriate for the information provided.

1. To prepare for a recent road trip, Jill filled up her 19-gallon tank. She estimates that her SUV will use about three gallons per hour. Write an equation to model the amount of gasoline, G , remaining in her tank after t hours.

Slope: *-3 gallons per hour*

Real-world meaning: *Every hour, Jill uses 3 gallons of gas.*

y-intercept: *19 gallons*

Real-world meaning: *Jill started her trip with 19 gallons of gas.*

x-intercept: *6.33 hours*

Real-world meaning: *After 6 and 1/3 hours, Jill will be out of gas.*

Equation: $G=19 - 3t$

2. Roberto deposits the same amount of money each month into a checking account. Use the table to write an equation to model his balance, B , after m months.

Slope: *55 dollars per month*

Real-world meaning: *Roberto deposits \$55 monthly.*

y-intercept: *\$200*

Real-world meaning: *Roberto opened his account with an initial deposit of \$200.*

x-intercept: *-(200/55) or -3.63 months*

Real-world meaning: *This x-intercept does not have real world-applications as it would represent the month for which Roberto had a 0 balance.*

Equation: $B = 200 + 55m$

3. Let f be the function that assigns to a temperature in degrees Celsius its equivalent in degrees Fahrenheit. The freezing point of water in degrees Celsius is zero while in degrees Fahrenheit it is 32. The boiling point of water is 100 degrees Celsius and 212 degrees Fahrenheit. Given that the function f is linear, use this information to find an equation for f .

Slope: $9/5$ (or 1.8) degrees

Real-world meaning: *Every 1° increase in Celsius results in a 1.8° change in a Fahrenheit recording of the same temperature.*

y-intercept: 32 degrees

Real-world meaning: *The Fahrenheit scale starts 32° above the Celsius scale.*

x-intercept: -17.778 degrees

Real-world meaning: *This is the Celsius degree for a 0° Fahrenheit.*

Equation: $f = (9/5)C + 32$

4. At the beginning of October, Monique changed banks and decided to leave the remaining \$3900 in her old checking account to pay for rent. After six months, her balance was finally zero. If the balance, B , in Monique's account is a function of time, t , write an equation for the situation.

Slope: -650 dollars/month

Real-world meaning: *Monique's account decreased by \$650 monthly; thus, her monthly rent was \$650.*

y-intercept: \$3900

Real-world meaning: *The amount of money left in Monique's checking account.*

x-intercept: 6 months

Real-world meaning: *The number of months it took Monique to deplete her account.*

Equation: $B = 3900 - 650t$

5. On a recent scuba diving trip, Kate and Kara reached a depth of 130 feet. Six-and-a-half minutes later after ascending at a constant rate, they reached the surface. Write an equation to represent their distance, D , as a function of time, t .

Slope: -20 feet per minute

Real-world meaning: *Every minute Kate and Kara climb 20 feet closer to the surface. The negative sign indicates movement toward the surface at $y=0$.*

y-intercept: 130 feet

Real-world meaning: *This is the maximum depth Kate and Kara reached. They turned around at this point and headed back towards the surface at $y=0$.*

x-intercept: 6.5 minutes

Real-world meaning: *It took Kate and Kara 6.5 minutes to return to the surface of the water from a depth of 130 feet.*

Equation: $D = 130 - 20t$

Evaluate Understanding

More Modeling with Functions

These problems could be used in a variety of ways including, but not limited to:

- Extra practice problems for all.
- Enrichment for advanced learners.
- Quiz to check for understanding.

INCLUDED IN THE STUDENT MANUAL

Task #8: More Modeling with Functions

1. A student has had a collection of baseball cards for several years. Suppose that B , the number of cards in the collection, can be described as a function of t , which is time in years since the collection was started. Explain what each of the following equations would tell us about the number of cards in the collection over time.
 - (a) $B = 200 + 100t$
 - (b) $B = 100 + 200t$
 - (c) $B = 2000 - 100t$
 - (d) $B = 100 - 200t$
2. Which of the following could be modeled by $y = 2x + 5$? Answer YES or NO for each one.
 - (a) There are initially five rabbits on the farm. Each month thereafter the number of rabbits is two times the number in the month before. How many rabbits are there after x months?
 - (b) Joaquin earns \$2.00 for each magazine sale. Each time he sells a magazine he also gets a five-dollar tip. How much money will he earn after selling x magazines?
 - (c) Sandy charges \$2.00 an hour for babysitting. Parents are charged \$5.00 if they arrive home later than scheduled. Assuming the parents arrived late, how much money does she earn for x hours?
 - (d) I have a sequence of integers. The first term of the sequence is 7 and the difference between any consecutive terms is always equal to two.
 - (e) Sneak Preview is a members-only video rental store. There is a \$2.00 initiation fee and a \$5.00 per video rental fee. How much would John owe on his first visit if he becomes a member and rents x videos?
 - (f) Andy is saving money for a new CD player. He began saving with a \$5.00 gift and will continue to save \$2.00 each week. How much money will he have saved at the end of x weeks?
3. A checking account is set up with an initial balance of \$4800, and \$400 is removed from the account each month for rent (no other transactions occur on the account).
 - (a) Write an equation whose solution is the number of months, m , it takes for the account balance to reach \$2000.
 - (b) Make a plot of the balance after m months for $m=1,3,5,7,9,11$ and indicate on the plot the solution to your equation in part (a).

Closing Activity

Assist students in creating a tri-fold graphic organizer to help them remember the procedures for writing linear equations, given various information.

Journal Entry: Provide students with a graph and ask them to write a story to match the graph. They must identify the slope and intercepts and explain their real-world meaning.

Independent Practice

Additional problems may be necessary depending on student needs.

INCLUDED IN THE STUDENT MANUAL

Independent Practice

Write an equation to model each of the situations.

1. Cedric and Josh both ordered the same size pizzas at Marco's Pizzeria; however, they ordered different toppings. Marco's charges an additional fee for toppings, but all toppings cost the same. Cedric got pepperoni, banana peppers, and black olives on his pizza for a cost of \$15.74. Josh ordered mushrooms and eggplant on his pizza and paid \$14.49. Using this information, write an equation for the cost of a pizza, C , as a function of the number of toppings, t ordered.
2. College tuition at Bedrock University has increased \$500 per year for the past six years. Wilma is a freshmen this year and paid \$10,250 for her tuition. She is curious about her tuition in the coming years and needs this information as motivation to graduate in four years. Assuming the tuition rate increase remains constant, write an equation to represent the tuition at Bedrock University in x years.
3. Moche started a summer business of mowing lawns. However, before he could mow lawns, he needed to purchase supplies (a lawnmower among other needs). Moche spent \$395 gathering necessary materials. He makes on average \$60 per lawn, mowed. Write an equation to show Moche his earnings for l lawns mowed.
4. Margaret purchased a new bar of soap. Three days after she originally used the soap, she was curious how much soap per day she was using. She decided to weigh her soap and found that the bar was 103 grams. Four days later she re-measured the same bar of soap and recorded a weight of 80 grams. Assuming that Margaret uses the same amount of soap daily (and that she used the soap daily), write an equation that shows the amount of soap remaining after d days of use.

Possible Solutions:

Write an equation to model each of the situations.

1. Cedric and Josh both ordered the same size pizzas at Marco’s Pizzeria; however, they ordered different toppings. Marco’s charges an additional fee for toppings, but all toppings cost the same. Cedric got pepperoni, banana peppers, and black olives on his pizza for a cost of \$15.74. Josh ordered mushrooms and eggplant on his pizza and paid \$14.49. Using this information, write an equation for the cost of a pizza, C , as a function of the number of toppings, t ordered.

$$C = 11.99 + 1.25t$$

2. College tuition at Bedrock University has increased \$500 per year for the past six years. Wilma is a freshmen this year and paid \$10,250 for her tuition. She is curious about her tuition in the coming years and needs this information as motivation to graduate in four years. Assuming the tuition rate increase remains constant, write an equation to represent the tuition at Bedrock University in x years.

$$T = 10,250 + 500t \text{ where } t \text{ is time since your freshmen year.}$$

3. Moche started a summer business of mowing lawns. However, before he could mow lawns, he needed to purchase supplies (a lawnmower among other needs). Moche spent \$395 gathering necessary materials. He makes on average \$60 per lawn, mowed. Write an equation to show Moche his earnings for l lawns mowed.

$$m = 60l - 395$$

4. Margaret purchased a new bar of soap. Three days after she originally used the soap, she was curious how much soap per day she was using. She decided to weigh her soap and found that the bar was 103 grams. Four days later she re-measured the same bar of soap and recorded a weight of 80 grams. Assuming that Margaret uses the same amount of soap daily (and that she used the soap daily), write an equation that shows the amount of soap remaining after d days of use.

$$S = 120.25 - 5.75d$$

Notes:

Linear Functions

Lesson 5 of 7

Formative Assessment Lesson: Lines and Linear Equations

Description:

Students will complete the formative assessment lesson Lines and Linear Equations from the Shell Center. This lesson will assess students' understanding of slope and their ability to translate between linear equations and their graphs.

Georgia Standards of Excellence Addressed:

- EMGSE8.EE.5 Graph proportional relationships, interpreting the unit rate as the slope of the graph. Compare two different proportional relationships represented in different ways. For example, compare a distance-time graph to a distance-time equation to determine which of two moving objects has greater speed.
- MGSE8.EE.6 Use similar triangles to explain why the slope m is the same between any two distinct points on a non-vertical line in the coordinate plane; derive the equation $y = mx$ for a line through the origin and the equation $y = mx + b$ for a line intercepting the vertical axis at b .
- MGSE8.F.1: Understand that a function is a rule that assigns to each input exactly one output. The graph of a function is the set of ordered pairs consisting of an input and the corresponding output.
- MGSE8.F.2: Compare properties of two functions each represented in a different way (algebraically, graphically, numerically in tables, or by verbal descriptions). For example, given a linear function represented by a table of values and a linear function represented by an algebraic expression, determine which function has the greater rate of change.
- MGSE8.F.3: Interpret the equation $y = mx + b$ as defining a linear function whose graph is a straight line; give examples of functions that are not linear. For example, the function $A = s^2$ giving the area of a square as a function of its side length is not linear because its graph contains the points $(1, 1)$, $(2, 4)$ and $(3, 9)$, which are not on a straight line.

Standard(s) for Mathematical Practice Emphasized:

- SMP 2: Reason abstractly and quantitatively.
- SMP 4: Model with mathematics.
- SMP 7: Look for and make use of structure.

The following *Formative Assessment Lesson* is a classroom-ready lesson included to help teachers assess and improve students' understanding of mathematical concepts and skills and their ability to use the "mathematical practices" described in the College Readiness Standards.

Research has shown that formative assessment, as embodied in the following lesson, is a powerful way to improve student learning and performance. This approach first allows students to demonstrate their prior understandings and abilities in employing the mathematical processes, and then resolve their own difficulties and misconceptions through structured discussion. This results in more secure long-term learning, reducing the need for re-teaching that otherwise takes so much classroom time.

Many often ask, why don't students just remember the procedures they have been taught and practiced? The fact is, that approach works fine in the short term but, as every teacher knows, if procedural knowledge is not underpinned by conceptual understanding, students will quickly forget "how to do it."

Read more about the *Formative Assessment Lesson* rationale, structure, and philosophy using the *Brief Guide for Teachers and Administrators* that can be found at <http://map.mathshell.org/materials/index.php>.

CONCEPT DEVELOPMENT

Mathematics Assessment Project
CLASSROOM CHALLENGES
A Formative Assessment Lesson

Lines and Linear Equations

Mathematics Assessment Resource Service
University of Nottingham & UC Berkeley
Beta Version

For more details, visit: <http://map.mathshell.org>
© 2012 MARS, Shell Center, University of Nottingham
May be reproduced, unmodified, for non-commercial purposes under the Creative Commons license
detailed at <http://creativecommons.org/licenses/by-nc-nd/3.0/> - all other rights reserved

BEFORE THE LESSON

Assessment task: *The Race* (20 minutes)

Have the students complete this task, in class or for homework, a few days before the formative assessment lesson. This will give you an opportunity to assess the work, and find out the kinds of difficulties students have with it. You will then be able to target your help more effectively in the next lesson.

Give each student a copy of the assessment task *The Race*.

Read through the questions and try to answer them as carefully as you can.

It is important that, as far as possible, students are allowed to answer the questions without your assistance.

Students should not worry too much if they cannot understand or do everything because in the next lesson they will engage in a similar task, which should help them. Explain to students that, by the end of the next lesson, they should expect to answer questions such as these confidently. This is their goal.

Assessing students' responses

Collect students' responses to the task and note down what their work reveals about their current levels of understanding, and their different approaches.

We suggest that you do not score students' work. The research shows that this will be counterproductive, as it will encourage students to compare their scores and distract their attention from what they can do to improve their mathematics.

Instead, help students to make further progress by summarizing their difficulties as a list of questions. Some suggestions for these are given in the *Common issues* table on the next page. We suggest that you make a list of your own questions, based on your students' work, using the ideas on the following page. We recommend you:

- write one or two questions on each student's work, or
- give each student a printed version of your list of questions, highlighting the questions relevant to individual students.

If you do not have time to do this, you could select a few questions that will be of help to the majority of students and write these on the board when you return the work to the students.

The Race

Maggie and Emma race each other along a straight running track. Maggie starts some distance ahead of Emma. The graph describes the race.

1. After five seconds, who is running the fastest? Explain your answer.

2. Emma's line can be represented by the equation: $s = 5t$ s is the distance, in yards, from the Starting Place. t is the time, in seconds, from the start of the race. What is the equation that represents Maggie's line?

3. Describe what happens in the race.

The diagram below shows the distance a runner is from the Starting Place and from the Finishing Line.

4. The following equation can also be used to describe Emma's race: $f = -5t + 70$ f is the distance, in yards, from the **Finishing Line**. t is the time, in seconds, from the beginning of the race.

a. Plot this line on the graph.

b. Add a line to the graph that represents Maggie's race.

c. What is the equation of this second line?

Common issues:	Suggested questions and prompts:
<p>Student assumes Maggie is running the fastest because at five seconds her line is above Emma's line (Q1.)</p>	<ul style="list-style-type: none"> • During the race, does Emma's or Maggie's speed change? • How can you figure out the speed of each runner?
<p>Students description of the race is limited For example: The student does not mention speed, or the time it took for each person to complete the race.</p>	<ul style="list-style-type: none"> • What more can you tell me about the race? • Does one runner overtake the other one? If so, at what point does this happen? • Who wins the race? How far ahead are they when they cross the finishing line? • What are the race times for each runner?
<p>Student misinterprets the scale For example: The student fails to notice the distance goes up in 5s not 1s (Q1.) Or: The student does not notice the scales for the axes on the two graphs are different.</p>	<ul style="list-style-type: none"> • What is the scale on the vertical/horizontal axis for each graph?
<p>Student draws an incorrect graph (Q4) For example: The student draws a graph with a positive slope. Or: The student draws a slope with an incorrect y-intercept, e.g. $f = 30$. Or: The student draws a non-linear graph. Or: The student draws an incomplete graph.</p>	<ul style="list-style-type: none"> • As the race progresses will the distance, f, increase or decrease? How can you show this on your graph? • At the beginning of the race, how far are the runners from the finishing line? How can you show this on your graph? • Does Maggie run at a constant speed? How have you shown this speed on your graph? • Your graph should represent all of the race. When will Emma/Maggie have completed the race? How can you show these points on the graph?
<p>Student's equations are incorrect For example: The student writes an equation without a variable for the time.</p>	<ul style="list-style-type: none"> • Explain your equation in words. • Does your equation describe how the distance changes as the race progresses?

SUGGESTED LESSON OUTLINE

Whole-class introduction (20 minutes)

Give each student a mini-whiteboard, a pen, and an eraser.

If you have a real model of two identical containers connected at the neck then use it throughout the introduction to demonstrate the liquid flow. If there is liquid in the top container then, to ensure the smooth flow of liquid, there needs to be a hole in the base of this top container.

Show the class Slide P-1 of the projector resource.

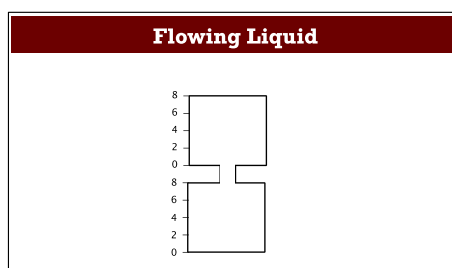

Explain to the class that the top and bottom containers are two identical right rectangular prisms. Liquid flows from the top to the bottom. The total height of liquid in both the containers is 6 units.

If the height of the liquid in the top right rectangular prism is 4 units, what is the height of the liquid in the bottom right rectangular prism? [2 units.]

At what height will there be equal amounts of liquid in the top and bottom prisms? [When there are 3 units of liquid in each prism.]

Now show Slide P-2 of the projector resource.

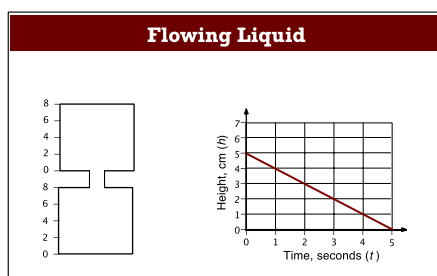

Ask students to describe in detail on their mini-whiteboards the flow of the liquid.

After a few minutes ask students to show you their whiteboards. Ask two or three students with different descriptions to explain them. Encourage the rest of the class to challenge, or add to, these descriptions.

To make sure students understand the context of the task, ask the following questions:

*Does the graph show the flow of liquid out of the top or into the bottom prism? [Top.]
How do you know?*

What is the starting situation? [5 units of liquid in the top prism, 1 unit of liquid in the bottom prism.]

*Does the liquid flow at a constant speed? [Yes.]
How do you know? [The slope is a straight line.]*

*What speed does the liquid flow at? [1 cm per second.]
How do you know?*

Then show the sequence of slides P-3 to P-8. This visualization of the flow of liquid between the prisms should help students understand the context.

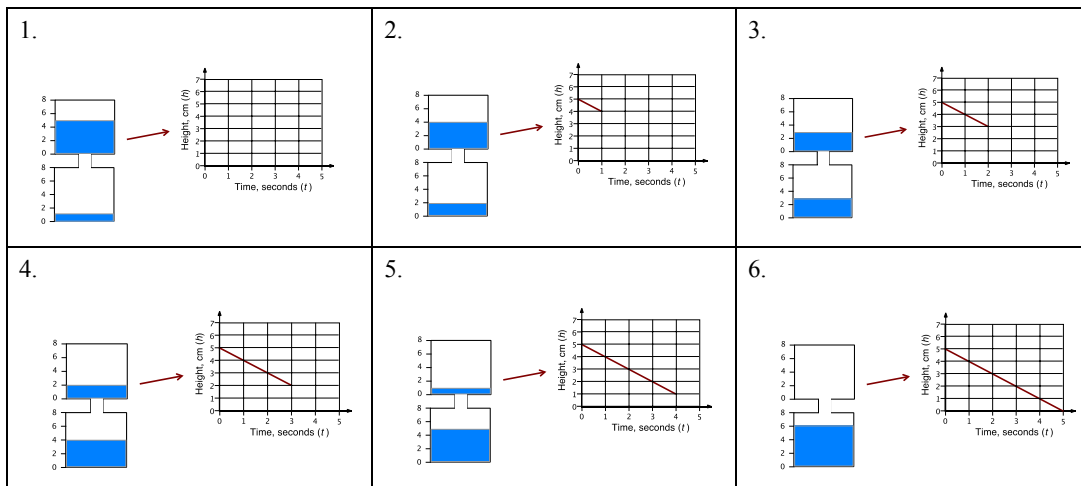

You may then want to ask further questions:

How can you change the starting situation so the liquid flows out in half the time? [Set the start height to 2.5 units, or double the speed of the flow of liquid, or increase the opening between the two prisms.]

How can you change the starting situation so the liquid flows out in double the time? [Halve the speed of the liquid or decrease the opening between the two prisms.]

Now show slide P-9.

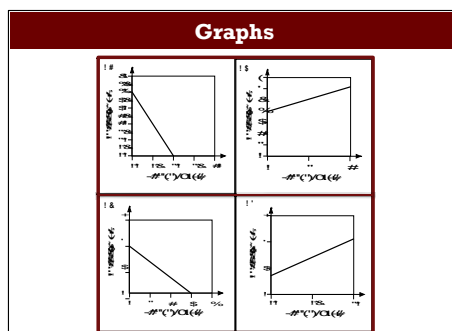

Explain to students that they will be working in groups on some of these cards.

The graphs represent the flow of a liquid either out of the top prism or into the bottom prism of the container. Use the information from the graphs to figure out two graphs that represent the top and bottom prisms of the same container. [G2 and G6.]

This should allow students to absorb the context of the task individually, so that when they start to work in groups they **all** have something to contribute, not just the faster thinkers.

Collaborative activity 1: Matching Graphs (20 minutes)

Organize the class into groups of two or three students. Give each group the cards *Graphs 1* and *2*. Explain how students are to work collaboratively.

The graphs I've given out represent the flow of a liquid either out of the top prism or into the bottom prism of the container.

Take it in turns to match two cards that represent the movement of liquid in one container.

Place them next to each other, not on top so that everyone can see.

When you match two cards, explain how you came to your decision.

Your partner should either explain that reasoning again in his or her own words, or challenge the reasons you gave.

You both need to be able to agree on and explain the match of every card.

Some graphs are missing information, such as a scale along an axis. You will need to add this scale.

Slide P-10, *Working Together*, summarizes how students should work together.

The purpose of this structured group work is to make students engage with each other's explanations, and take responsibility for each other's understanding.

If some students are finding this matching difficult then give them the cards *Flowing Liquid*. Students are to match one of these cards with two of the *Graph* cards.

While students work in small groups move around the class, noting different student approaches to the task and supporting student reasoning.

Note different student approaches to the task

Notice how students make a start on the task, where they get stuck, and how they respond if they do come to a halt. Do students assume that two matched *Graph* cards must have the same vertical intercept? Do students pay attention to the scale? Are students figuring out the slope and if so do they use ratios or fractions? Do students look at multiple attributes of each graph? You can use this information to focus a whole-class discussion towards the end of the lesson.

Support student reasoning

Try not to make suggestions that move students towards a particular placement. Instead, ask questions to help students to reason together.

If students get stuck you may want to ask:

Can you think of one specific question you want to ask?

This question requires students to think carefully about the task, and in so doing may help them to get started. Either answer the question yourself, or ask a member of the group to answer the question.

State one thing this graph tells you about the flow of the liquid. Now tell me another.

What is the start height of the liquid? What must the start height for its connecting prism be?

How many seconds is the liquid flowing? How many seconds must the liquid be flowing in the connecting prism?

How is the speed of flow of liquid represented in this graph? What is it?

To ensure students are explaining their reasoning to one another, you may want to ask:

Amy matched these two cards. Andrew, why does Amy think these two cards go together?

If you find the student is unable to answer that question, ask them to discuss the matching further. Explain to the group that you will return in a few minutes to ask a similar question.

Taking two lessons to complete all activities

If you decide to extend the lesson over two periods then 5 minutes before the end of the first lesson ask students to note down their existing card matches, and then paper clip all their cards together.

At the start of the second lesson spend some time reminding the class about the activities.

Sharing Work (10 minutes)

As students finish matching the cards, ask one student from each group to visit another group's desk.

If you are staying at your desk, be ready to explain the reasons for your group's graph matches.

If you are visiting another group, copy your matches onto a piece of paper.

Go to another group's desk and check to see which matches are different from your own. If there are differences, ask for an explanation. If you still don't agree, explain your own thinking.

When you return to your own desk, you need to consider as a group whether to make any changes to your own work.

You may want to use Slide P-11 of the projector resource, *Sharing Work*, to display these instructions.

Collaborative activity 2: Matching Equations and Prisms (15 minutes)

As groups complete the *Sharing Work* activity give them the *Equations* cards.

These cards represent algebraically the flow of liquid.

You are now to match each of these cards with the cards already on your desk.

If there is no equation card for your matches, make one up!

Again encourage students to spend some time thinking about how they intend to complete the task.

Support the students as in the first collaborative activity.

For this equation, before liquid starts to flow, what is the height of the liquid? How do you know?

Does this equation represent the top or bottom prism? How do you know?

How is the speed of flow represented in this equation?

As students finish the matching give to each group the *Flowing Liquid* cards.

These cards show the situation of the prisms before water has started to flow from the top prism to the bottom one. Students should add any missing information to the cards.

As students finish the activity give them a large sheet of paper for making a poster and a glue stick. They are to glue all the cards onto the paper and then attach the poster to the classroom wall for all to see.

Whole-class discussion (15 minutes)

Organize a discussion about what has been learned.

Depending on how the lesson went, you may want to first focus on the common mistakes students made, review what has been learnt and what they are still struggling with, and then extend and generalize the math.

Use what you have noticed about the way students have worked to select one or two groups to explain their approach.

How did you decide that this equation matched these graphs/ this picture?

How did you decide what to add to this card?

Does anyone have any questions about this method?

Did anyone use a different/ similar method?

If you have time to extend the math, write the equation below on the board:

$$h = 5t + 1$$

Ask the following questions in turn.

This equation describes the flow of liquid in one of the prisms of the container.

On your whiteboards write an equation that describes the flow of the liquid in the other prism of the same container. [$h = -5t + 5$.]

On your whiteboards write an equation that describes the flow of a liquid in this prism that takes half the time. [$h = -10t + 5$ or $h = -5t + 2.5$, when $h = 0$, $t = 0.5$]

On your whiteboards write an equation that describes the flow of liquid that takes one second longer. [$h = -2.5t + 5$, when $h = 0$ $t = 2$.]

Ask two or three students with different equations to explain them. Encourage the rest of the class to challenge their answers.

Make up your own equation. Describe to your neighbor how the flow of liquid represented by this equation compares to the flow described by the equation on the board.

Follow-up lesson: Reviewing the assessment task (20 minutes)

Return to the students their response to the original assessment task.

If students struggled with the original assessment they may benefit from revising this assessment. In order that students can see their own progress, ask them to complete the task using a different color pen. Otherwise give students a copy of the task *The Race (revisited)*.

To connect the lesson activity with the assessment you may first want to ask students:

What do the two measurements for the distance run, s and f , have in common with the measurement of the liquid in the two prisms of each container? [As one measurement increases the other decreases at the same rate. In the race, as the distance from the start increases, then the distance from the finishing line decreases at the same rate. The total distance, $s + f$ is constant (70) throughout the race. In the container, as the liquid in the bottom prism increases then the liquid in the top one decreases at the same rate. The total liquid in the top and bottom container is constant (6).]

Ask students to look again at their original, individual, solutions to the problems together with your comments. If you have not added questions to individual pieces of work then write your list of questions on the board. Students should select from this list only those questions they think are

appropriate to their own work. If you are short of time, you could set this task in the next lesson or for homework.

Read through your original solutions to The Race problems.

Make some notes on what you have learned during the lesson.

Use what you have learned to complete the new assessment task/revise your answers.

SOLUTIONS

Assessment Task: The Race

1. Emma. The slope of Emma's line is greater than Maggie's line.
2. $s = 2t + 30$.
3. Maggie starts the race 30 meters ahead of Emma. Emma runs 70 meters, Maggie runs 40 meters. Maggie runs at the constant speed of 2 meters per second. Emma runs at the constant speed of 5 meters per second. After 10 seconds Emma overtakes Maggie. Emma completes the race in 14 seconds, Maggie completes it in 20 seconds.
4. a.

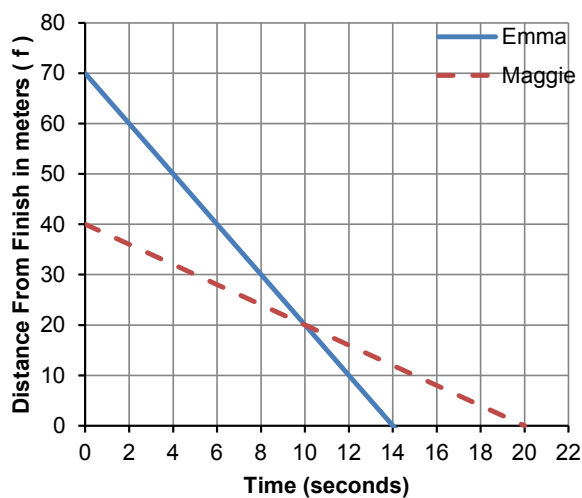

- b. $f = -2t + 40$

Collaborative activities

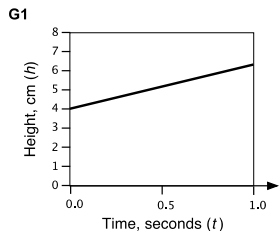

E12 $h = 2t + 4$

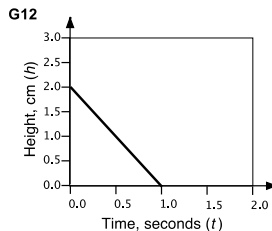

E5 $h = -2t + 2$

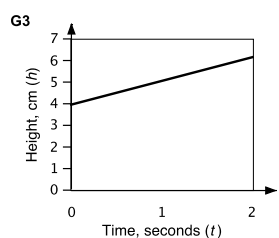
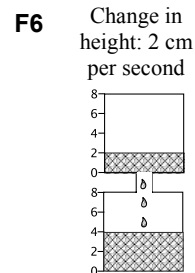

E3 $h = t + 4$

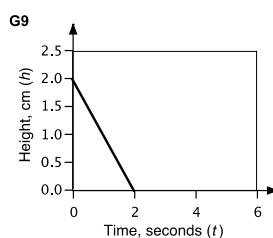

E9 $h = -t + 2$

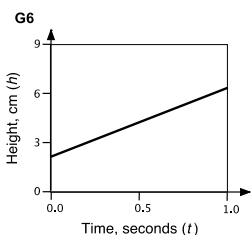
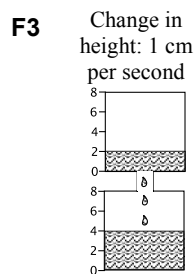

E4 $h = 4t + 2$

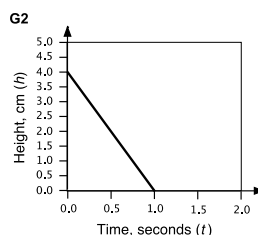

E6 $h = -4t + 4$

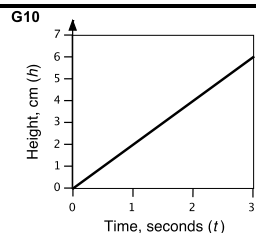
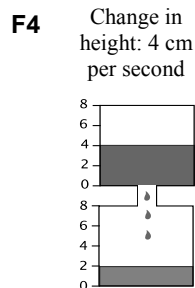

E2 $h = 2t$

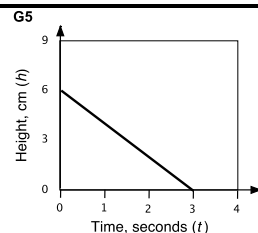

E8 $h = -2t + 6$

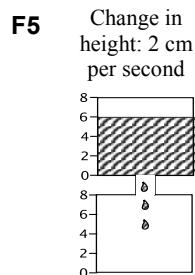

Collaborative activities (continued)

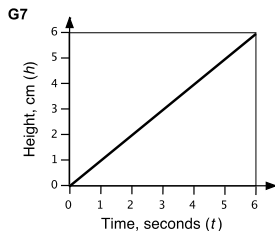

E7 $h = t$

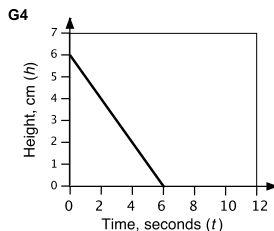

E1 $h = -t + 6$

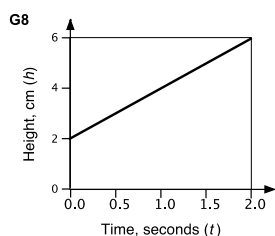
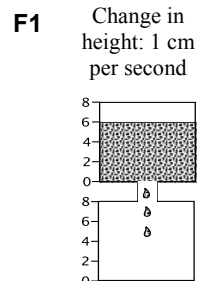

E10 $h = 2t + 2$

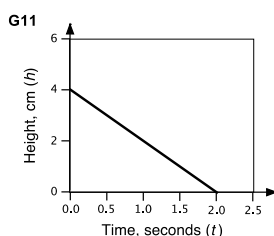

E11 $h = -2t + 4$

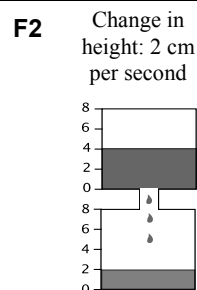

Assessment Task: The Race (revisited)

1. a & b.

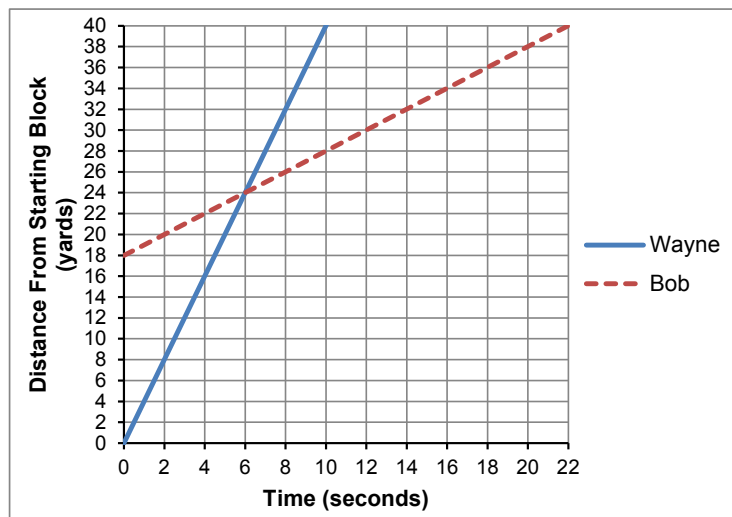

c. $s = t + 18$.

- Wayne is always running faster than Bob. The slope representing his race is always steeper than the slope representing Wayne's race.
- Equation of Wayne's line: $f = -4t + 40$. Equation of Bob's line: $f = -t + 22$.
- Wayne gets to the finishing line first. When $f = 0$ (at the finishing line) $t = 10$ for Wayne, but $t = 22$ for Bob. This means Wayne finishes the race 12 seconds before Bob.

The Race

Maggie and Emma race each other along a straight running track.

Maggie starts some distance ahead of Emma.

The graph describes the race.

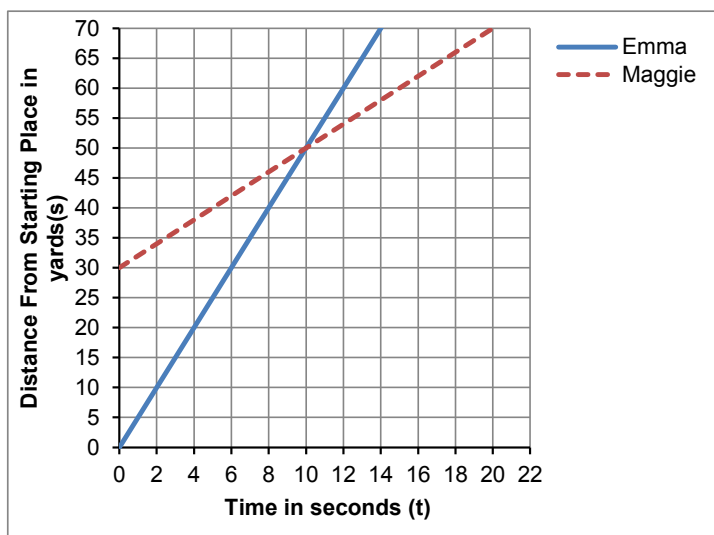

1. After 5 seconds, who is running the fastest? Explain your answer.

.....

.....

2. Emma's line can be represented by the equation:

$$s = 5t$$

s is the distance, in yards, from the Starting Place.

t is the time, in seconds, from the start of the race.

What is the equation that represents Maggie's line?

.....

3. Describe what happens in the race.

.....

.....

.....

.....

The diagram below shows the distance a runner is from the Starting Place and from the Finishing Line.

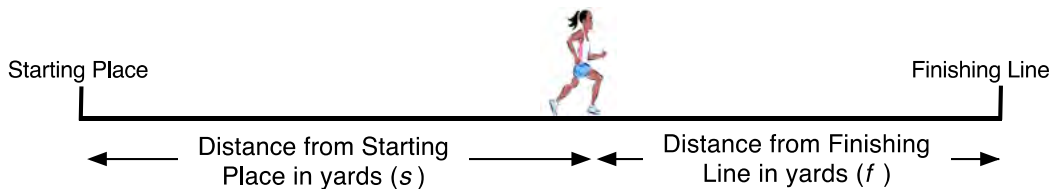

4. The following equation can also be used to describe Emma's race:

$$f = -5t + 70$$

f is the distance, in yards, from the **Finishing Line**.

t is the time, in seconds, from the beginning of the race.

a. Plot this line on the graph.

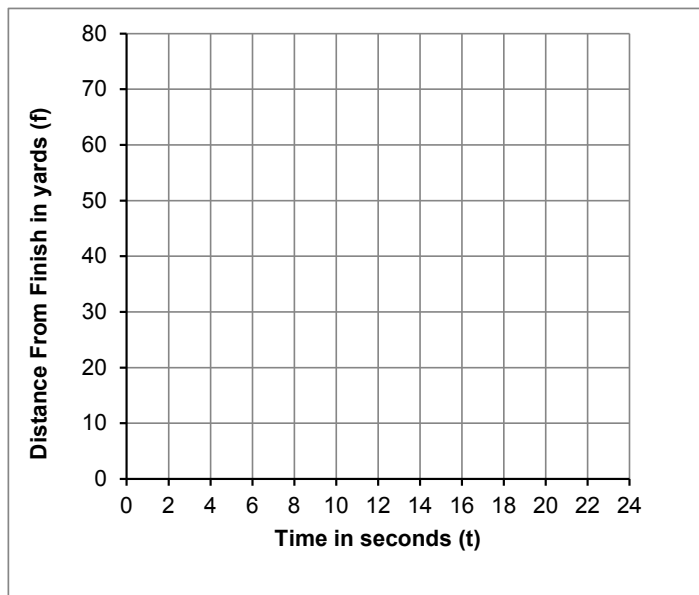

On this graph the distance is measured from the runner to the finish, not the start.

b. Add a line to the graph that represents Maggie's race.

c. What is the equation of this second line?

.....

Cards: Graphs 1

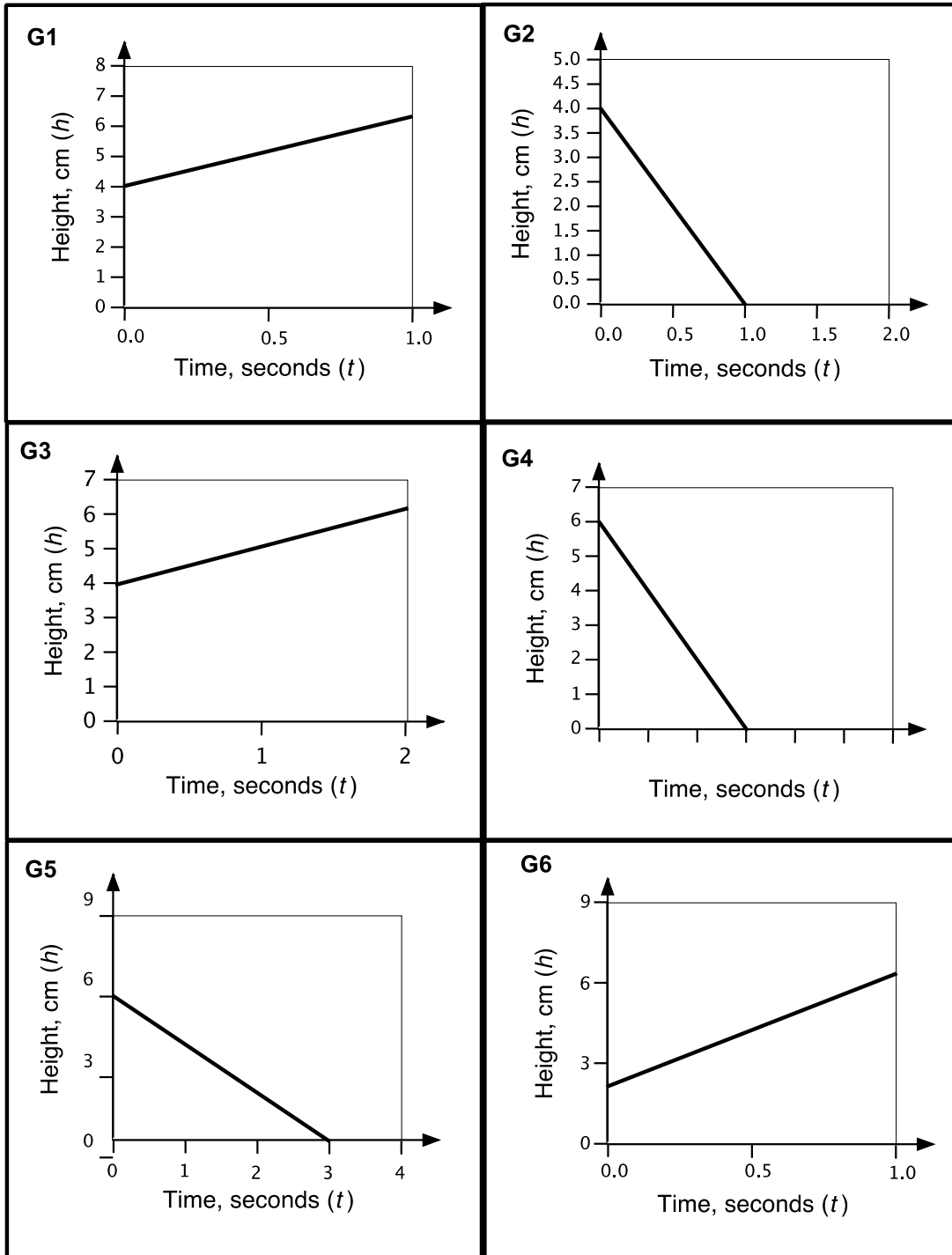

Cards: Graphs 2

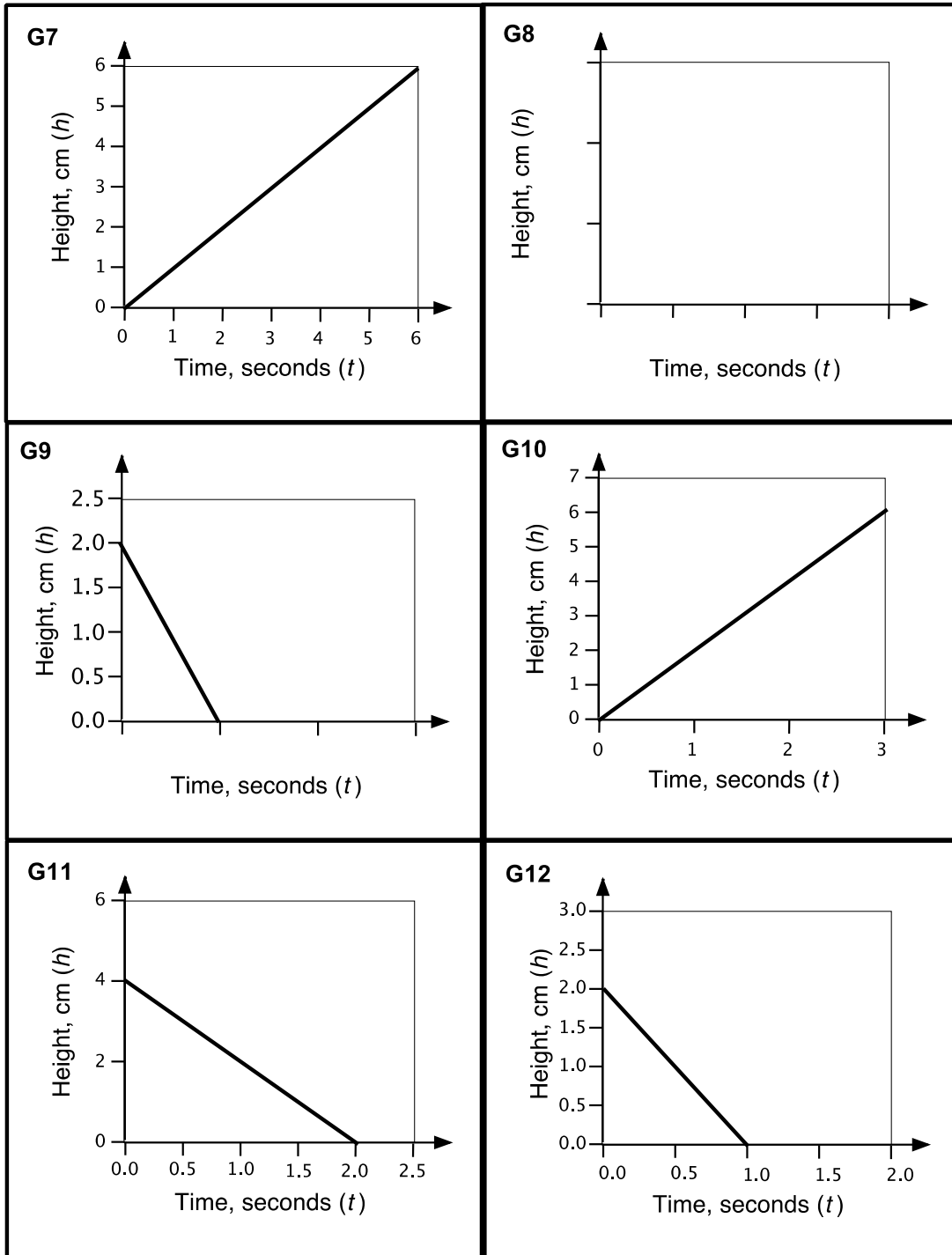

Cards: Equations

E1 $h = -t + 6$	E2 $h = -2t + 6$
E3 $h = t + 4$	E4 $h = 4t + 2$
E5 $h = -2t + 2$	E6 $h = -4t + 4$
E7 $h = t$	E8 $h = 2t$
E9 $h = -t + 2$	E10 $h = 2t + 2$
E11 $h = -2t + 4$	E12

Cards: Flowing Liquid

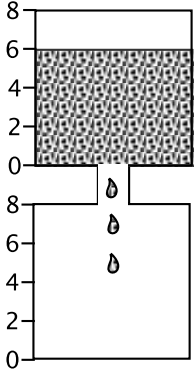
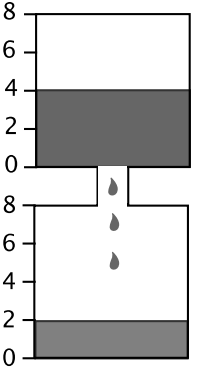
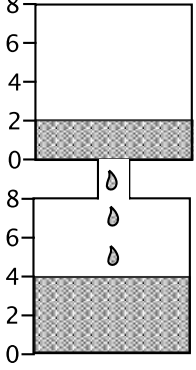
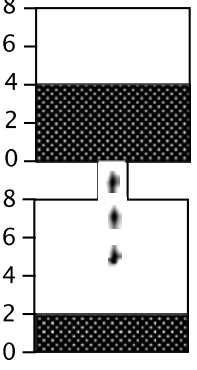
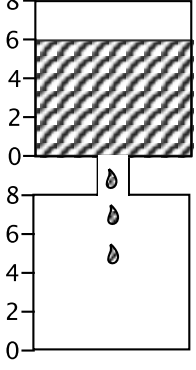
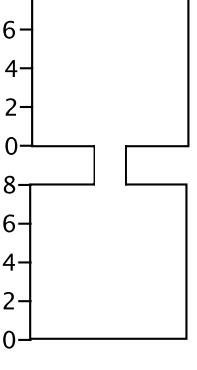
<p>F1 Change in height: 1 cm per second</p> 	<p>F2 Change in height: 2 cm per second</p> 
<p>F3 Change in height: 1 cm per second</p> 	<p>F4 Change in height: ___ cm per second</p> 
<p>F5 Change in height: ___ cm per second</p> 	<p>F6 Change in height: 2 cm per second</p> 

The Race (revisited)

Wayne and Bob race each other along a straight running track.

1. The following equation can be used to describe Wayne's race:

$$s = 4t$$

s is the distance, in yards, from the **Starting Line**.

t is the time, in seconds, from the beginning of the race.

- a. Plot this line on the graph.

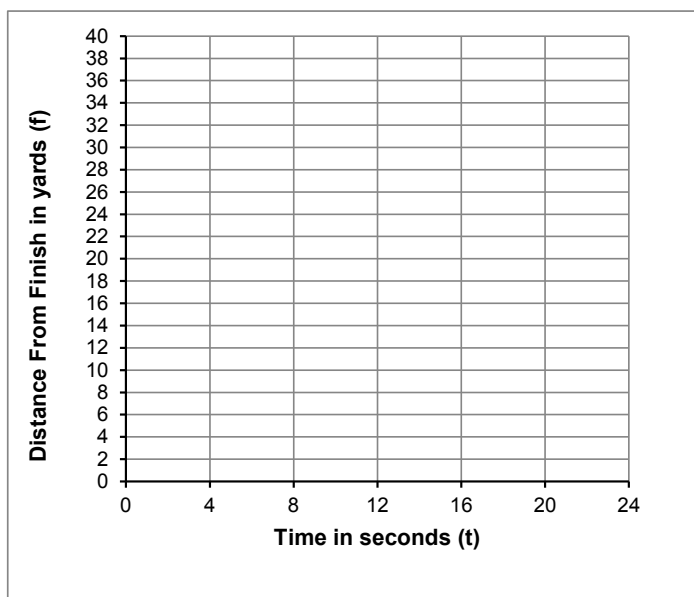

- b. Bob starts 18 yard ahead of Wayne. He runs at a speed of 1 yard per second. Plot a second line on the graph that represents Bob's race.
- c. What is the equation of this second line?
-

The diagram below shows the distance a runner is from the Starting Place and from the Finishing Line.

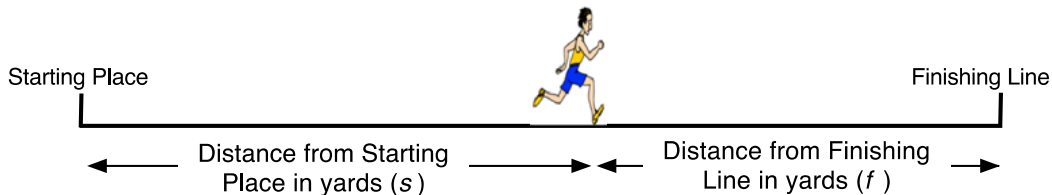

The graph describes the race.

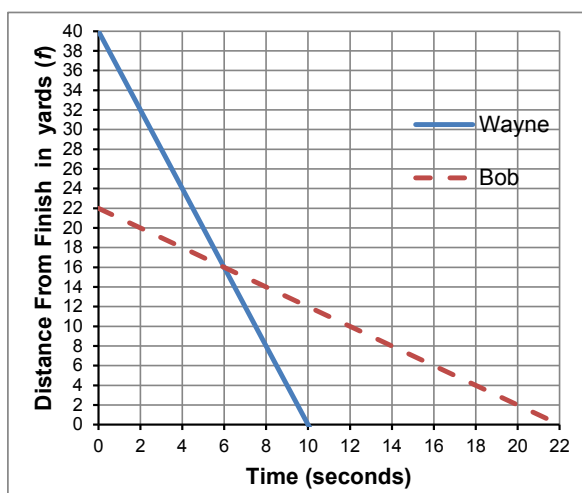

On this graph the distance is measured from the runner to the finish, not the start.

2. When is one runner running faster than the other? Explain how you know.

.....

.....

3. If f is the distance, in yards, from the Finishing Place.
 t is the time, in seconds, from the start of the race.

What are the equations of the two lines?

Equation of Wayne's line:

Equation of Bob's line:

4. Who gets to the finishing line first? Explain how you know.

.....

.....

.....

Flowing Liquid (1)

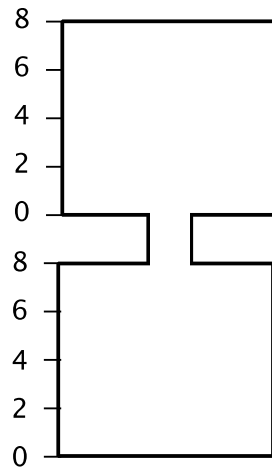

Flowing Liquid (2)

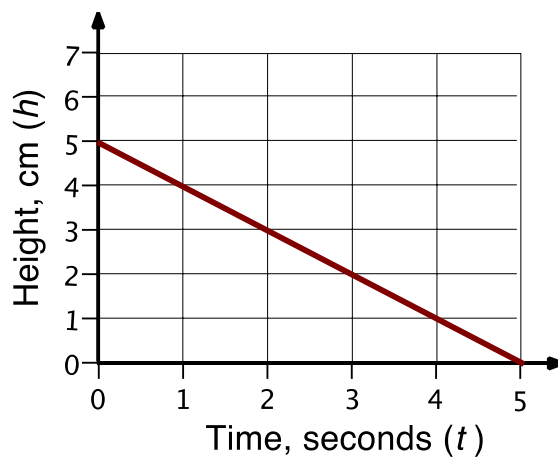
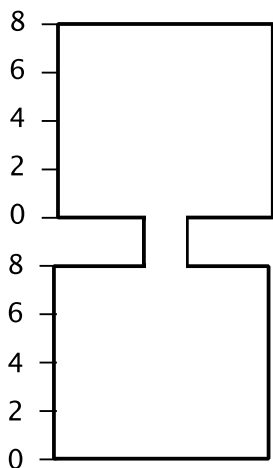

Liquid flowing out of the top prism 1

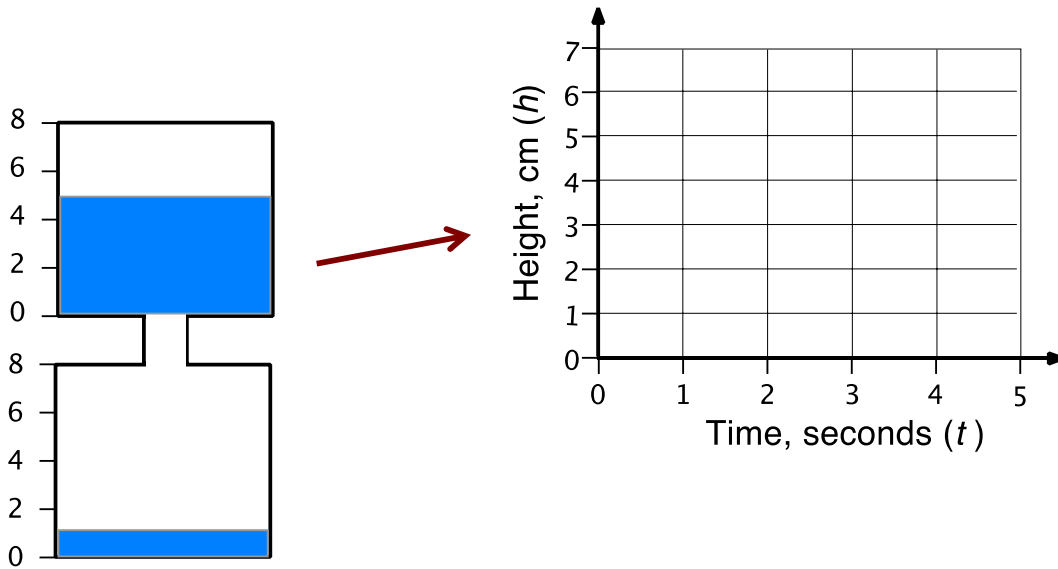

Liquid flowing out of the top prism 2

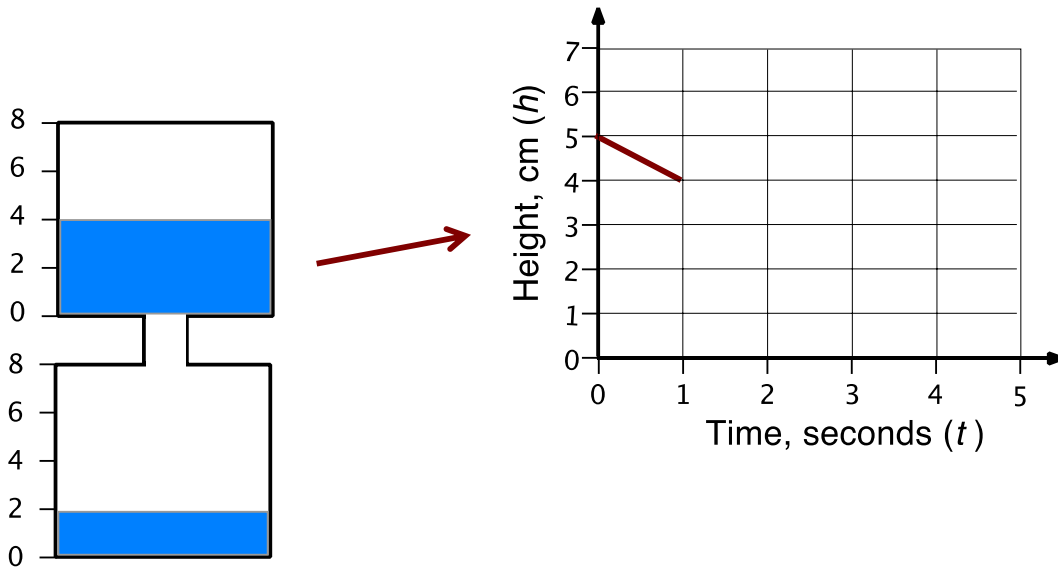

Liquid flowing out of the top prism 3

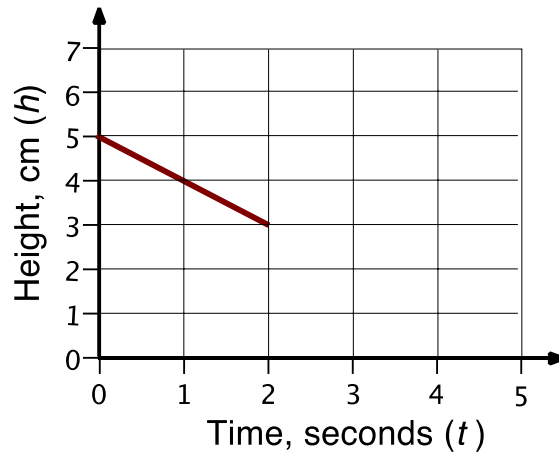
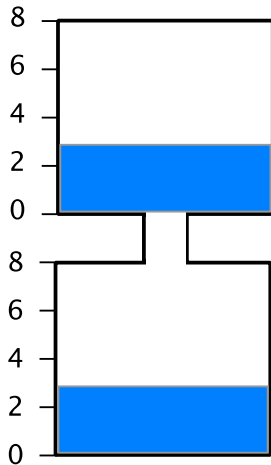

Liquid flowing out of the top prism 4

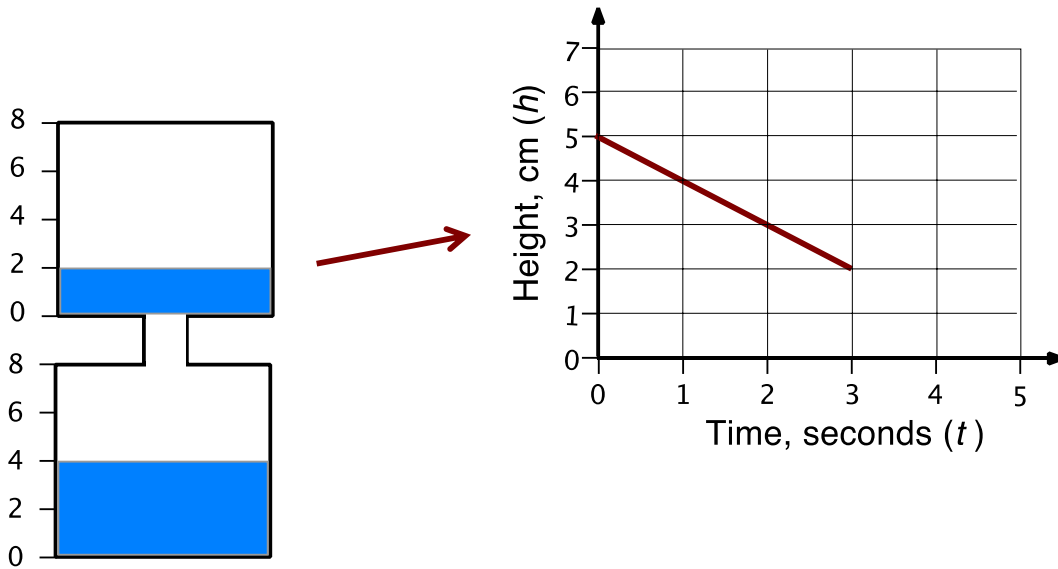

Liquid flowing out of the top prism 5

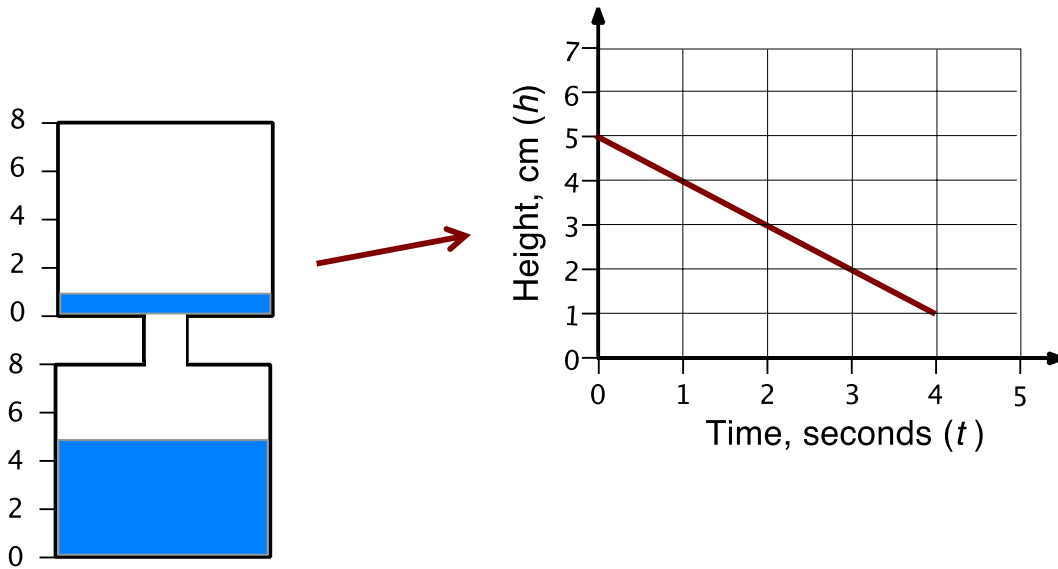

Liquid flowing out of the top prism 6

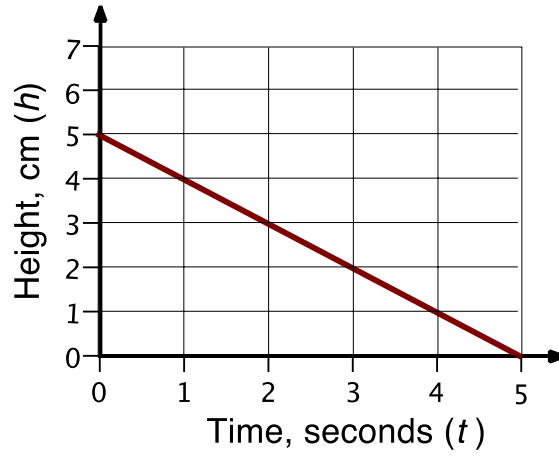
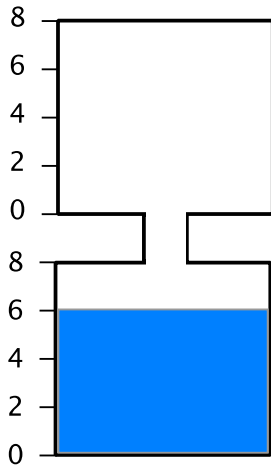

Graphs

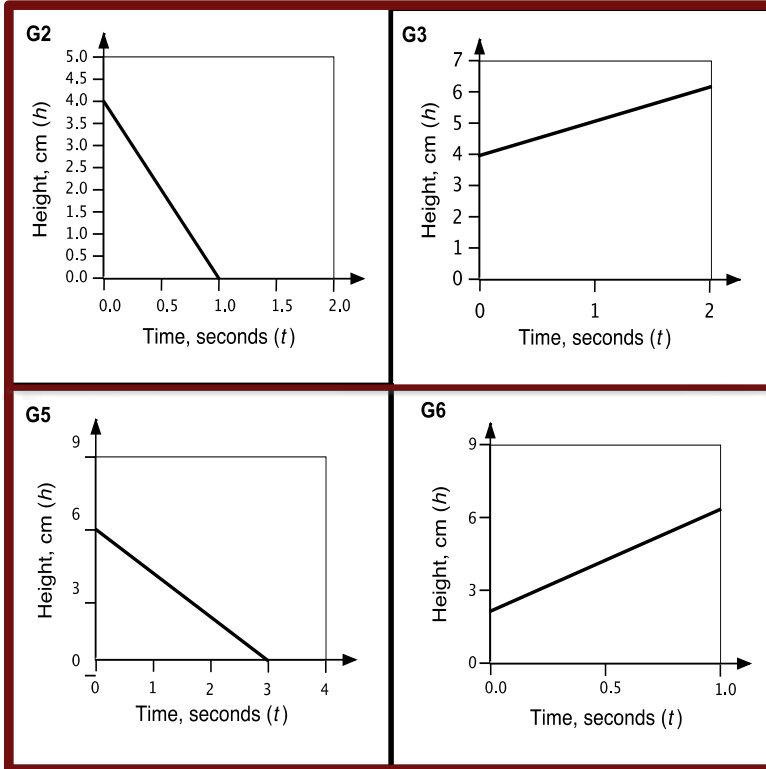

Projector Resources

Lines and Linear Equations

P-9

Working Together

1. The graphs represent the flow of a liquid either out of the top prism or into the bottom prism of the container.
2. Take it in turns to match two cards that represent the movement of water in one container.
3. Place the cards next to each other, not on top, so that everyone can see.
4. When you match two cards, explain how you came to your decision.
5. Your partner should either explain that reasoning again in his or her own words, or challenge the reasons you gave.
6. Some graphs are missing information, such as a scale along an axis. You will need to add this scale.

You both need to be able to agree on and explain the match of every card.

Sharing Work

1. If you are staying at your desk, be ready to explain the reasons for your group's graph matches.
2. If you are visiting another group, copy your matches onto a piece of paper.
3. Go to another group's desk and check to see which matches are different from your own. If there are differences, ask for an explanation. If you still don't agree, explain your own thinking.
4. When you return to your own desk, you need to consider as a group whether to make any changes to your own work.

Mathematics Assessment Project
CLASSROOM CHALLENGES

This lesson was designed and developed by the
Shell Center Team
at the
University of Nottingham
**Malcolm Swan, Clare Dawson, Sheila Evans,
Marie Joubert and Colin Foster**
with
Hugh Burkhardt, Rita Crust, Andy Noyes, and Daniel Pead

It was refined on the basis of reports from teams of observers led by
David Foster, Mary Bouck, and Diane Schaefer
based on their observation of trials in US classrooms
along with comments from teachers and other users.

This project was conceived and directed for
MARS: Mathematics Assessment Resource Service
by
Alan Schoenfeld, Hugh Burkhardt, Daniel Pead, and Malcolm Swan
and based at the University of California, Berkeley

We are grateful to the many teachers, in the UK and the US, who trialed earlier versions
of these materials in their classrooms, to their students, and to
Judith Mills, Mathew Crosier, Nick Orchard and Alvaro Villanueva who contributed to the design.

This development would not have been possible without the support of
Bill & Melinda Gates Foundation
We are particularly grateful to
Carina Wong, Melissa Chabran, and Jamie McKee

© 2013 MARS, Shell Center, University of Nottingham
This material may be reproduced and distributed, without modification, for non-commercial purposes,
under the Creative Commons License detailed at <http://creativecommons.org/licenses/by-nc-nd/3.0/>
All other rights reserved.
Please contact map.info@mathshell.org if this license does not meet your needs.

Linear Functions

Lesson 6 of 7

Applications of Linear Functions

Description:

In this lesson, students will be able to apply what they have learned about linear functions by simulating a bungee jump. Students will use balloons filled with water and rubber bands to collect data and will then use that data to write the equation of a line of best fit. This equation will be used to predict the number of rubber bands needed to provide a safe, yet thrill-seeking jump for the jumper (i.e., the balloon). Not only will students need to write an equation from two points, but will again be asked to explain the slope and y-intercept in the context of the problem. They will conclude by completing an activity report describing the activity in its entirety. This will allow the teacher to determine not only if the student understands the mathematics but also if the student can adequately explain the process of the activity.

Georgia Standards of Excellence Addressed:

- SMGSE9-12.S.ID.6: Represent data on two quantitative variables on a scatter plot, and describe how the variables are related.
- MGSE9-12.S.ID.6c: Using given or collected bivariate data, fit a linear function for a scatter plot that suggests a linear association.

Standard(s) for Mathematical Practice Emphasized:

- SMP 1: Make sense of problems and persevere in solving them.
- SMP 3: Construct viable arguments and critique the reasoning of others.
- SMP 4: Model with mathematics.

Sequence of
Instruction

Activities Checklist

Engage



As a hook to the lesson, show a short video clip of a bungee jumper to illustrate the importance of making accurate predictions. A sample video can be found at: <https://vimeo.com/157295748>.

This lesson is designed to give students the experience of finding a line of best fit and allows them to use and apply their knowledge of linear functions in preparation for the culminating task where less guidance will be provided.

Explore

Explain the activity to students as follows:

You will use rubber bands and a balloon (your “jumper”) to simulate a bungee jump. The data you collect will be used to write an equation that models an actual jump from some specified location. Your job will be to estimate the height of the building in which the jump will take place and to then determine the number of rubber bands needed to make a safe but “thrill-seeking” jump coming as close as possible to the ground without touching.

The balloons should have varying amounts of water in them so that each “jumper” is unique. The balloons should NOT be water balloons but regular balloons as water balloons are designed to burst upon impact.

For this lesson, students will use the “eyeball” method (choosing two points) to find a line of best fit. A graphing calculator should then be used to quickly plot the data and their line of best fit in order to make adjustments, if necessary. If students have not recently used a graphing calculator to plot data, a short mini-lesson may be necessary to remind them how to edit a list and use statistical plots. On the other hand, some students may perform a linear regression on the data. Although this is not the focus of the lesson, students should not be discouraged from using this tool.

After all groups have made a prediction and attached their rubber bands, the class will gather at the jump site for the “final jump.” Each group will have an opportunity to perform their jump while the other groups observe and measure the accuracy of the jump. The class should determine which group provided the most thrill-seeking jump by using mathematical relationships to draw conclusions. Throughout this activity, students should continue to make sense of the problem and monitor their progress.

Practice Individually



After the final jump, students will individually complete the *Water Balloon Bungee Activity Report*. This is an opportunity for students to demonstrate their own understanding of the activity and linear equations, in general. Most importantly, this activity report will assess each student’s use of Mathematical Practice 3, specifically, their ability to construct a viable argument and communicate them in written form using mathematical language. Students should be given ample time to complete this activity report, as this will also serve to informally assess their understanding of the concept. If this formative assessment reveals gaps in students’ understanding, a differentiated lesson may be necessary prior to the next lesson.

INCLUDED IN THE STUDENT MANUAL

Task #9: Water Balloon Bungee Activity Report

Follow this outline to produce a neat, organized, thorough, and accurate report, with at least one paragraph for each section. Any reader of your report should be able to understand the activity without having participated in it.

A. Overview

Tell what the investigation was about by explaining its purpose or objective.

B. Data collection

Describe the data you collected and how you collected it.

C. Model

Provide your equation for the line of best fit. Tell how you found this equation and how your group chose this equation to represent your data.

D. Calculations

Explain how you determined how many rubber bands to use in the final jump. Show any calculations used to find the result.

E. Results

Describe what happened on the final jump. How did your water balloon compare with the others?

F. Conclusion

What problems did you have in this activity? What worked well? If you could repeat the whole experiment, what would you do to improve your results?

Explanation



A whole-group discussion on the Water Balloon Bungee activity should focus on the process students employed to predict the number of rubber bands needed, the key features of the graph (slope and y-intercept), and the successes and failures of the jump. Possible questions to guide the discussion are as follows:

- *Why was group x so successful?*
- *How did each group choose a slope for their line of best fit?*
- *What factors were considered when deciding on the number of rubber bands needed?*
- *What factors could have caused an inaccurate prediction?*

Closing Activity



Allow students to exchange their activity report with a classmate to review and critique. Students should have opportunities to read the arguments of others and be able to clarify or improve those arguments if they do not make sense. Thus, each student should provide feedback to her/his partner with suggestions for improvement. Allow time for students to revise their activity report before the final submission.

Independent Practice:

INCLUDED IN THE STUDENT MANUAL

Independent Practice

Jackson is in charge of creating the work schedule for employees at Big Waves Water Park. If too many employees are scheduled, the water park loses money. On the other hand, if too few employees are scheduled on a busy day, customers are unhappy and the water park could lose business. Jackson knows there is a relationship between the daily temperature and the number of customers, which, in turn, determines the number of employees needed.

Use the data below to do the following:

- a. Graph the data.
- b. Find an equation for the line of best fit.
- c. Predict the number of employees needed when the temperature is 77°.

Linear Functions

Lesson 7 of 7

Culminating Task: When will the 25th Billionth iTunes App Be Downloaded?

Description:

Students will use their knowledge of linear functions to predict the time and date in which the 25 billionth iTunes app was downloaded. Using the same 16-minute video shown at the beginning of the unit, students will collect their own data and write an equation to best model that data. To conclude, students will examine data provided on the number of iTunes apps downloaded from 2008-2012. After graphing this data, students will then compare the graph to their graphs. This activity will give students the opportunity to realize how data collected over a short interval can look very different than data collected over an extended period of time. Students will have an opportunity to discuss factors that may contribute to the differences in the graphs and will be introduced to local linearity.

Georgia Standards of Excellence Addressed:

- MGSE9-12.S.ID.6: Represent data on two quantitative variables on a scatter plot, and describe how the variables are related.
- MGSE9-12.S.ID.6c: Using given or collected bivariate data, fit a linear function for a scatter plot that suggests a linear association.
- MGSE9-12.F.LE.1: Distinguish between situations that can be modeled with linear functions and with exponential functions.
- MGSE9-12.F.LE.3: Observe using graphs and tables that a quantity increasing exponentially eventually exceeds a quantity increasing linearly, quadratically, or (more generally) as a polynomial function.

Standard(s) for Mathematical Practice Emphasized:

- SMP 1: Make sense of problems and persevere in solving them.
- SMP 2: Reason abstractly and quantitatively.
- SMP 3: Construct viable arguments and critique the reasoning of others..

Sequence of Instruction

Activities Checklist

Engage

Engage students in a brief introductory discussion of the lesson. Begin by revisiting the video clip for the iTunes “count up” (<http://vimeo.com/37382647>). Discuss the following with students:

- *Can we apply anything we have learned to help make a more accurate prediction?*
- *Do we still think the data is linear?*
- *What new approaches might we have for predicting the date of the 25 billionth download?*

This conversation should be brief. The purpose is simply to get students thinking again about the iTunes data from perhaps a more mathematical perspective than when we first began the unit.

Explore



In this first segment, students will collect their own data using any method they chose to make a mathematical prediction for the download date (iTunes App Downloads). Each group of three or four will be provided the 16-minute video clip and a stopwatch. Students can choose the length of time in which to collect the data, the increments, and the amount of data to collect. The sample data in Lesson 1 only spans 90 seconds so students should have slightly different data now that they are allowed to use a 16-minute segment. If possible, provide each group with their own device in which to watch the video allowing them to start and stop the clip. If these resources are not available, play the video for the whole class.

INCLUDED IN THE STUDENT MANUAL

Task #10: iTunes App Downloads

In this activity, you will use your knowledge of algebra to make a prediction on when the 25 billionth iTunes app was downloaded.

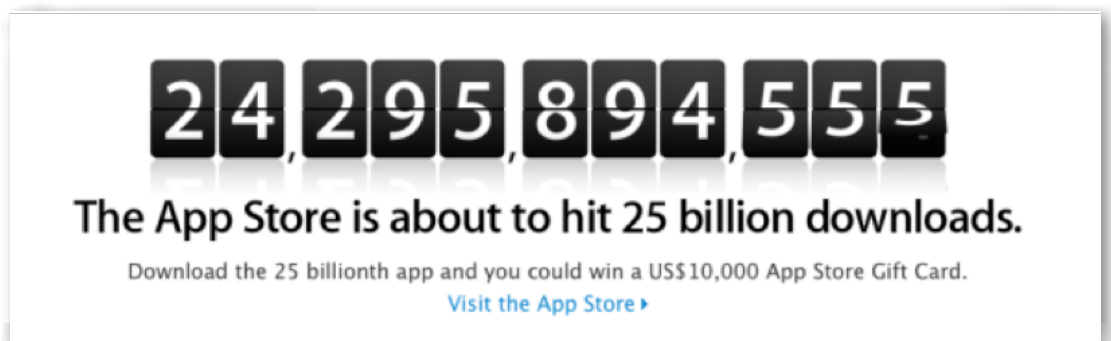

Use information provided in the 16-minute video clip (<http://vimeo.com/37382647>) to make a prediction on when the 25 billionth iTunes app was actually downloaded. You may decide exactly how your data will be collected but you must share your data in a table and a graph. After your data has been collected and recorded in a table and a graph, answer the following questions.

1. Find an equation that best models your data.
2. Graph your equation on the same graph with your data. Explain the key features of your graph and what they mean in the context of this problem.
3. Use your equation and other information provided in the video segment to predict the date of the 25 billionth download from the iTunes app store.

One possibility to consider for grouping is for students to work in the same groups as they did on day one of the unit when they made their initial predictions. There could also be a classroom competition on who can get the closest to the actual 25 billion app download date. (In the event that students find the actual download date and time online, they will still need to provide mathematics to support their prediction.)

Mathematical reasoning is in play as students decontextualize in order to create an equation and then contextualize in order to make sense of the problem.

Explanation



Each group of students should present their work to the class. Along with their equation and prediction, each group should briefly explain their data collection process. This is another opportunity to allow the students to lead the discussion by asking questions of their peers during the presentations, thus, exercising Mathematical Practice 3. Sample questions are as follows:

- *What does the y -intercept represent in this problem?*
- *What factors did your group consider when making your prediction?*
- *What method did you use to find a line of best fit?*

To conclude this segment, the teacher should provide students with the actual time and date of the 25 billionth download (10:50 p.m. PST on March 2, 2012).

In groups, students should be given time to reflect on the accuracy of their prediction. *How accurate was your prediction? What might have caused your date to be off?*

Explore



In this final segment of the lesson, students will look at data collected on the number of iTunes app purchases over an extended period of time. Students have already noticed that data collected from the 16-minute segment is almost perfectly linear. However, *if we looked at the number of iTunes apps downloaded over the time period since the app store was first launched in 2008, would the data look the same?* Pose this question to students and give them a couple of minutes in their groups to discuss.

Provide students with the data collected on iTunes app downloads from 2008-2012. Students should graph the data (preferably, using a graphing calculator at this point) and compare the graph to the graph of data collected over the 16-minute interval. *What do we notice? How are they alike? How are they different? What do the differences suggest? What might be contributing factors to these differences?* (The Cumulative App Download 2008-2012 bar graph can be provided if you would prefer students not take time to graph.)

Here, students are making use of problem solving as they make sense of this new look at the data over an extended period of time.

iTunes App Downloads 2008-2012

Cumulative number of apps downloaded from the Apple App Store from June 2008 to October 2012 (in billions).

Month	Downloads in Billions
July 2008	0.01
Sep 2008	0.10
Apr 2009	1.00
Jul 2009	1.50
Jan 2010	3.00
Apr 2010	4.00
Jun 2010	5.00
Sep 2010	6.50
Oct 2010	7.00
Jan 2011	10.00
Jun 2011	14.00
Jul 2011	15.00
Oct 2011	18.00
Mar 2012	25.00
Jun 2012	30.00
Sep 2012	35.00

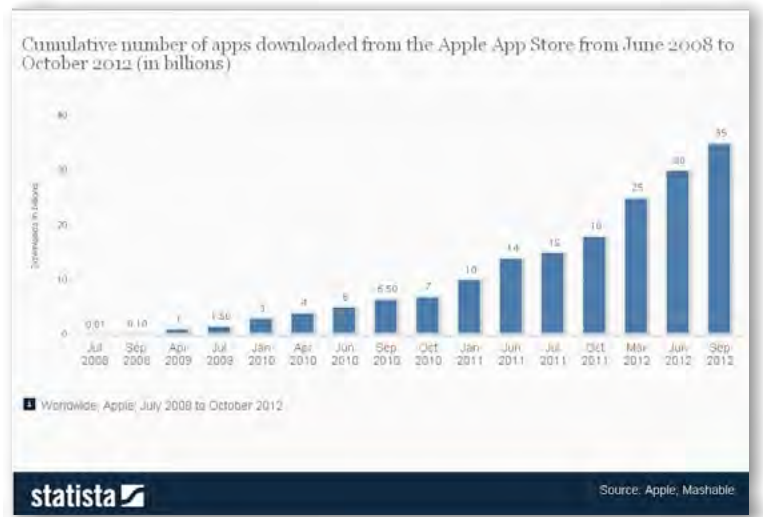

SREB Readiness Courses
Transitioning to college and careers

College Readiness Mathematics

Unit 4 . Linear Functions
Student Manual
Version 3

Name



Unit 4 . Linear Functions

Table of Contents

Lesson 1.....	3
Lesson 2.....	5
Lesson 3.....	12
Lesson 4.....	15
Lesson 6.....	21
Lesson 7.....	25

Frayer Map

Definitions		Characteristics	
Examples	Function		Non-Examples

Task #2: Peaches and Plums

The graphs below show the cost y of buying x pounds of fruit. One graph shows the cost of buying x pounds of peaches, and the other shows the cost of buying x pounds of plums.

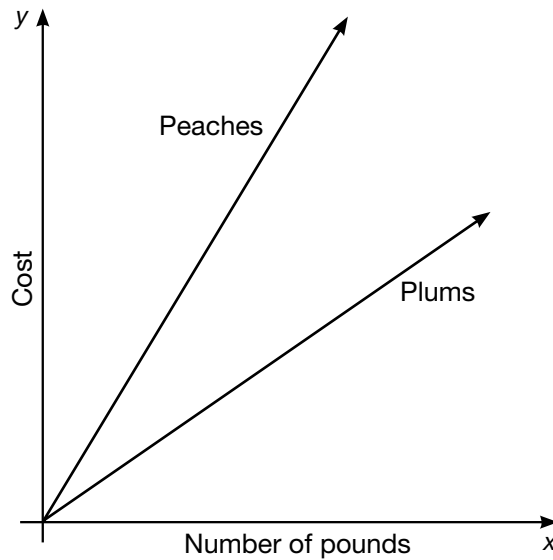

1. Which kind of fruit costs more per pound? Explain.

2. Bananas cost less per pound than peaches or plums. Draw a line alongside the other graphs that might represent the cost y of buying x pounds of bananas.

(Source: Illustrative Mathematics)

Task #3: Independent vs. Dependent

Independent vs. Dependent

For each situation, identify the independent and dependent variables.

- 1. The height of the grass in a yard over the summer.

Independent: _____

Dependent: _____

- 2. The number of buses needed to take different numbers of students on a field trip.

Independent: _____

Dependent: _____

- 3. The weight of your dog and the reading on the scale.

Independent: _____

Dependent: _____

- 4. The amount of time you spend in an airplane and the distance between your departure and your destination.

Independent: _____

Dependent: _____

- 5. The number of times you dip a wick into hot wax and the diameter of a handmade candle.

Independent: _____

Dependent: _____

- 6. The amount of money you owe the library and the number of days your book is overdue.

Independent: _____

Dependent: _____

7. The number of homework assignments you haven't turned in and your grade in math.

Independent: _____

Dependent: _____

8. The temperature of a carton of milk and the length of time it has been out of the refrigerator.

Independent: _____

Dependent: _____

9. The weight suspended from a rubber band and the length of the rubber band.

Independent: _____

Dependent: _____

10. The diameter of a pizza and its cost.

Independent: _____

Dependent: _____

11. The number of cars on the freeway and the level of exhaust fumes in the air.

Independent: _____

Dependent: _____

Task #4: Coffee by the Pound

Coffee by the Pound

Lena paid \$18.96 for 3 pounds of coffee.

a. What is the cost per pound for this coffee?

b. How many pounds of coffee could she buy for \$1.00?

c. Identify the independent and dependent variables for this problem.

d. Draw a graph in the coordinate plane of the relationship between the number of pounds of coffee and the price of coffee.

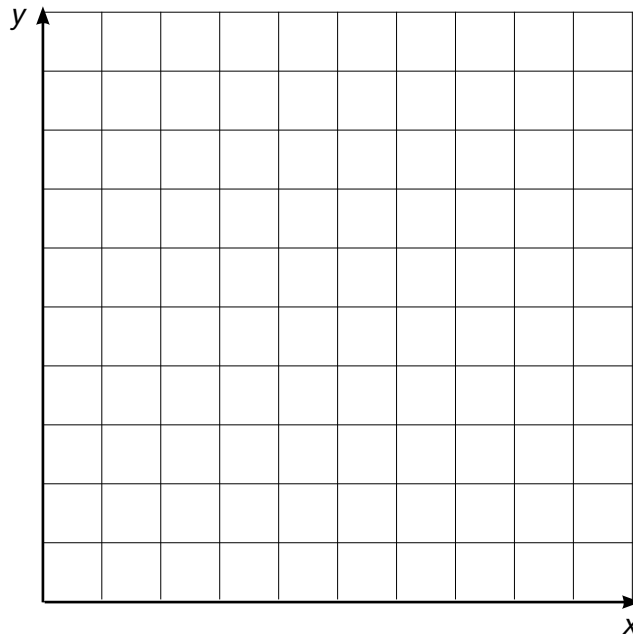

e. In this situation, what is the meaning of the slope of the line you drew in part (d)?

Task #5: Who Has the Best Job?

Kell works at an after-school program at an elementary school. The table below shows how much money he earned every day last week.

	Monday	Wednesday	Friday
Time Worked	1.5 hours	2.5 hours	4 hours
Money Earned	\$12.60	\$21.00	\$33.60

Mariko has a job mowing lawns that pays \$7 per hour.

- a. Who would make more money for working 10 hours? Explain or show your work.

b. Draw a graph that represents y , the amount of money Kell would make for working x hours, assuming he made the same hourly rate he was making last week.

c. Using the same coordinate axes, draw a graph that represents y , the amount of money Mariko would make for working x hours.

d. How can you see who makes more per hour just by looking at the graphs? Explain.

Task #6: Megan’s Disney Vacation

Megan and her family are travelling from their home in Nashville, TN to Orlando, FL on a Disney vacation. The trip is 685 miles and they will be travelling 65 miles per hour, on average.

Megan used the following equation to calculate the remaining distance throughout the trip:

$$D=685-65h$$

Discuss the following with your partner:

- The intercepts and slope and the meaning of each in the context of the problem.
- The independent and dependent variables.
- The domain and range.

Examine the graph of the equation below.

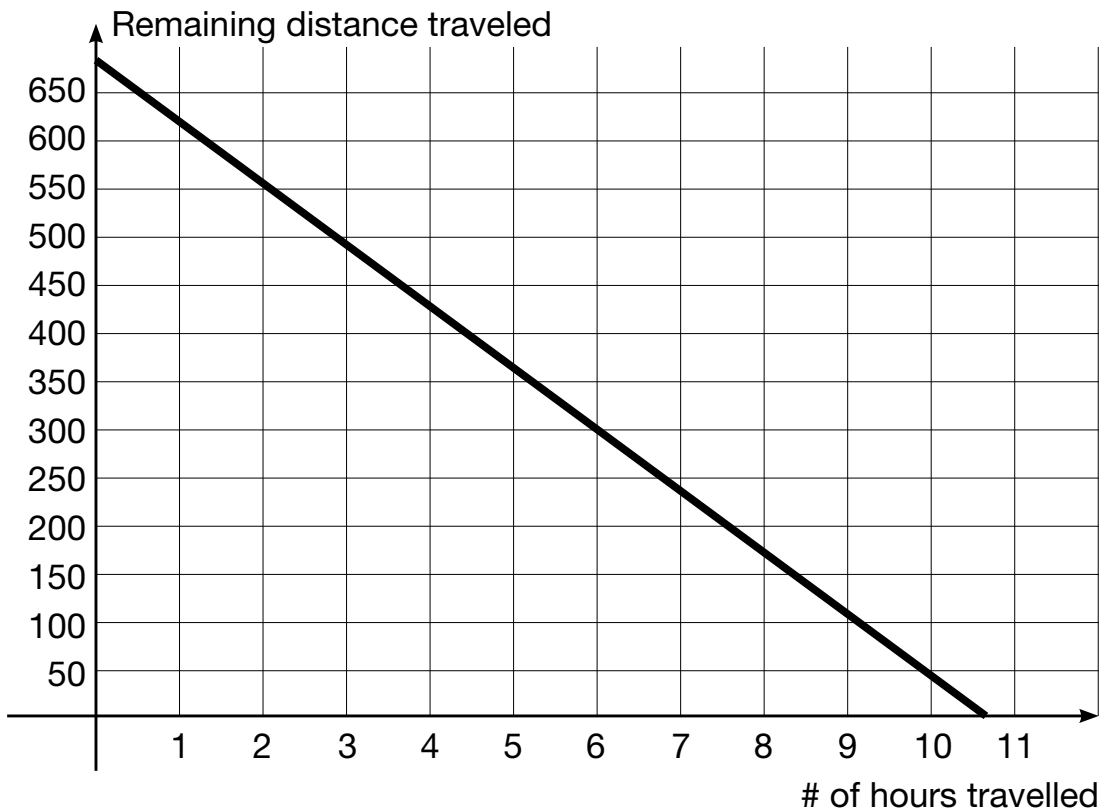

What steps might you take to graph this equation?

By studying the graph, where do you see the components of the graph mentioned above?

Exit Ticket: Graphing in Context

Carole owns a t-shirt company where she both designs and produces t-shirts for local individuals and businesses. Carole paid \$18,000 for the printing machine and it costs an additional \$5 for each t-shirt produced. An equation to model this situation is below:

$$C = 18,000 + 5t$$

1. What is the y-intercept and what does it mean in the context of this problem?

2. What is the slope and what does it mean in the context of this problem?

3. Graph the equation.

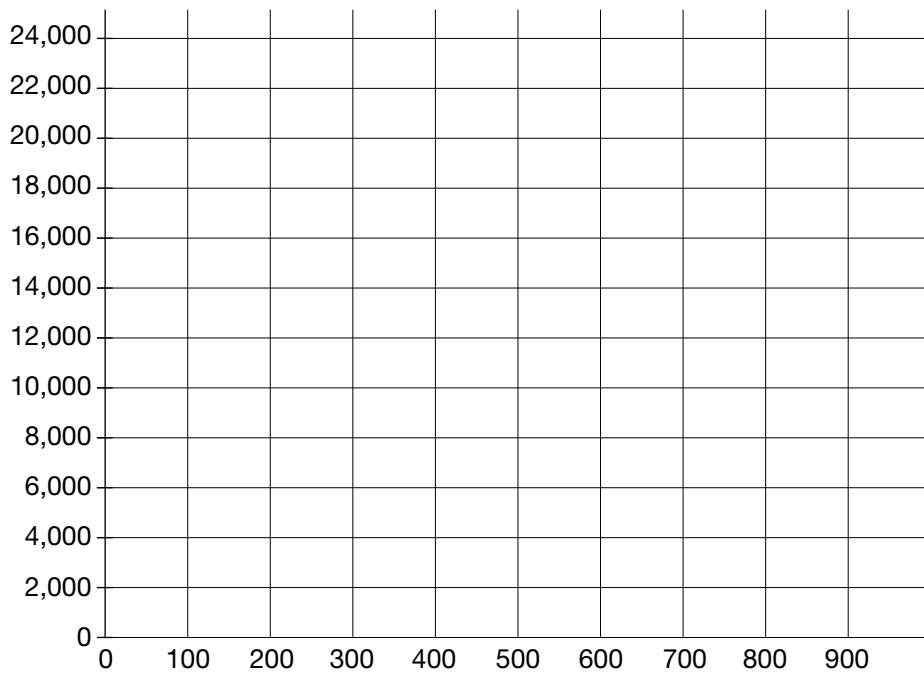

Task #7: Writing Linear Equations in Context

For each of the situations determine the slope, y-intercept, and x-intercept, along with each of their real-world meanings, when applicable. Additionally, write an equation to model the situation. Each equation should be written in the form most appropriate for the information provided.

1. To prepare for a recent road trip, Jill filled up her 19-gallon tank. She estimates that her SUV will use about three gallons per hour. Write an equation to model the amount of gasoline, G , remaining in her tank after t hours.

Slope: _____

Real-world meaning:

y-intercept: _____

Real-world meaning:

x-intercept: _____

Real-world meaning:

Equation: _____

2. Roberto deposits the same amount of money each month into a checking account. Use the table to write an equation to model his balance, B , after m months.

# of months	1	3	6
Balance	255	365	530

Slope: _____

Real-world meaning:

y-intercept: _____

Real-world meaning:

x-intercept: _____

Real-world meaning:

Equation: _____

3. Let f be the function that assigns to a temperature in degrees Celsius its equivalent in degrees

Fahrenheit. The freezing point of water in degrees Celsius is zero while in degrees Fahrenheit it is 32. The boiling point of water is 100 degrees Celsius and 212 degrees Fahrenheit. Given that the function f is linear, use this information to find an equation for f .

Slope: _____

Real-world meaning:

y-intercept: _____

Real-world meaning:

x-intercept: _____

Real-world meaning:

Equation: _____

4. At the beginning of October, Monique changed banks and decided to leave the remaining \$3900 in her old checking account to pay for rent. After six months, her balance was finally zero. If the balance, B , in Monique's account is a function of time, t , write an equation for the situation.

Slope: _____

Real-world meaning:

y-intercept: _____

Real-world meaning:

x-intercept: _____

Real-world meaning:

Equation: _____

5. On a recent scuba diving trip, Kate and Kara reached a depth of 130 feet. Six-and-a-half minutes later after ascending at a constant rate, they reached the surface. Write an equation to represent their distance, D , as a function of time, t .

Slope: _____

Real-world meaning:

y-intercept: _____

Real-world meaning:

x-intercept: _____

Real-world meaning:

Equation: _____

Task #8: More Modeling with Functions

1. A student has had a collection of baseball cards for several years. Suppose that B , the number of cards in the collection, can be described as a function of t , which is time in years since the collection was started. Explain what each of the following equations would tell us about the number of cards in the collection over time.

(a) $B = 200 + 100t$

(b) $B = 100 + 200t$

(c) $B = 2000 - 100t$

(d) $B = 100 - 200t$

2. Which of the following could be modeled by $y = 2x + 5$? Answer YES or NO for each one.

- (a) There are initially five rabbits on the farm. Each month thereafter the number of rabbits is two times the number in the month before. How many rabbits are there after x months?

Yes No

- (b) Joaquin earns \$2.00 for each magazine sale. Each time he sells a magazine he also gets a five-dollar tip. How much money will he earn after selling x magazines?

Yes No

- (c) Sandy charges \$2.00 an hour for babysitting. Parents are charged \$5.00 if they arrive home later than scheduled. Assuming the parents arrived late, how much money does she earn for x hours?

Yes No

- (d) I have a sequence of integers. The first term of the sequence is 7 and the difference between any consecutive terms is always equal to two.

Yes No

- (e) Sneak Preview is a members-only video rental store. There is a \$2.00 initiation fee and a \$5.00 per video rental fee. How much would John owe on his first visit if he becomes a member and rents x videos?

Yes No

- (f) Andy is saving money for a new CD player. He began saving with a \$5.00 gift and will continue to save \$2.00 each week. How much money will he have saved at the end of x weeks?

Yes No

3. A checking account is set up with an initial balance of \$4800, and \$400 is removed from the account each month for rent (no other transactions occur on the account).

- (a) Write an equation whose solution is the number of months, m , it takes for the account balance to reach \$2000.

- (b) Make a plot of the balance after m months for $m=1,3,5,7,9,11$ and indicate on the plot the solution to your equation in part (a).

Independent Practice

Write an equation to model each of the situations.

1. Cedric and Josh both ordered the same size pizzas at Marco’s Pizzeria; however, they ordered different toppings. Marco’s charges an additional fee for toppings, but all toppings cost the same. Cedric got pepperoni, banana peppers, and black olives on his pizza for a cost of \$15.74. Josh ordered mushrooms and eggplant on his pizza and paid \$14.49. Using this information, write an equation for the cost of a pizza, C , as a function of the number of toppings, t ordered.
-

2. College tuition at Bedrock University has increased \$500 per year for the past six years. Wilma is a freshmen this year and paid \$10,250 for her tuition. She is curious about her tuition in the coming years and needs this information as motivation to graduate in four years. Assuming the tuition rate increase remains constant, write an equation to represent the tuition at Bedrock University in x years.
-

3. Moche started a summer business of mowing lawns. However, before he could mow lawns, he needed to purchase supplies (a lawnmower among other needs). Moche spent \$395 gathering necessary materials. He makes on average \$60 per lawn, mowed. Write an equation to show Moche his earnings for l lawns mowed.
-

4. Margaret purchased a new bar of soap. Three days after she originally used the soap, she was curious how much soap per day she was using. She decided to weigh her soap and found that the bar was 103 grams. Four days later she re-measured the same bar of soap and recorded a weight of 80 grams. Assuming that Margaret uses the same amount of soap daily (and that she used the soap daily), write an equation that shows the amount of soap remaining after d days of use.
-

E. Results

Describe what happened on the final jump. How did your water balloon compare with the others?

F. Conclusion

What problems did you have in this activity?

What worked well?

If you could repeat the whole experiment, what would you do to improve your results?

Task #10: iTunes App Downloads**iTunes App Downloads**

In this activity, you will use your knowledge of algebra to make a prediction on when the 25 billionth iTunes app was downloaded.

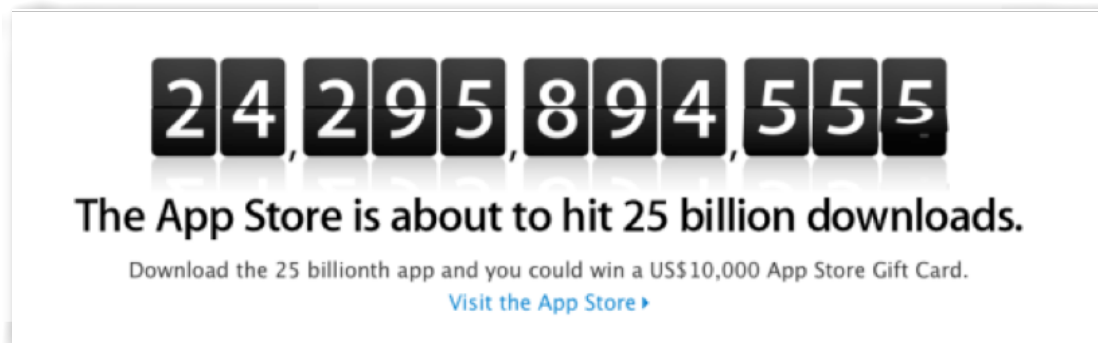

Use information provided in the 16-minute video clip (<http://vimeo.com/37382647>) to make a prediction on when the 25 billionth iTunes app was actually downloaded. You may decide exactly how your data will be collected but you must share your data in a table and a graph. After your data has been collected and recorded in a table and a graph, answer the following questions.

1. Find an equation that best models your data.
2. Graph your equation on the same graph with your data. Explain the key features of your graph and what they mean in the context of this problem.
3. Use your equation and other information provided in the video segment to predict the date of the 25 billionth download from the iTunes app store.

SREB

SREB Readiness Courses
Transitioning to college and careers

College Readiness Mathematics

Unit 5 . Linear Systems of Equations
Version 3

Southern
Regional
Education
Board

592 Tenth Street, NW
Atlanta, GA 30318
(404) 875-9211

www.sreb.org

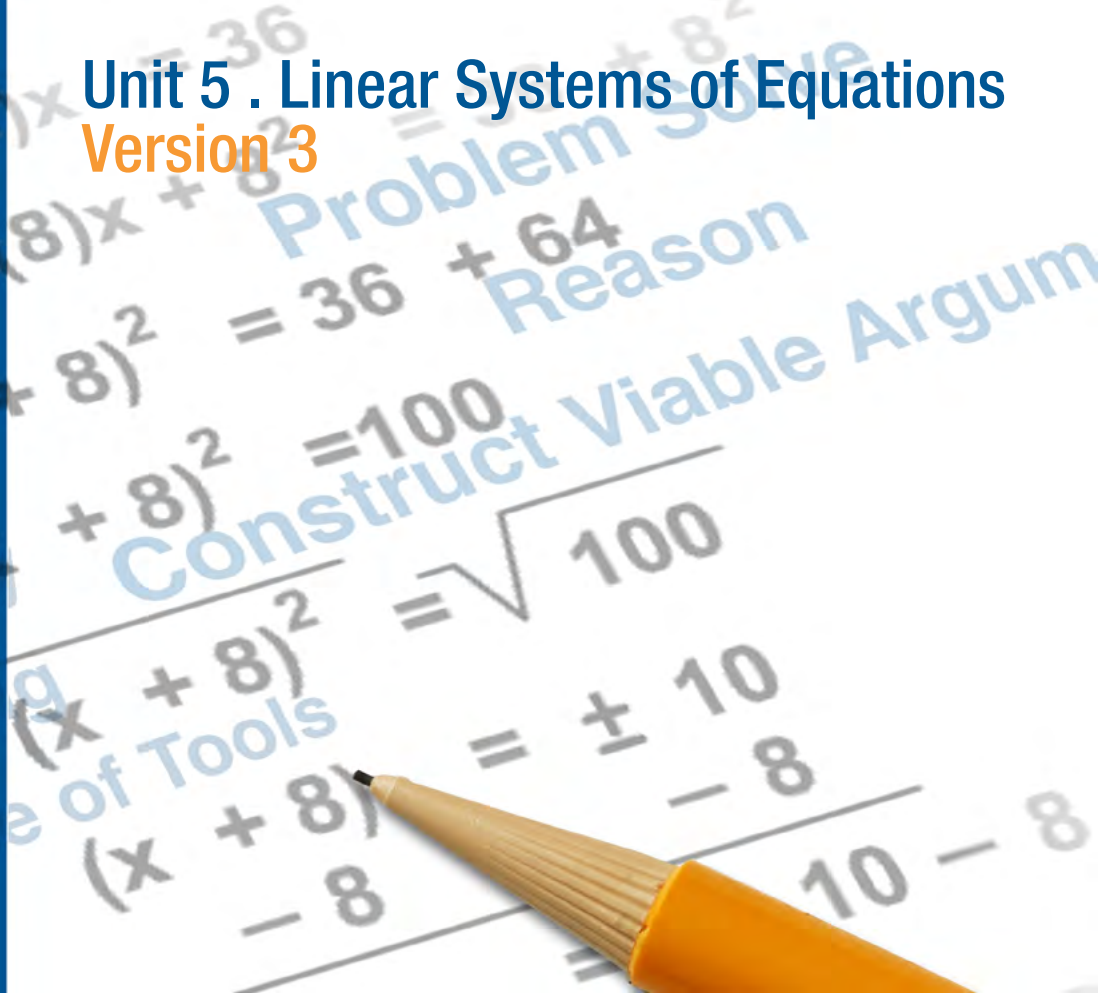

Unit 5 . Linear Systems of Equations

Overview

Purpose

The systems unit deals with solving systems of linear equations. This involves helping students to classify solutions (one, none, or infinitely many), as well as set up and solve problems using systems of equations. This unit also asks students to choose the best way to solve a system of equations and be able to explain their solutions.

Essential Questions:

Why might the need to solve a linear system of equations arise in life?

What tools can we use to solve a linear system of equations, and why might one be more useful than another?

Why is the solution (when there is one unique solution) to a system of linear equations represented by the intersection of the graphs of the two lines?

How many different types of solution sets are possible when solving a system of two linear equations?

How can we determine what type of solution set to expect?

What are common solution methods when working with a system of linear questions, and how can we determine which might be the most efficient method?

How can we represent constraints by equations and inequalities?

What is represented by the feasible region in a system of linear inequalities?

Georgia Standards of Excellence:

Creating Equations

Create equations that describe numbers or relationships.

- MGSE9-12.A.CED.2: Create linear, quadratic, and exponential equations in two or more variables to represent relationships between quantities; graph equations on coordinate axes with labels and scales. (The phrase “in two or more variables” refers to formulas like the compound interest formula, in which $A = P(1 + r/n)^{nt}$ has multiple variables.)
- MGSE9-12.A.CED.3: Represent constraints by equations or inequalities, and by systems of equations and/or inequalities, and interpret data points as possible (i.e. a solution) or not possible (i.e. a non-solution) under the established constraints.

Reasoning with Equations and Inequalities

Solve systems of equations.

- MGSE9-12.A.REI.5: Show and explain why the elimination method works to solve a system of two-variable equations.
- MGSE9-12.A.REI.6: Solve systems of linear equations exactly and approximately (e.g., with graphs), focusing on pairs of linear equations in two variables.

Represent and solve equations and inequalities graphically.

- MGSE9-12.A.REI.11: Using graphs, tables, or successive approximations, show that the solution to the equation $f(x) = g(x)$ is the x -value where the y -values of $f(x)$ and $g(x)$ are the same.
- MGSE9-12.A.REI.12: Graph the solution set to a linear inequality in two variables.

Interpreting Functions

Analyze functions using different representations.

- MGSE9-12.F.IF.9: Compare properties of two functions each represented in a different way (algebraically, graphically, numerically in tables, or by verbal descriptions). For example, given a graph of one function and an algebraic expression for another, say which has the larger maximum.

Prior Scaffolding Knowledge / Skills:

- Students should be procedurally fluent in solving linear equations using a variety of methods. (This should be developed in Unit 4.)
- Students should be able to analyze and solve pairs of simultaneous linear equations including real-world and mathematical problems.
- Students should be able to create equations that describe numbers or relationships.
- Students should be able to solve simple equations and inequalities and understand the solution as a point or a set of values. (This should be developed in Unit 2.)
- Students should be able to graph linear functions and discuss key features in graph, equation, and table. (This should be developed in Unit 4.)
- Students should be able to use the structure of a given equation to identify key concepts of a problem situation and interpret the quantity in terms of the given context.

Lesson Progression Overview:

Lesson Big Idea	Lesson Details	Georgia Standards of Excellence	Standards for Mathematical Practice
Lesson 1: Solving Systems of Equations	This lesson begins by providing students with a real-world problem involving cell phone plans and asks them to choose the best plan based upon certain criteria. In working through this problem, students will choose a method to solve a system of equations, specifically substitution or elimination. Finally, students will have the opportunity to solve systems of equations.	MGSE9-12.A.CED.2 MGSE9-12.A.REI.5 MGSE9-12.A.REI.6 MGSE9-12.A.REI.11	SMP 1 SMP 2 SMP 3 SMP 4 SMP 6
Lesson 2: Formative Assessment Lesson: Classifying Solutions (0, 1, or infinitely many)	This lesson begins with a formative assessment lesson that assesses student understanding of properties of systems of equations based upon the number of solutions. Then followed with additional application problems.	MGSE9-12.A.CED.2 MGSE9-12.A.CED.3 MGSE9-12.A.REI.6 MGSE9-12.F.IF.9	SMP 1 SMP 4 SMP 6
Lesson 3: Applications of Systems of Linear Equations	This lesson presents real-life applications of solving systems of equations and finding equations for lines in a given context.	MGSE9-12.A.CED.2 MGSE9-12.A.CED.3 MGSE9-12.A.REI.6	SMP 2 SMP 4 SMP 6
Lesson 4: Problem Solving Lesson: Optimization Problems: Boomerangs	The purpose of this lesson is to give students practice writing a constraint equation for a given context. This includes student understanding of the notion of a constraint equation as an equation governing the possible values of the variables in question.	MGSE9-12.A.CED.2 MGSE9-12.A.REI.12	SMP 1 SMP 2 SMP 3 SMP 4
Lesson 5: Formative Assessment Lesson: Defining Regions Using Inequalities	This lesson unit is intended to help you assess how well students are able to use linear inequalities to create a set of solutions. In particular, the lesson will help you identify and assist students who have difficulties in: <ul style="list-style-type: none"> • Representing a constraint by shading the correct side of the inequality line. • Understanding how combining inequalities affects a solution space. 	MGSE9-12.A.CED.3 MGSE9-12.A.REI.12	SMP 4 SMP 6 SMP 7
Lesson 6: Linear Programming	This lesson is the culmination of all lessons in this unit. It provides students with real-world situations in which they must solve problems to maximize revenue or minimize cost.	MGSE9-12.A.CED.3 MGSE9-12.A.REI.12	SMP 1 SMP 4

Entry Event: As a bridge between Unit 4 (Linear Functions) and Unit 5 (Linear Systems of Equations), the following activity is included for students and the teacher to make the link between examining one linear equation as opposed to a system of linear equations.

The activity can be completed either individually or in small groups using the following guidelines.

Individual:

Students work individually to complete the activity Wartime Battle. As students are working, make note of areas where students are struggling with concepts they seem to have mastered before. Then write math terms on the board regarding systems of equations. Students should define the terms they remember and write on chart paper the terms they don't remember. Collect the definitions and use the information to plan instruction.

Small Group:

Have groups of two to three students complete the activity Wartime Battle, with the following modifications:

Create large coordinate grids on the floor of the classroom using masking tape. Assign the activity, providing students with materials such as different color string, masking tape, measuring tools, etc., along with small colored pieces of paper used as the "mines." Avoid telling students how to use the materials, where to begin, etc. Step back and observe as students discuss and solve the problem. In particular, pay attention to how students approach ideas of scale, orientation, precision and graphing. Make note of appropriate vocabulary usage, whether or not students recognize the problem as a "system" and employ an algorithm to solve, or simply graph the lines using the slope, intercepts or table of values. Collect the information to plan instruction.

INCLUDED IN THE STUDENT MANUAL

Entry Event Activity

Wartime Battle

During war games, it is your job to navigate one of our battleships. Your course takes you over several enemy paths. As part of your duties, you must lay mines along the enemy's path. However, in order to plant the mines, you must know the points at which the paths cross and report those points to the Captain and to the Mine Crew. You know of 3 different enemy paths, which are denoted by the following equations:

Enemy Path 1: $x = 3y - 15$

Enemy Path 2: $4x - y = 7$

Enemy Path 3: $y = -1 - 2x$

Your battleship's course is denoted by this equation:

Battleship: $x + y = -5$

Using graph paper and colored pencils, determine where you need to plant the mines.

	(x, y) intersection
Enemy Path 1	
Enemy Path 2	
Enemy Path 3	

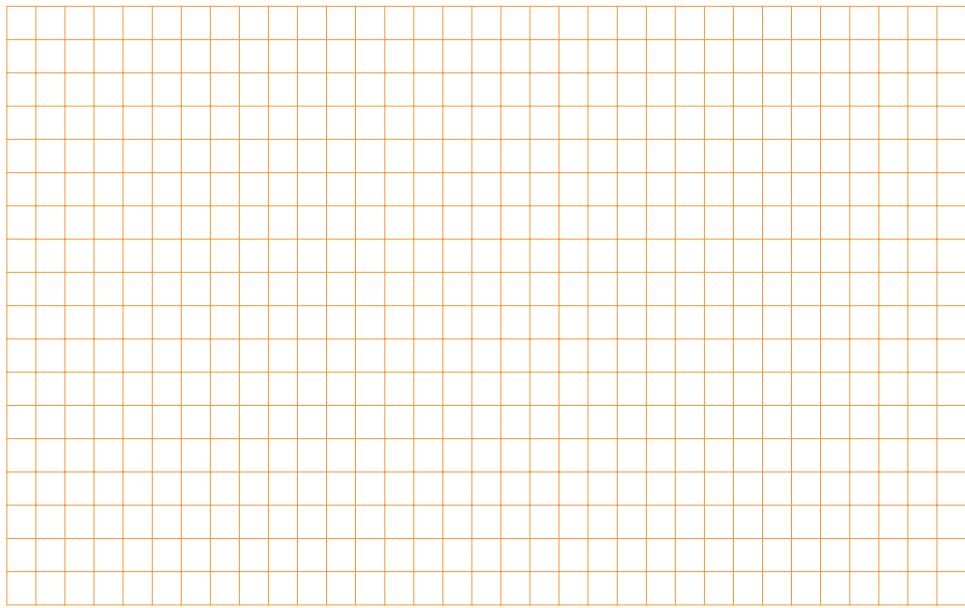

Wartime Battle Solution

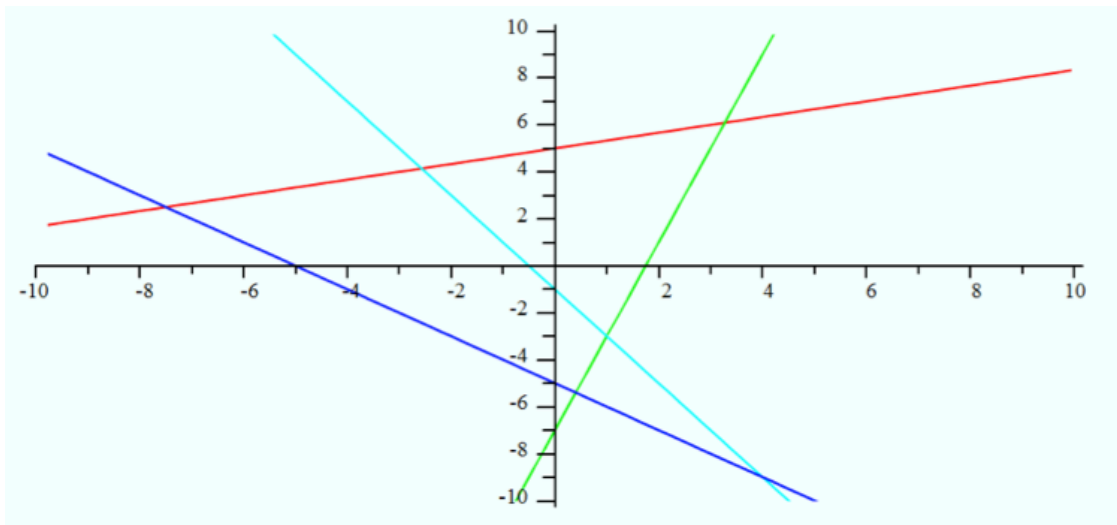

Enemy Path 1 is red.

Enemy Path 2 is green.

Enemy Path 3 is turquoise.

Your battleship course is dark blue.

Enemy Path 1 intersects the battleship course at $(-\frac{15}{2}, \frac{5}{2})$.

Enemy Path 2 intersects the battleship course at $(\frac{2}{5}, -\frac{27}{5})$.

Enemy Path 3 intersects the battleship course at $(4, -9)$.

Linear Systems of Equations

Lesson 1 of 6

Solving Systems of Equations

Description:

This lesson begins by providing students with a real-world problem involving cell phone plans and asks them to choose the best plan based upon certain criteria. In working through this problem, students will choose a method to solve a system of equations, specifically substitution or elimination. Finally, students will have the opportunity to solve systems of equations.

Georgia Standards of Excellence Addressed:

- AMGSE9-12.A.CED.2: Create linear, quadratic, and exponential equations in two or more variables to represent relationships between quantities; graph equations on coordinate axes with labels and scales. (The phrase “in two or more variables” refers to formulas like the compound interest formula, in which $A = P(1 + r/n)^{nt}$ has multiple variables.)
- MGSE9-12.A.REI.5: Show and explain why the elimination method works to solve a system of two-variable equations.
- MGSE9-12.A.REI.6: Solve systems of linear equations exactly and approximately (e.g., with graphs), focusing on pairs of linear equations in two variables.
- MGSE9-12.A.REI.11: Using graphs, tables, or successive approximations, show that the solution to the equation $f(x) = g(x)$ is the x -value where the y -values of $f(x)$ and $g(x)$ are the same.

Standard(s) for Mathematical Practice Emphasized:

- SMP 1: Make sense of problems and persevere in solving them.
- SMP 2: Reason abstractly and quantitatively.
- SMP 3: Construct viable arguments and critique the reasoning of others.
- SMP 4: Model with mathematics.
- SMP 6: Attend to precision.

Sequence of
Instruction

Activities Checklist

Engage



Begin class with the Comparing Phone Plans activity. (You can change the values to match actual phone plans phone companies offer, or to whatever you think is reasonable. Be careful if using actual plans since the plans can be quite complicated and make the model too hard to analyze—you might get piecewise defined functions which should be avoided for these purposes.)

INCLUDED IN THE STUDENT MANUAL

Task #1: Comparing Phone Plans

APlus telecommunications offers a plan of \$20 per month for an unlimited calling and data plan and 10 cents per text message sent. TalkMore, a competing company, offers a plan of \$55.00 per month for an identical unlimited calling and data plan and five cents per text message. How can you determine which plan will be cheaper for you?

Questions to guide the engagement:

Without “doing any math,” does anybody want to share their thoughts on what might be important to consider?

(If it does not naturally come up, try to steer the conversation towards the fact that if you text a lot, TalkMore will be cheaper whereas if you don’t send a lot of texts, APlus will be cheaper. Students are likely to pick up on this rather quickly.)

What constitutes “a lot” of texts in this scenario? You can poll the class to see how many text messages different students send per day in order to figure out approximately how many texts they send per month. Pick two students, one of which is less than the intersection point (in the example above $t=700$ texts, or about 23 texts per day would be the critical value). Ask the class the following, “Amber sends about 600 texts in a typical month while Ben sends about 800 texts in a typical month. Which plan is best for each of them? What are some ways we can help them decide?”

Call on volunteers to point out some useful tools that can be used in this analysis. Do not stop calling on volunteers until you hear use a table, use graphs and use formulas.

Now have students work in pairs or in groups of three on answering the question about which plan is best for each student using a table, equations and graphs.

Explore

Now, have students work in pairs or in groups of three on answering the question about which plan is best for each student using a table, graphs, and equations. Prompt students to think about the connections in using the different representations (table, equation or graph). At this point, most students should be proficient working with linear equations using these different representations. If they are having trouble getting started, suggest they may want to start with a table. If possible, have students work with small whiteboards or large pads of sticky paper so it will be easy to compare solutions.

	0	200	400	600	800	1000	1200	1400
APlus	20.00	40.00	60.00	80.00	100.00	120.00	140.00	160.00
TalkMore	55.00	65.00	75.00	85.00	95.00	105.00	115.00	125.00

While filling out the table, observe to see if students are discussing ideas such as, every time the number of texts increases by 200 (or some fixed amount), the fee from each company increases by a constant amount (\$20 and \$10 respectively), in other words discussing slope without possibly using that language. Also, see if students discuss how the table is consistent with the general observation that if you text a lot, TalkMore will be the cheaper plan.

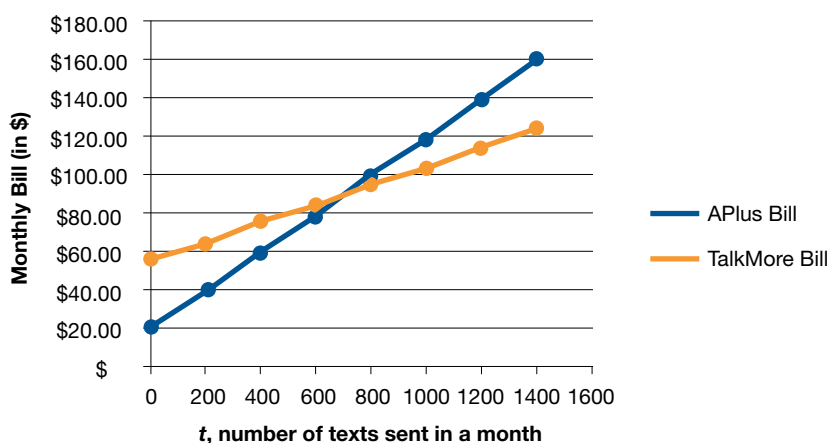

When drawing a graph, be sure students are precise and label axes, intercepts and scales along the axes. It is worth making sure students think about what an appropriate choice in scale should be on each axis (if they do the table earlier that should help).

If we let $f(t)$ denote the monthly bill from APlus and $g(t)$ denote the monthly bill from TalkMore, then we have $f(t)=20+0.10t$ and $g(t)=55+0.05t$. Setting the two bills equal to each other we have $20+0.10t=55+0.05t$ when $t=700$ texts. (You don't need to use functional notation, but getting students comfortable using different notation is important.)

Explanation



Ask groups to share their work and discuss how they can observe the same properties of the problem using each of the different representations, particularly the inference of the relationship between the intercepts and slopes. Be sure students can clearly explain how to interpret these features from a graph, equation and table and connect them back to the context. For example, from the equation $f(t)=20+0.10t$ we can see the slope is 0.10 texts per dollar (or 10 cents per text) and the y-intercept is at (0,20) which means if you don't send any text messages, the rest of the fees are \$20.00 per month.

Be sure students are clear WHY we set the equations equal to each other in order to find the number of texts for which the two bills will be the same. Why is this also the intersection of the two graphs? Why couldn't the number of texts for which the two bills are equal occur at another value for t other than 700? (If it were less, say $t=600$, we see the graph of TalkMore is above the graph of APlus, so APlus would be cheaper if $t=600$.) Make sure students understand from a practical point of view why we

set equations equal to each other and why visually this is the same as finding the point of intersection. Make sure they go back to their graphs and clearly label the intersection point if they haven't already done so.

In discussing solutions to the system of linear equations, students are likely to mention different methods such as elimination and substitution. Tell them they will be working on questions relating to those methods shortly. Before moving on, have the students discuss some of the following questions:

What would happen to the solution above if APlus increased the amount they charge per text? Decreased the amount they charge per text? Increased the monthly talk/data fee? Decreased the monthly talk/data fee? Tell students not to set up and solve equations in order to answer these questions. Gage to see if students understand how changing slopes and vertical intercepts will affect the intersection point. It may come up that sometimes two lines may not intersect at a single point. What if the lines are parallel? Tell them you will be discussing that shortly too.

Put the following problem on the board:

Let y be the monthly charge from a phone company when a customer sends t texts in a month.

Company 1's fees are given by the equation: $2t - 40y = -2200$.

Company 2's fees are given by the equation: $-15t + 100y = 2000$.

What is the corresponding number of texts at which the monthly bills of these two companies will be the same? Ask students to work on the solution in their groups.

This is a good opportunity to observe how comfortable students are using the methods of elimination and substitution.

Have students share solution methods, calling on groups that have used elimination, graphing and substitution. If no student makes the following observation, be sure to guide them appropriately towards the following: the equation for Company 1 is equivalent to the equation for TalkMore. Company 2 has the same monthly fee as APlus (\$20.00) but has a greater slope (fee per text). Thus when they find the solution, it is consistent with the previous observation that increasing the slope of APlus's graph would cause the point of intersection to occur when t is less than 700 texts. The algebra, the picture and the practical interpretation are all consistent.

If you observe students getting frustrated or having difficulty remembering these methods, you should slow down and spread the material for the rest of this day out over two days if needed. If students seem to recall these methods well, spend the rest of the period deepening their understanding and intuition about why and how we work systems of linear equations.

If students have questions about the methods for solving systems of equations, review the three methods with students.

Graphing

- Have students graph the following system of equations:

$$\begin{aligned}f(x) &= 2x - 7 \\g(x) &= -3x + 8\end{aligned}$$

- Be sure to discuss function notation.

- Ask students to discuss with a partner the solution and how they arrived at that solution.
- It is optional for the teacher if the students use a graphing calculator to do this.
- Discuss the fact that the x-coordinates of the points where the graphs of the equations $y = f(x)$ and $y = g(x)$ intersect are the solutions of the equation $f(x) = g(x)$.

Substitution

- Have students individually solve a system of linear equations (with a constant) such as:

$$\begin{aligned}x &= 2 \\ 2x + y &= 3\end{aligned}$$

- In pairs, have them share how they solved the system. Listen to discussions and find a student or pair of students who substituted a value to solve the system.
- Do the same with a system that has at least one equation with a variable with a coefficient of one (conducive to substitution).

$$\begin{aligned}2x + y &= 7 \\ x + 3y &= 6\end{aligned}$$

- Discuss substitution method. Have students solve the original equation from Lesson 1 using substitution. How do the answers compare?

Elimination

- Begin with a system of linear equations.

$$\begin{aligned}3x - 2y &= 5 \\ 4x + 2y &= 9\end{aligned}$$

- Have students solve using substitution. Discuss that substitution would be messy. Other solution methods?
- If we had a single equation, we could solve by adding the same thing to both sides.

$$\begin{aligned}4x - 3 &= 5 \\ +3 &= +3\end{aligned}$$

- We can do the same in the system by adding $4x + 2y$ to the left-hand side of the first equation and nine to the right-hand side of the first equation. Then we will eliminate a variable.
- Discuss the elimination method. Have students solve the original equation from Lesson 1 using elimination. How do the answers compare to the original and to the substitution method?

Which was easier? Why? Have students discuss in groups and share or write in a math journal.

Practice Together in Small Groups/Individually



Based on your observations of students' level of comfort and proficiency in working with systems of linear equations, decide which of the following sets of exercises is most appropriate to do in class. Other exercises may be assigned for homework, used for the closing activity or skipped altogether if no further practice is required.

Have students work in groups of three or four to complete the following activities. Then discuss the outcomes as a class.

INCLUDED IN THE STUDENT MANUAL

Task #2: Systems Activity

Work in teams of three (person A, person B, and person C). Each student is to complete his or her worksheet using the method as prescribed on the sheet, showing all work for each problem.

When you are finished, compare solutions for each corresponding system. Write the agreed upon solution in the appropriate column. Then discuss how you arrived at your solution. Was the method you used easier or more difficult than the others? Decide which method or methods the group found to be the ‘best’ or ‘preferred’ for each system (graphing, substitution or elimination). Give a reason for your answer. Simply saying, “it was the easiest method,” is not sufficient. Explain WHY you found the method to be the best—what made it easier?

SYSTEM	Solution	Preferred Method(s)	Reason
System 1 $\begin{cases} x + y = 4 \\ 2x - y = 5 \end{cases}$			
System 2 $\begin{cases} y = 4x + 6 \\ 2x - 3y = 7 \end{cases}$			
System 3 $\begin{cases} 3x + 2y = 8 \\ 5x - 3y = 7 \end{cases}$			

Person A

Graphing Method

$$x + y = 4$$

$$2x - y = 5$$

Substitution Method

$$y = 4x + 6$$

$$2x - 3y = 7$$

Elimination Method

$$3x + 2y = 8$$

$$5x - 3y = 7$$

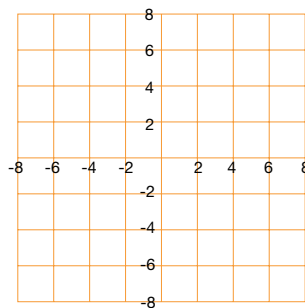

Person B

Graphing Method

$$3x + 2y = 8$$

$$5x - 3y = 7$$

Substitution Method

$$x + y = 4$$

$$2x - y = 5$$

Elimination Method

$$y = 4x + 6$$

$$2x - 3y = 7$$

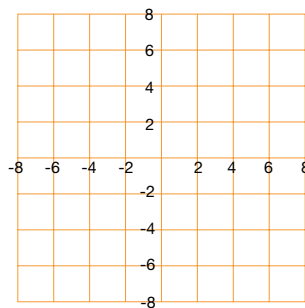

Person C

Graphing Method

$$y = 4x + 6$$

$$2x - 3y = 7$$

Substitution Method

$$3x + 2y = 8$$

$$5x - 3y = 7$$

Elimination Method

$$x + y = 4$$

$$2x - y = 5$$

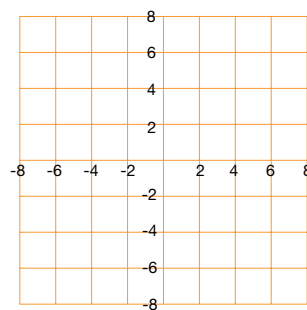

Solutions:

Person A

Graphing Method

$$x + y = 4$$

$$2x - y = 5$$

The solution is (3, 1).

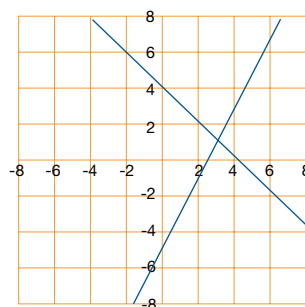

Substitution Method

$$y = 4x + 6$$

$$2x - 3y = 7$$

Substitute the first equation into the second.

$$2x - 3(4x + 6) = 7$$

$$2x - 12x - 18 = 7$$

$$-10x - 18 = 7$$

$$-10x = 25$$

$$x = -\frac{5}{2}$$

Substitute x-value into first equation.

$$y = 4\left(-\frac{5}{2}\right) + 6 = -10 + 6 = -4$$

The solution is $\left(-\frac{5}{2}, -4\right)$.

Elimination Method

$$3x + 2y = 8$$

$$5x - 3y = 7$$

Multiply the first equation by 3 and second by 2. Add.

$$9x + 6y = 24$$

$$10x - 6y = 14$$

$$19x = 38$$

$$x = 2$$

Substitute x into the first equation.

$$3(2) + 2y = 8$$

$$2y = 2$$

$$y = 1$$

The solution is (2, 1).

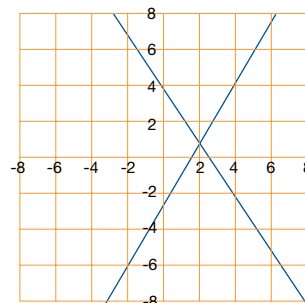

Person B

Graphing Method

$$3x + 2y = 8$$

$$5x - 3y = 7$$

The solution is (2, 1).

Substitution Method

$$x + y = 4$$

$$2x - y = 5$$

Solve the first equation for x.

$$x = 4 - y$$

Substitute into the second equation.

$$2(4 - y) - y = 5$$

$$8 - 2y - y = 5$$

$$-3y = -3$$

$$y = 1$$

Substitute the y-value into the first equation.

$$x = 4 - 1$$

$$x = 3$$

The solution is (3, 1).

Person C

Graphing Method

$$y = 4x + 6$$

$$2x - 3y = 7$$

The solution is $(-\frac{5}{2}, -4)$.

Elimination Method

$$y = 4x + 6$$

$$2x - 3y = 7$$

Rewrite the first equation and multiply the second equation by 2. Add.

$$-4x + y = 6$$

$$4x - 6y = 14$$

$$-5y = 20$$

$$y = -4$$

Substitute y-value into the first equation.

$$-4 = 4x + 6$$

$$-10 = 4x$$

$$-\frac{5}{2} = x$$

The solution is $(-\frac{5}{2}, -4)$

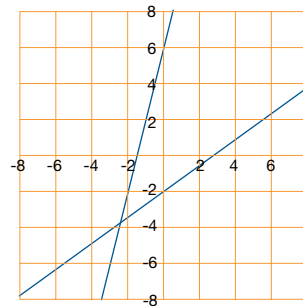

Substitution Method

$$3x + 2y = 8$$

$$5x - 3y = 7$$

Solve the first equation for y.

$$2y = 8 - 3x$$

$$y = 4 - \frac{3}{2}x$$

Substitute into the second equation.

$$5x - 3(4 - \frac{3}{2}x) = 7$$

$$5x - 12 + \frac{9}{2}x = 7$$

$$\frac{19}{2}x = 19$$

$$x = 2$$

$$y = 4 - \frac{3}{2}(2) = 4 - 3 = 1$$

The solution is (2, 1).

Elimination Method

$$x + y = 4$$

$$2x - y = 5$$

Add the two equations.

$$x + y = 4$$

$$2x - y = 5$$

$$3x = 9$$

$$x = 3$$

Substitute the x-value into one equation.

$$3 + y = 4$$

$$y = 1$$

The solution is (3, 1).

INCLUDED IN THE STUDENT MANUAL

Task #3: Classifying Solutions

Solve each system of equations in the following ways:

- a) Graphing.
- b) Algebraically— substitution or elimination (addition).

1) $2x + 3y = 9$

$-4x - 6y = -18$

- a. Solve graphically.
- b. Solve algebraically.
- c. What do you notice about the lines?
- d. What is the solution? Where do the lines intersect? How many solutions exist?
- e. Is the system consistent or inconsistent? Are the equations dependent or independent?

2) $x - 2y = 8$

$3x - 6y = 6$

- a. Solve graphically.
- b. Solve algebraically.
- c. What do you notice about the lines?
- d. What is the solution? Where do the lines intersect? How many solutions exist?
- e. Is the system consistent or inconsistent? Are the equations dependent or independent?

3) $-x + y = -2$

$3x + y = 2$

- a. Solve graphically.
- b. Solve algebraically.
- c. What do you notice about the lines?
- d. What is the solution? Where do the lines intersect? How many solutions exist?
- e. Is the system consistent or inconsistent? Are the equations dependent or independent?

Solutions:

1. $2x + 3y = 9$

$-4x - 6y = -18$

- a. Solve graphically.

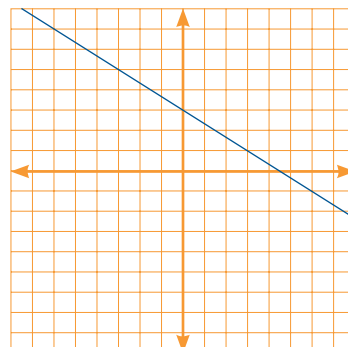

b. Multiply the first equation by 2 and add.

$$4x + 6y = 18$$

$$-4x - 6y = -18$$

$$0 = 0$$

There are infinitely many solutions.

c. The lines coincide.

d. The solution is all the points on the line. The lines intersect at every point on the line. There are infinitely many solutions.

e. The system is consistent and the equations are dependent.

2. $x - 2y = 8$

$$3x - 6y = 6$$

a. Solve graphically.

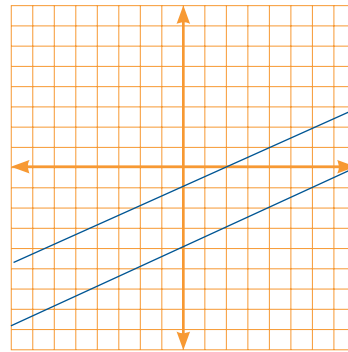

b. Multiply the first equation by -3 and add.

$$-3x + 6y = -24$$

$$3x - 6y = 6$$

$$0 = -18$$

There is no solution.

c. The lines are parallel.

d. There is no solution. The lines do not intersect.

e. The system is inconsistent and the equations are independent.

3. $-x + y = -2$

$$3x + y = 2$$

a. Solve graphically.

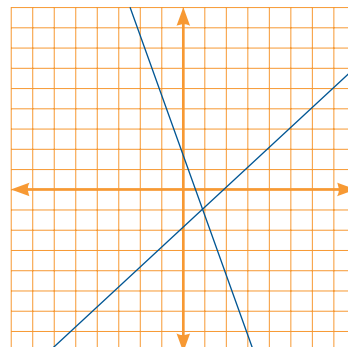

b. Multiply the first equation by -1 and add.

$$x - y = 2$$

$$3x + y = 2$$

$$4x = 4$$

$$x = 1$$

Substituting into equation 1 and solving for y,

$$-1 + y = -2$$

$$y = -1$$

The solution is (1, -1).

c. The lines intersect in one point.

d. The solution is (1, -1), the point where the lines intersect. There is one solution.

e. The system is consistent and the equations are independent.

INCLUDED IN THE STUDENT MANUAL

Task #4: Systems of Equations Practice Problems

Solve the following systems of equations by any method. Indicate if there is no solution or infinitely many solutions.

1. $2y - 4 = 0$

$$x + 2y = 5$$

2. $3x + 8y = 18$

$$x + 2y = 4$$

3. $2y - 4x = -4$

$$y = -2 + 2x$$

4. $2x - 4y = 5$

$$3x + 5y = 2$$

5. $f(x) = -4x + 15$

$$g(x) = 3x - 6$$

6. $3y = 6 + x$

$$3x - 9y = 9$$

7. $3x - 5y = 1$

$$7x - 8y = 17$$

8. $y = -\frac{3}{4}x$

$$3x + 2y = 6$$

Solutions:

1. (1, 2)

2. (-2, 3)

3. Infinitely many solutions.

4. $(\frac{3}{2}, -\frac{1}{2})$

5. (3, 3)

6. No solution

7. (7, 4)

8. (4, -3)

Have different groups share solutions. Be sure students are explaining and interpreting the reason for each step in the problem solving process. Students should include in this discussion the merits (or lack of) using different methods to find the solution.

Evaluate Understanding

Ask students to individually complete the pre-assessment task for the Classifying Solutions Formative Assessment Lesson they will be completing in the next lesson.

Introduce the task briefly, and tell the students to spend 15 minutes working individually, answering these questions. Ask them to show all work on the sheet, making sure to explain answers really clearly. It is important that students answer the questions without assistance as much as possible.

Collect these. This will give you, the teacher, an opportunity to assess the work and identify students who have misconceptions or need other forms of help. You will then be able to target your help more effectively in the follow-up lesson tomorrow.

Common issues that may arise while analyzing the student work and suggested feedback prompts can be found on page T-3 of the Classifying Solutions Formative Assessment Lesson (<http://map.mathshell.org/materials/download.php?fileid=1213>) and included in Lesson 3 of this manual.

Closing Activity



Depending on the level of understanding and fluency of your class, you may want to spend more time practicing one of the other problem sets listed in the Practice Together section above. If students have the mechanics down, have them work on a more challenging problem such as:

Shell Center MAP Assessment High School Task E14: Best Buy Tickets:

<http://map.mathshell.org/materials/tasks.php?taskid=286&subpage=expert>

INCLUDED IN THE STUDENT MANUAL

Task #5: Best Buy Tickets

Susie is organizing the printing of tickets for a show her friends are producing. She has collected prices from several printers and these two seem to be the best. Susie wants to go for the best buy. She doesn't yet know how many people are going to come. Show Susie a couple of ways in which she could make the right decision, whatever the number. Illustrate your advice with a couple of examples.

SURE PRINT
Ticket printing
25 tickets for \$2

BEST PRINT
Tickets printed
\$10 setting up
plus
\$1 for \$25 tickets

Best Buy Tickets	Rubric																						
	Points	Section points																					
Shows correct reasoning and calculations such as the following: <i>May solve using algebra</i>																							
Sure Print: The cost for n tickets in dollars is $C = \frac{2n}{25}$	2																						
Best print: $C = 10 + \frac{n}{25}$	2																						
Method 1: May draw graphs and find the point of intersection ($n = 250$).	4																						
Method 2 (algebraic)	or																						
When the two costs are equal $\frac{2n}{25} = 10 + \frac{n}{25}$ $n = 250$	4																						
Shows that when $n < 250$ Sure Print is cheaper When $n > 250$ Best Print is cheaper		10																					
Or <i>May decide to solve arithmetically</i>	or	or																					
Decides to list costs for different numbers of tickets.	2																						
<table border="1"> <thead> <tr> <th>Number of tickets</th> <th>Sure Print</th> <th>Best Print</th> </tr> </thead> <tbody> <tr> <td>50</td> <td>4</td> <td>12</td> </tr> <tr> <td>100</td> <td>8</td> <td>14</td> </tr> <tr> <td>150</td> <td>12</td> <td>16</td> </tr> <tr> <td>200</td> <td>16</td> <td>18</td> </tr> <tr> <td>250</td> <td>20</td> <td>20</td> </tr> <tr> <td>300</td> <td>24</td> <td>23</td> </tr> </tbody> </table>	Number of tickets	Sure Print	Best Print	50	4	12	100	8	14	150	12	16	200	16	18	250	20	20	300	24	23	5	
Number of tickets	Sure Print	Best Print																					
50	4	12																					
100	8	14																					
150	12	16																					
200	16	18																					
250	20	20																					
300	24	23																					
States that the lists show that when $n = 250$ the costs are equal.	1																						
States that when $n < 250$ Sure Print is cheaper When $n > 250$ Best Print is cheaper	2 x 1	10																					
Total Points		10																					

INCLUDED IN THE STUDENT MANUAL

Task #6: Dimes and Quarters and Sum of Digits

1) The only coins that Alexis has are dimes and quarters. Her coins have a total value of \$5.80. She has a total of 40 coins. How many does she have of each coin?

(<http://www.illustrativemathematics.org/illustrations/220>)

2) The sum of the digits of a two-digit number is seven. When the digits are reversed, the number is increased by 27. Find the number.

Stapel, Elizabeth. "System-of-Equations Word Problems." Purplemath. Available from <http://www.purplemath.com/modules/systprob.htm>. Accessed 17 September 2012

Possible Solutions:

1. Since each dime is worth ten cents and each quarter worth twenty-five cents, their total value would be $0.10d+0.25q$ which would total \$5.80.

$$0.10d+0.25q=5.80$$

The total number of dimes (d) and quarters (q) is 40.

$$d + q = 40$$

Solving the system, the number of dimes = 28 and the number of quarters = 12.

2. Use “t” for the “tens” digit of the original number and “u” for the “units” (or “ones”) digit. Keeping in mind that the tens digit stands for “ten times this value”, then:

$$t + u = 7$$

Just as “26” is “10 times 2, plus 6 times 1”, so also the two-digit number will be ten times the “tens” digit, plus one times the “units” digit.

$$\text{original number: } 10t + 1u$$

The new number will have the values of the digits (represented by the variables) in reverse order:

$$\text{new number: } 10u + 1t$$

And this new number is twenty-seven more than the original number:

(new number) is (old number) increased by (twenty-seven)

$$10u + 1t = 10t + 1u + 27$$

Now there is a system that can be solved:

$$t + u = 7$$

$$10u + t = 10t + u + 27$$

First simplify the second equation:

$$10u + t = 10t + u + 27$$

$$9u - 9t = 27$$

$$u - t = 3$$

After reordering the variables in the first equation, I now have:

$$u + t = 7$$

$$u - t = 3$$

Adding down, I get $2u = 10$, so $u = 5$. Then $t = 2$. Checking, this means that the original number was 25 and the new number (gotten by switching the digits) is 52. Since $52 - 25 = 27$, this solution checks out.

The number is 25.

Independent Practice:

If students need additional practice, you may want to assign more problems such as those found at the end of Practice Together Sections.

Linear Systems of Equations

Lesson 2 of 6

Formative Assessment Lesson: Classifying Solutions (0, 1 or infinitely many)

Description:

This lesson begins with a formative assessment lesson that assesses student understanding of properties of systems of equations based upon the number of solutions. Then followed with additional application problems.

Georgia Standards of Excellence Addressed:

- MGSE9-12.A.CED.2: Create linear, quadratic, and exponential equations in two or more variables to represent relationships between quantities; graph equations on coordinate axes with labels and scales. (The phrase “in two or more variables” refers to formulas like the compound interest formula, in which $A = P(1 + r/n)^{nt}$ has multiple variables.)
- MGSE9-12.A.CED.3: Represent constraints by equations or inequalities, and by systems of equations and/or inequalities, and interpret data points as possible (i.e. a solution) or not possible (i.e. a non-solution) under the established constraints.
- MGSE9-12.A.REI.6: Solve systems of linear equations exactly and approximately (e.g., with graphs), focusing on pairs of linear equations in two variables.
- MGSE9-12.F.IF.9: Compare properties of two functions each represented in a different way (algebraically, graphically, numerically in tables, or by verbal descriptions). For example, given a graph of one function and an algebraic expression for another, say which has the larger maximum.

Standard(s) for Mathematical Practice Emphasized:

- SMP 1: Make sense of problems and persevere in solving them.
- SMP 4: Model with mathematics.
- SMP 6: Attend to precision.

The following *Formative Assessment Lesson* is a classroom-ready lesson included to help teachers assess and improve students' understanding of mathematical concepts and skills and their ability to use the "mathematical practices" described in the College Readiness Standards. Research has shown that formative assessment, as embodied in the following lesson, is a powerful way to improve student learning and performance. This approach first allows students to demonstrate their prior understandings and abilities in employing the mathematical processes, and then resolve their own difficulties and misconceptions through structured discussion. This results in more secure long-term learning, reducing the need for re-teaching that otherwise takes so much classroom time. Many often ask, why don't students just remember the procedures they have been taught and practiced? The fact is, that approach works fine in the short term but, as every teacher knows, if procedural knowledge is not underpinned by conceptual understanding, students will quickly forget "how to do it." Read more about the *Formative Assessment Lesson* rationale, structure, and philosophy using the *Brief Guide for Teachers and Administrators* that can be found at <http://map.mathshell.org/materials/index.php>.

CONCEPT DEVELOPMENT

Mathematics Assessment Project
CLASSROOM CHALLENGES
A Formative Assessment Lesson

Classifying Solutions to Systems of Equations

Mathematics Assessment Resource Service
University of Nottingham & UC Berkeley
Beta Version

For more details, visit: <http://map.mathshell.org>
© 2012 MARS, Shell Center, University of Nottingham
May be reproduced, unmodified, for non-commercial purposes under the Creative Commons license
detailed at <http://creativecommons.org/licenses/by-nc-nd/3.0/> - all other rights reserved

BEFORE THE LESSON

Assessment task: Working with Linear Equations (15 minutes)

Ask the students do this task, in class or for homework, a day or more before the formative assessment lesson. This will give you an opportunity to assess the work and identify students who have misconceptions or need other forms of help. You will then be able to target your help more effectively in the follow-up lesson.

Give each student a copy of *Working with Linear Equations*.

Introduce the task briefly, and help the class to understand what they are being asked to do. You may want to explain to the class the term ‘common solution’.

Spend fifteen minutes working individually, answering these questions.

Show all your work on the sheet.

Make sure you explain your answers really clearly.

It is important that students answer the questions without assistance, as far as possible.

Working with Linear Equations

$\begin{array}{c c c c} x & -3 & 2 & 3 \\ \hline y & -3 & 7 & 9 \end{array}$	$\begin{array}{c c c c} x & 0 & 2 & 4 \\ \hline y & 5 & 7 & 9 \end{array}$	$\begin{array}{c c c c} x & -1 & 0 & 2 \\ \hline y & 5 & 1 & 7 \end{array}$	$\begin{array}{c c c c} x & -1 & 0 & 2 \\ \hline y & 1 & 3 & 7 \end{array}$
A	B	C	D

1a. Which of these tables of values satisfy the equation $y = 2x + 3$? Explain how you checked.

.....

.....

1b. By completing the table of values, draw the lines $y = 2x + 3$ and $x = 1 - 2y$ on the grid.

$y = 2x + 3$

x	-2	0		
y			5	

$x = 1 - 2y$

x	0		5	
y		0		

1c. Do the equations $y = 2x + 3$ and $x = 1 - 2y$ have one common solution, no common solutions, or infinitely many common solutions? Explain how you know.

.....

.....

2. Draw a straight line on the grid that has no common solutions with the line $y = 2x + 3$. What is the equation of your new line? Explain your answer.

.....

.....

Students should not worry too much if they cannot understand or do everything because you will teach a lesson using a similar task, which should help them. Explain to students that by the end of the next lesson, they should expect to answer questions such as these. This is their goal.

Assessing students' responses

Collect students' responses to the task. Make some notes on what their work reveals about their current levels of understanding and difficulties. The purpose of this is to forewarn you of the issues that will arise during the lesson, so that you can prepare carefully.

We suggest that you do not score students' work. The research shows that this is counterproductive, as it encourages students to compare scores and distracts their attention from how they may improve their mathematics.

Instead, help students to make further progress by asking questions that focus attention on aspects of their work. Some suggestions for these are given in the *Common issues* table on the next page. These have been drawn from common difficulties observed in trials of this unit.

We suggest that you write your own lists of questions, based on your students' work, using the ideas in the *Common issues* table. Preferably, write questions on each student's work, but if you do not have time for this, then prepare a few questions that apply to most students and write these on the board when the assessment task is revisited.

Common issues:	Suggested questions and prompts:
<p>Student assumes that only one of the tables satisfies the equation $y = 2x + 3$ (Q1) For example: The student selects only table A.</p>	<ul style="list-style-type: none"> • Are there more than three pairs of values that satisfy the equation $y = 2x + 3$? • Have you checked the values for x and y in each of the tables?
<p>Student makes an incorrect assumption about the multiplicative properties of zero (Q1 & Q2) For example: The student assumes $2 \times 0 + 3 = 5$. They then may select Table B as satisfying the equation $y = 2x + 3$ (Q1)</p>	<ul style="list-style-type: none"> • Is 4×0 the same as 4×1? • Use addition to figure out two multiplied by zero. [E.g. $0 + 0 = 0$.]
<p>Student applies the rules for multiplying negative numbers incorrectly (Q1 & Q2) For example: The student assumes $2 \times -1 + 3 = 5$ They then may select Table C as satisfying the equation $y = 2x + 3$ (Q1)</p>	<ul style="list-style-type: none"> • Is 3×-2 the same as 3×2?
<p>Student provides little or no explanation (Q1)</p>	<ul style="list-style-type: none"> • What method did you use when checking which tables satisfy the equation? Write what you did.
<p>Student incorrectly draws the graph For example: The student draws a non-linear graph.</p>	<ul style="list-style-type: none"> • On your graph, is the slope always the same? Does this agree with the equation of the graph? • How can you check you have plotted the graph correctly?
<p>Student uses guess and check to complete the tables of values (Q1b)</p>	<ul style="list-style-type: none"> • Can you think of a quicker method? • Would changing the subject of the equation help you figure out some of the values?
<p>Student states that the two equations, $y = 2x + 3$ and $x = 1 - 2y$ have no common solutions (Q1c) For example: The student fails to extend the line $x = 1 - 2y$ beyond the values in the table. This means the two lines do not intersect.</p>	<ul style="list-style-type: none"> • What does 'common solution' mean? • Are there any other points that satisfy the equation $x = 1 - 2y$? Plot some.
<p>Student provides little or no explanation (1c and 2)</p>	<ul style="list-style-type: none"> • Explain why you think your answer is correct.
<p>Student either does not plot a line that has no common solutions with the line $y = 2x + 3$ or plots it incorrectly (Q2)</p>	<ul style="list-style-type: none"> • Sketch two lines that have no common solutions. What property do they share? [The lines will be parallel.]
<p>Student uses guess and check to figure out the equation of the line (Q2)</p>	<ul style="list-style-type: none"> • Can you think of a quicker method? • What can you tell me about two lines with no common solution? Give me two equations that have no common solution.

SUGGESTED LESSON OUTLINE

Whole-class introduction (10 minutes)

Give each student a mini-whiteboard, pen, and eraser. Maximize participation in the discussion by asking all students to show you solutions on their mini-whiteboards.

Write the equation $y = 3x + 2$ on the board.

Ask the following questions in turn:

If $x = 5$ what does y equal? [17]

Ask students to explain how they arrived at their answer. If a variety of values are given within the class, discuss any common mistakes and explore different strategies.

If $x = -1$ what does y equal? [-1]

If students are struggling with multiplying by a negative number, ask the class to summarize the results of multiplying with positives and negatives. Some students may believe that because x and y are different letters, they have to take different values. Point out that here both x and y can both be equal to -1 .

If $y = 8$ what does x equal? [2]

If $y = 0$ what does x equal? [- $\frac{2}{3}$]

Students may either use guess and check or rearrange the equation in order to figure out the value for x . You may want to discuss these two strategies.

Students often think that they have made a mistake when they get an answer that is not a whole number. Discuss the value of checking an answer by substituting it back in as x , as well as emphasizing that not all solutions will be positive integers and that negative and fractional solutions can also occur.

It may also be appropriate to discuss the benefits of leaving answers in fraction form rather than converting to a decimal, especially when a recurring decimal will result. Provide an example of say, $\frac{1}{2}$, and discuss the difference between this fraction expressed as a decimal, and $-\frac{2}{3}$ expressed as a decimal, in terms of accuracy and rounding.

How can you check your answer? [By substituting it back in as x .]

How can you check that all your answers are correct? [Sketch the coordinates on a grid and see if they form a straight line.]

If students' work on the assessment task has highlighted issues with plotting points and making connections between solutions to a linear equation and points on a straight line graph, it may be appropriate to ask students to check that the solutions for the equation $y = 3x + 2$ form a straight line when plotted.

Explain to students that in the next activity they will be using their skills of substitution and solving equations to help them to investigate graphical representations of linear equations.

Collaborative activity: Card Set A: Equations, Tables & Graphs (20 minutes)

Organize students into pairs.

For each pair provide a cut up copy of *Card Set A: Equations, Tables & Graphs* and some plain paper.

These six cards each include a linear equation, a table of values and a graph. However, some of the information is missing.

In your pairs, share the cards between you and spend a few minutes, individually, completing them. You may need to do some calculations to complete the cards. Do these on the plain paper and be prepared to explain your method to your partner.

Once you have had a go at filling in the cards on your own, take turns to explain your work to your partner. Your partner should check your cards and challenge you if they disagree. It is important that you both understand and agree on the answers for each card.

When completing the graphs, take care to plot points carefully and make sure that the graph fills the grid in the same way as it does on Cards C1 and C3.

Slide P-1: Card set A: Equations, Tables, Graphs on the projector resource summarizes these instructions.

If students are struggling, suggest that they focus on Cards C4 and C5 first.

It does not matter if students are unable to complete all six cards. It is more important that they can confidently explain their strategies and have a thorough understanding of the skills they are using.

For students who complete all the cards successfully and need an extension, ask them to spend a few minutes comparing their completed cards:

Select two cards and note on your whiteboards any common properties of the equations and/or the graphs. Repeat this for all of your completed cards. This will help you later.

While students work in small groups you have two tasks: to make a note of students approaches to the task, and to support student reasoning.

Note student approaches to the task

Listen and watch students carefully and note any common mistakes. For example, are students misinterpreting the slope and intercept on cards where the graph has already been drawn? Do they fail to recognize an equation/graph that has a negative gradient? You may want to use the questions in the *Common issues* table to help address misconceptions.

Also notice the way in which students complete the cards. Do students use the completed table of values to plot the graph or do they use their knowledge of slope and intercept to draw the graph directly from the equation? Do students first plot the line using easy values for x or y , and then read off values from the graph in order to complete the table? Do students rearrange the equation or do they use guess and check to solve for x or y ? Do students use multiplication to eliminate the fraction from the equation? Do students use the slope and intercept or guess and check to figure out the equation of the graph?

You will be able to use this information in the whole-class discussion.

Support student reasoning

Try not to make suggestions that move students towards a particular strategy. Instead, ask questions to help students to reason together.

Martha completed this card. Jordan, can you explain Martha's work?

Show me a different method from your partner's to check their method is correct.

If you find the student is unable to answer this question, ask them to discuss the work further. Explain that you will return in a few minutes to ask a similar question.

How can you check the card is correct? [Read off coordinates from the line, use the slope and intercept to check the equation matches the line, etc.]

For each card, encourage students to explain their reasoning and methods carefully.

How do you know that $y = 3$ when $x = 2$ in Card C2? What method did you use?

How did you find the missing equation on Card C1/C3? Show me a different method.

Suppose you multiply out the equation on Card C4. What information can you then deduce about the graph? [The y -intercept and slope.]

Which of these equations is arranged in a way that makes it easy to draw a graph using information about the line's y -intercept and slope? [C5.] What are they? [4 and $-\frac{1}{2}$.]

You may find some students struggle when the slope of a line is negative or when dealing with negative signs, or when the slope is a fraction.

Checking work (10 minutes)

Ask students to exchange their completed cards with another pair of students.

Carefully check the cards and point out any answers you think are incorrect.

You must give a reason why you think the card is incorrect but do not make changes to the card.

Once students have checked another group's cards, they need to review their own cards taking into account comments from their peers and make any necessary changes.

Collaborative activity: Using Card Set B to link Card Set A (20 minutes)

Give each pair two copies of *Card Set B: Arrows* (already cut-up), a copy of *Graph Transparency*, a transparency pen, a large sheet of paper for making a poster, and a glue stick.

Choose two of your completed cards from Card Set A and stick them on your poster paper with a gap in between.

You are going to try and link these cards with one of the arrows.

The cards will either have no common solutions, one common solution or infinitely many common solutions. Select the appropriate arrow and stick it on your poster between the two cards. If the cards have one common solution, you will need to complete the arrow with the values of x and y where this solution occurs.

Add another completed card to your poster and compare it with the two already stuck down. Find arrows that link this third card with the other two and stick the cards down.

Continue to compare all the cards in this way, making as many links as possible. If some of the cards are incomplete, you will need to complete them before comparing them.

Slide P-2: *Card set B: Arrows* on the projector resource summarizes these instructions.

Some students might find it helpful to use a transparency when comparing the cards.

How might you use the Graph Transparency on your desk to help you to determine how many solutions the two cards have in common?

If students are struggling to identify how to use the transparency, ask them if tracing one of the graphs onto the transparency might be helpful. Some students may prefer to not to use the transparency.

Notice how students are working and their method for completing the task. Are any students relying purely on the algebraic representation of the equation? Once students have recognized that there is one common solution, are they checking the solution algebraically as well as using the graphs?

As students work on the comparisons, support them as before. Again you may want to use some of the questions in the *Common issues*. Walk around and ask students to explain their decisions.

The finished poster produced may look something like this:

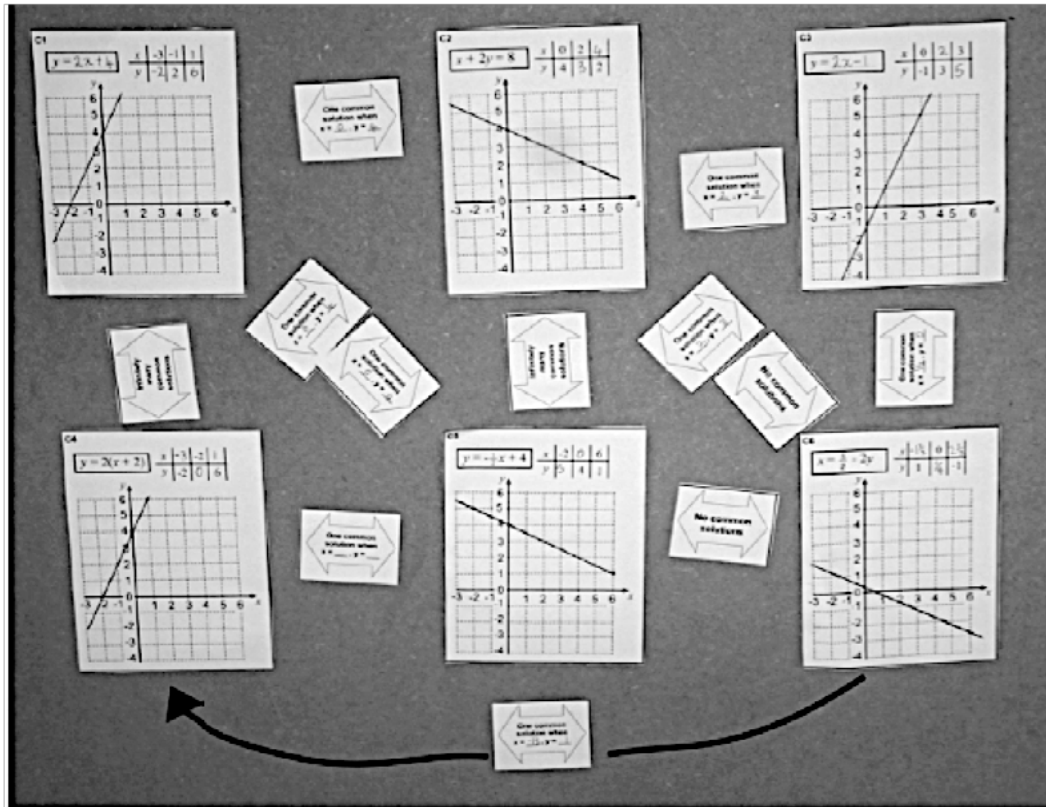

Whole-class discussion (15 minutes)

Once groups have completed their posters, display them at the front of the room. Based on what you have learned about your students' strategies and the review of their posters, select one or two groups to explain how they went about addressing the task (if possible select groups who have taken very different approaches to the task). As groups explain their strategies, ask if anyone has a question for the group or if anyone used a similar strategy.

When a few groups have had a chance to share their approach, consolidate what has been learned. Using mini-whiteboards to encourage all students to participate, ask the following questions in turn:

1. Show me two equations that have one common solution.
[E.g. $y = 2x + 4$ and $y = -\frac{1}{2}x + 4$.]
What are the solution values for x and y ? [$x = 0$ and $y = 4$.]
What happens to the graphs at this point? [They intersect each other.]
On your mini-whiteboards make up two more equations that have one common solution.
Don't use equations that appear on the cards. Sketch their graphs. Now show me!
2. Show me two equations that have no common solutions.
[E.g. $y = 2x + 4$ and $y = 2x - 1$.]
How do you know they have no common solution?
[They are parallel lines so will never intersect.]

*What do you notice about these two equations?
[They have the same coefficient of x /same slope.]
On your mini-whiteboards make up two more equations that have no common solutions.
Don't use equations that appear on the cards. Sketch their graphs. Now show me!*

3. *Show me two equations with infinitely many common solutions.
[E.g. $y = 2x + 4$ and $y = 2(x + 2)$.]
What do you notice about the two graphs for these equations? [They are the same line.]
Why is this? [$2(x + 2)$ is $2x + 4$ in factorized form.]*

The focus of this discussion is to explore the link between the graphical representations of the equations and their common solutions, even though students may have used both the algebraic representation and the table of values during the classification process. Help students to recognize that solutions to a system of two linear equations in two variables correspond to the points of intersection of their graphs, as well as what it means graphically when there are no or infinitely many common solutions.

Follow-up lesson: Working with Linear Equations (revisited) (15 minutes)

Give back the responses to the original assessment task to students and a copy of the task *Working with Linear Equations (revisited)*.

Ask students to look again at their solutions to the original task together with your comments. If you have not added questions to individual pieces of work then write your list of questions on the board. Students should select from this list only those questions they think are appropriate to their own work.

Look at your solutions to the original task Working with Linear Equations and read through the questions I have written.

Spend a few minutes thinking about how you could improve your work.

Using what you have learned, have a go at the second sheet: Working with Linear Equations (revisited).

Some teachers give this as a homework task.

SOLUTIONS

Assessment task: Working with Linear Equations

1a. Tables A and D satisfy the equation $y = 2x + 3$.

Table B satisfies the equation $y = x + 5$ and table C is non-linear.

b.

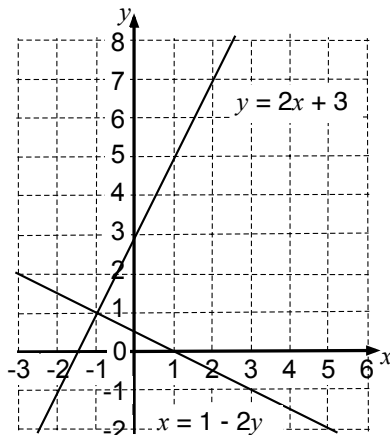

$$y = 2x + 3$$

x	-2	0	1
y	-1	3	5

$$x = 1 - 2y$$

x	0	1	5
y	0.5	0	-2

c. The two graphs have one common solution at $x = -1, y = 1$. This is the point of intersection of the two graphs.

2. Students can draw any line that has the same slope as $y = 2x + 3$. For example $y = 2x$ or $y = 2x + 1$ etc.

Lesson task: Card Sets A and B

The six cards in *Card Set A* describe the four straight lines below:

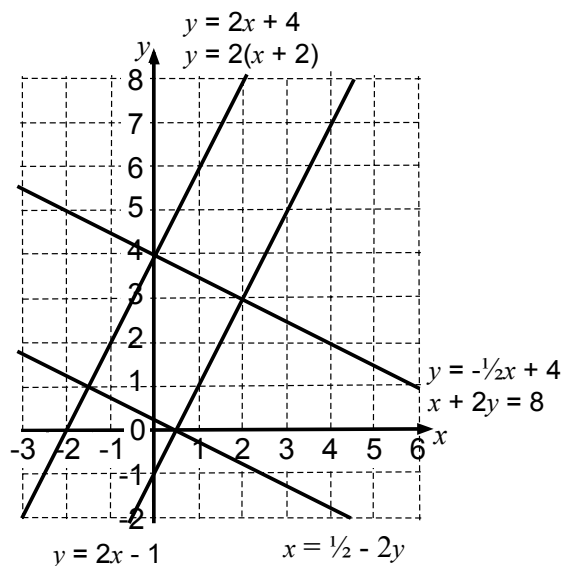

C1
 $y = 2x + 4$

$$\begin{array}{r} x & -3 & -1 & 1 \\ y & -2 & 2 & 6 \end{array}$$

C4
 $y = 2(x + 2)$

$$\begin{array}{r} x & -3 & -2 & 1 \\ y & -2 & 0 & 6 \end{array}$$

C2
 $x + 2y = 8$

$$\begin{array}{r} x & 0 & 2 & 4 \\ y & 4 & 3 & 2 \end{array}$$

C5
 $y = -\frac{1}{2}x + 4$

$$\begin{array}{r} x & -2 & 0 & 6 \\ y & 5 & 4 & 1 \end{array}$$

C3
 $y = 2x - 1$

$$\begin{array}{r} x & 0 & 2 & 3 \\ y & -1 & 3 & 5 \end{array}$$

C6
 $x = \frac{1}{2} - 2y$

$$\begin{array}{r} x & -1.5 & 0 & 2.5 \\ y & 1 & 0.25 & -1 \end{array}$$

Infinitely many common solutions

$x + 2y = 8$ and $y = -\frac{1}{2}x + 4$

$x + 2y = 8$ (C2) is a rearrangement of $y = -\frac{1}{2}x + 4$.

$y = 2(x + 2)$ and $y = 2x + 4$

$y = 2(x + 2)$ (C4) is the factorized form of $y = 2x + 4$.

No common solutions

$y = 2x + 4$ and $y = 2x - 1$

Equal slopes.

$y = -\frac{1}{2}x + 4$ and $x = \frac{1}{2} - 2y$

Equal slopes.

One common solution

$y = 2x + 4$ (or $y = 2(x + 2)$) and $y = -\frac{1}{2}x + 4$ (or $x + 2y = 8$) have one common solution at (0,4).

$y = 2x + 4$ (or $y = 2(x + 2)$) and $x = \frac{1}{2} - 2y$

have one common solution at (-1.5,1).

$y = 2x - 1$ and $y = -\frac{1}{2}x + 4$ (or $x + 2y = 8$)

have one common solution at (2,3).

$y = 2x - 1$ and $x = \frac{1}{2} - 2y$

have one common solution at (0.5,0).

Assessment task: Working with Linear Equations (revisited)

1a. Tables B and D satisfy the equation $y = 2x + 2$.

Table A is non-linear and table C satisfies the equation $y = 3x + 1$.

b.

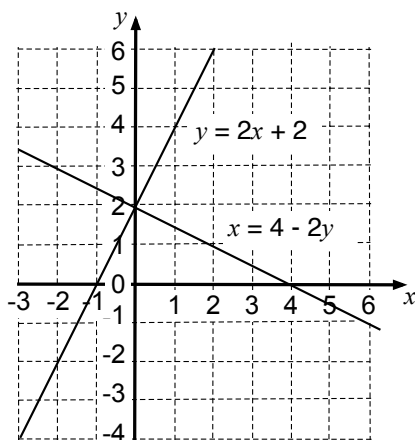

$y = 2x + 2$

$$\begin{array}{r} x & -3 & 0 & 2 \\ y & -4 & 2 & 6 \end{array}$$

$x = 4 - 2y$

$$\begin{array}{r} x & 2 & 4 & 6 \\ y & 1 & 0 & -1 \end{array}$$

c. The two graphs have one common solution at $x = 0, y = 2$. This is the point of intersection of the two graphs.

2. Students can draw any line that has the same slope as $y = 2x + 2$. For example $y = 2x$ or $y = 2x + 1$ etc.

Working with Linear Equations

x	-3	2	3
y	-3	7	9

A

x	0	2	4
y	5	7	9

B

x	-1	0	2
y	5	1	7

C

x	-1	0	2
y	1	3	7

D

1a. Which of these tables of values satisfy the equation $y = 2x + 3$? Explain how you checked.

.....

.....

.....

b. By completing the table of values, draw the lines $y = 2x + 3$ and $x = 1 - 2y$ on the grid.

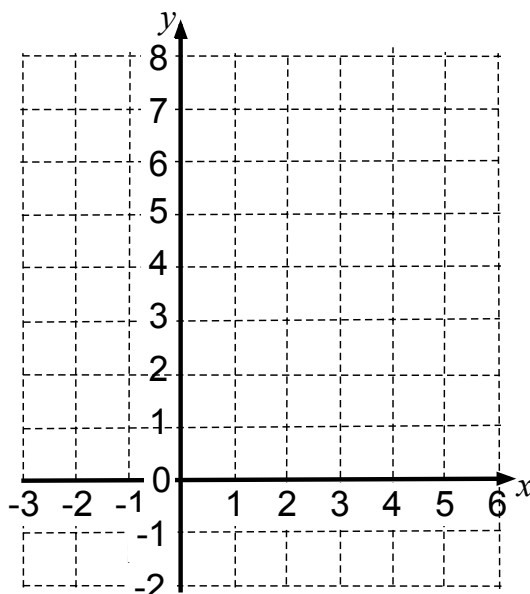

$$y = 2x + 3$$

x	-2	0	
y			5

$$x = 1 - 2y$$

x	0		5
y		0	

c. Do the equations $y = 2x + 3$ and $x = 1 - 2y$ have one common solution, no common solutions, or infinitely many common solutions? Explain how you know.

.....

.....

2. Draw a straight line on the grid that has no common solutions with the line $y = 2x + 3$. What is the equation of your new line? Explain your answer.

.....

Card Set A: Equations, Tables & Graphs

C1

$$y = \text{-----}$$

x	-3		1
y		2	

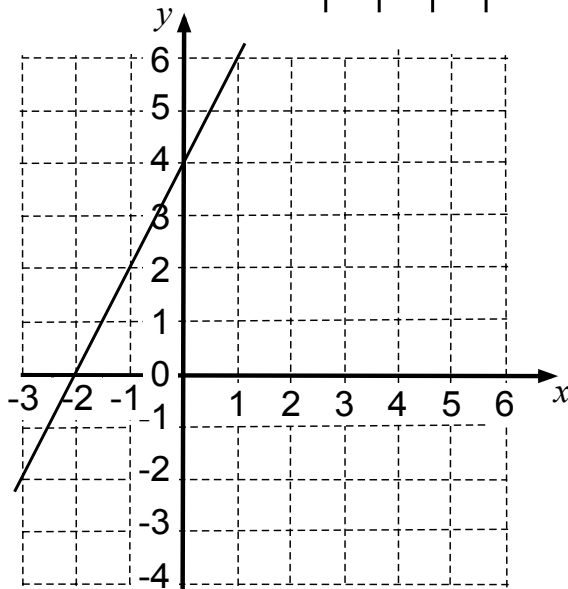

C2

$$x + 2y = 8$$

x	0	2	
y	4		2

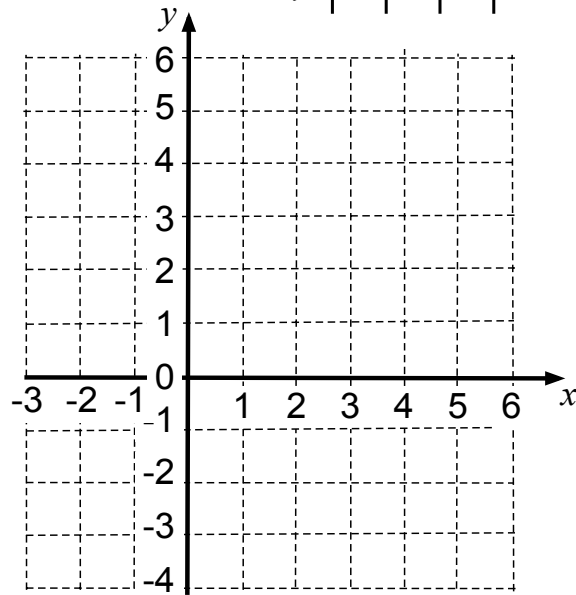

Card Set A: Equations, Tables & Graphs (continued)

C3

$y = \underline{\hspace{2cm}}$

x	0	3
y	-1	3

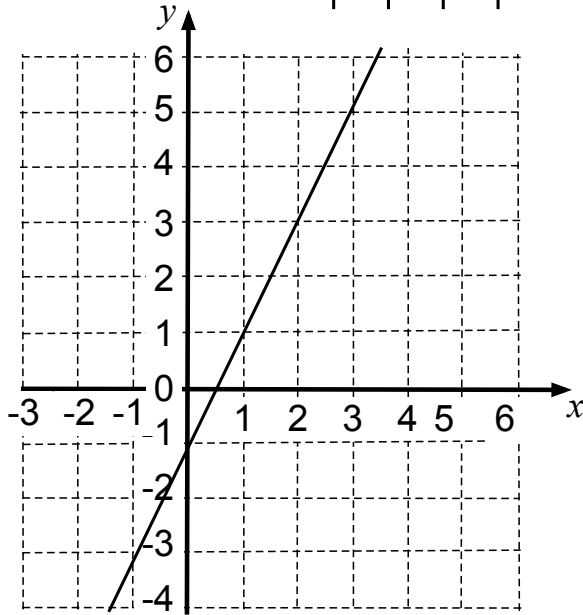

C4

$y = 2(x + 2)$

x	-2	6
y	-2	6

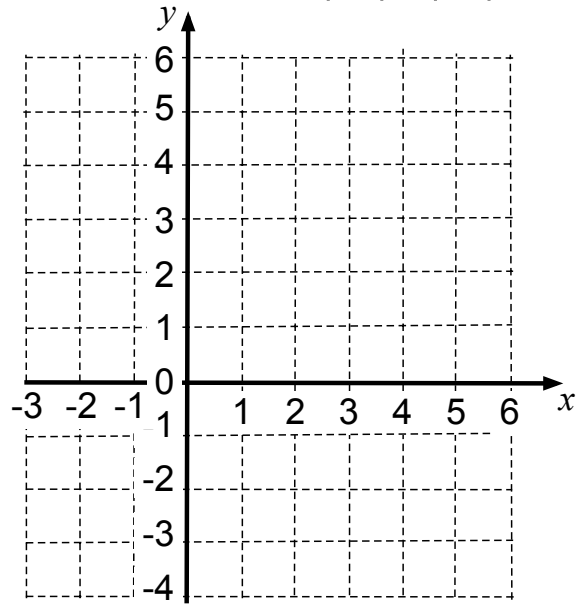

Card Set A: Equations, Tables & Graphs (continued 2)

C5

$y = -\frac{1}{2}x + 4$	x	-2		6
	y		4	

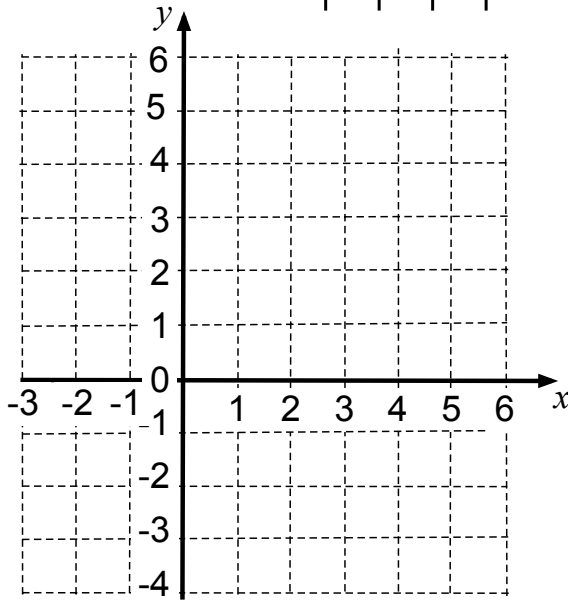

C6

$x = \frac{1}{2} - 2y$	x		0	
	y	1		-1

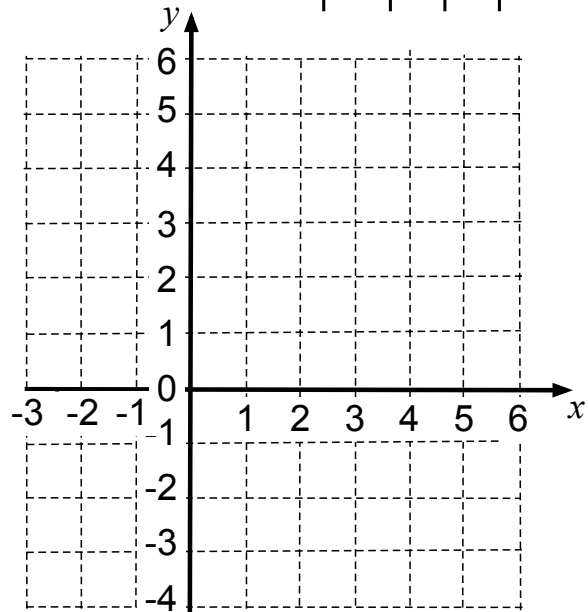

Card Set B: Arrows

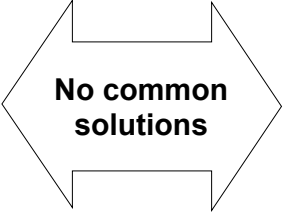
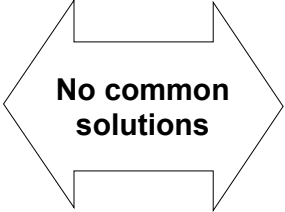
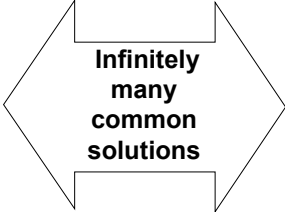
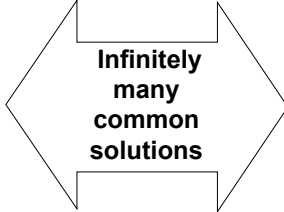
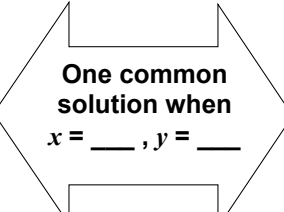
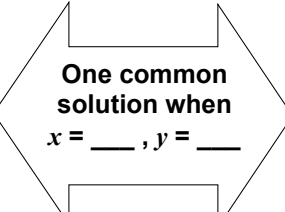
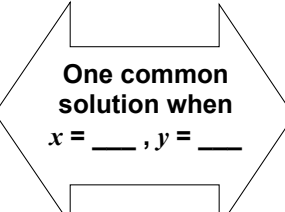
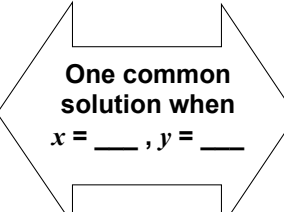
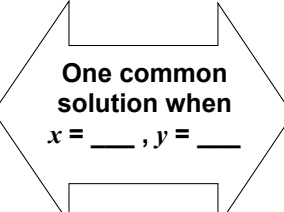
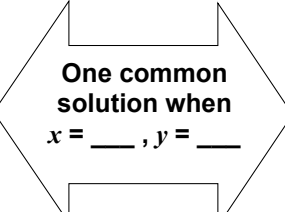
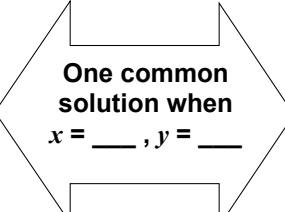
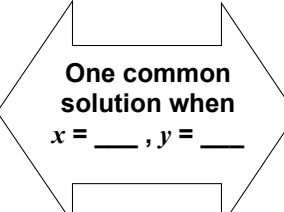
 <p>No common solutions</p>	 <p>No common solutions</p>	 <p>Infinitely many common solutions</p>	 <p>Infinitely many common solutions</p>
 <p>One common solution when $x = \underline{\quad}, y = \underline{\quad}$</p>	 <p>One common solution when $x = \underline{\quad}, y = \underline{\quad}$</p>	 <p>One common solution when $x = \underline{\quad}, y = \underline{\quad}$</p>	 <p>One common solution when $x = \underline{\quad}, y = \underline{\quad}$</p>
 <p>One common solution when $x = \underline{\quad}, y = \underline{\quad}$</p>	 <p>One common solution when $x = \underline{\quad}, y = \underline{\quad}$</p>	 <p>One common solution when $x = \underline{\quad}, y = \underline{\quad}$</p>	 <p>One common solution when $x = \underline{\quad}, y = \underline{\quad}$</p>

Graph Transparency

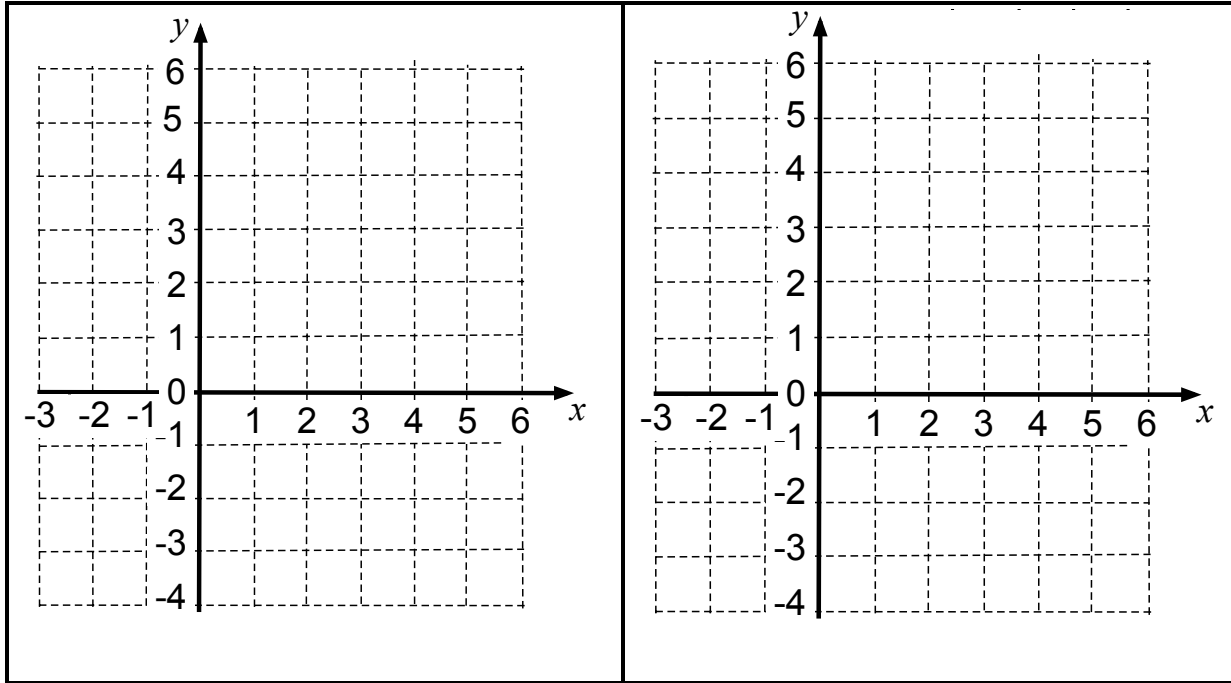

Working with Linear Equations (revisited)

x	0	1	2
y	4	4	5

A

x	1	2	3
y	4	6	8

B

x	-2	-1	1
y	-5	-2	4

C

x	-2	-1	1
y	-2	0	4

D

- 1a. Which of these tables of values satisfy the equation $y = 2x + 2$? Explain how you checked.

.....

.....

.....

- b. By completing the table of values, draw the lines $y = 2x + 2$ and $x = 4 - 2y$ on the grid.

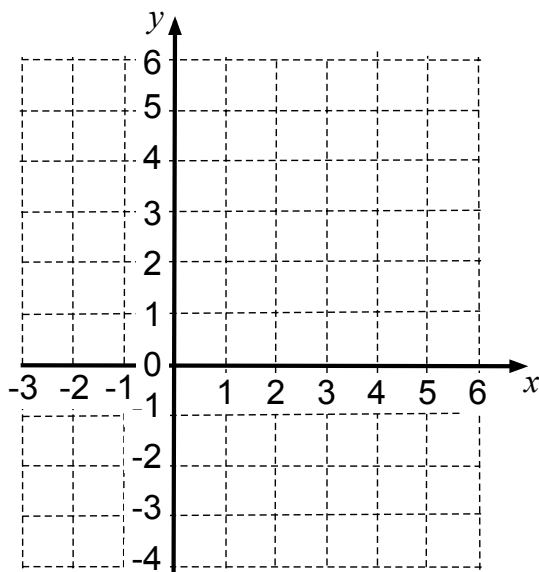

$$y = 2x + 2$$

x	-3	0	
y			6

$$x = 4 - 2y$$

x		4	6
y	1		

- c. Do the equations $y = 2x + 2$ and $x = 4 - 2y$ have one common solution, no common solutions, or infinitely many common solutions? Explain how you know.

.....

.....

2. Draw a straight line on the grid that has no common solutions with the line $y = 2x + 2$. What is the equation of your new line? Explain your answer.

.....

.....

Card Set A: Equations, Tables, Graphs

1. Share the cards between you and spend a few minutes, individually, completing the cards so that each has an equation, a completed table of values and a graph.
2. Record on paper any calculations you do when completing the cards. Remember that you will need to explain your method to your partner.
3. Once you have had a go at filling in the cards on your own:
 - Explain your work to your partner.
 - Ask your partner to check each card.
 - Make sure you both understand and agree on the answers.
4. When completing the graphs:
 - Take care to plot points carefully.
 - Make sure that the graph fills the grid in the same way as it does on Cards C1 and C3.

Make sure you both understand and agree on the answers for every card.

Card Set B: Arrows

1. You are going to link your completed cards from *Card Set A* with an arrow card.
2. Choose two of your completed cards and decide whether they have no common solutions, one common solution or infinitely many common solutions. Select the appropriate arrow and stick it on your poster between the two cards.
3. If the cards have one common solution, complete the arrow with the values of x and y where this solution occurs.
4. Now compare a third card and choose arrows that link it to the first two. Continue to add more cards in this way, making as many links between the cards as possible.

Mathematics Assessment Project
CLASSROOM CHALLENGES

This lesson was designed and developed by the
Shell Center Team
at the
University of Nottingham
Malcolm Swan, Nichola Clarke, Clare Dawson, Sheila Evans
with
Hugh Burkhardt, Rita Crust, Andy Noyes, and Daniel Pead

It was refined on the basis of reports from teams of observers led by
David Foster, Mary Bouck, and Diane Schaefer
based on their observation of trials in US classrooms
along with comments from teachers and other users.

This project was conceived and directed for
MARS: Mathematics Assessment Resource Service
by
Alan Schoenfeld, Hugh Burkhardt, Daniel Pead, and Malcolm Swan
and based at the University of California, Berkeley

We are grateful to the many teachers, in the UK and the US, who trialed earlier versions
of these materials in their classrooms, to their students, and to
Judith Mills, Carol Hill, and Alvaro Villanueva who contributed to the design.

This development would not have been possible without the support of
Bill & Melinda Gates Foundation
We are particularly grateful to
Carina Wong, Melissa Chabran, and Jamie McKee

© 2012 MARS, Shell Center, University of Nottingham
This material may be reproduced and distributed, without modification, for non-commercial purposes,
under the Creative Commons License detailed at <http://creativecommons.org/licenses/by-nc-nd/3.0/>
All other rights reserved.
Please contact map.info@mathshell.org if this license does not meet your needs.

Practice Together in Small Groups/Individually

Have students work individually or in groups on questions found in the worksheet Systems of Linear Equations.

INCLUDED IN THE STUDENT MANUAL

Task #7: Systems of Linear Equations Practice

1. An appliance store sells a washer-dryer combination for \$1,500. If the washer costs \$200 more than the dryer, find the cost of each appliance.
2. A particular computer takes 43 nanoseconds to carry out five sums and seven products. It takes 36 nanoseconds to carry out four sums and six products. How long does the computer take to carry out one sum? To carry out one product?
3. Two angles are supplementary if the sum of their measures is 180° . If one angle's measure is 90° more than twice the measure of the other angle, what are the measures of the angles?
4. Guess the number. The number has two digits. The sum of the digits is eight. If the digits are reversed, the result is 18 less than the original number. What is the original number?
5. Samantha took out two loans totaling \$6,000 to pay for her first year of college. She borrowed the maximum amount she could at 3.5% simple annual interest and the remainder at 7% simple annual interest. At the end of the first year, she owed \$259 in interest. How much was borrowed at each rate?

Possible Solutions:

1. An appliance store sells a washer-dryer combination for \$1,500. If the washer costs \$200 more than the dryer, find the cost of each appliance.

Let w = the cost of a washer.

Let d = the cost of a dryer.

$$w + d = 1500$$

$$w = d + 200$$

Substituting the second equation into the first equation:

$$(d + 200) + d = 1500$$

$$2d + 200 = 1500$$

$$2d = 1300$$

$$d = 650$$

$$w = 650 + 200 = 850$$

A washer costs \$850 and a dryer costs \$650.

2. A particular computer takes 43 nanoseconds to carry out five sums and seven products. It takes 36 nanoseconds to carry out four sums and six products. How long does the computer take to carry out one sum? To carry out one product?

Let x = time for the computer to carry out one sum.

Let y = time for the computer to carry out one product.

$$5x + 7y = 43$$

$$4x + 6y = 36$$

Multiply the first equation by -4 and the second equation by 5, then add:

$$-20x - 28y = -172$$

$$20x + 30y = 180$$

$$2y = 8$$

$$y = 4$$

$$5x + 7(4) = 43$$

$$5x + 28 = 43$$

$$5x = 15$$

$$x = 3$$

It takes the computer three nanoseconds to carry out one sum and four nanoseconds to carry out one product.

3. Two angles are supplementary if the sum of their measures is 180° . If one angle's measure is 90° more than twice the measure of the other angle, what are the measures of the angles?

Let x = measure of the smaller angle.

Let y = the measure of the larger angle.

$$x + y = 180$$

$$y = 2x + 90$$

Substituting the second equation into the first equation,

$$x + (2x + 90) = 180$$

$$3x + 90 = 180$$

$$3x = 90$$

$$x = 30$$

$$y = 2(30) + 90 = 60 + 90 = 150$$

The measures of the angles are 30° and 150° .

4. Guess the number. The number has two digits. The sum of the digits is eight. If the digits are reversed, the result is 18 less than the original number. What is the original number?

Let x = the tens digit

Let y = the units digit

The second condition leads to the equation:

$$10x + y - 18 = x + 10y$$

$$9x - 9y = 18$$

$$x - y = 2$$

So the system of equations is:

$$x + y = 8$$

$$x - y = 2$$

Adding the equations results in:

$$2x = 10$$

$$x = 5$$

$$5 + y = 8$$

$$y = 3$$

The original number is 53.

5. Samantha took out two loans totaling \$6,000 to pay for her first year of college. She borrowed the maximum amount she could at 3.5% simple annual interest and the remainder at 7% simple annual interest. At the end of the first year, she owed \$259 in interest. How much was borrowed at each rate?

Let x = the amount borrowed at 3.5% simple annual interest.

Let y = the amount borrowed at 7% simple annual interest.

$$x + y = 6000$$

$$0.035x + 0.07y = 259$$

Multiply the first equation by -0.035 and add the equations:

$$-0.035x - 0.035y = -210$$

$$0.035x + 0.07y = 259$$

$$0.035y = 49$$

$$y = 1400$$

$$x + 1400 = 6000$$

$$x = 4600$$

Samantha borrowed \$4,600 at 3.5% simple annual interest and \$1,400 at 7% simple annual interest.

Depending on student performance levels, you may choose to do some or all of these problems.

Evaluate Understanding

INCLUDED IN THE STUDENT MANUAL

Task #8: How Many Solutions?

Consider the equation $5x - 2y = 3$. If possible, find a second linear equation to create a system of equations that has:

- Exactly one solution.
- Exactly two solutions.
- No solutions.
- Infinitely many solutions.

Bonus Question: In each case, how many such equations can you find?

(<http://www.illustrativemathematics.org/illustrations/554>)

Possible Solutions:

Reasoning About Solutions

1. While it is possible to solve this problem purely algebraically, thinking about how the question relates to the graphs of the equations makes the problem much easier to solve. To have exactly one solution, we want the graph of $5x - 2y = 3$ and the graph of the equation we come up with to intersect at exactly one point, as shown below.

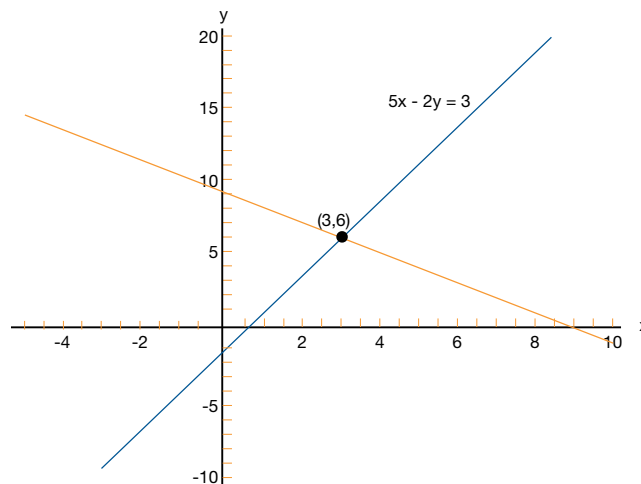

To do this, we find a point on the line $5x - 2y = 3$ and create another line that also contains that point but is not the same line. We can pick any value for x and find the corresponding value for y . Arbitrarily, let us consider $x = 3$. By substitution, we see that

$$5(3) - 2y = 3$$

$$15 - 2y = 3$$

$$y = 6$$

So $(3, 6)$ is a point on the graph of $5x - 2y = 3$. Now we find any values a , b , or c in the equation $ax + by = c$ that “work” with $x = 3$ and $y = 6$ and are not the same values as in the given equation. There are many possible ways to do this. For example, if we choose $a = 1$ and $b = 1$, then

$$x + y = 3 + 6 = 9$$

So c must be 9. In other words, $(3,6)$ is a solution to the equation

$$x + y = 9$$

Taking the two equations together as a system of equations—

$$5x - 2y = 3$$

$$x + y = 9$$

we can verify algebraically that there is exactly one solution to this system, namely $(3,6)$.

- To have exactly two solutions, we would want a second line that intersects the graph of $5x - 2y = 3$ at exactly two points. However, this is not possible. Since two points determine one and only one line, we must conclude that if two lines intersect at two points, they must actually be the same line.
- To have no solutions, we want our new line and the graph of $5x - 2y = 3$ to not intersect anywhere, meaning that the two lines are parallel. Consider any equation of the form $5x - 2y = c$ where $c \neq 3$, for example $5x - 2y = 7$. Then our corresponding system of equations is

$$5x - 2y = 3$$

$$5x - 2y = 7$$

From this we can see that no matter what values of x and y we substitute into the two equations, $5x - 2y$ can never equal 3 and 7 simultaneously, meaning that no point (x,y) can be on both lines at the same time. So, this system of equations has no solutions.

Graphically we can think of two lines with the same slope but different y -intercepts.

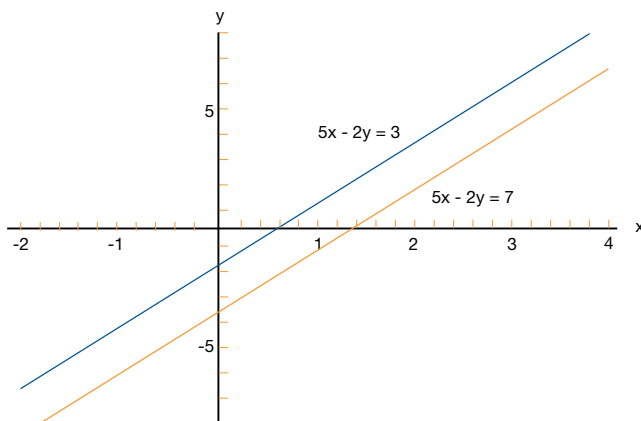

- To have infinitely many solutions, we want our equation and $5x - 2y = 3$ to intersect everywhere. In other words, they will be the same line. One way to denote this is to simply use the same equation, $5x - 2y = 3$, or just multiply both sides of the equation by a constant; let's say we multiply each term by 2. Then for the system of equations

$$5x - 2y = 3$$

$$10x - 4y = 6$$

any x and y pair that satisfies the first equation will satisfy the second, since taking two numbers that are equal and multiplying them both by 2 will result in two equal numbers. So this system has infinitely many solutions, as the equations both correspond to the same line and lines have infinitely many points.

Bonus

In parts (a), (c), and (d), there are infinitely many equations that can be found. In part (a), the point/solution (3,6) was arbitrary, and we could have picked any point, on the given line and drawn a line through the point at any slope. In part (c), we could have chosen any constant (other than 3) to take the place of the 3, and it would have still resulted in a system with no solutions. In part (d), we could have multiplied the terms of the given equation by any constant (besides 0) and it would have described the same line, though the equation would look different, resulting in infinitely many solutions to the corresponding system of equations. However, the graphs of the different equations in (d) would all look identical.

Closing Activity

Have students work either individually or in groups on the following activity.

INCLUDED IN THE STUDENT MANUAL

Task #9: Zoo

To enter a zoo, adult visitors must pay \$5, whereas children and seniors pay only half price. On one day, the zoo collected a total of \$765. If the zoo had 223 visitors that day, how many half-price admissions and how many full-price admissions did the zoo collect?

Solution:

To enter a zoo, adult visitors must pay \$5, whereas children and seniors pay only half price. On one day, the zoo collected a total of \$765. If the zoo had 223 visitors that day, how many half-price admissions and how many full-price admissions did the zoo collect?

Let x = the number of adult visitors paying full price.

Let y = the number of children and seniors paying half-price.

$$x + y = 223$$

$$5x + 2.5y = 765$$

Multiply the first equation by -2.5 and add the equations.

$$-2.5x - 2.5y = -557.5$$

$$5x + 2.5y = 765$$

$$2.5x = 207.5$$

$$x = 83$$

$$83 + y = 223$$

$$y = 140$$

There were 83 adult visitors paying full price and 140 children and senior visitors paying half-price.

Independent Practice:

Have students complete the closing activity.

Linear Systems of Equations

Lesson 3 of 6

Applications of Linear Systems of Equations

Description:

This lesson presents real-life applications of solving systems of equations and finding equations for lines in a given context.

Georgia Standards of Excellence Addressed:

- MGSE9-12.A.CED.2: Create linear, quadratic, and exponential equations in two or more variables to represent relationships between quantities; graph equations on coordinate axes with labels and scales. (The phrase “in two or more variables” refers to formulas like the compound interest formula, in which $A = P(1 + r/n)^{nt}$ has multiple variables.)
- MGSE9-12.A.CED.3: Represent constraints by equations or inequalities, and by systems of equations and/or inequalities, and interpret data points as possible (i.e. a solution) or not possible (i.e. a non-solution) under the established constraints.
- MGSE9-12.A.REI.6: Solve systems of linear equations exactly and approximately (e.g., with graphs), focusing on pairs of linear equations in two variables.

Standard(s) for Mathematical Practice Emphasized:

- SMP 2: Reason abstractly and quantitatively.
- SMP 4: Model with mathematics.
- SMP 6: Attend to precision.

Sequence of Instruction

Activities Checklist

Engage



Today’s lesson is meant to present real-life applications of solving systems of equations and finding equations for lines in context. The first context is supply-and-demand problems from business where students will:

- Find linear equations for a given set of supply and demand data.
- Find the equilibrium point for a system of supply and demand equations.
- Translate between table, graph and equation representations for supply and demand data.

Work with students to complete Part I: BurgerRama Cartoon Dolls in the Supply and Demand lesson found at: <http://illuminations.nctm.org/LessonDetail.aspx?id=L382>

Important Concepts:

The teacher may wish to acquaint students with the following concepts at the beginning of the activity session.

The quantity of merchandise that a merchant has available to sell is called the supply. The supply may be affected by storage space, speed of manufacture, or general availability of a product from the merchant’s supplier. Increasing the price of a product tends to increase the supply. The more expensive the product is to the consumer, the more willing manufacturers are to produce it. An increased price may slow the consumption of the product and thus also increase supply.

The quantity of merchandise that consumers wish to buy is called the demand. Price also affects demand. A lower price tends to increase the demand, and a higher price tends to decrease the demand.

When supply is greater than demand, the merchant suffers. The merchant has a stockpile of merchandise in which the customers are not interested. The merchant’s inventory is up, storage space is being used, and merchandise is not selling. When the demand is greater than the supply, the merchant may also suffer. The customers are willing to buy; however, the merchant cannot furnish enough merchandise for them. The merchant may lose customers and consequently lose sales.

The merchant is best served when supply and demand are in equilibrium. This situation occurs when a price is found that makes supply and demand equal each other.

INCLUDED IN THE STUDENT MANUAL

Task #10: Part I: BurgerRama Cartoon Dolls

Joan King is marketing director for the BurgerRama restaurant chain. BurgerRama has decided to have a cartoon-character doll made to sell at a premium price at participating BurgerRama locations. The company can choose from several different versions of the doll that sell at different prices. King’s problem is to decide which selling price will best suit the needs of BurgerRama’s customers and store managers. King has data from previous similar promotions to help her make a decision.

Selling Price of Each Doll	Number Supplied per Week per Store	Number Requested per Week per Store
\$1.00	35	530
\$2.00	130	400
\$4.00	320	140

1. Use the data from the table above to plot points representing selling price and supply price on a graph. (Selling Price of Each Doll should appear on the x-axis, and Number of Dolls Per Week per Store should appear on the y-axis.) Draw the line through the data points and write the word “Supply” on this line.
2. Plot points representing selling price and number requested (demand) on the same graph. Draw the line through these points. Write the word “Demand” on this line.
3. Use your graph to answer the following questions.
 - a. If King sets the price at \$2.50 per doll, how many disappointed customers will each store have during the week?
 - b. If King sets the price at \$3.80 per doll, how many unsold dolls will remain at each store at the end of a week?

- c. According to this graph, if the company could give the dolls away, how many would each store need per week?
 - d. According to this graph, what price would make the doll supply so tight that the average number available to each store would be zero?
 - e. Estimate the price where supply and demand will be in equilibrium.
4. Complete the following using equations:
- a. Use two of the points given to find the equation for supply (S) as a function of price (P).
 - b. Use two of the points given to find the equation for demand (D) as a function of price (P).
 - c. Solve the system of supply-and-demand equations to find the price in exact equilibrium. How does this price compare with your answer in question 3e above?

Explore

For more independent application of real-life scenarios, students should work together in groups of two or three to work through the worksheet Systems Equations Problems. As students are working, walk around and observe the students who are solving the problems using systems of equations and those that are not. Periodically stop and ask a student to explain his or her thinking to help students get on the right track.

INCLUDED IN THE STUDENT MANUAL

Task #11: Solving Problems with Two or More Equations

- Which is the better value when renting a vehicle? Show your work or explain your answer.
Rent-A-Hunk o' Junk charges \$29.95 per day and 43¢ per mile.
Tom's Total Wrecks charges \$45 per day plus 32¢ per mile.
- A landscaping company placed two orders with a nursery. The first order was for 13 bushes and four trees, and totaled \$487. The second order was for six bushes and two trees, and totaled \$232. The bills do not list the per-item price. What were the costs of one bush and of one tree? Show your work or explain your answer.
- Below is data on four cyclists riding along a road through the Black Hills. The variable x represents the time the cyclist has been riding and y represents the cyclist's distance in kilometers from Rapid City. Not all of the cyclists started their ride at Rapid City, but all of them left at the same time and are riding in the same direction.

Dan:

Hours	Kilometers
1	70
4	145

Maria:

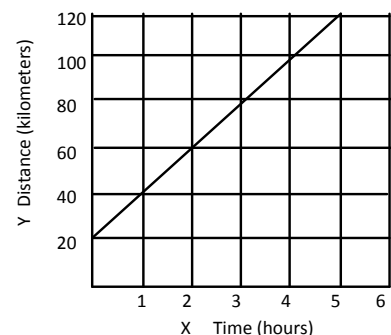

Ryan: $y = 30x$.

Helen: Started cycling 15 kilometers from Rapid City and traveled 50 kilometers in two hours.

- Who is cycling the fastest? Who is cycling the slowest? Explain.
- Will Ryan pass Dan? If so, when?
- Will Helen pass Maria? If so, when?
- Will Helen pass Dan? If so, when?
- Write a linear equation for each of the cyclists. Graph the equations using graph paper or a graphing calculator. Explain how the graphs relate to your answers above.

Solving Problems with Two or More Equations Solutions

- Which is the better value when renting a vehicle? Show your work and explain your answer.

Rent-A-Hunk o' Junk charges \$29.95 per day and 43¢ per mile.

Tom's Total Wrecks charges \$45 per day plus 32¢ per mile.

Let m = the number of miles driven.

Let c = the cost to rent the vehicle.

Rent-A-Hunk: $c = 29.95 + 0.43m$

Tom's Total Wrecks: $c = 45 + 0.32m$

Equating the two expressions for c ,

$$29.95 + 0.43m = 45 + 0.32m$$

$$0.11m = 15.05$$

$$m = 136.8$$

Rent-A-Hunk will be a better value if you drive less than 136.8 miles and Tom's Total Wrecks will be the better value if you drive more than 136.8 miles.

- A landscaping company placed two orders with a nursery. The first order was for 13 bushes and four trees, and totaled \$487. The second order was for six bushes and two trees, and totaled \$232. The bills do not list the per-item price. What were the costs of one bush and of one tree?

Let b = the cost of a bush and t = the cost of a tree.

First order: $13b + 4t = 487$

Second order: $6b + 2t = 232$

Multiplying the second equation by -2 , then adding:

$$13b + 4t = 487$$

$$-12b - 4t = -464$$

$$b = 23$$

$$t = 47$$

Bushes cost \$23 each; trees cost \$47 each.

3. Below is data on four cyclists riding along a road through the Black Hills. The variable x represents the time the cyclist has been riding and y represents the cyclist's distance in kilometers from Rapid City. Not all of the cyclists started their ride at Rapid City, but all of them left at the same time and are riding in the same direction.

Dan:

Hours	Kilometers
1	70
4	145

Maria:

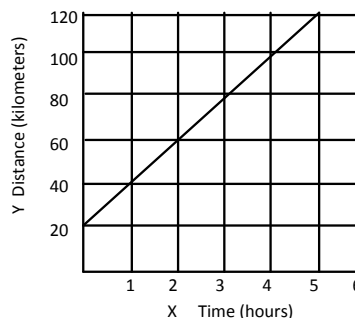

Ryan: $y = 30x$

Helen: Started cycling 15 kilometers from Rapid City and traveled 50 kilometers in two hours.

- a) Who is cycling the fastest? Who is cycling the slowest? Explain.

Find the slope for each driver.

Dan: $m = \frac{145 - 70}{4 - 1} = \frac{75}{3} = 25\text{kph}$

Maria: $m = 20\text{kph}$ (from graph)

Ryan: $m = 30\text{kph}$

Helen: $m = \frac{50}{2} = 25\text{kph}$

Ryan is cycling the fastest because he has the greatest slope.

Maria is cycling the slowest because she has the smallest slope.

- b) Will Ryan pass Dan? If so, when?

One way to solve this problem is to find the equation of the line for each cyclist.

Ryan: $y = 30x$

Dan: $m = 25$ and the line passes through the point $(1, 70)$

$$y - 70 = 25(x - 1)$$

$$y - 70 = 25x - 25$$

$$y = 25x + 45$$

Now find the point of intersection of the two lines.

$$30x = 25x + 45$$

$$5x = 45$$

$$x = 9$$

Ryan will pass Dan after cycling for nine hours.

- c) Will Helen pass Maria? If so, when?

One way to solve this problem is to find the equation of the line for each cyclist.

Helen: $m = 25$ and the y -intercept is 15

$$y = 25x + 15$$

Maria: $m = 20$ and the y -intercept is 20

$$y = 20x + 20$$

Now find the point of intersection of the two lines.

$$25x + 15 = 20x + 20$$

$$5x = 5$$

$$x = 1$$

Helen will pass Maria after cycling for one hour.

- d) Will Helen pass Dan? If so, when?

Dan: $y = 25x + 45$

Helen: $y = 25x + 15$

Now find the point of intersection of the two lines.

$$25x + 45 = 25x + 15$$

$$30 = 0$$

No solution.

Helen will not pass Dan. Dan started farther from Rapid City than Helen and they are traveling at the same speed.

- e) Write a linear equation for each of the cyclists. Graph the equations using graph paper or a graphing calculator. Explain how the graphs relate to your answers above.

Equations of lines were derived in the previous parts.

Dan: $y = 25x + 45$ (orange)

Ryan: $y = 30x$ (green)

Maria: $y = 20x + 20$ (blue)

Helen: $y = 25x + 15$ (gray)

- a. Green line is the steepest so Ryan is cycling the fastest.

Blue line is the flattest so Maria is cycling the slowest.

- b. The green line intersects the orange line at $(9, 270)$, so Dan will pass Ryan after cycling for nine hours.

- c. The blue line intersects the gray line at $(1, 40)$, so Helen will pass Maria after one hour of cycling.

- d. The orange and gray lines are parallel so Helen will never pass Dan.

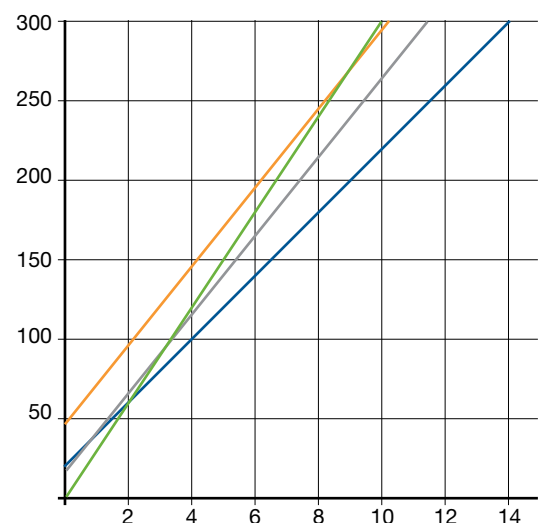

Explanation

As students are working in pairs, look for students who are making common errors or solving in non-traditional ways. Ask them to share what they did and lead a class discussion about how to get to the solution.

Lead class discussion around setting up equations and solving the resulting system of equations.

Practice Together in Small Groups/Individually

Have students complete remaining exercises from Supply and Demand. (Part II: Video Games and Part III: Silver Dollars if needed <http://illuminations.nctm.org/LessonDetail.aspx?id=L382>)

INCLUDED IN THE STUDENT MANUAL

Task #12: Part II: Video Games

The data provided in the table below show the supply and demand for video games at a toy warehouse.

Price	Supply	Demand
\$20	150	500
\$30	250	400
\$50	450	200

1. Find the supply equation.
2. Find the demand equation.
3. Find the price in equilibrium.

Point out to students that they have used three different ways to display, use, and discuss the information given in Part I: Burgerama Cartoon Dolls. The data were presented to them in a table. They used these data to construct a graph that allowed them to understand more about the problem. Then they used algebraic methods to find and solve a system of equations that represented the same information in a different form. (Students could use the equations that they get in Part II to determine the accuracy of their estimates from the graph.)

INCLUDED IN THE STUDENT MANUAL

Task #12 (contd.): Part III Silver Dollars

Yousef likes to buy and sell coins at the flea market on weekends. He is especially interested in Susan B. Anthony silver dollars. By his own trial-and-error experiences and by information gained from other traders, Yousef has found the following data:

Selling Price	Number in Supply	Number in Demand
\$1.40	10	90
\$2.00	19	50
\$3.00	42	25
\$4.20	94	20

1. On graph paper, graph the price-supply points.
2. On the same graph, graph the price-demand points.
3. Use the graph to estimate the price in equilibrium.
4. Sketch a line that comes close to containing the price-supply points.
5. Sketch a line that comes close to containing the price-demand points.
6. What are the coordinates of the point where these two lines intersect?
How does this answer compare with your answer in question 3?

Evaluate Understanding

Have students work individually on the pre-assessment task found on page S-1: (<http://map.mathshell.org/materials/download.php?fileid=1241>) and restated below which will be the introduction to the Shell Center formative assessment lesson Boomerangs.

INCLUDED IN THE STUDENT MANUAL

Task #13: Boomerangs

Phil and Cath make and sell boomerangs for a school event. The money they raise will go to charity.

They plan to make them in two sizes—small and large.

- Phil will carve them from wood. The small boomerang takes two hours to carve and the large one takes three hours to carve. Phil has a total of 24 hours available for carving.
- Cath will decorate them. She only has time to decorate 10 boomerangs of either size.
- The small boomerang will make \$8 for charity. The large boomerang will make \$10 for charity.

They want to make as much money for charity as they can. How many small and large boomerangs should they make? How much money will they then make?

The teacher can visit the “common issues” and “suggested questions and prompts” sections of the Boomerangs lesson found on page T-3: (<http://map.mathshell.org/materials/download.php?fileid=1241>) and also included in the next lesson that serve as teacher resources for analyzing student work.

Closing Activity

Teacher choice Exit Slip: Ask a question of students allowing them to respond with areas in the lesson they are comfortable with, concerned about, etc.

Linear Systems of Equations

Lesson 4 of 6

Problem Solving Lesson: Optimization Problems: Boomerangs

Description:

The purpose of this task is to give students practice writing a constraint equation for a given context. This includes student understanding of the notion of a constraint equation as an equation governing the possible values of the variables in question.

Georgia Standards of Excellence Addressed:

- MGSE9-12.A.CED.2: Create linear, quadratic, and exponential equations in two or more variables to represent relationships between quantities; graph equations on coordinate axes with labels and scales. (The phrase “in two or more variables” refers to formulas like the compound interest formula, in which $A = P(1 + r/n)^{nt}$ has multiple variables.)
- MGSE9-12.A.REI.12: Graph the solution set to a linear inequality in two variables.

Standard(s) for Mathematical Practice Emphasized:

- SMP 1: Make sense of problems and persevere in solving them.
- SMP 2: Reason abstractly and quantitatively.
- SMP 3: Construct viable arguments and critique the reasoning of others.
- SMP 4: Model with mathematics.

The following *Formative Assessment Lesson* is a classroom-ready lesson included to help teachers assess and improve students' understanding of mathematical concepts and skills and their ability to use the "mathematical practices" described in the College Readiness Standards. Research has shown that formative assessment, as embodied in the following lesson, is a powerful way to improve student learning and performance. This approach first allows students to demonstrate their prior understandings and abilities in employing the mathematical processes, and then resolve their own difficulties and misconceptions through structured discussion. This results in more secure long-term learning, reducing the need for re-teaching that otherwise takes so much classroom time. Many often ask, why don't students just remember the procedures they have been taught and practiced? The fact is, that approach works fine in the short term but, as every teacher knows, if procedural knowledge is not underpinned by conceptual understanding, students will quickly forget "how to do it." Read more about the *Formative Assessment Lesson* rationale, structure, and philosophy using the *Brief Guide for Teachers and Administrators* that can be found at <http://map.mathshell.org/materials/index.php>.

PROBLEM SOLVING

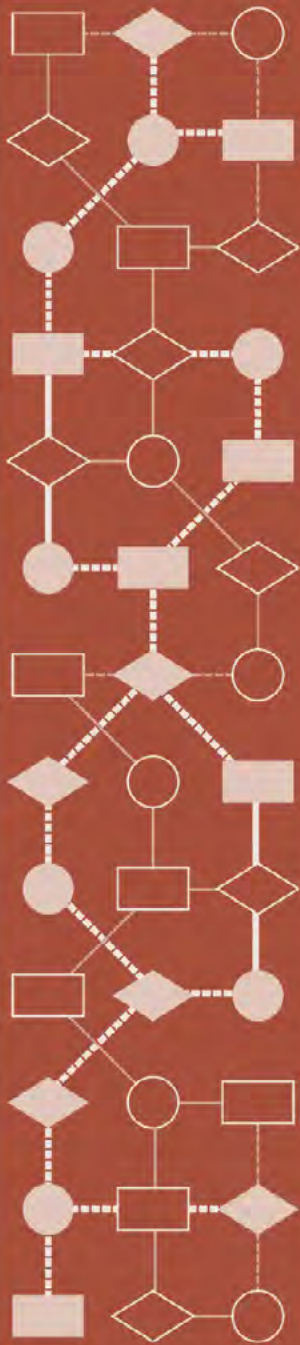

Mathematics Assessment Project
CLASSROOM CHALLENGES
A Formative Assessment Lesson

Optimization Problems: *Boomerangs*

Mathematics Assessment Resource Service
University of Nottingham & UC Berkeley
Beta Version

For more details, visit: <http://map.mathshell.org>
© 2012 MARS, Shell Center, University of Nottingham
May be reproduced, unmodified, for non-commercial purposes under the Creative Commons license
detailed at <http://creativecommons.org/licenses/by-nc-nd/3.0/> - all other rights reserved

BEFORE THE LESSON

Assessment task: *Boomerangs* (15 minutes)

Have the students do this task in class or for homework, a day or more before the formative assessment lesson. This will give you an opportunity to assess the work and to find out the kinds of difficulties students have with it. Then you will be able to target your help more effectively in the follow-up lesson.

Give out the task *Boomerangs*. Introduce the task briefly to help the class to understand the problem and its context. You could show examples of boomerangs.

Boomerangs come from Australia where they are used as weapons or for sport.

When thrown, they travel in a roughly elliptical path and return to the thrower.

Boomerangs are made in many different sizes.

Read through the questions and try to answer them as carefully as you can. Show all your work so that I can understand your reasoning.

As well as trying to solve the problem, I want you to see if you can present your work in an organized and clear manner.

Boomerangs

Phil and Cath make and sell boomerangs for a school event. The money they raise will go to charity. They plan to make them in two sizes: small and large.

Phil will carve them from wood. The small boomerang takes 2 hours to carve and the large one takes 3 hours to carve. Phil has a total of 24 hours available for carving.

Cath will decorate them. She only has time to decorate 10 boomerangs of either size. The small boomerang will make \$5 for charity. The large boomerang will make \$10 for charity.

They want to make as much money for charity as they can. How many small and large boomerangs should they make? How much money will they then make?



It is important that, as far as possible, students are allowed to answer the questions without assistance.

Students who sit together often produce similar answers and then when they come to compare their work, they have little to discuss. For this reason, we suggest that when students do the task individually, you ask them to move to different seats. Then at the beginning of the formative assessment lesson, allow them to return to their usual seats. Experience has shown that this produces more profitable discussions.

Assessing students' responses

Collect students' responses to the task. Make some notes on what their work reveals about their current levels of understanding, and their different problem solving approaches. The purpose of doing this is to forewarn you of issues that will arise during the lesson itself so that you may prepare carefully.

We suggest that you do not score students' work. The research shows that this will be counterproductive as it will encourage students to compare their scores and distract their attention from what they can do to improve their mathematics.

Instead, help students to make further progress by summarizing their difficulties as a series of questions. Some suggestions for these are given on the next page. These have been drawn from common difficulties observed in trials of this lesson unit.

We suggest that you write a list of your own questions, based on your students' work, using the ideas below. You may choose to write questions on each student's work. If you do not have time to do this, just select a few questions that will be of help to the majority of students. These can be written on the board at the beginning of the lesson. If students have used graphs or simultaneous equations in their solutions, add the relevant questions to their work. You may also want to note students with a particular issue, so that you can ask them about their difficulties in the formative lesson.

Common issues:	Suggested questions and prompts:
<p>Student has difficulty getting started</p>	<ul style="list-style-type: none"> • What do you know? • What do you need to find out?
<p>Student makes an incorrect interpretation of the constraints and variables</p> <p>For example: The student has applied just one constraint, such as “Phil has only 24 hrs to make the boomerangs” or “Cath can only make 10 boomerangs.”</p> <p>Or: The student has calculated the profit for making just one type of boomerang.</p>	<ul style="list-style-type: none"> • What figures in the task are fixed? • What can you vary? • What is the greatest number of small/large boomerangs they can make? • Have you used any unnecessary restrictions on the number of small and large boomerangs to be made? • Why can't they make 50 boomerangs?
<p>Student works unsystematically</p> <p>For example: The student shows three or four seemingly unconnected combinations, such as 5 small and 5 large boomerangs, then 10 large.</p>	<ul style="list-style-type: none"> • Can you organize the numbers of large and small boomerangs made in a systematic way? • What would be sensible values to try? Why? • How can you check that you remember all the constraints? • Do you cover all possible combinations? If not, why not? • How do you know for sure your answer is the best option? • Can you organize your work in a table?
<p>Student presents work poorly</p> <p>For example: The student presents the work as a series of unexplained numbers and/or calculations, or as a table without headings.</p> <p>Or: The student circles numbers and it is left to the reader to work out why this is the answer as opposed to any other combination.</p>	<ul style="list-style-type: none"> • Would someone unfamiliar with your type of solution easily understand your work? • Have you explained how you arrived at your answer?
<p>Student has technical difficulties when using graphs</p> <p>For example: Lines are plotted inaccurately, axes are not labeled or the purpose of the graph is not explained.</p> <p>Student has technical difficulties when using simultaneous equations</p> <p>For example: A mistake is made when solving two correct simultaneous equations, or the correct solutions are obtained but the profit is not calculated.</p>	<ul style="list-style-type: none"> • Would someone unfamiliar with your type of solution easily understand your work? • How can you check your answer? • How do your answers help you solve the problem?
<p>Student produces a correct solution</p> <p>Student needs an extension task.</p>	<ul style="list-style-type: none"> • Can you now use a different method? For example, a table or graph, or algebra? • Is this method better than your original one? Why? • In the problem investigated, how many boomerangs can be made in a month rather than 24 hours; would any method(s) be preferable to others?

SUGGESTED LESSON OUTLINE

Improve individual solutions to the assessment task (10 minutes)

Return the assessment task papers to the students, and hand out calculators.

If you have not added questions to individual pieces of work, then write your list of questions on the board (excluding the ones for graphs and simultaneous equations). Students are to select questions appropriate to their own work, and spend a few minutes answering them.

Recall what we were looking at in a previous lesson. What was the task?

I have read your solutions and have some questions about your work.

I would like you to work on your own to answer my questions for about ten minutes.

Collaborative small-group work (10 minutes)

Organize the class into small groups of two or three students, and give out a fresh piece of paper to each group. Ask students to try the task again, this time combining their ideas.

Put your own work aside until later in the lesson. I want you to work in groups now.

Your task is to produce a solution that is better than your individual solutions.

While students work in small groups you have two tasks: to note different student approaches to the task and to support student problem solving.

Note different student approaches to the task

You can then use this information to focus a whole-class discussion towards the end of the lesson. In particular, note any common mistakes. For example, are students consistently using all the constraints, or are they imposing unnecessary constraints? Also note whether students are using algebra and, if so, how they are using it.

Support student problem solving

Try not to make suggestions that move students towards a particular approach to this task. Instead, ask questions that help students to clarify their thinking. You may discover that some students experience some difficulty in keeping more than one constraint at a time in mind. In that case, you may ask them to consider these three questions:

If they were to make only small boomerangs, how much money would they make?

If they were to make two small boomerangs, how many large ones could they also make? How much money would they make?

For the first question, Cath's time is the limiting constraint, whereas in the second question, Phil's time is more significant. Students who organize their work into a table may choose to use column headings for 'Time needed for Phil' and 'Time needed for Cath' which they can use to check that both constraints have been met.

To help students really struggling with the task, use the questions on the previous page to support your own questioning. In particular, if students find it difficult to get started, these questions may be useful:

Try some examples. What happens if they make three small and one large boomerang?

What would be sensible values to try? Why?

Can you organize the numbers of large and small boomerangs made in a systematic way?

If the whole class is struggling on the same issue, write relevant questions on the board. You could also ask students who performed well on the assessment to help struggling students. If students are having difficulty making any progress at all, you could hand out two pieces of sample work to model problem solving methods.

Collaborative analysis of Sample Responses to Discuss (20 minutes)

After students have had sufficient time to attempt the problem, give each group of students a copy of each of the four *Sample Responses to Discuss*, and ask for written comments. This task gives students the opportunity to evaluate a variety of possible approaches to the task, without providing a complete solution strategy.

Imagine you are the teacher and have to assess this work. Correct the work, and write comments on the accuracy and organization of each response.

Each of the sample responses poses specific questions for students to answer. In addition to these, you could ask students to evaluate and compare responses. To help them do more than check to see if the answer is correct, you may wish to use the projector resource *Evaluating Sample Responses to Discuss*:

What do you like about the work?

How has each student organized the work?

What mistakes have been made?

What isn't clear?

What questions would you like to ask this student?

In what ways might the work be improved?

You may decide there is not enough time for each group to work through all four pieces of work. In that case, be selective about what you hand out. For example, groups that have successfully completed the task using one method will benefit from looking at different approaches. Other groups that have struggled with a particular approach may benefit from seeing a student version of the same strategy.

During the small-group work, support the students as before. Note similarities and differences between the sample approaches, and those approaches students took in the small-group work. Also check to see which methods students have difficulties in understanding. This information can help you focus the next activity, a whole-class discussion.

Whole-class discussion: comparing different approaches (10 minutes)

Organize a whole-class discussion to consider the different approaches used in the sample work. Focus the discussion on those parts of the small-group tasks that students found difficult. Ask the students to compare the different solution methods.

Which approach did you like best? Why?

Which approach did you find most difficult to understand?

To critique the different strategies use the questions on the slide *Evaluating Sample Responses to Discuss* and the worksheets *Sample Responses to Discuss*.

Alex has realized that you have to take account of both constraints: Phil's time for making the boomerangs and Cath's time for decorating them. Alex has not examined different combinations of cases.

Phil can only make 12 small or 8 large boomerangs in 24 hours
 12 small makes \$96
 8 large makes \$80
 Cath only has time to make 10, so \$96 is impossible.
 She could make 10 small boomerangs which will make \$80.
 So she either makes 8 large or 10 small boomerangs and makes \$80.

Danny has found an effective way to organize his work, using a table. He has made some mistakes in this table, however. Part of the problem is that he loses track of the two constraints. It might have been helpful for him to include two additional columns headed: 'Time needed (≤ 24 hours)' and 'Total number made (≤ 10).'
 Then he could test each case and put a check mark if it satisfies both constraints.

No of Small s	$s \times 8$	No of large L	$L \times 10$	Profit
0	0	8	80	80
1	8	7	70	78
2	16	6	60	76
3	24	5	50	74
4	32	5	50	82 ←
5	40	4	40	80
6	48	3	30	78

The most Profit is \$82

Jeremiah has tried an algebraic approach and has hit upon the correct solution. However, he has used equalities rather than inequalities. He needs to calculate the total profit to complete the question.

Small boomerangs = x
 Large boomerangs = y
 Time to carve $2x + 3y = 24$ ①
 Only 10 can be decorated $x + y = 10$ ②
 $2x + 2y = 20$ ③
 $① - ③ \quad y = 4 \quad x = 6$
 So make 4 large boomerangs
 6 small boomerangs.

Tanya has used a graphical approach, but her graph of $2x + 3y = 24$ is inaccurate and should be redrawn. This graph is powerful in that it shows the entire feasible solution space—the integer points on the grid. She has not explained why her method will give the greatest profit.

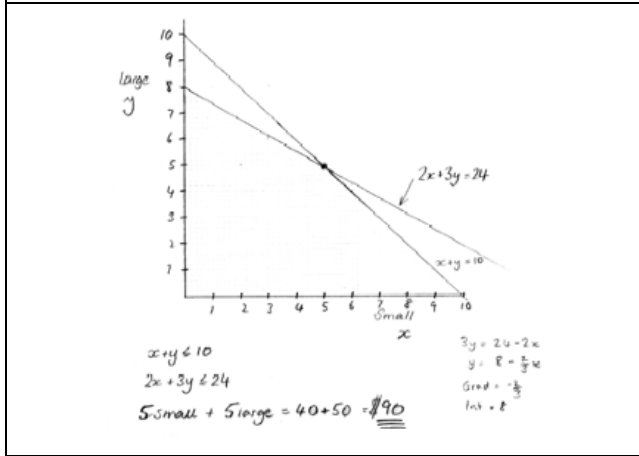

Review individual solutions to the assessment task (10 minutes)

Ask students to read through their original responses to the task.

Read through your original solution and think about your work this lesson.

Write down what you have learned during the lesson.

Which method would you prefer to use if you were doing the task again? Why?

Encourage students to compare the new approaches they met during the lesson with their original method.

Some teachers set this task as homework.

SOLUTIONS

If one assumes that ten boomerangs are made, then the following table of possibilities may be made.

The constraint on carving hours is broken when more than four large boomerangs are made.

Number of small	Number of large	Total number (≤ 10)	Carving hours (≤ 24)	Profit made
10	0	10	20	80
9	1	10	21	82
8	2	10	22	84
7	3	10	23	86
6	4	10	24	88
5	5	10	25	90

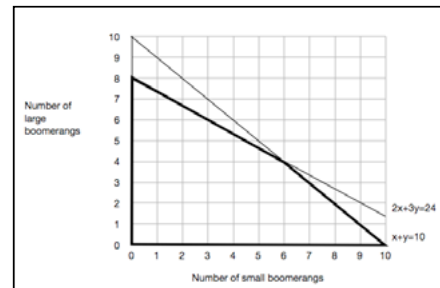

This approach, however, does not include the possibility of making fewer than ten boomerangs. A more complete approach would be to draw a graph showing all possibilities.

The possible combinations to be checked are the integer points within the bold region on the graph. The maximum profit occurs, however, when six small and four large boomerangs are made. This profit is \$88.

(This can be seen graphically by drawing lines of constant profit on the graph, e.g. $8x + 10y = 80$. This idea may emerge in discussion.)

Boomerangs

Phil and Cath make and sell boomerangs for a school event.
The money they raise will go to charity.

They plan to make them in two sizes: small and large.

Phil will carve them from wood.

The small boomerang takes 2 hours to carve and the large one takes 3 hours to carve.

Phil has a total of 24 hours available for carving.

Cath will decorate them.

She only has time to decorate 10 boomerangs of either size.

The small boomerang will make \$8 for charity.

The large boomerang will make \$10 for charity.

They want to make as much money for charity as they can.

How many small and large boomerangs should they make?

How much money will they then make?



Sample Responses to Discuss: Alex

Phil can only make 12 small or 8 large boomerangs in 24 hours
12 small makes \$96
8 large makes \$80
Cath only has time to make 10, so \$96 is impossible.
She could make 10 small boomerangs which will make \$80.
So she either makes 8 large or 10 small boomerangs
and makes \$80.

What assumptions has Alex made?

.....
.....

Are these assumptions correct? Explain your answer.

.....
.....

General comments:

.....
.....
.....
.....
.....
.....
.....

Sample Responses to Discuss: Danny

No of small s	$s \times 8$	No of large	$l \times 10$	Profit
0	0	8	80	80
1	8	7	70	78
2	16	6	60	76
3	24	5	50	74
4	32	5	50	82 ←
5	40	4	40	80
6	48	3	30	78

The most Profit is \$82

Why do you think Danny starts with 0 small and 8 large boomerangs and stops at 6 small and 3 large boomerangs?

.....

What piece of information has Danny forgotten to use?

.....

General comments:

.....

Sample Responses to Discuss: Jeremiah

Small boomerangs = x
Large boomerangs = y
Time to carve $2x + 3y = 24$ ①
Only 10 can be decorated $x + y = 10$ ②
 $2x + 2y = 20$ ③

①-③ $y = 4$ $x = 6$

So make 4 large boomerangs
6 small boomerangs.

Is it correct to use the equals sign in equations 1, 2 and 3? Explain your answer?

.....
.....

Why is Jeremiah's solution incomplete?

.....
.....

General comments:

.....
.....
.....
.....
.....
.....
.....

Sample Responses to Discuss: Tanya

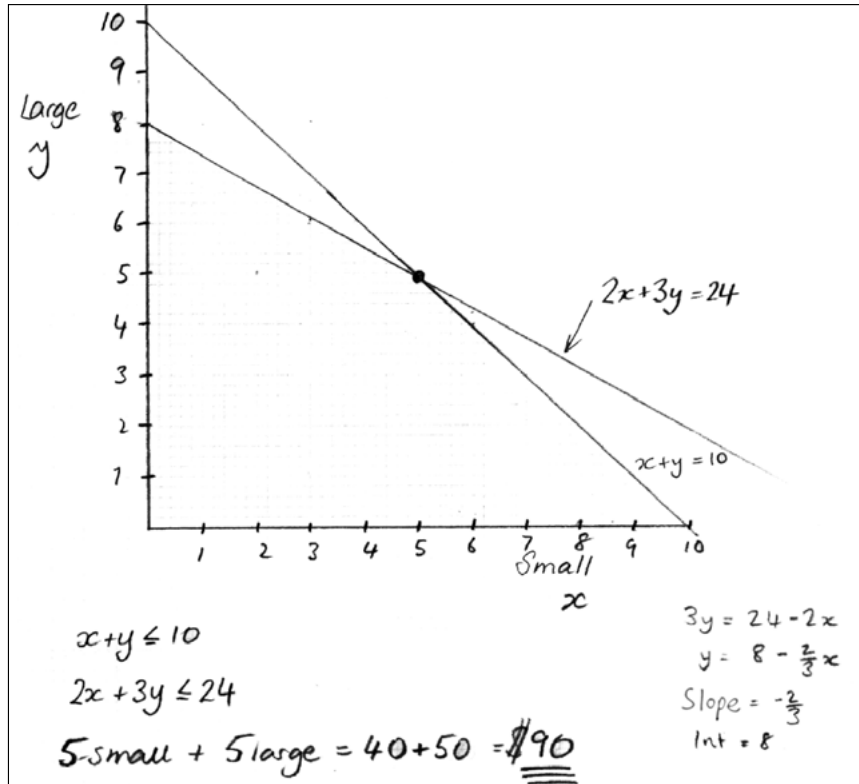

What is the purpose of the graph?

.....

.....

What is the point of figuring out the slope and intercept?

.....

.....

General comments:

.....

.....

.....

Evaluating *Sample Responses to Discuss*

- **What do you like about the work?**
- **How has each student organized the work?**
- **What mistakes have been made?**
- **What isn't clear?**
- **What questions do you want to ask this student?**
- **In what ways might the work be improved?**

Alex's solution

Phil can only make 12 small or 8 large boomerangs in 24 hours

12 small makes \$96

8 large makes \$80

Cath only has time to make 10, so \$96 is impossible.

She could make 10 small boomerangs which will make \$80.

So she either makes 8 large or 10 small boomerangs
and makes \$80.

Danny's solution

No of small s	$s \times 8$	No of large	$l \times 10$	Profit
0	0	8	80	80
1	8	7	70	78
2	16	6	60	76
3	24	5	50	74
4	32	5	50	82 ←
5	40	4	40	80
6	48	3	30	78

The most Profit is \$82

Jeremiah's solution

Small boomerangs = x

Large boomerangs = y

Time to carve $2x + 3y = 24$ ①

Only 10 can be decorated $x + y = 10$ ②

$$2x + 2y = 20 \quad \text{③}$$

$$\text{①} - \text{③} \quad y = 4 \quad x = 6$$

So make 4 large boomerangs

6 small boomerangs.

Tanya's solution

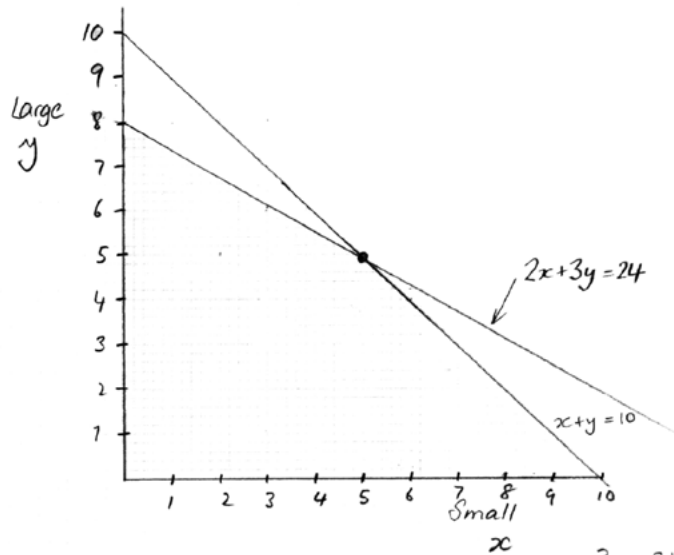

$$x + y \leq 10$$
$$2x + 3y \leq 24$$

$$5\text{-small} + 5\text{large} = 40 + 50 = \underline{\underline{\$90}}$$

$$3y = 24 - 2x$$
$$y = 8 - \frac{2}{3}x$$

Slope = $-\frac{2}{3}$
Int = 8

Mathematics Assessment Project
CLASSROOM CHALLENGES

This lesson was designed and developed by the
Shell Center Team
at the
University of Nottingham
Malcolm Swan, Nichola Clarke, Clare Dawson, Sheila Evans
with
Hugh Burkhardt, Rita Crust, Andy Noyes, and Daniel Pead

It was refined on the basis of reports from teams of observers led by
David Foster, Mary Bouck, and Diane Schaefer
based on their observation of trials in US classrooms
along with comments from teachers and other users.

This project was conceived and directed for
MARS: Mathematics Assessment Resource Service
by
Alan Schoenfeld, Hugh Burkhardt, Daniel Pead, and Malcolm Swan
and based at the University of California, Berkeley

We are grateful to the many teachers, in the UK and the US, who trialed earlier versions
of these materials in their classrooms, to their students, and to
Judith Mills, Carol Hill, and Alvaro Villanueva who contributed to the design.

This development would not have been possible without the support of
Bill & Melinda Gates Foundation
We are particularly grateful to
Carina Wong, Melissa Chabran, and Jamie McKee

© 2012 MARS, Shell Center, University of Nottingham
This material may be reproduced and distributed, without modification, for non-commercial purposes,
under the Creative Commons License detailed at <http://creativecommons.org/licenses/by-nc-nd/3.0/>
All other rights reserved.
Please contact map.info@mathshell.org if this license does not meet your needs.

Practice Together / in Small Groups / Individually

INCLUDED IN THE STUDENT MANUAL

Task #14: Writing Constraints

In (a)–(d), (i) write a constraint equation, (ii) determine two solutions, and (iii) graph the equation and mark your solutions.

- The relation between quantity of chicken and quantity of steak if chicken costs \$1.29/lb and steak costs \$3.49/lb and you have \$100 to spend on a barbecue.
- The relation between the time spent walking and driving if you walk at 3 mph then hitch a ride in a car traveling at 75 mph, covering a total distance of 60 miles.
- The relation between the volume of titanium and iron in a bicycle weighing 5 kg, if titanium has a density of 4.5g/cm³ and iron has a density of 7.87 g/cm³ (ignore other materials).
- The relation between the time spent walking and the time spent canoeing on a 30 mile trip if you walk at 4 mph and canoe at 7 mph.

(<http://www.illustrativemathematics.org/illustrations/610>)

Commentary for the Teacher:

The purpose of this task is to give students practice writing a constraint equation for a given context. Instruction accompanying this task should introduce the notion of a constraint equation as an equation governing the possible values of the variables in question (i.e., “constraining” said values). In particular, it is worth differentiating the role of constraint equations from more functional equations, (e.g., formulas to convert from degrees Celsius to degree Fahrenheit.) The task has students interpret the context and choose variables to represent the quantities, which are governed by the constraint equation and the fact that they are non-negative (allowing us to restrict the graphs to points in the first quadrant only).

The four parts are independent and can be used as separate tasks.

Possible Solution:

- a) i. Let c be the number of pounds of chicken you buy and s the number of pounds of steak. Then $1.29c + 3.49s = 100$.
- ii. Many combinations are reasonable. For example, you could buy 10 pounds of chicken, so that $c = 10$. This gives

$$1.29 \times 10 + 3.49s = 100$$
$$s = (100 - 12.9) / 3.49 = 24.957 \approx 25.0$$

So you would buy approximately 25 lb of steak. Thus (10,25) is one reasonable solution. Alternatively, you could buy 25 lb of chicken, so that $c=25$, and compute:

$$1.29 \times 25 + 3.49s = 100$$
$$s = (100 - 1.29 \times 25) / 3.49 = 19.412 \approx 19.4$$

So you would buy about 19.4 lb of steak. Thus (25,19.4) is another reasonable solution.

lii.

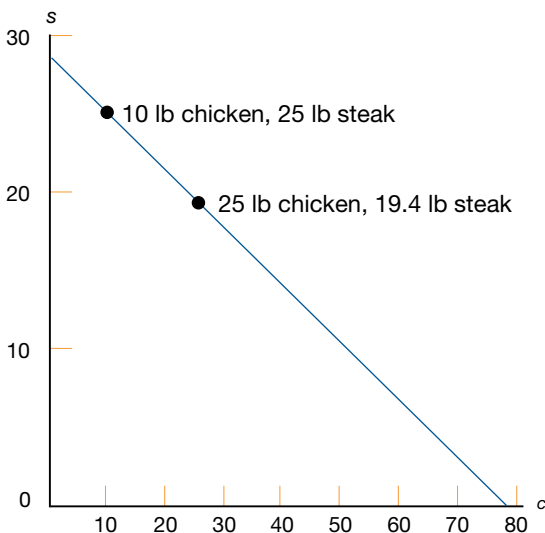

- b) i. If you walk for w hours and drive for d hours, then $3w + 75d = 60$.
 ii. If you walk for two hours, then $w = 2$, so

$$3 \times 2 + 75d$$

$$d = 60 (60 - 6) / 75 = 0.72$$

If you ride for 0.72 hours, or $0.72 \times 60 = 43$ minutes. Therefore, $(2, 0.72)$ is one reasonable solution. If you walk for five hours, then $w = 5$, so

$$3 \times 5 + 75d$$

$$d = 60 (60 - 15) / 75 = 0.6$$

If you ride for 0.6 hours, or $0.6 \times 60 = 36$ minutes. So, another reasonable solution is $(5, 0.6)$.

lii.

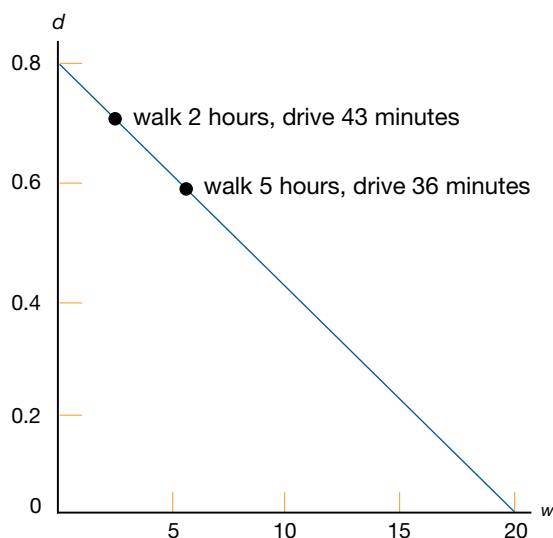

- c) i. If t is the volume of titanium and i is the volume of iron (in cm^3), then $4.5t + 7.87i = 5000$. Note that the density is given in grams and the total weight of the bicycle is given in kg, so we must convert 5 kg to 5000 g.

ii. If you use 600 cm^3 of titanium, then $t = 600$, and

$$4.5 \times 600 + 7.87i = 5000$$

$$i = (5000 - 4.5 \times 600) / 7.87 = 292.25$$

you would use about 292 cm^3 of iron. Therefore, a possible solution is $(600, 292)$.

Or you could use 350 cm^3 of titanium, so

$$4.5 \times 350 + 7.87i = 5000$$

$$i = (5000 - 4.5 \times 350) / 7.87 = 435.20$$

you would use about 435 cm^3 of iron. Therefore, a possible solution is $(350, 435)$.

lii.

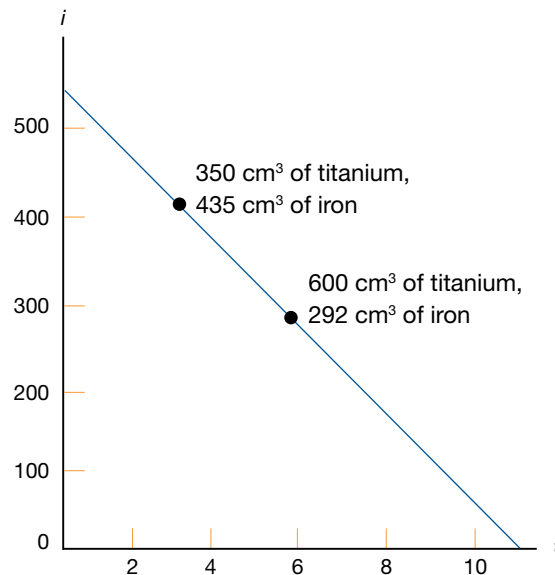

d) i. If w is the time spent walking and c is the time spent canoeing, both in hours, then $4w + 7c = 30$.

ii. If you walk for three hours then $w = 3$, so

$$4 \times 3 + 7c = 30$$

$$c = (30 - 12) / 7 = 2.57$$

Therefore, you canoe for about 2.6 hours. So one possible solution is $(3, 2.6)$. If you walk for one hour, then $w = 1$, so

$$4 \times 1 + 7c = 30$$

$$c = (30 - 4) / 7 = 3.71$$

Therefore, you canoe for about 3.7 hours. So another possible solution is $(1, 3.7)$.

iii.

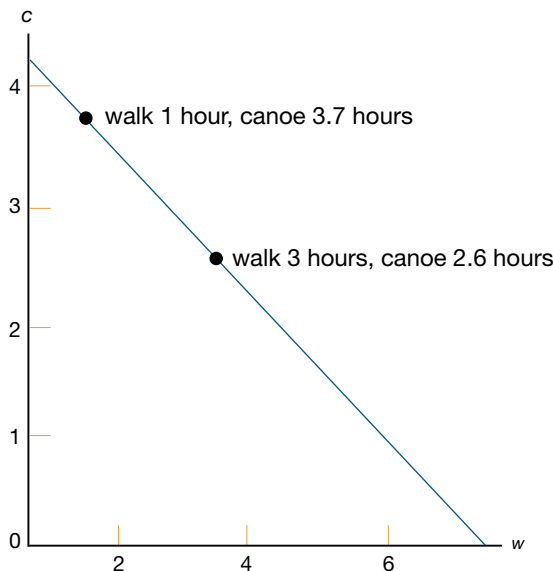

Evaluate Understanding

Have students review their original work on the boomerang question from the previous lesson (page T7).

Closing Activity



Have students work individually or in small groups on the Illustrative Mathematics Fishing Adventure 3 task.

INCLUDED IN THE STUDENT MANUAL

Task #15: Fishing Adventure 3

Fishing Adventures rents small fishing boats to tourists for day-long fishing trips. Each boat can hold at most eight people. Additionally, each boat can only carry 1200 pounds of people and gear for safety reasons. Assume on average an adult weighs 150 pounds and a child weighs 75 pounds. Also, assume each group will require 200 pounds of gear plus 10 pounds of gear per person.

- Write an inequality that illustrates the weight limit for a group of adults and children on the fishing boat and a second inequality that represents the total number of passengers in the fishing boat. Graph the solution set to the inequalities.
- Several groups of people wish to rent a boat. Group 1 has four adults and two children. Group 2 has three adults and five children. Group 3 has eight adults. Which of the groups, if any, can safely rent a boat? What other combinations of adults and children are possible?

(<http://www.illustrativemathematics.org/illustrations/644>)

Commentary *for the Teacher:*

In this task, students write and solve inequalities, and represent the solutions graphically.

This particular task could be used for instruction or assessment. This task also has some elements of modeling with mathematics. To find reasonable estimates for the number of people that can rent a boat given certain restrictions, it is necessary to make some simplifying assumptions. In the case of this task we made assumptions about the average weight of adults and children, but this is only one possibility for solving a similar and more open ended problem.

Instead of renting a boat, the problem could also be set in the context of riding an elevator. Being cramped into an elevator often makes you wonder about weight restrictions.

Possible Solution:

1. Let a = number of adults and c = number of children. Then $150a$ is the total weight contributed by the adults, and $75c$ is the total weight contributed by the children. Since 10 pounds of gear is required per adult and per child, we need to add $10a$ and $10c$ to each of these amounts.

$$150a + 10a = 160a$$

$$75c + 10c = 85c$$

So the total weight in the boat contributed solely by the people is

$$160a + 85c$$

Because each group also requires 200 pounds of gear regardless of how many people there are, we add 200 to the above amount. We also know that the total weight cannot exceed 1200 pounds. So, we arrive at the following inequality:

$$160a + 85c + 200 \leq 1200$$

or

$$160a + 85c \leq 1000$$

To write an inequality for the passenger limit in a boat, we observe that the total number of people aboard is the number of adults, a , added to the number of children, c . Since the number aboard cannot exceed 8, we arrive at

$$a + c \leq 8$$

We now have a system of linear inequalities:

$$160a + 85c \leq 1000$$

$$a + c \leq 8$$

The graph of the two inequalities is shown on the next page. Note that any solution corresponds to a coordinate point (c,a) that lies in the doubly shaded region and where both coordinates are non-negative integers.

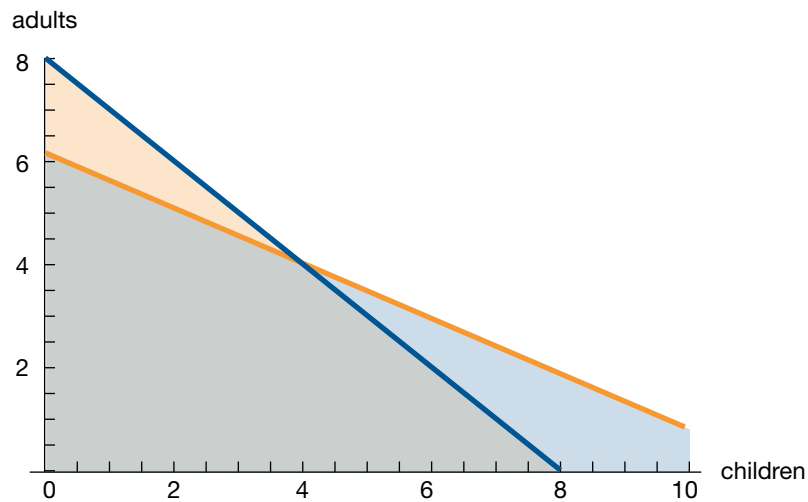

2. We can find out which of the groups, if any, can safely rent a boat by first noting that all groups have less than eight total people, thus the passenger limit inequality is satisfied. Substituting the number of adults and children in each group for a and c in our weight inequality, we see that,

$$\text{For Group 1: } 160(4) + 85(2) + 200 = 1010 \leq 1200$$

$$\text{For Group 2: } 160(3) + 85(5) + 200 = 1105 \leq 1200$$

$$\text{For Group 3: } 160(8) + 200 = 1480 \not\leq 1200$$

We find that both Group 1 and Group 2 can safely rent a boat, but that Group 3 exceeds the weight limit, and so cannot rent a boat.

We could also have done a visual check to see which of the point $(2,4)$, $(5,3)$, and $(0,8)$ lies in the doubly shaded region.

Other combinations of adults and children are possible, and can be found easily by looking at our graph. Any combination where (c,a) lies in the doubly shaded region will work. For example, six children and one adult or one child and five adults.

Linear Systems of Equations

Lesson 5 of 6

Formative Assessment Lesson: Defining Regions Using Inequalities

Description:

This lesson unit is intended to help you assess how well students are able to use linear inequalities to create a set of solutions. In particular, the lesson will help you identify and assist students who have difficulties in:

- Representing a constraint by shading the correct side of the inequality line.
- Understanding how combining inequalities affects a solution space.

Georgia Standards of Excellence Addressed:

- MGSE9-12.A.CED.3: Represent constraints by equations or inequalities, and by systems of equations and/or inequalities, and interpret data points as possible (i.e. a solution) or not possible (i.e. a non-solution) under the established constraints.
- MGSE9-12.A.REI.12: Graph the solution set to a linear inequality in two variables.

Standard(s) for Mathematical Practice Emphasized:

- SMP 4: Model with mathematics.
- SMP 6: Attend to precision.
- SMP 7: Look for and make use of structure.

The following *Formative Assessment Lesson* is a classroom-ready lesson included to help teachers assess and improve students' understanding of mathematical concepts and skills and their ability to use the "mathematical practices" described in the College Readiness Standards. Research has shown that formative assessment, as embodied in the following lesson, is a powerful way to improve student learning and performance. This approach first allows students to demonstrate their prior understandings and abilities in employing the mathematical processes, and then resolve their own difficulties and misconceptions through structured discussion. This results in more secure long-term learning, reducing the need for re-teaching that otherwise takes so much classroom time. Many often ask, why don't students just remember the procedures they have been taught and practiced? The fact is, that approach works fine in the short term but, as every teacher knows, if procedural knowledge is not underpinned by conceptual understanding, students will quickly forget "how to do it." Read more about the *Formative Assessment Lesson* rationale, structure, and philosophy using the *Brief Guide for Teachers and Administrators* that can be found at <http://map.mathshell.org/materials/index.php>.

CONCEPT DEVELOPMENT

Mathematics Assessment Project
CLASSROOM CHALLENGES
A Formative Assessment Lesson

Defining Regions Using Inequalities

Mathematics Assessment Resource Service
University of Nottingham & UC Berkeley
Beta Version

For more details, visit: <http://map.mathshell.org>
© 2012 MARS, Shell Center, University of Nottingham
May be reproduced, unmodified, for non-commercial purposes under the Creative Commons license
detailed at <http://creativecommons.org/licenses/by-nc-nd/3.0/> - all other rights reserved

BEFORE THE LESSON

Assessment task: *Combining Inequalities* (15 minutes)

Set this task, in class or for homework, a few days before the formative assessment lesson. This will give you an opportunity to assess the work, to find out the kinds of difficulties students have with it. You will then be able to target your help more effectively in the follow-up lesson.

Give each student a copy of *Combining Inequalities*, a pencil and a ruler.

Briefly introduce the task:

Spend 15 minutes individually, answering these questions.

Show all your work, so that I can understand your reasoning.

It is important that students answer the questions without your assistance, as far as possible.

Combining Inequalities

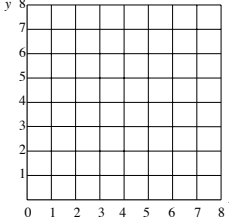

Some treasure has been buried at a point (x,y) on the grid, where x and y are whole numbers. Here are three clues to help you find the treasure:

Clue 1: $x > 2$ **Clue 2:** $x + y < 8$ **Clue 3:** $2y - x \geq 0$

1. Which of the following points could be a possible location for the treasure?
 The points must satisfy *all three* clues.
 Circle the answers you choose.

(3,2) (2,3) (5,3) (3,5) (4,3) (5,2)

2. On the grid show *all* the possible places the treasure could be located.

3. Here are two more clues: **Clue 4:** $y > x - 4$ **Clue 5:** $y < x - 1$
 Which clue doesn't help at all?
 Explain why.

At which point is the treasure located?

Students should not worry too much if they cannot understand or do everything, because in the next lesson they will engage in a similar task, which should help them. Explain to students that by the end of the next lesson, they should expect to answer questions such as these confidently. This is their goal.

Assessing students' responses

Collect students' written work for formative assessment. Read through their papers and make informal notes on what their work reveals about their current levels of understanding.

We strongly suggest that you do not write scores on students' work. Research shows that this is counterproductive, as it encourages students to compare scores, and distracts their attention from what they could do to improve their mathematics.

Instead, help students to make further progress by asking questions that focus their attention on aspects of their work. Some suggestions for these are given on the next page. These have been drawn from common difficulties observed in trials of this unit.

We suggest that you write your own lists of questions, based on your own students' work, using the ideas that follow. You may choose to write questions on each student's work. If you do not have time to do this, select a few questions that will help the majority of students. These can then be written on the board at the end of the lesson.

Common issues:	Suggested questions and prompts:
<p>Student has difficulty distinguishing between $>$ and \geq, or $<$ and \leq For example: The student includes (2,3) and (5,3) as possible locations for the target (Q1.) Or: The student states the treasure is located at (2,1), (4,3), (5,3), or (3,2) (Q3.) Or: The student does not use a dashed line for $<$ or $>$ inequalities (Q2 or Q3.)</p>	<ul style="list-style-type: none"> • Write the inequalities into words. • What is the difference between $>$ and \geq? • What is the difference between $<$ and \leq? • The point (2,5) is outside the region where the treasure is located. Which clue tells you this? • Are points on the line $x = 2$ possible locations for the treasure? Are points on the line $2y - x = 0$ possible locations for the treasure? How can you distinguish graphically between the two? • Which points are not allowed?
<p>Q2. Student uses guess and check to figure out the possible location for the treasure The student does not draw the inequality boundaries as lines on the grid, but instead guesses possible locations for the treasure and checks to see if they fit the clues.</p>	<ul style="list-style-type: none"> • Can you think of a quicker way to figure out the possible locations? • How can you convince me there are no other possible points? • How can you use the graph to show the region where the treasure is located?
<p>Q3. Student provides insufficient reasoning For example: The student does not explain the reason why Clue 4 is unhelpful.</p>	<ul style="list-style-type: none"> • How does the clue affect the region where the treasure is located? • Does this clue help you find the position of the treasure?
<p>Q3. Student assumes the treasure is located at one of the points chosen in Q1</p>	<ul style="list-style-type: none"> • Check to see if your point fits your new clue.
<p>Student correctly answers all the questions The student needs an extension task.</p>	<ul style="list-style-type: none"> • Another treasure is at (6,5). Write just two clues that will locate the exact position of the treasure. Your clues should use the inequality symbols $>$, $<$, \geq, or \leq.

SUGGESTED LESSON OUTLINE

If you have a short lesson, or you find the lesson is progressing at a slower pace than anticipated, we suggest you end the lesson after the paired work, ‘Preparing to play *Give Us a Clue!*’, and continue in a second lesson.

Whole-class interactive introduction: *Hunting the Target* (15 minutes)

Give each student either a mini-whiteboard, pen, and eraser, or a sheet of squared paper.

Use slide P-1 of the projector resources to project the 6×6 coordinate grid on to the board.

Write the pair of coordinates, (2,2) on a piece of paper, fold it in half (hiding the coordinates) and stick this to the board.

I am thinking of a target point on this grid. I have written the coordinates on this paper. Both coordinates are integers.

Your task is to guess which point I am thinking of.

Here is the first clue: $3y + 2x \leq 12$

Does anyone know what this clue means?

Students may need careful leading through this idea, so take this stage slowly. Use questions such as the following, asking students to respond using their mini-whiteboards:

Show me the coordinates of a point that satisfies the clue.

Can you show me another point? ... and another? How do you know?

As students suggest possible points, mark these clearly on the grid.

*Where are all the points that satisfy this clue?
 [On or below the line $3y + 2x = 12$.]*

*Where are all the points that don't satisfy this clue?
 [Above the line $3y + 2x = 12$.]*

*Give me a point that **just** satisfies the clue.*

*Give me a point that **easily** satisfies the clue.*

Explain that for this lesson, the region that does not satisfy a clue is to be shaded out.

To help students keep track of each clue you may want to use a different color marker for each inequality.

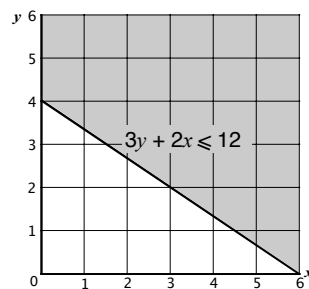
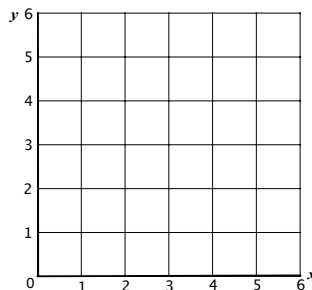

Here's the second clue: $x > 1$

Shade out all the points that are eliminated.

Show me the new region.

Which points are possible now?

Is (1,2) a possible point?

Explain that we use a dashed line to show that the points on the line $x = 1$ are not included as possible points for the target.

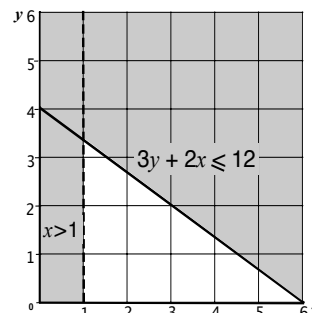

Here's the third clue: $y > x - 1$

Shade out all the points that are eliminated.

Which points are possible now?

Show me the new region.

Do you know the point I am thinking of yet?

Is (2,2) the only possibility?

Why can't (3,2) be a possible point for the target?

Although there are many non-integer points that are possible, explain that for this lesson we will stick with integer coordinates.

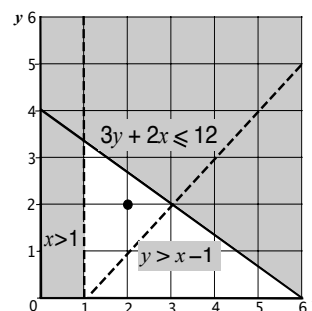

Preparing to play Give Us a Clue! (10 minutes)

Give each student a copy of the sheet *Give Us a Clue!*

Use slide P-2 of the projector resource to project the 8×8 coordinate grid onto the board.

You are soon going to play a game called 'Give Us a Clue!'

You will use the lines on the small graphs on the handout.

Before beginning the game you need to figure out the inequalities for the regions to the left and right of each given line. You will use these inequalities as clues in the game.

For example, look at the line $2x - y = 8$.

Which side of the line are points that fit the inequality $2x - y \geq 8$?

Which side of the line are points that fit the inequality $2x - y \leq 8$?

In order to answer these two questions, it is helpful to test the inequality with specific pairs of coordinates. These are sometimes called test points.

(0,0) is usually a good choice for a test point, since it makes the arithmetic easy, but if the line itself goes through the origin, then another point should be chosen:

Can you put the inequality into words?

Let's use the origin (0,0) as a test point. This point is to the left of the line.

Which of the two inequalities [$2x - y \geq 8$ or $2x - y \leq 8$] does it fit?

Now choose your own test point to the right of the line. Use its coordinates to check the inequality for this region.

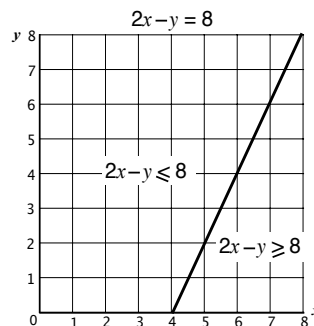

Since $2(0) - 0 \leq 8$ is true, the origin is included in the region $2x - y \leq 8$. This region is to the left of the line.

Paired work: preparing to play Give Us a Clue! (10 minutes)

Organize the class into pairs of students.

Explain how students should work collaboratively.

Take it in turns to figure out the inequalities for each region of the twelve small graphs.

Once you have done this, explain to your partner how you came to your decision.

Your partner should either explain that reasoning again in his or her own words, or challenge the reasons you gave.

*You need to agree on, and **both** be able to explain, the inequalities for each region of each graph.*

Make sure you write all the inequalities on your own copy of Give Us a Clue!

There is no need to shade the graphs.

The purpose of this structured paired work is to make each student engage with their partner's explanations, and to take responsibility for their partner's understanding.

You have two tasks during the paired work: to note aspects of the task students find difficult, and support student reasoning.

Note aspects of the task students find difficult

For example, are students having difficulties using a test point? Do they understand the difference between inequality symbols? You can use information about particular difficulties to focus a whole-class discussion towards the end of the lesson.

Support student reasoning

Try not to make suggestions that move students towards a particular answer. Instead, ask questions to help students to reason together. For students struggling to understand the symbols, it may help if they put the inequalities into words.

How did you figure out the inequality for this region?

[Select a graph that goes through the origin.] Why is (0,0) not a good test point for this graph?

[Select one of the first four graphs.] Why is (4,4) not a good test point to use for this graph?

Sharing work: Preparing to play Give Us a Clue! (10 minutes)

Ask students to check their work with a neighboring pair of students.

Check to see which graphs are different.

When there is a disagreement, take turns to justify your decision. If you still don't agree, ask for further explanation.

Both of you need to agree and understand the math.

Students playing Give Us a Clue! (15 minutes)

When students are satisfied with their twelve graphs, use slide P-3 of the projector resource to introduce the game:

In your pairs, you are now going to play 'Give Us a Clue!'

One of you will be the target picker, and the other the target hunter.

The target picker decides on the position of the target, and gives the clues.

When giving clues, the target picker can use any inequality sign (\leq , $<$, \geq , $>$), but not the '=' sign. Try to give helpful clues! As you give the clues, write them as a list on your mini-whiteboard.

The target hunter uses the clues to find the target.

The aim of the game for both partners is to find the target in the least number of tries.

Both partners should use a blank grid, to keep track of the clues that are given.

Each time a clue is given, shade out the region where the target cannot be located.

It is important that students cannot see each other's graphs. They could use a book or folder to hide the graph from their partner.

Encourage students to give clues using the correct inequality language, rather than using imprecise language such as "The point is above the line."

When the target picker has used all the useful inequalities on the handout, they could make up their own.

At the end of each game, students should check each other's graphs. If they are not the same, encourage them to work together to identify mistakes made. The mini-whiteboard listing the clues may help sort out disagreements. This should be seen as a collaborative rather than competitive activity.

Then students can reverse roles.

For students who have successfully completed this task, ask them to create their own inequalities, and use them to play the game with their partner.

Whole-class discussion (10 minutes)

In the summary discussion you can explore the best strategy for giving a clue, while revising the main math concepts in the lesson. Students should use their mini-whiteboards to respond to your questions.

Use slide P-2 of the projector resource to project the 8×8 coordinate grid on to the board.

We will now investigate how to give the best clues for targets within an 8×8 grid. We are still using the inequalities on the work sheet.

*Can anyone think of the best first clue for the point $(2,5)$?
[$y > 2x$.]*

Ask a few students to justify their answers. Use different color markers to draw their clues on the board.

*In this case, is the clue $y \geq 2x$ better than the clue $y > 2x$?
Why?*

Once students are satisfied that they are using the best first clue ask:

What is the next best clue? [$y < x + 4$.]

Again ask students to explain their reasoning.

How do you know $y < x + 4$ is a better clue than $y < x$? Show me.

If students are struggling with the difference between a clue that uses $<$ and one that uses \leq ask:

How many points could the target be if you use the clue $y < x + 4$?

How many points could the target be if you use the clue $y \leq x + 4$?

Now ask for a final clue:

And what is another good clue? [$y > 4$]

How many places could the target be now?

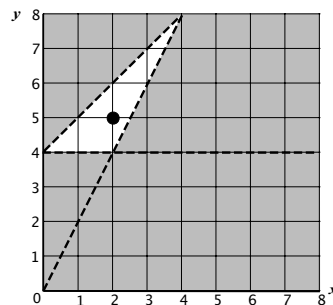
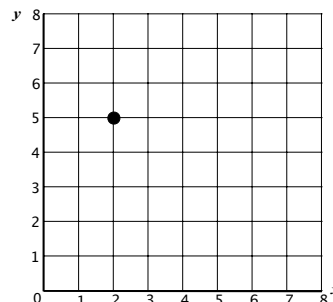

You could extend this further by asking:

Can you think of a target point within the 8×8 grid that only requires two clues?

It will be a point on a line. For example, when the target point is $(8,4)$, the clues could be $y \leq 4$ and $x + 2y \geq 16$.

Improving individual solutions to the assessment task (10 minutes)

Return their original assessment *Combining Inequalities* to the students, as well as a second blank copy of the task.

Look at your original responses and think about what you have learned this lesson.

Using what you have learned, try to improve your work.

If you have not added questions to individual pieces of work, write your list of questions on the board. Students should select from this list only the questions they think are appropriate to their own work.

Explain to students that Questions 1 and 2 are concerned with just the first three clues. When answering these questions they should ignore Clues 4 and 5.

If you find you are running out of time, then you could set this task in the next lesson, or for homework.

SOLUTIONS

Assessment task: Combining Inequalities

- The points (3,2) and (4,3) are the points that satisfy all clues.
- The possible places for the target are indicated by the bold dots on the grid below:

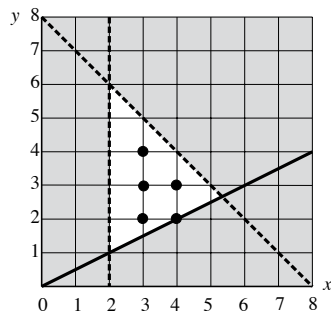

- Clue 4 is unhelpful because it doesn't add any extra information.
This is because the region $y > x - 4$ includes all of the above region.
Clue 5 excludes all solutions but (4,2) so this is where the treasure is located. (See diagram)

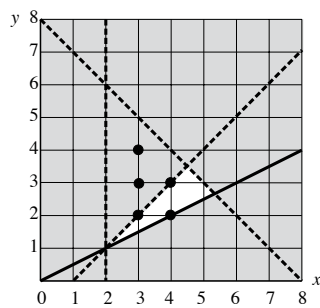

Combining Inequalities

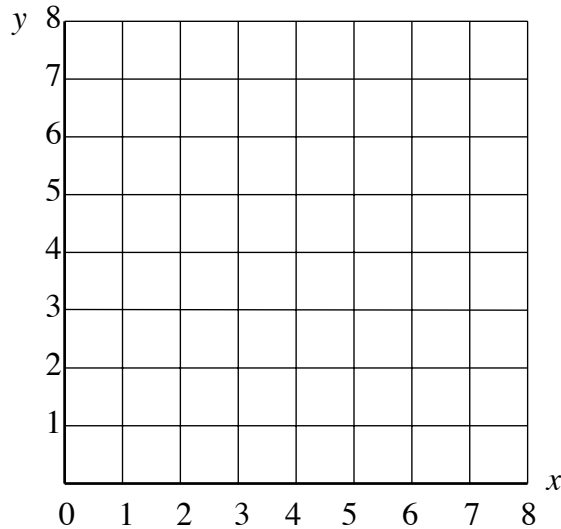

Some treasure has been buried at a point (x,y) on the grid, where x and y are whole numbers.

Here are three clues to help you find the treasure:

Clue 1: $x > 2$

Clue 2: $x + y < 8$

Clue 3: $2y - x \geq 0$

1. Which of the following points could be a possible location for the treasure?

The points must satisfy *all three* clues.

Circle the answers you choose.

- (3,2) (2,3) (5,3) (3, 5) (4,3) (5, 2)

2. On the grid show *all* the possible places the treasure could be located.

3. Here are two more clues: **Clue 4:** $y > x - 4$

Clue 5: $y < x - 1$

Which clue doesn't help at all?

Explain why.

.....

At which point is the treasure located?

.....

Give Us a Clue!

Use these grids to record the clues given by the teacher or your partner.

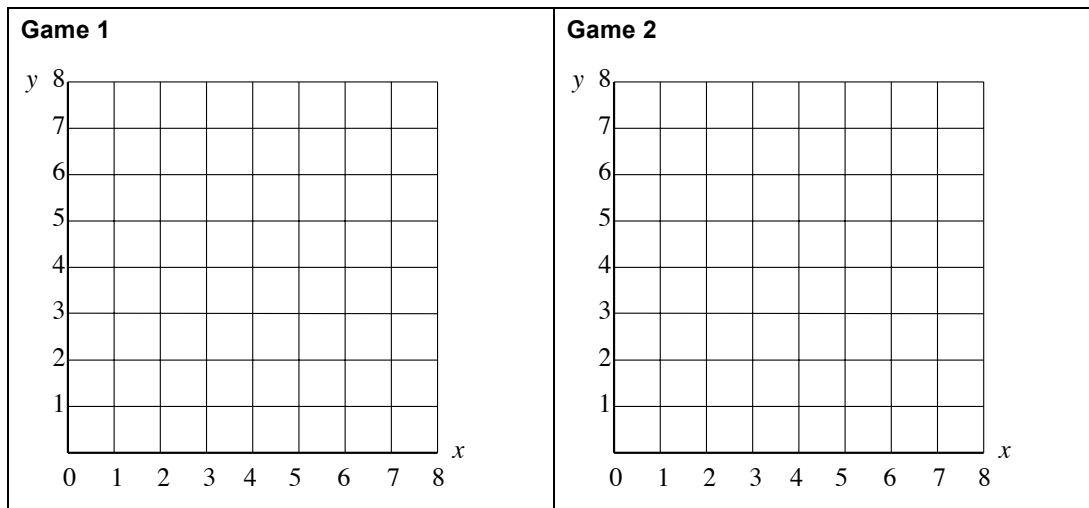

Use these graphs to invent your questions.

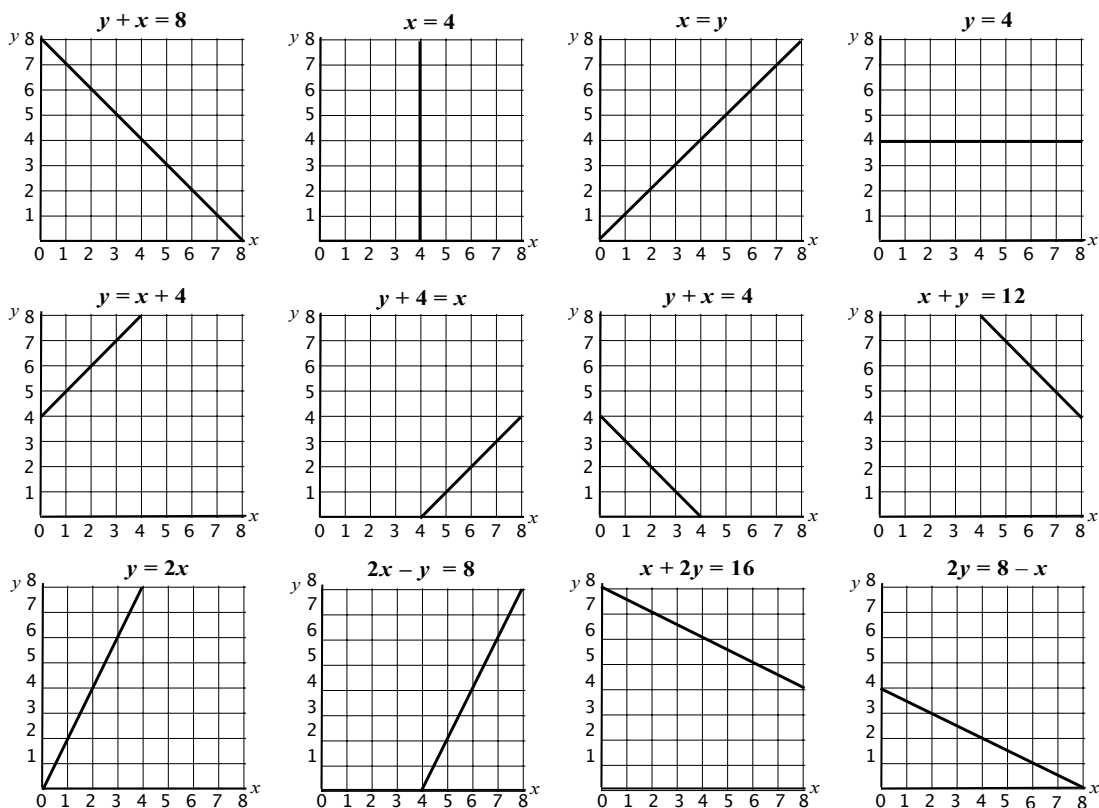

Hunting the Target

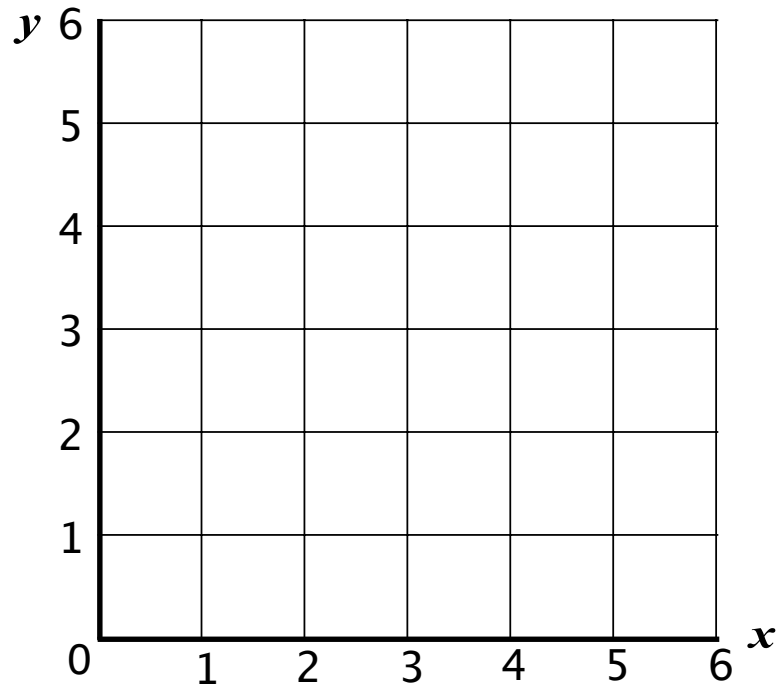

Projector Resources

Defining Regions Using Inequalities

P-1

Give Us a Clue

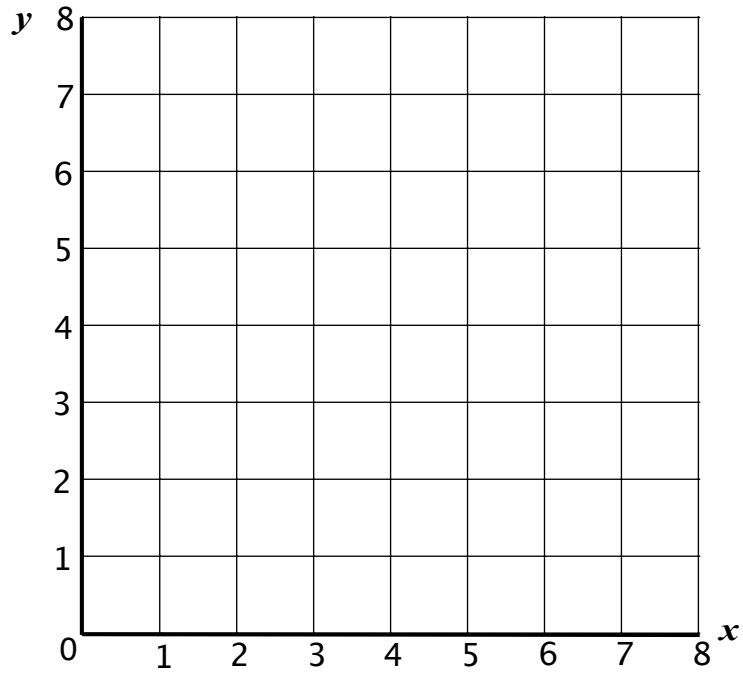

Projector Resources

Defining Regions Using Inequalities

P-2

Playing the Game

- One of you will be the target picker and the other the target hunter.
- The target picker decides on the position of the target and gives the clues.
- When giving clues, the target picker can use any inequality sign (\leq , $<$, \geq , $>$), but not the '=' sign. Try to give helpful clues!
As you give the clues, write them as a list on your mini-whiteboard.
- The target hunter uses the clues to find the target.
- The aim of the game for both partners, is to find the target in the least number of tries.
- Both partners must use a blank grid to keep track of the clues that are given.
- Each time a clue is given, shade out the region where the target cannot be located.

Mathematics Assessment Project
CLASSROOM CHALLENGES

This lesson was designed and developed by the
Shell Center Team
at the
University of Nottingham
Malcolm Swan, Nichola Clarke, Clare Dawson, Sheila Evans
with
Hugh Burkhardt, Rita Crust, Andy Noyes, and Daniel Pead

It was refined on the basis of reports from teams of observers led by
David Foster, Mary Bouck, and Diane Schaefer
based on their observation of trials in US classrooms
along with comments from teachers and other users.

This project was conceived and directed for
MARS: Mathematics Assessment Resource Service
by
Alan Schoenfeld, Hugh Burkhardt, Daniel Pead, and Malcolm Swan
and based at the University of California, Berkeley

We are grateful to the many teachers, in the UK and the US, who trialed earlier versions
of these materials in their classrooms, to their students, and to
Judith Mills, Carol Hill, and Alvaro Villanueva who contributed to the design.

This development would not have been possible without the support of
Bill & Melinda Gates Foundation
We are particularly grateful to
Carina Wong, Melissa Chabran, and Jamie McKee

© 2012 MARS, Shell Center, University of Nottingham
This material may be reproduced and distributed, without modification, for non-commercial purposes,
under the Creative Commons License detailed at <http://creativecommons.org/licenses/by-nc-nd/3.0/>
All other rights reserved.
Please contact map.info@mathshell.org if this license does not meet your needs.

Practice Together in Small Groups/Individually



INCLUDED IN THE STUDENT MANUAL

Task #16: Solution Sets

Given below are the graphs of two lines, $y = -0.5x + 5$ and $y = -1.25x + 8$, and several regions and points are shown. Note that C is the region that appears completely white in the graph.

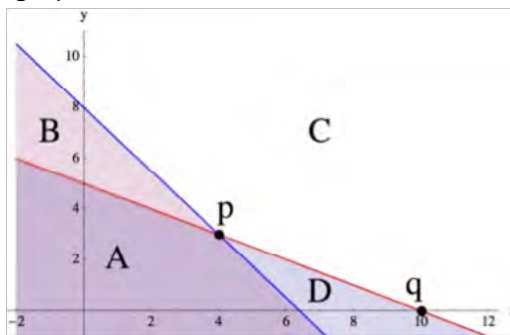

- For each region and each point, write a system of equations or inequalities, using the given two lines, that has the region or point as its solution set and explain the choice of \leq , \geq , or $=$ in each case. (You may assume that the line is part of each region.)
- The coordinates of a point within a region have to satisfy the corresponding system of inequalities. Verify this by picking a specific point in each region and showing that the coordinates of this point satisfy the corresponding system of inequalities for that region.
- In the previous part, we checked that specific coordinate points satisfied our inequalities for each region. Without picking any specific numbers, use the same idea to explain how you know that all points in the third quadrant must satisfy the inequalities for region A.

(<http://www.illustrativemathematics.org/illustrations/1205>)

Commentary for the Teacher:

The typical system of equations or inequalities problem gives the system and asks for the graph of the solution. This task turns the problem around. It gives a solution set and asks for the system that corresponds to it. The purpose of this task is to give students a chance to go beyond the typical problem and make the connections between points in the coordinate plane and solutions to inequalities and equations. Students have to focus on what the graph is showing. When you are describing a region, why does the inequality have to go one way or another? When you pick a point that clearly lies in a region, what has to be true about its coordinates so that it satisfies the associated system of inequalities?

The last part of this problem requires the students to make a general argument without using specific numbers and instead to recognize the structure of the inequalities.

The task could be used in many instructional settings, but having students share their thinking and respond to each other's' arguments would provide a rich learning experience.

Possible Solution:

The blue line has equation $y = -1.25x + 8$ and the red line has equation $y = -0.5x + 5$.

1. Region A: Since any point in region A lies on or below the red line and on or below the blue line, it has to be true that the point's y-coordinate has to be less than or equal to $-1.25x + 8$ and less than or equal to $-0.5x + 5$. Therefore, the system of inequalities which describes region A is:

$$y \leq -0.5x + 5$$
$$y \leq -1.25x + 8$$

Region B: Since any point in region B lies on or below the blue line and on or above the red line, it has to be true that the point's y-coordinate has to be less than or equal to $-1.25x + 8$ and greater than or equal to $-0.5x + 5$. Therefore, the system of inequalities which describes region B is:

$$y \leq -0.5x + 5$$
$$y \geq -1.25x + 8$$

Region C: Since any point in region C lies on or above the red line and on or above the blue line, it has to be true that the point's y-coordinate has to be greater than or equal to $-1.25x + 8$ and greater than or equal to $-0.5x + 5$. Therefore, the system of inequalities which describes region C is:

$$y \geq -0.5x + 5$$
$$y \geq -1.25x + 8$$

Region D: Since any point in region D lies on or below the red line and on or above the blue line, it has to be true that the point's y-coordinate has to be greater than or equal to $-1.25x + 8$ and less than or equal to $-0.5x + 5$. Therefore, the system of inequalities which describes region D is:

$$y \leq -0.5x + 5$$
$$y \geq -1.25x + 8$$

Point p: Since point p lies on the red line and also lies on the blue line, it has to be true that p's y-coordinate is equal to both $-1.25x + 8$ and to $-0.5x + 5$. Therefore, the system of equations which describes point p is:

$$y = -0.5x + 5$$
$$y = -1.25x + 8$$

Point q: Since point q lies on the red line and also lies on x-axis, it has to be true that q's y-coordinate is equal to both $-1.25x + 8$ and to 0. Therefore, the system of equations which describes point q is:

$$y = 0$$
$$y = -0.5x + 5$$

2. Many answers are possible. We give one for each region.

The point (0,0) lies in region A: Substituting this point into the inequalities we have,

$$\begin{aligned}0 &\leq -0.5 \times 0 + 5 = 5 \\0 &\leq -1.25 \times 0 + 8 = 8,\end{aligned}$$

which is true.

The point (0,6) lies in region B: Substituting this point into the inequalities we have,

$$\begin{aligned}6 &\geq -0.5 \times 0 + 5 = 5 \\6 &\leq -1.25 \times 0 + 8 = 8,\end{aligned}$$

which is true.

The point (8,10) lies in region C: Substituting this point into the inequalities we have,

$$\begin{aligned}10 &\geq -0.5 \times 8 + 5 = 1 \\10 &\geq -1.25 \times 8 + 8 = -2,\end{aligned}$$

which is true.

The point (10,-1) lies in region D: Substituting this point into the inequalities we have,

$$\begin{aligned}-1 &\leq -0.5 \times 10 + 5 = 0 \\-1 &\geq -1.25 \times 10 + 8 = -4.5,\end{aligned}$$

which is true.

3. We first observe that every point in the third quadrant has negative x- and y-coordinates. So we have to show that for any point with negative x and negative y coordinates, the two inequalities—

$$\begin{aligned}y &\leq -0.5x + 5 \\y &\leq -1.25x + 8,\end{aligned}$$

are satisfied.

Note that for any negative value of y, the left hand side of both inequalities will be negative. Similarly, for any negative value of x, the right hand side of both inequalities will be positive. It is true that any negative number is smaller than any positive number. Therefore, both inequalities are satisfied for negative values of x and y.

Evaluate Understanding

Have students review their original work from the previous lesson on the *Combining Inequalities* worksheet.

Closing Activity



INCLUDED IN THE STUDENT MANUAL

Task #17: Minimize Cost

You are the assistant manager of an electronics store. Next month you will order two types of tablet PCs. How many of each model (A or B) should you order to minimize your cost?

- Model A: Your cost is \$300 and your profit is \$40.
- Model B: Your cost is \$400 and your profit is \$60.
- You expect a profit of at least \$4,800.
- You expect to sell at least 100 units.

Minimize Cost Solution

You are the assistant manager of an electronics store. Next month you will order two types of tablet PCs. How many of each model (A or B) should you order to minimize your cost?

- Model A: Your cost is \$300 and your profit is \$40.
- Model B: Your cost is \$400 and your profit is \$60.
- You expect a profit of at least \$4,800.
- You expect to sell at least 100 units.

Let x = the number of Model A.

Let y = the number of Model B.

Minimize $300x + 400y$.

$$40x + 60y \geq 4800$$

$$x + y \geq 100$$

$$x \geq 0$$

$$y \geq 0$$

The dark green represents the feasible region.

Corner Points of the Feasible Region

(0, 100)

(120, 0)

(60, 40)

Cost

$$300(0) + 400(100) = \$40,000$$

$$300(120) + 400(0) = \$36,000$$

$$300(60) + 400(40) = \$34,000$$

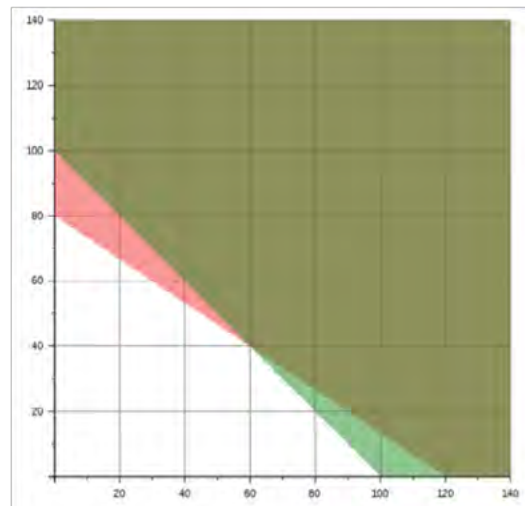

The assistant manager should order 60 Model A tablets and 40 Model B tablets.

Linear Systems of Equations

Lesson 6 of 6

Linear Programming

Description:

This lesson is the culmination of all lessons in this unit. It provides students with real-world problems in which they must solve problems to maximize revenue or minimize cost.

Georgia Standards of Excellence Addressed:

- MGSE9-12.A.CED.3: Represent constraints by equations or inequalities, and by systems of equations and/or inequalities, and interpret data points as possible (i.e. a solution) or not possible (i.e. a non-solution) under the established constraints.
- MGSE9-12.A.REI.12: Graph the solution set to a linear inequality in two variables

Standard(s) for Mathematical Practice Emphasized:

- SMP 1: Make sense of problems and persevere in solving them.
- SMP 4: Model with mathematics.

Sequence of
Instruction

Activities Checklist

Engage



This lesson develops conceptual understanding of linear programming by walking students through the process of linear programming. Along the way, students are asked to explain what is happening and why, which allows them to internalize the procedural skill necessary to solve linear programming problems.

The basis of this lesson is the Dirt Bike Dilemma activity sheet. Before attempting to use this material in class, be sure to look over the activity sheet and solve the problems on your own.

In particular, you should notice that the activity sheet requires the use of TI Graphing Calculators. If you intend to use this lesson with a different type of calculator or with a spreadsheet program, you will need to modify the activity packet before copying and distributing it to students.

Illuminations Dirt Bike Activity <http://illuminations.nctm.org/Lesson.aspx?id=2355>

INCLUDED IN THE STUDENT MANUAL

Task #18: Dirt Bike Dilemma

Dirt Bike Dilemma

NAME _____

The Annual Springfield Dirt Bike Competition is coming up, and participants are looking for bikes! Of course, they turn to Apu, who has the best bikes in town.

Apu has 18 wheels, 15 seats, and 14 exhaust pipes in his supply room. He can use these parts to assemble two different types of bikes: The Rider, or The Rover.

The Rider has 2 wheels, 1 seat, and 2 exhaust pipes. It is designed to glide around curves effortlessly.

The Rover has 3 wheels, 3 seats, and 1 exhaust pipe. It is designed to carry multiple passengers over the roughest terrain.

Apu needs to decide how many of each bike he should assemble to maximize his profit. Because of the popularity of the Dirt Bike Competition, he knows that no matter how many bikes he assembles, he will be able to sell all of them. Apu requests your assistance in making this decision.

Every member of your team should have the following items:

- Graphing Calculator
- Dirt Bike Dilemma Activity Sheet
- Three (3) Colored Pencils
- Set of Cards

In addition, each member of your team should get some cards:

- One member of your team should get 18 Wheel Cards. This person should complete Question 1.
- Another member of your team should get 14 Exhaust Pipe Cards. This person should complete Question 2.
- The last member of your team should get 15 Seat Cards. This person should complete Question 3.



© 2008 National Council of Teachers of Mathematics
<http://illuminations.nctm.org>

INCLUDED IN THE STUDENT MANUAL

1. Given 18 wheels, list all possible combinations of Riders and Rovers that can be assembled. Remember that each Rider needs two wheels and each Rover needs three wheels. Using only the wheel cards, complete the table. Plot the data on the grid below. (The possible combinations from the first two rows have been plotted for you.)

NUMBER OF RIDERS	POSSIBLE NUMBER OF ROVERS
0	0, 1, 2, 3, 4, 5, 6
1	0, 1, 2, 3, 4, 5
2	
3	
4	
5	
6	
7	
8	
9	

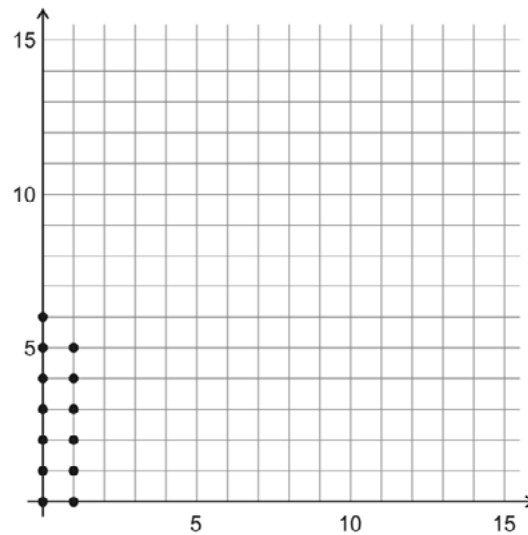

- a. What do you notice about the graph?

- b. On your graph, draw a line that borders all the points. This line should pass through *some* of the points that represent the maximum number of Rovers.

What inequality could be used to represent this relationship? _____
 This inequality is called a *restriction* or a *constraint*.

- c. How can you arrive at this inequality without the use of the table and graph?

INCLUDED IN THE STUDENT MANUAL

2. Given 14 exhaust pipes, list all possible combinations of Riders and Rovers that can be assembled. Remember that each Rider needs two exhaust pipes and each Rover needs one exhaust pipe. Using only the exhaust pipe cards, complete the table. Plot the data on the grid below. (The possible combinations from the first two rows have been plotted for you.)

NUMBER OF RIDERS	POSSIBLE NUMBER OF ROVERS
0	0, 1, 2, ..., 14
1	0, 1, 2, ..., 12
2	
3	
4	
5	
6	
7	

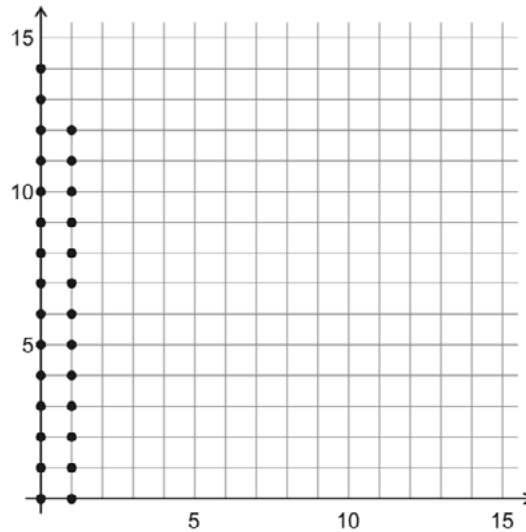

- a. What do you notice about the graph?

- b. On your graph, draw a line that borders all the points. This line should pass through *all* of the points that represent the maximum number of Rovers.

What inequality could be used to represent this relationship? _____
 This inequality is called a *restriction* or a *constraint*.

- c. How can you arrive at this inequality without the use of the table and graph?

INCLUDED IN THE STUDENT MANUAL

3. Given 15 seats, list all possible combinations of Riders and Rovers that can be assembled. Remember that each Rider needs one seat and each Rover needs three seats. Using only the seat cards, complete the table. Plot the data on the grid below. (The possible combinations from the first two rows have been plotted for you.)

NUMBER OF RIDERS	POSSIBLE NUMBER OF ROVERS
0	0, 1, 2, 3, 4, 5
1	0, 1, 2, 3, 4
2	
3	
4	
5	
6	
7	
8	
9	
10	
11	
12	
13	
14	
15	

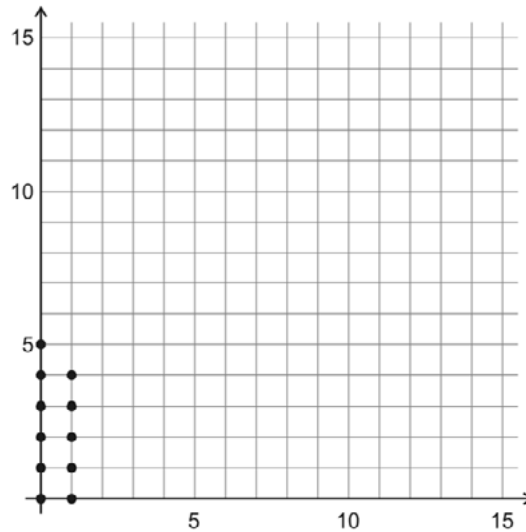

- a. What do you notice about the graph?

- b. On your graph, draw a line that encloses all the points. This line should pass through some of the points that represent the maximum number of Rovers.

What inequality would represent this relationship? _____
 This inequality is called a *restriction* or a *constraint*.

INCLUDED IN THE STUDENT MANUAL

- c. How can you arrive at this inequality without the use of the table and graph?

4. Discuss your answers with your team members. Explain how you arrived at your responses. Based on your discussion, complete Questions 1 through 3.

If all of the ordered pairs (Rider, Rover) that are feasible options are identified in the three graphs above, explain why each statement below is true.

- a. All ordered pairs have integer coordinates.

- b. When graphed in the coordinate plane, all ordered pairs will be located in either the first quadrant or on the positive x -axis or y -axis.

5. Below, list the three inequalities from Questions 1b, 2b, and 3b. Since all feasible ordered pairs (Rider, Rover) must be located either in the first quadrant or on one of the positive axes, what TWO additional inequalities should also be added to this list? Add them below.

INCLUDED IN THE STUDENT MANUAL

6. Put all of your cards together. As a team, using the cards and the information from Questions 1-3, determine all possible combinations of Riders and Rovers that can be assembled with 18 wheels, 15 seats, and 14 exhaust pipes. Remember that each Rider needs 2 wheels, 1 seat, and 2 exhaust pipes, and each Rover needs 3 wheels, 3 seats and 1 exhaust pipe. Complete the table below, and plot your data on the grid.

NUMBER OF RIDERS	POSSIBLE NUMBER OF ROVERS
0	
1	
2	
3	
4	
5	
6	
7	
8	
9	

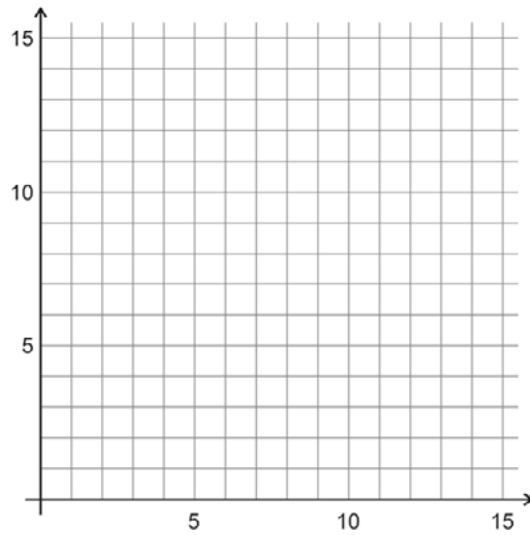

7. Carefully graph all five inequalities from Questions 5 on the grid in Question 6. What do you notice?

The region bounded by these inequalities is called the *feasible region*. The feasible region is the region that satisfies **all** of the constraints.

INCLUDED IN THE STUDENT MANUAL

8. Suppose Apu makes a profit of \$15 for each Rider and \$30 for each Rover. Select two points from the feasible region to determine the total profit that Apu would receive. Show how you arrived at your answers.

a. First point in the feasible region: (_____ , _____)

b. Second point in the feasible region: (_____ , _____)

9. If Apu makes a profit of \$15 on each Rider and \$30 on each Rover, write an expression to represent the total profit he receives. Let x represent the number of Riders he sells, and let y represent the number of Rover he sells.

Total Profit = _____

This function is known as an *objective function*. The objective function is the function that you are trying to maximize or minimize. (In this case, the objective is to maximize Apu's profit.)

10. Apu makes a profit of \$15 for each Rider and \$30 for each Rover.

- a. Find three ordered pairs in which the total profit earned would be \$90, \$120, or \$180. (The points you select do not have to be in the feasible region.)

PROFIT	ORDERED PAIRS		
\$90	(_____ , _____)	(_____ , _____)	(_____ , _____)
\$120	(_____ , _____)	(_____ , _____)	(_____ , _____)
\$180	(_____ , _____)	(_____ , _____)	(_____ , _____)

INCLUDED IN THE STUDENT MANUAL

- b. On the grid below, plot each set of points (those for a total profit of \$90, those for a total profit of \$120, and those for a total profit of \$180) in a different color. Each set of three points should form a straight line. Why does this make sense?

Draw a line through each set of points. What do you notice about these lines? Why does this make sense?

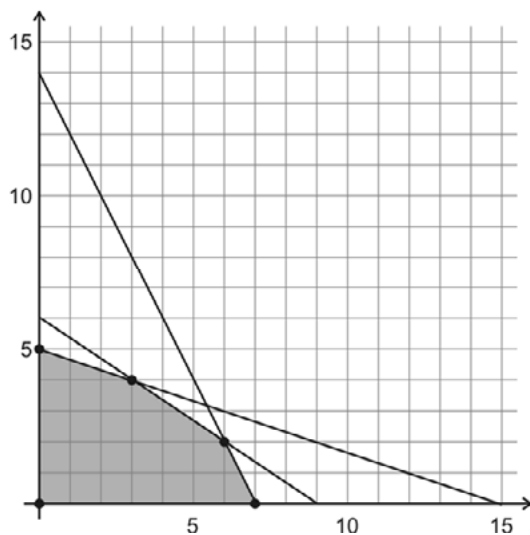

- c. Does one of these values — \$90, \$120, or \$180 — represent the MAXIMUM total profit that Apu can earn if he receives a profit of \$15 for each Rider and \$30 for each Rover? Explain your reasoning.

INCLUDED IN THE STUDENT MANUAL

11. Using the TI-83+ or TI-84+ Graphing Calculator, follow the steps outlined below.

- a. Press **PRGM**. Use the down cursor key to highlight **DRTBK**. Press **ENTER**. Press **STAT**. Press **ENTER**.
- b. Use the up cursor key to highlight **L1**. Press **2nd** **DEL**. Press **2nd** **STAT**. Use the down cursor key to highlight **RIDER**. Press **ENTER** twice. This column represents the number of Riders sold.
- c. Use the right and up cursor key to highlight **L1**. Press **2nd** **DEL**. Press **2nd** **STAT**. Use the down cursor key to highlight **ROVER**. Press **ENTER** twice. This column represents the corresponding number of Rovers sold.
- d. Use the right and up cursor key to highlight **L1**. Press **2nd** **DEL**. Press **2nd** **STAT**. Use the down cursor key to highlight **TPRFT**. Press **ENTER** twice. This column represents the Total Profit received.
- e. Use the right and up cursor key to highlight **L1**. Press **2nd** **DEL**. Press **2nd** **STAT**. Use the down cursor key to highlight **PRFIT**. Press **ENTER** twice. The first number in this column represents the profit earned for each Rider sold and the second number represents the profit earned for each Rover sold.
- f. Use the up cursor key to highlight the number below **PRFIT**. Type in a value for the profit Apu receives for each Rider he assembles. Press **ENTER**. Type in a value for the profit Apu receives for each Rover he assembles. Press **ENTER**.

In **Step f**, enter 15 as the profit for each Rider and 30 as the profit for each Rover. Move the cursor to the **TPRFT** column. Use the cursor key to find the *maximum total profit* (the largest number in this column).

Record this value in the appropriate space in the table below. Along with this value, record the corresponding values for Riders and Rovers. To change the profit earned on each Rider and Rover, move to the **PRFIT** column and repeat **Step f**. Complete the table below choosing your own values for the last several rows.

PROFIT ON EACH RIDER	PROFIT ON EACH ROVER	NUMBER OF RIDERS	NUMBER OF ROVERS	MAXIMUM TOTAL PROFIT
\$15	\$30			
\$20	\$20			
\$10	\$40			

INCLUDED IN THE STUDENT MANUAL

Compare your results with those of your team members. Which combinations of **(Rider, Rover)** always appear?

Where are these points located on your graph in Question 6?

Given all the points in the feasible region, why do you think that just one **(Rider, Rover)** combination always yields the maximum profit?

12. Using your graphing calculator, follow the steps below.

- Step 1:** Press **APPS**. Press the up cursor key. Use the down cursor key to highlight **TRANSFRM**. Press **ENTER** twice.
- Step 2:** Press **WINDOW**. Press the up cursor key. Use the down cursor key to highlight step. Type in 5. Press **ENTER**. Press **GRAPH**.
- Step 3:** Use the up or down cursor key to move to **A**. Enter 15. Press **ENTER**. **A** represents the profit earned for each Rider. Use the down cursor key to move to **B**. Enter 30. **B** represents the profit earned for each Rover. Press **ENTER**. Use the down cursor to move to **C**. Type in 0. Press **ENTER**. **C** represents the total profit earned.
- Step 4:** Use the right cursor key to increase the value of **C**. Watch the line on your graph.

a. As the line moves, what is the last point in the feasible region through which the line passes?

(_____ , _____)

b. What is the value of **C** at this point? _____

c. Repeat **Steps 3** and **4** for different values of **A** and **B**. As a team, come up with an explanation for why the corner points of the feasible region always yield the maximum (or minimum) profit.

INCLUDED IN THE STUDENT MANUAL

15. Use your steps from Question 14 to solve the problem below.

Lisa is making cookies to sell at the Annual Dirt Bike Competition. A dozen oatmeal cookies require 3 cups of flour and 2 eggs. A dozen sugar cookies require 4 cups of flour and 1 egg. She has 40 cups of flour and 20 eggs. She can make no more than 9 dozen oatmeal cookies and no more than 7 dozen sugar cookies, and she earns \$3 for each dozen oatmeal cookies and \$2 for each dozen sugar cookies. How many dozens of each type of cookie should she make to maximize her profit?

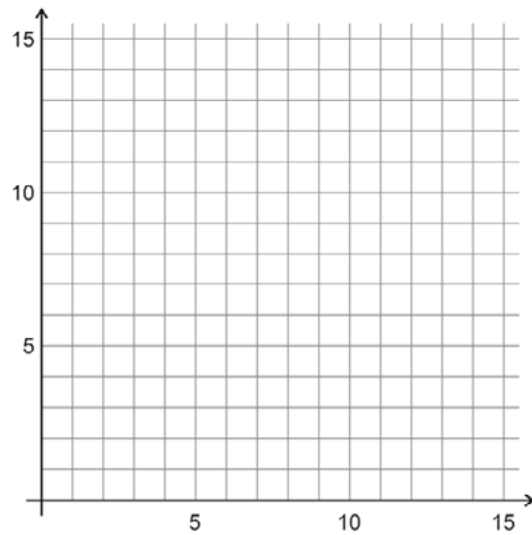

Divide the class into teams of three students. One member of the team should be given all of the Wheel cards; this team member is responsible for completing Question 1 on the activity sheet. Similarly, another team member should be given all of the Exhaust Pipe cards and complete Question 2, and the last team member should receive all of the Seat cards and complete Question 3.

This lesson is designed to guide students to discover and consolidate the concepts associated with solving linear programming problems. Your role as teacher is to assess their understanding and provide assistance if they encounter difficulties. Move from one team to another, listening to the discussions. Encourage students to work cooperatively; try to refrain from answering individual student questions, especially those that can be answered by the team.

Read the problem out loud to your students. Ask a student to describe the problem in his or her own words.

The first part of the lesson (Questions 1-3) asks the students to work independently. Basically, Questions 1-3 deal with the same concepts. Each team member is asked to complete a table and graph, relating the number of Rovers that can be assembled given the number of Riders that have been assembled, based on the number of wheels, exhaust pipes, or seats. The purpose of these questions is to help the student visualize the problem and to come up with the constraints for the linear programming problem that they will solve.

Explore

Illuminations Dirt Bike Activity <http://illuminations.nctm.org/LessonDetail.aspx?id=L685>

Randomly ask different teams to explain how they arrived at their responses, especially to Questions 7, 9, 10, 12, 13, and 14. If you are not satisfied with their response, ask some probing questions, such as the following:

- What happens if I select a point outside the feasible region?
- Can the corner points also tell me the combination that will give the minimum profit?

Continue to question until you feel that they are making a connection. Visit each group at least once.

Bring the class together after most teams have completed Question 10. Go through the steps with the class of how to set up and use the DRTBK program. (The procedure for using this program is found in Question 11 on the activity sheet.) Also, go through the first three steps of using the Transformation Graphing Apps. (These steps are found in Question 12 on the activity sheet.) When completing the table in Question 11, tell your students if the maximum value occurs more than once, they should write down both combinations.

When all teams have completed Questions 1 through 13, have a whole class discussion. Use the questions from the 'Questions For Students' section.

On the board or overhead projector, list all of the responses to Question 14 which states, "List five major steps required to solve a linear programming problem." After all responses have been collected, allow the class to narrow the list down to the five major steps.

Allow the class to complete Question 14 on the activity sheet. This can be done with the time remaining in class or as a homework assignment. If used as a homework assignment, the solution should be discussed the next day.

Explanation

Illustrations Dirt Bike Activity <http://illuminations.nctm.org/LessonDetail.aspx?id=L685>

Questions for Students:

What is a feasible region?

[The *feasible region* is the region formed by the intersection of all of the constraints.]

What is an objective function? [An *objective function* is function for which you are trying to find the minimum or maximum value.]

Why must the corner points of the feasible region produce the maximum or minimum value of the objective function? [The corner points of the feasible region produces the maximum or minimum value of the objective function because as the y intercept of the objective function line increases (or decreases), the last point it encounters as it leaves the feasible region is one of the corner points.]

Are there times when no unique point will minimize or maximize an objective function? If so, when? If not, why not? [There are times when there is no unique point that will minimize or maximize an objective function. This occurs when the objective function lines are parallel to one of the sides of the feasible region. Therefore, as the y intercept of the objective function line increases (or decreases), the last object it encounters is a line segment and not a single point. In this case, there will be multiple points that yield the maximum (or minimum) value.]

What are the five major steps necessary for solving linear programming problems?

[The five major steps for solving a linear programming problem are:

1. Determine the inequalities that represent the constraints.
2. Graph the feasible region.
3. Determine the corner points of the feasible region.
4. Determine the objective function.
5. Substitute the coordinates of the corner points into the objective function to determine which yields the maximum (or minimum) value.

Note that student lists may appear differently, but they should contain these same basic ideas.]

Practice Together in Small Groups/Individually

Students should work in groups of two to three to solve these problems. The questions below can be found at Linear Programming Practice .

INCLUDED IN THE STUDENT MANUAL

Task #19: Linear Programming Practice

1. The Kappa Beta fraternity has 200 sweatshirts and 100 pairs of sweatpants available to sell. During rush week, they decided to offer two package deals to students. Package A has one sweatshirt and one pair of sweatpants for \$30.

Package B has three sweatshirts and one pair of sweatpants for \$50. The fraternity wants to sell at least 20 of Package A and at least 10 of Package B. How many of each package type must they sell in order to maximize their revenue?

- A hospital dietician wishes to prepare a corn-squash vegetable dish that will provide at least three grams of protein and cost no more than \$0.35 per serving. An ounce of cream corn provides $\frac{1}{2}$ gram of protein and costs \$0.04. An ounce of squash supplies $\frac{1}{4}$ gram of protein and costs \$0.03. For taste, there must be at least two ounces of corn and at least as much squash as corn. It is important to keep the total number of ounces in a serving as small as possible. Find the combination of corn and squash that will minimize the amount of ingredients used per serving.

Evaluate Understanding

Linear Programming Practice Solutions

- The Kappa Beta fraternity has 200 sweatshirts and 100 pairs of sweatpants available to sell. During rush week, they decided to offer two package deals to students. Package A has one sweatshirt and one pair of sweatpants for \$30. Package B has three sweatshirts and one pair of sweatpants for \$50. The fraternity wants to sell at least 20 of Package A and at least 10 of Package B. How many of each type package must they sell in order to maximize their revenue?

Let x = the number of Package A.

Let y = the number of Package B.

Maximize $30x + 50y$.

$$x + 3y \leq 200$$

$$x + y \leq 100$$

$$x \geq 20$$

$$y \geq 10$$

The feasible region is the darkest green area toward the bottom left corner.

Corner Points of the Feasible Region

(20, 10)

(90, 10)

(50, 50)

(20, 60)

Revenue

$$30(20) + 50(10) = \$1100$$

$$30(90) + 50(10) = \$3200$$

$$30(50) + 50(50) = \$4000$$

$$30(20) + 50(60) = \$3600$$

They must sell 50 of each package to maximize revenue.

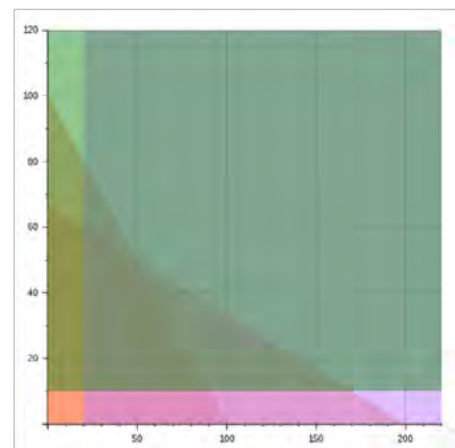

2. A hospital dietician wishes to prepare a corn-squash vegetable dish that will provide at least three grams of protein and cost no more than \$0.35 per serving. An ounce of cream corn provides 1/2 gram of protein and costs \$0.04. An ounce of squash supplies 1/4 gram of protein and costs \$0.03. For taste, there must be at least two ounces of corn and at least as much squash as corn. It is important to keep the total number of ounces in a serving as small as possible. Find the combination of corn and squash that will minimize the amount of ingredients used per serving.

Let x = ounces of cream corn.

Let y = ounces of squash.

Minimize $x + y$.

$$0.5x + 0.25y \geq 3$$

$$0.04x + 0.03y \leq .35$$

$$x \geq 2$$

$$y \geq x$$

The feasible region is the quadrilateral in the darkest shade of blue. The feasible region is graphed by itself below.

Feasible Region

Corner Points of the Feasible Region

(4, 4)

(5, 5)

(2, 9)

(2, 8)

Amount of Ingredients

$$4 + 4 = 8$$

$$5 + 5 = 10$$

$$2 + 9 = 11$$

$$2 + 8 = 10$$

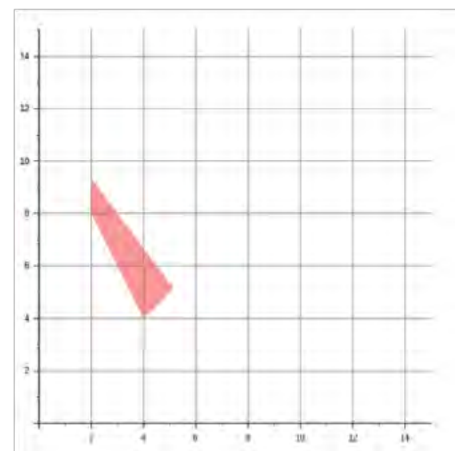
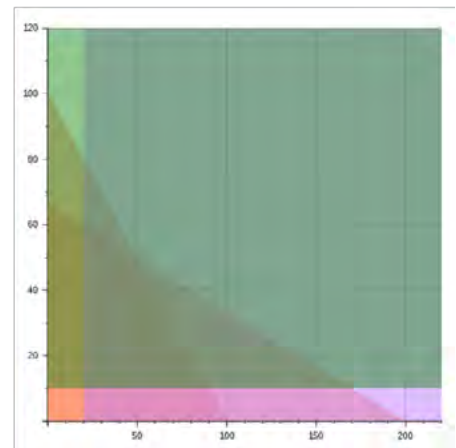

The hospital should use four ounces of corn and four ounces of squash.

Closing Activity

Students should work independently on this problem.

INCLUDED IN THE STUDENT MANUAL

Task #20: Jackson's Party

Jackson is buying wings and hot dogs for a party. Hotdogs cost \$4 per pound and a package of wings costs \$7. He has at most \$56 to spend on meat. Jackson knows that he will buy at least five pounds of hot dogs and at least two packages of wings. List and justify at least two solutions for the number of packages of wings and pounds of hot dogs Jackson could buy.

Jackson's Party Solution

Jackson is buying wings and hot dogs for a party. Hotdogs cost \$4 per pound and a package of wings costs \$7. He has at most \$56 to spend on meat. Jackson knows that he will buy at least five pounds of hot dogs and at least two packages of wings. List and justify at least two solutions for the number of packages of wings and pounds of hot dogs Jackson could buy.

Let x = the number of pounds of hotdogs.

Let y = the number of packages of wings.

$$4x + 7y \leq 56$$

$$x \geq 5$$

$$y \geq 2$$

The feasible region is the dark green triangle. Students should select points inside or on the boundary of the triangle.

Some possible solutions include:

- Six pounds of hotdogs and four packages of wings.
- Five pounds of hotdogs and four packages of wings.

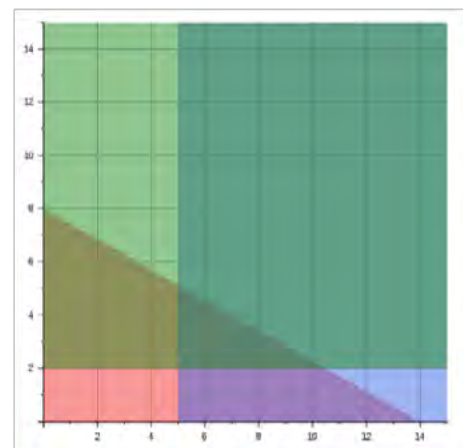

SREB Readiness Courses
Transitioning to college and careers

College Readiness Mathematics

Unit 5 . Linear Systems
of Equations
Student Manual
Version 3

Name

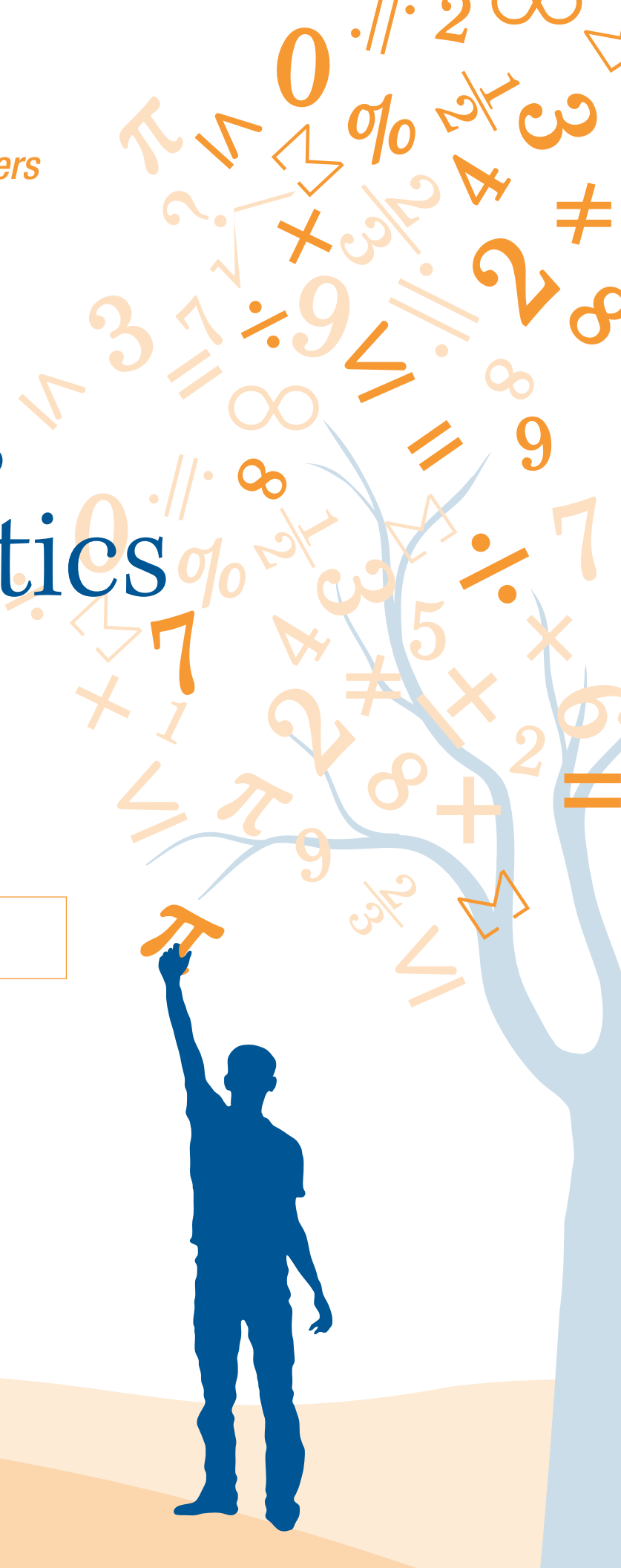

Unit 5 . Linear Systems of Equations

Table of Contents

Pre-Unit Assessment	3
Lesson 1.....	4
Lesson 2.....	14
Lesson 3.....	18
Lesson 4.....	25
Lesson 5.....	28
Lesson 6.....	43

Entry Event Activity

Wartime Battle

During war games, it is your job to navigate one of our battleships. Your course takes you over several enemy paths. As part of your duties, you must lay mines along the enemy's path. However, in order to plant the mines, you must know the points at which the paths cross and report those points to the Captain and to the Mine Crew. You know of 3 different enemy paths, which are denoted by the following equations:

Enemy Path 1: $x = 3y - 15$

Enemy Path 2: $4x - y = 7$

Enemy Path 3: $y = -1 - 2x$

Your battleship's course is denoted by this equation:

Battleship: $x + y = -5$

Using graph paper and colored pencils, determine where you need to plant the mines.

	(x, y) intersection
Enemy Path 1	
Enemy Path 2	
Enemy Path 3	

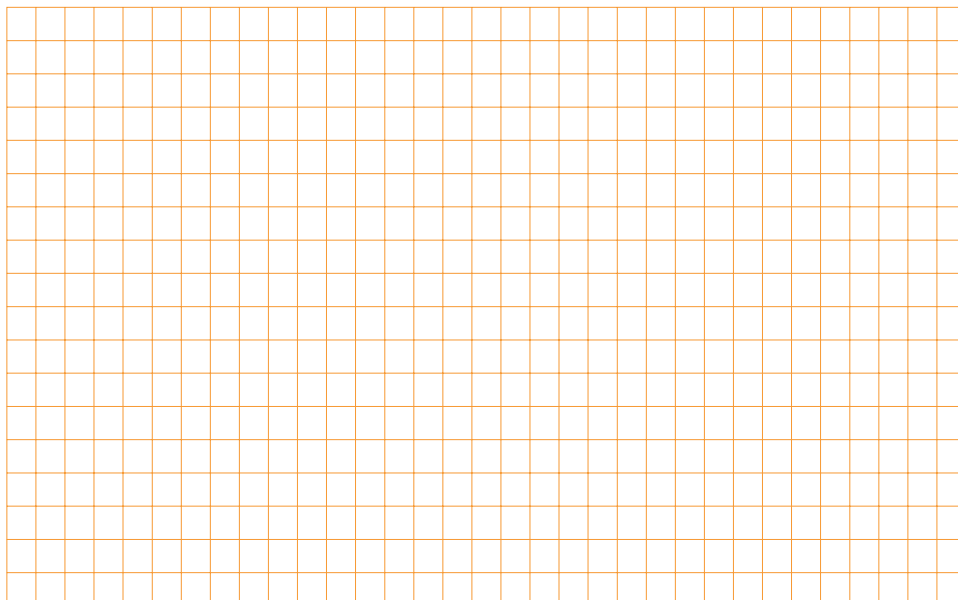

Task #2: Systems Activity

Work in teams of three or four (person A, person B, and person C). Each student is to complete his or her worksheet using the method as prescribed on the sheet, showing all work for each problem.

When you are finished, compare solutions for each corresponding system. Write the agreed upon solution in the appropriate column. Then discuss how you arrived at your solution. Was the method you used easier or more difficult than the others? Decide which method or methods the group found to be the 'best' or 'preferred' for each system (graphing, substitution or elimination). Give a reason for your answer. Simply saying, "it was the easiest method," is not sufficient. Explain WHY you found the method to be the best—what made it easier?

SYSTEM	Solution	Preferred Method(s)	Reason
System 1 $\begin{cases} x + y = 4 \\ 2x - y = 5 \end{cases}$			
System 2 $\begin{cases} y = 4x + 6 \\ 2x - 3y = 7 \end{cases}$			
System 3 $\begin{cases} 3x + 2y = 8 \\ 5x - 3y = 7 \end{cases}$			

Person A

Graphing Method

$x + y = 4$

$2x - y = 5$

Substitution Method

$y = 4x + 6$

$2x - 3y = 7$

Elimination Method

$3x + 2y = 8$

$5x - 3y = 7$

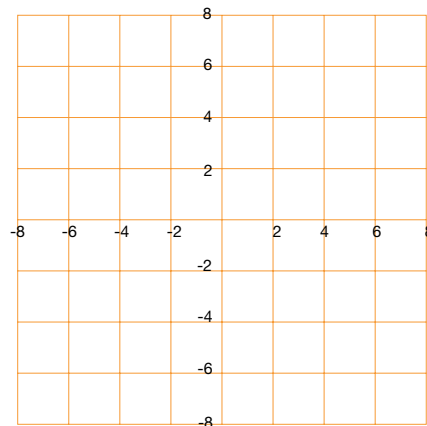

Person B

Graphing Method

$$3x + 2y = 8$$

$$5x - 3y = 7$$

Substitution Method

$$x + y = 4$$

$$2x - y = 5$$

Elimination Method

$$y = 4x + 6$$

$$2x - 3y = 7$$

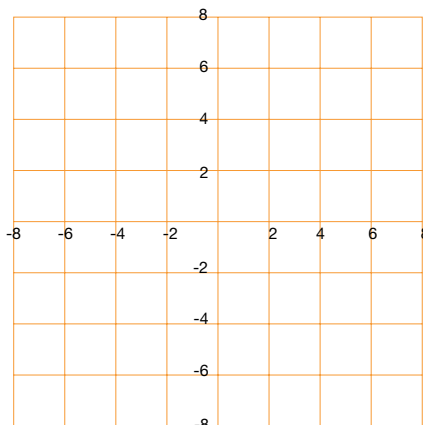

Person C

Graphing Method

$$y = 4x + 6$$

$$2x - 3y = 7$$

Substitution Method

$$3x + 2y = 8$$

$$5x - 3y = 7$$

Elimination Method

$$x + y = 4$$

$$2x - y = 5$$

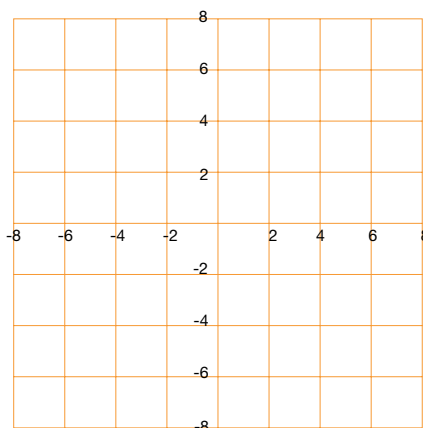

Task #3: Classifying Solutions

Solve each system of equations in the following ways:

- a) Graphing.
- b) Algebraically— substitution or elimination (addition).

1) $2x + 3y = 9$
 $-4x - 6y = -18$

a. Solve graphically.

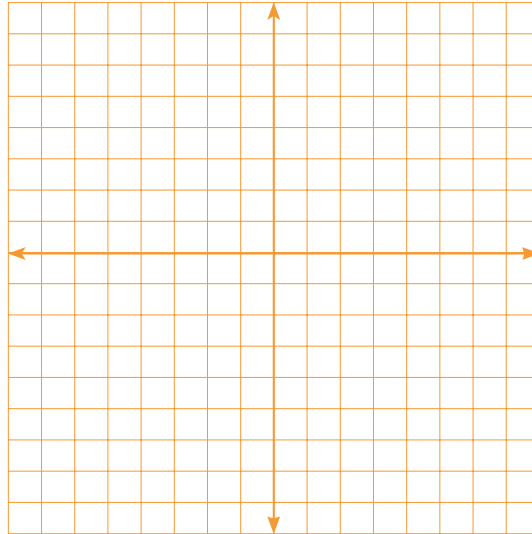

b. Solve algebraically.

c. What do you notice about the lines?

d. What is the solution? Where do the lines intersect? How many solutions exist?

e. Is the system consistent or inconsistent? Are the equations dependent or independent?

2) $x - 2y = 8$
 $3x - 6y = 6$

a. Solve graphically.

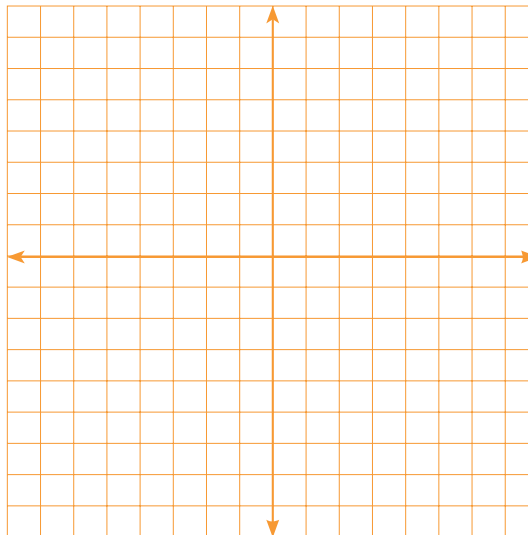

b. Solve algebraically.

c. What do you notice about the lines?

d. What is the solution? Where do the lines intersect? How many solutions exist?

e. Is the system consistent or inconsistent? Are the equations dependent or independent?

3) $-x + y = -2$
 $3x + y = 2$

a. Solve graphically.

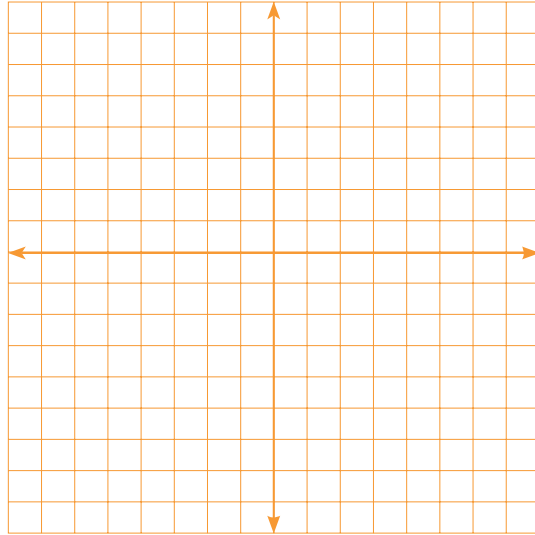

b. Solve algebraically.

c. What do you notice about the lines?

d. What is the solution? Where do the lines intersect? How many solutions exist?

e. Is the system consistent or inconsistent? Are the equations dependent or independent?

Task #4: Systems of Equations Practice Problems

Solve the following systems of equations by any method. Indicate if there is no solution or infinitely many solutions.

1. $2y - 4 = 0$
 $x + 2y = 5$

2. $3x + 8y = 18$
 $x + 2y = 4$

3. $2y - 4x = -4$
 $y = -2 + 2x$

4. $2x - 4y = 5$
 $3x + 5y = 2$

5. $f(x) = -4x + 15$
 $g(x) = 3x - 6$

6. $3y = 6 + x$
 $3x - 9y = 9$

7. $3x - 5y = 1$
 $7x - 8y = 17$

8. $y = -\frac{3}{4}x$
 $3x + 2y = 6$

Task #5: Best Buy Tickets

Susie is organizing the printing of tickets for a show her friends are producing. She has collected prices from several printers and these two seem to be the best. Susie wants to go for the best buy. She doesn't yet know how many people are going to come. Show Susie a couple of ways in which she could make the right decision, whatever the number. Illustrate your advice with a couple of examples.

SURE PRINT
Ticket printing
25 tickets for \$2

BEST PRINT

Tickets printed
\$10 setting up
plus
\$1 for \$25 tickets

Task #6: Dimes and Quarters and Sum of Digits

1) The only coins that Alexis has are dimes and quarters. Her coins have a total value of \$5.80. She has a total of 40 coins. How many does she have of each coin?

(<http://www.illustrativemathematics.org/illustrations/220>)

2) The sum of the digits of a two-digit number is seven. When the digits are reversed, the number is increased by 27. Find the number.

Stapel, Elizabeth. "System-of-Equations Word Problems." Purplemath. Available from <http://www.purplemath.com/modules/systprob.htm>. Accessed 17 September 2012

Task #8: How Many Solutions?

Consider the equation $5x - 2y = 3$. If possible, find a second linear equation to create a system of equations that has:

- Exactly one solution.
- Exactly two solutions.
- No solutions.
- Infinitely many solutions.

Bonus Question: In each case, how many such equations can you find?

(Source: Illustrative Mathematics)

Task #9: Zoo

To enter a zoo, adult visitors must pay \$5, whereas children and seniors pay only half price. On one day, the zoo collected a total of \$765. If the zoo had 223 visitors that day, how many half-price admissions and how many full-price admissions did the zoo collect?

Task #10: Part I: BurgerRama Cartoon Dolls

Joan King is marketing director for the BurgerRama restaurant chain. BurgerRama has decided to have a cartoon-character doll made to sell at a premium price at participating BurgerRama locations. The company can choose from several different versions of the doll that sell at different prices. King’s problem is to decide which selling price will best suit the needs of BurgerRama’s customers and store managers. King has data from previous similar promotions to help her make a decision.

Selling Price of Each Doll	Number Supplied per Week per Store	Number Requested per Week per Store
\$1.00	35	530
\$2.00	130	400
\$4.00	320	140

1. Use the data from the table above to plot points representing selling price and supply price on a graph. (Selling Price of Each Doll should appear on the x-axis, and Number of Dolls Per Week per Store should appear on the y-axis.) Draw the line through the data points and write the word “Supply” on this line.
2. Plot points representing selling price and number requested (demand) on the same graph. Draw the line through these points. Write the word “Demand” on this line.

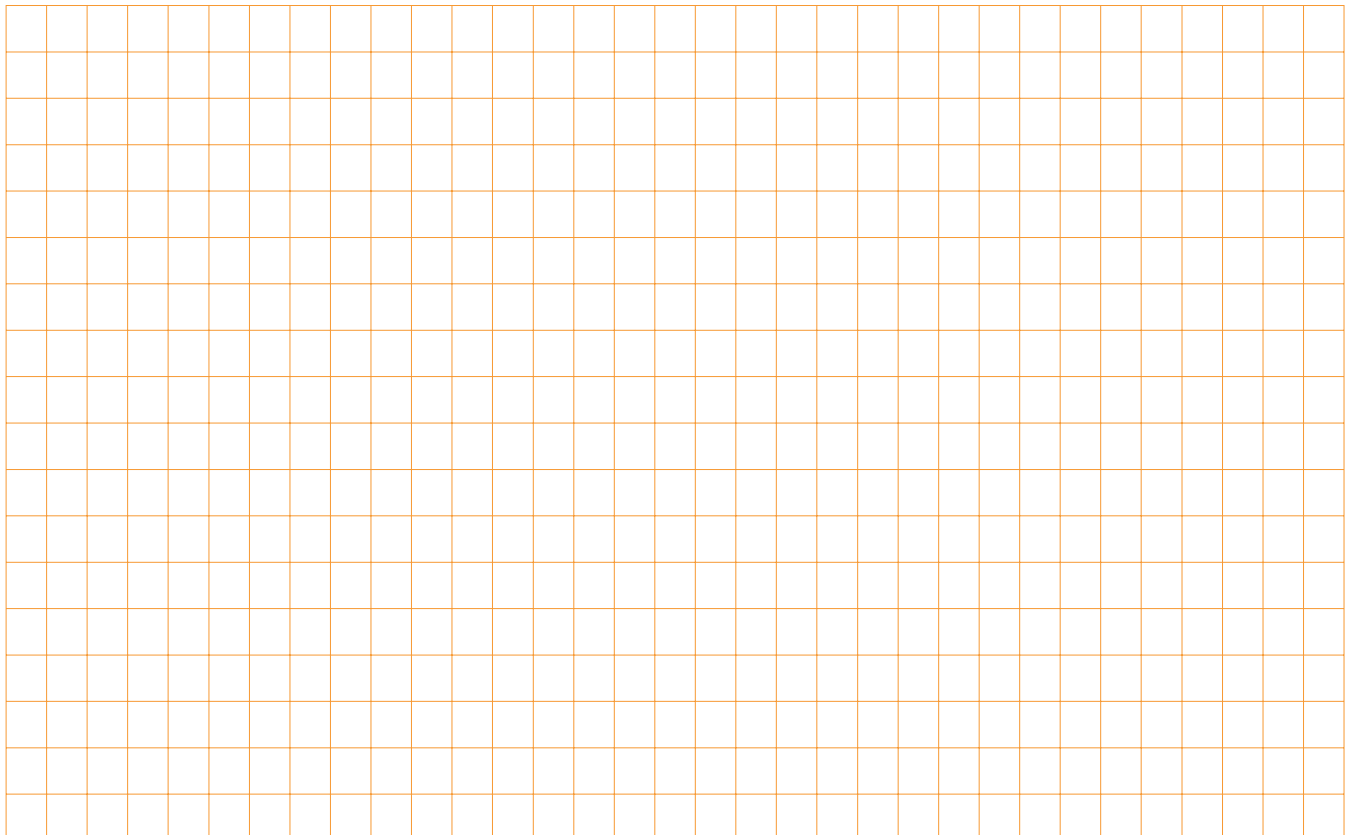

3. Use your graph to answer the following questions.

a. If King sets the price at \$2.50 per doll, how many disappointed customers will each store have during the week?

b. If King sets the price at \$3.80 per doll, how many unsold dolls will remain at each store at the end of a week?

c. According to this graph, if the company could give the dolls away, how many would each store need per week?

d. According to this graph, what price would make the doll supply so tight that the average number available to each store would be zero?

e. Estimate the price where supply and demand will be in equilibrium.

4. Complete the following using equations:

a. Use two of the points given to find the equation for supply (S) as a function of price (P).

b. Use two of the points given to find the equation for demand (D) as a function of price (P).

c. Solve the system of supply-and-demand equations to find the price in exact equilibrium. How does this price compare with your answer in question 3e above?

Task #11: Solving Problems with Two or More Equations

1. Which is the better value when renting a vehicle? Show your work or explain your answer.

Rent-A-Hunk o’ Junk charges \$29.95 per day and 43¢ per mile.

Tom’s Total Wrecks charges \$45 per day plus 32¢ per mile.

2. A landscaping company placed two orders with a nursery. The first order was for 13 bushes and four trees, and totaled \$487. The second order was for six bushes and two trees, and totaled \$232. The bills do not list the per-item price. What were the costs of one bush and of one tree? Show your work or explain your answer.

3. Below is data on four cyclists riding along a road through the Black Hills. The variable x represents the time the cyclist has been riding and y represents the cyclist’s distance in kilometers from Rapid City. Not all of the cyclists started their ride at Rapid City, but all of them left at the same time and are riding in the same direction.

Dan:

Hours	Kilometers
1	70
4	145

Maria:

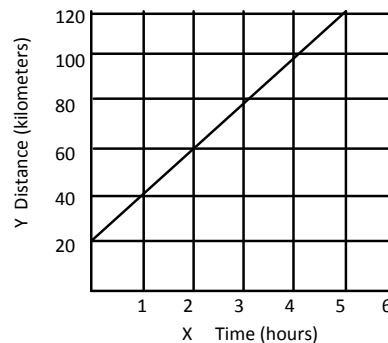

Ryan: $y = 30x$.

Helen: Started cycling 15 kilometers from Rapid City and traveled 50 kilometers in two hours.

a) Who is cycling the fastest? Who is cycling the slowest? Explain.

b) Will Ryan pass Dan? If so, when?

c) Will Helen pass Maria? If so, when?

d) Will Helen pass Dan? If so, when?

e) Write a linear equation for each of the cyclists. Graph the equations using graph paper or a graphing calculator. Explain how the graphs relate to your answers above.

Task #12 (contd.): Part III Silver Dollars

Yousef likes to buy and sell coins at the flea market on weekends. He is especially interested in Susan B. Anthony silver dollars. By his own trial-and-error experiences and by information gained from other traders, Yousef has found the following data:

Selling Price	Number in Supply	Number in Demand
\$1.40	10	90
\$2.00	19	50
\$3.00	42	25
\$4.20	94	20

1. On graph paper, graph the price-supply points.
2. On the same graph, graph the price-demand points.
3. Use the graph to estimate the price in equilibrium.
4. Sketch a line that comes close to containing the price-supply points.
5. Sketch a line that comes close to containing the price-demand points.
6. What are the coordinates of the point where these two lines intersect? How does this answer compare with your answer in question 3?

Task #13: Boomerangs

Phil and Cath make and sell boomerangs for a school event. The money they raise will go to charity. They plan to make them in two sizes—small and large.

- Phil will carve them from wood. The small boomerang takes two hours to carve and the large one takes three hours to carve. Phil has a total of 24 hours available for carving.
- Cath will decorate them. She only has time to decorate 10 boomerangs of either size.
- The small boomerang will make \$8 for charity. The large boomerang will make \$10 for charity.

They want to make as much money for charity as they can. How many small and large boomerangs should they make? How much money will they then make?

Task #14: Writing Constraints

In (a)–(d), (i) write a constraint equation, (ii) determine two solutions, and (iii) graph the equation and mark your solutions.

a. The relation between quantity of chicken and quantity of steak if chicken costs \$1.29/lb and steak costs \$3.49/lb and you have \$100 to spend on a barbecue.

b. The relation between the time spent walking and driving if you walk at 3 mph then hitch a ride in a car traveling at 75 mph, covering a total distance of 60 miles.

Source: Illustrative Mathematics

c. The relation between the volume of titanium and iron in a bicycle weighing 5 kg, if titanium has a density of 4.5g/cm^3 and iron has a density of 7.87g/cm^3 (ignore other materials).

d. The relation between the time spent walking and the time spent canoeing on a 30 mile trip if you walk at 4 mph and canoe at 7 mph.

Task #15: Fishing Adventure 3

Fishing Adventures rents small fishing boats to tourists for day long fishing trips. Each boat can hold at most eight people. Additionally, each boat can only carry 1200 pounds of people and gear for safety reasons. Assume on average an adult weighs 150 pounds and a child weighs 75 pounds. Also, assume each group will require 200 pounds of gear plus 10 pounds of gear per person.

- Write an inequality that illustrates the weight limit for a group of adults and children on the fishing boat and a second inequality that represents the total number of passengers in the fishing boat. Graph the solution set to the inequalities.

- Several groups of people wish to rent a boat. Group 1 has four adults and two children. Group 2 has three adults and five children. Group 3 has eight adults. Which of the groups, if any, can safely rent a boat? What other combinations of adults and children are possible?

(Source: Illustrative Mathematics)

- The coordinates of a point within a region have to satisfy the corresponding system of inequalities. Verify this by picking a specific point in each region and showing that the coordinates of this point satisfy the corresponding system of inequalities for that region.

In the previous part, we checked that specific coordinate points satisfied our inequalities for each region. Without picking any specific numbers, use the same idea to explain how you know that all points in the third quadrant must satisfy the inequalities for region A.

Task #17: Minimize Cost

You are the assistant manager of an electronics store. Next month you will order two types of tablet PCs. How many of each model (A or B) should you order to minimize your cost?

- Model A: Your cost is \$300 and your profit is \$40.
- Model B: Your cost is \$400 and your profit is \$60.
- You expect a profit of at least \$4,800.
- You expect to sell at least 100 units.

Task #18: Dirt Bike Dilemma**Dirt Bike Dilemma**

NAME _____

The Annual Springfield Dirt Bike Competition is coming up, and participants are looking for bikes! Of course, they turn to Apu, who has the best bikes in town.

Apu has 18 wheels, 15 seats, and 14 exhaust pipes in his supply room. He can use these parts to assemble two different types of bikes: The Rider, or The Rover.

The Rider has 2 wheels, 1 seat, and 2 exhaust pipes. It is designed to glide around curves effortlessly.

The Rover has 3 wheels, 3 seats, and 1 exhaust pipe. It is designed to carry multiple passengers over the roughest terrain.

Apu needs to decide how many of each bike he should assemble to maximize his profit. Because of the popularity of the Dirt Bike Competition, he knows that no matter how many bikes he assembles, he will be able to sell all of them. Apu requests your assistance in making this decision.

Every member of your team should have the following items:

- Graphing Calculator
- Dirt Bike Dilemma Activity Sheet
- Three (3) Colored Pencils
- Set of Cards

In addition, each member of your team should get some cards:

- One member of your team should get 18 Wheel Cards. This person should complete Question 1.
- Another member of your team should get 14 Exhaust Pipe Cards. This person should complete Question 2.
- The last member of your team should get 15 Seat Cards. This person should complete Question 3.

1. Given 18 wheels, list all possible combinations of Riders and Rovers that can be assembled. Remember that each Rider needs two wheels and each Rover needs three wheels. Using only the wheel cards, complete the table. Plot the data on the grid below. (The possible combinations from the first two rows have been plotted for you.)

NUMBER OF RIDERS	POSSIBLE NUMBER OF ROVERS
0	0, 1, 2, 3, 4, 5, 6
1	0, 1, 2, 3, 4, 5
2	
3	
4	
5	
6	
7	
8	
9	

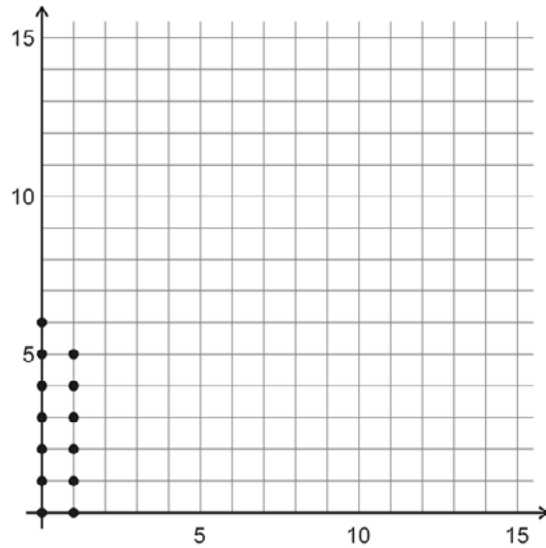

- a. What do you notice about the graph?

- b. On your graph, draw a line that borders all the points. This line should pass through *some* of the points that represent the maximum number of Rovers.

What inequality could be used to represent this relationship? _____
 This inequality is called a *restriction* or a *constraint*.

- c. How can you arrive at this inequality without the use of the table and graph?

2. Given 14 exhaust pipes, list all possible combinations of Riders and Rovers that can be assembled. Remember that each Rider needs two exhaust pipes and each Rover needs one exhaust pipe. Using only the exhaust pipe cards, complete the table. Plot the data on the grid below. (The possible combinations from the first two rows have been plotted for you.)

NUMBER OF RIDERS	POSSIBLE NUMBER OF ROVERS
0	0, 1, 2, ..., 14
1	0, 1, 2, ..., 12
2	
3	
4	
5	
6	
7	

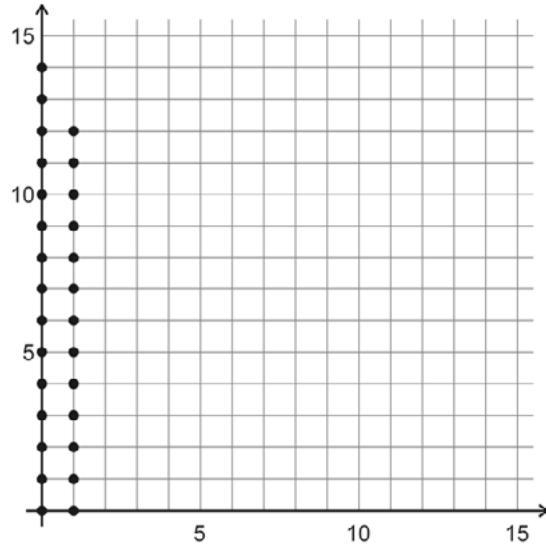

- a. What do you notice about the graph?

- b. On your graph, draw a line that borders all the points. This line should pass through *all* of the points that represent the maximum number of Rovers.

What inequality could be used to represent this relationship? _____
 This inequality is called a *restriction* or a *constraint*.

- c. How can you arrive at this inequality without the use of the table and graph?

3. Given 15 seats, list all possible combinations of Riders and Rovers that can be assembled. Remember that each Rider needs one seat and each Rover needs three seats. Using only the seat cards, complete the table. Plot the data on the grid below. (The possible combinations from the first two rows have been plotted for you.)

NUMBER OF RIDERS	POSSIBLE NUMBER OF ROVERS
0	0, 1, 2, 3, 4, 5
1	0, 1, 2, 3, 4
2	
3	
4	
5	
6	
7	
8	
9	
10	
11	
12	
13	
14	
15	

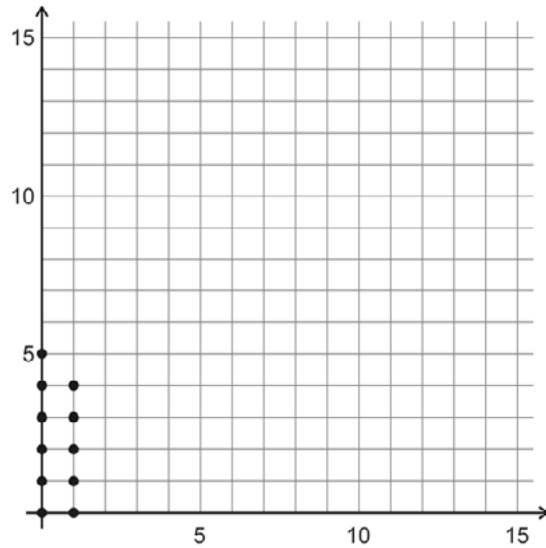

- a. What do you notice about the graph?

- b. On your graph, draw a line that encloses all the points. This line should pass through some of the points that represent the maximum number of Rovers.

What inequality would represent this relationship? _____
 This inequality is called a *restriction* or a *constraint*.

c. How can you arrive at this inequality without the use of the table and graph?

4. Discuss your answers with your team members. Explain how you arrived at your responses. Based on your discussion, complete Questions 1 through 3.

If all of the ordered pairs (Rider, Rover) that are feasible options are identified in the three graphs above, explain why each statement below is true.

a. All ordered pairs have integer coordinates.

b. When graphed in the coordinate plane, all ordered pairs will be located in either the first quadrant or on the positive x -axis or y -axis.

5. Below, list the three inequalities from Questions 1b, 2b, and 3b. Since all feasible ordered pairs (Rider, Rover) must be located either in the first quadrant or on one of the positive axes, what TWO additional inequalities should also be added to this list? Add them below.

6. Put all of your cards together. As a team, using the cards and the information from Questions 1-3, determine all possible combinations of Riders and Rovers that can be assembled with 18 wheels, 15 seats, and 14 exhaust pipes. Remember that each Rider needs 2 wheels, 1 seat, and 2 exhaust pipes, and each Rover needs 3 wheels, 3 seats and 1 exhaust pipe. Complete the table below, and plot your data on the grid.

NUMBER OF RIDERS	POSSIBLE NUMBER OF ROVERS
0	
1	
2	
3	
4	
5	
6	
7	
8	
9	

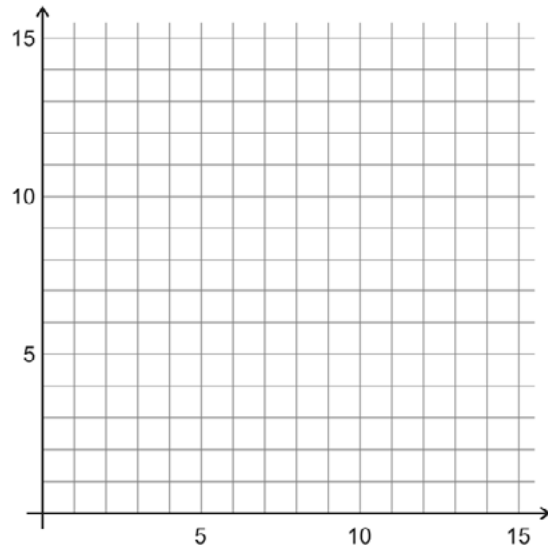

7. Carefully graph all five inequalities from Questions 5 on the grid in Question 6. What do you notice?

The region bounded by these inequalities is called the *feasible region*. The feasible region is the region that satisfies **all** of the constraints.

8. Suppose Apu makes a profit of \$15 for each Rider and \$30 for each Rover. Select two points from the feasible region to determine the total profit that Apu would receive. Show how you arrived at your answers.

a. First point in the feasible region: (_____ , _____)

b. Second point in the feasible region: (_____ , _____)

9. If Apu makes a profit of \$15 on each Rider and \$30 on each Rover, write an expression to represent the total profit he receives. Let x represent the number of Riders he sells, and let y represent the number of Rover he sells.

Total Profit = _____

This function is known as an *objective function*. The objective function is the function that you are trying to maximize or minimize. (In this case, the objective is to maximize Apu’s profit.)

10. Apu makes a profit of \$15 for each Rider and \$30 for each Rover.

a. Find three ordered pairs in which the total profit earned would be \$90, \$120, or \$180. (The points you select do not have to be in the feasible region.)

PROFIT	ORDERED PAIRS		
\$90	(_____ , _____)	(_____ , _____)	(_____ , _____)
\$120	(_____ , _____)	(_____ , _____)	(_____ , _____)
\$180	(_____ , _____)	(_____ , _____)	(_____ , _____)

- b. On the grid below, plot each set of points (those for a total profit of \$90, those for a total profit of \$120, and those for a total profit of \$180) in a different color. Each set of three points should form a straight line. Why does this make sense?

Draw a line through each set of points. What do you notice about these lines? Why does this make sense?

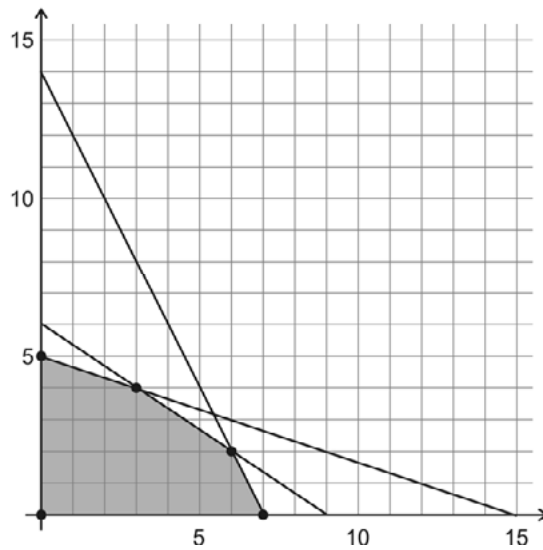

- c. Does one of these values — \$90, \$120, or \$180 — represent the MAXIMUM total profit that Apu can earn if he receives a profit of \$15 for each Rider and \$30 for each Rover? Explain your reasoning.

11. Using the TI-83+ or TI-84+ Graphing Calculator, follow the steps outlined below.

- a. Press **PRGM**. Use the down cursor key to highlight **DRTBK**. Press **ENTER**. Press **STAT**. Press **ENTER**.
- b. Use the up cursor key to highlight **L1**. Press **2nd** **DEL**. Press **2nd** **STAT**. Use the down cursor key to highlight **RIDER**. Press **ENTER** twice. This column represents the number of Riders sold.
- c. Use the right and up cursor key to highlight **L1**. Press **2nd** **DEL**. Press **2nd** **STAT**. Use the down cursor key to highlight **ROVER**. Press **ENTER** twice. This column represents the corresponding number of Rovers sold.
- d. Use the right and up cursor key to highlight **L1**. Press **2nd** **DEL**. Press **2nd** **STAT**. Use the down cursor key to highlight **TPRFT**. Press **ENTER** twice. This column represents the Total Profit received.
- e. Use the right and up cursor key to highlight **L1**. Press **2nd** **DEL**. Press **2nd** **STAT**. Use the down cursor key to highlight **PRFIT**. Press **ENTER** twice. The first number in this column represents the profit earned for each Rider sold and the second number represents the profit earned for each Rover sold.
- f. Use the up cursor key to highlight the number below **PRFIT**. Type in a value for the profit Apu receives for each Rider he assembles. Press **ENTER**. Type in a value for the profit Apu receives for each Rover he assembles. Press **ENTER**.

In **Step f**, enter 15 as the profit for each Rider and 30 as the profit for each Rover. Move the cursor to the **TPRFT** column. Use the cursor key to find the *maximum total profit* (the largest number in this column).

Record this value in the appropriate space in the table below. Along with this value, record the corresponding values for Riders and Rovers. To change the profit earned on each Rider and Rover, move to the **PRFIT** column and repeat **Step f**. Complete the table below choosing your own values for the last several rows.

PROFIT ON EACH RIDER	PROFIT ON EACH ROVER	NUMBER OF RIDERS	NUMBER OF ROVERS	MAXIMUM TOTAL PROFIT
\$15	\$30			
\$20	\$20			
\$10	\$40			

Compare your results with those of your team members. Which combinations of **(Rider, Rover)** always appear?

Where are these points located on your graph in Question 6?

Given all the points in the feasible region, why do you think that just one **(Rider, Rover)** combination always yields the maximum profit?

12. Using your graphing calculator, follow the steps below.

Step 1: Press **APPS**. Press the up cursor key. Use the down cursor key to highlight **TRANSFRM**. Press **ENTER** twice.

Step 2: Press **WINDOW**. Press the up cursor key. Use the down cursor key to highlight step. Type in 5. Press **ENTER**. Press **GRAPH**.

Step 3: Use the up or down cursor key to move to **A**. Enter **15**. Press **ENTER**. **A** represents the profit earned for each Rider. Use the down cursor key to move to **B**. Enter **30**. **B** represents the profit earned for each Rover. Press **ENTER**. Use the down cursor to move to **C**. Type in **0**. Press **ENTER**. **C** represents the total profit earned.

Step 4: Use the right cursor key to increase the value of **C**. Watch the line on your graph.

a. As the line moves, what is the last point in the feasible region through which the line passes?

(_____ , _____)

b. What is the value of **C** at this point? _____

c. Repeat **Steps 3** and **4** for different values of **A** and **B**. As a team, come up with an explanation for why the corner points of the feasible region always yield the maximum (or minimum) profit.



15. Use your steps from Question 14 to solve the problem below.

Lisa is making cookies to sell at the Annual Dirt Bike Competition. A dozen oatmeal cookies require 3 cups of flour and 2 eggs. A dozen sugar cookies require 4 cups of flour and 1 egg. She has 40 cups of flour and 20 eggs. She can make no more than 9 dozen oatmeal cookies and no more than 7 dozen sugar cookies, and she earns \$3 for each dozen oatmeal cookies and \$2 for each dozen sugar cookies. How many dozens of each type of cookie should she make to maximize her profit?

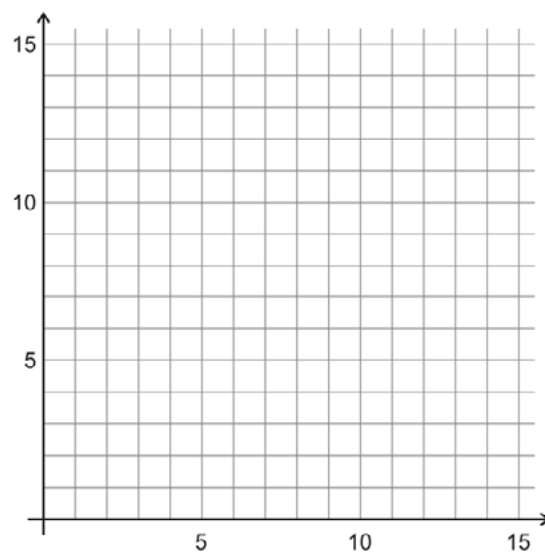

Task #20: Jackson's Party

Jackson is buying wings and hot dogs for a party. Hotdogs cost \$4 per pound and a package of wings costs \$7. He has at most \$56 to spend on meat. Jackson knows that he will buy at least five pounds of hot dogs and at least two packages of wings. List and justify at least two solutions for the number of packages of wings and pounds of hot dogs Jackson could buy.

SREB

SREB Readiness Courses
Transitioning to college and careers

College Readiness Mathematics

Unit 6 . Quadratic Functions
Version 3

Southern
Regional
Education
Board

592 Tenth Street, NW
Atlanta, GA 30318
(404) 875-9211

www.sreb.org

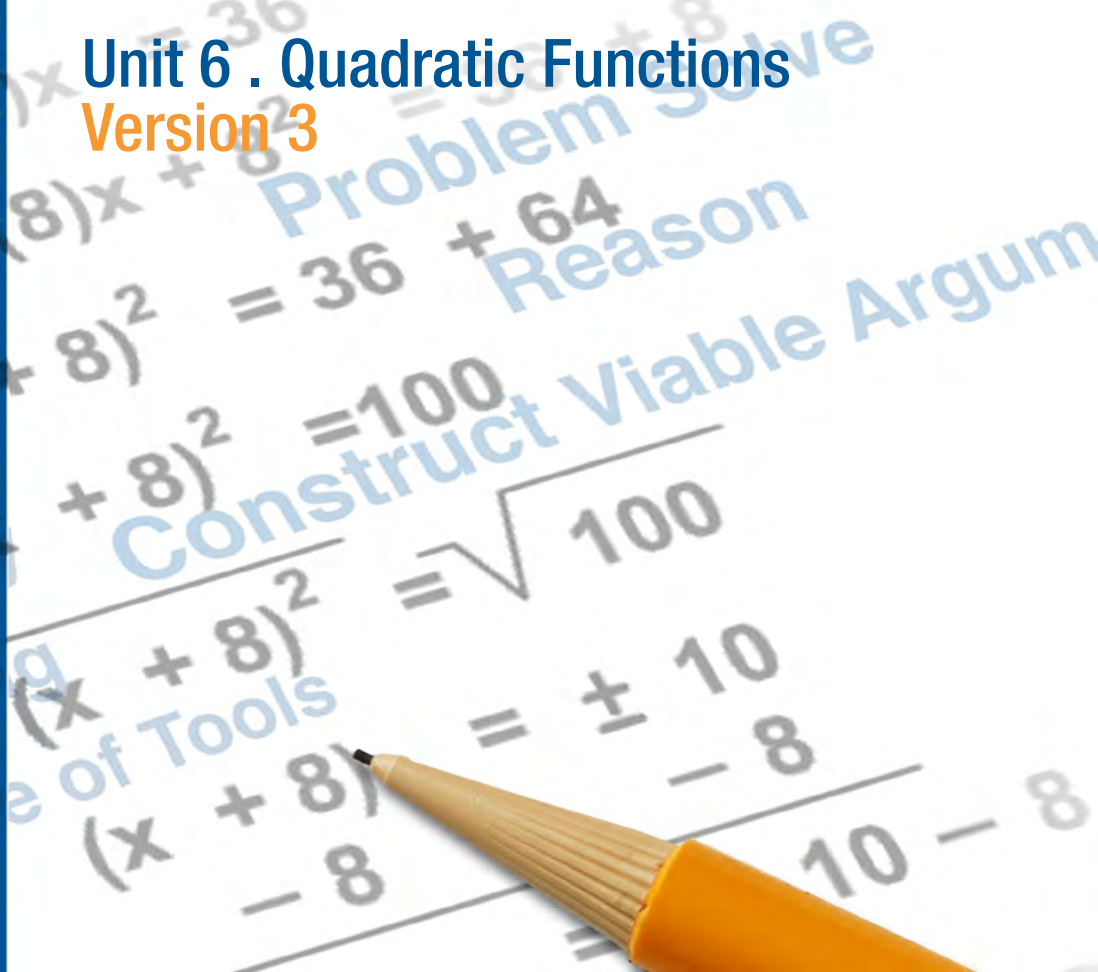

Unit 6 . Quadratic Functions

Overview

Purpose

This unit is an expansive, deeper look at quadratic functions. It draws upon students understanding of quadratic expressions from Unit 1, as well as previously studied quadratic topics in prior course work. Students will explore quadratic functions through application and conceptual problems by focusing on the interplay of multiple representations (equations in various forms, tables, graphs and written expressions). The unit will also extend into general function transformation rules and comparison of quadratic functions to other functions previously studied.

Essential Questions:

When modeling objects that represent quadratic patterns how might we represent the flight path graphically, tabular, with a verbal description and a mathematical equation?

What would change this flight path and how is that reflected in each of the representations?

What might be the benefits of writing quadratic functions in a different but equivalent form?

How can different representations make answering questions and solving quadratic functions more efficient?

How are quadratic functions similar to and different from other functions?

Georgia Standards of Excellence

Seeing Structure in Expressions

Interpret the structure of expressions.

- MGSE9-12.A.SSE.1: Interpret expressions that represent a quantity in terms of its context.
- MGSE9-12.A.SSE.1a: Interpret parts of an expression, such as terms, factors and coefficients, in context.
- MGSE9-12.A.SSE.2: Use the structure of an expression to rewrite it in different equivalent forms. For example, see $x^4 - y^4$ as $(x^2)^2 - (y^2)^2$, thus recognizing it as a difference of squares that can be factored as $(x^2 - y^2)(x^2 + y^2)$.

Write expressions in equivalent forms to solve problems.

- AMGSE9-12.A.SSE.3: Choose and produce an equivalent form of an expression to reveal and explain properties of the quantity represented by the expression.
- MGSE9-12.A.SSE.3a: Factor any quadratic expression to reveal the zeros of the function defined by the expression.
- MGSE9-12.A.SSE.3b: Complete the square in a quadratic expression to reveal the maximum or minimum value of the function defined by the expression.

Creating Equations

Create equations that describe numbers or relationships.

- MGSE9-12.A.CED.1: Create equations and inequalities in one variable and use them to solve problems. Include equations arising from linear, quadratic, simple rational, and exponential functions (integer inputs only).

Reasoning with Equations and Inequalities

Solve equations and inequalities in one variable.

- MGSE9-12.A.REI.4: Solve quadratic equations in one variable.
- MGSE9-12.A.REI.4a: Use the method of completing the square to transform any quadratic equation in x into an equation of the form $(x - p)^2 = q$ that has the same solutions. Derive the quadratic formula from $ax^2 + bx + c = 0$.
- MGSE9-12.A.REI.4b: Solve quadratic equations by inspection (e.g., for $x^2 = 49$), taking square roots, factoring, completing the square, and the quadratic formula, as appropriate to the initial form of the equation (limit to real number solutions).

Solve systems of equations.

- MGSE9-12.A.REI.7: Solve a simple system consisting of a linear equation and a quadratic equation in two variables algebraically and graphically. For example, find the points of intersection between the line $y = -3x$ and the circle $x^2 + y^2 = 3$

Interpreting Functions

Interpret functions that arise in applications in terms of the context.

- MGSE9-12.F.IF.4: Using tables, graphs, and verbal descriptions, interpret the key characteristics of a function which models the relationship between two quantities. Sketch a graph showing key features including: intercepts; interval where the function is increasing, decreasing, positive, or negative; relative maximums and minimums; symmetries; end behavior; and periodicity.

Analyze functions using different representations.

- MGSE9-12.F.IF.7: Graph functions expressed algebraically and show key features of the graph both by hand and by using technology.
- MGSE9-12.F.IF.7a: Graph linear and quadratic functions and show intercepts, maxima and minima (as determined by the function or by context).
- MGSE9-12.F.IF.8: Write a function defined by an expression in different but equivalent forms to reveal and explain different properties of the function.
- MGSE9-12.F.IF.9: Compare properties of two functions each represented in a different way (algebraically, graphically, numerically in tables, or by verbal descriptions). For example, given a graph of one function and an algebraic expression for another, say which has the larger maximum.

Building Functions

Build new functions from existing functions.

- MGSE9-12.F.BF.3: Identify the effect on the graph of replacing $f(x)$ by $f(x) + k$, $k f(x)$, $f(kx)$, and $f(x + k)$ for specific values of k (both positive and negative); find the value of k given the graphs. Experiment with cases and illustrate an explanation of the effects on the graph using technology. Include recognizing even and odd functions from their graphs and algebraic expressions for them.

Prior Scaffolding Knowledge / Skills:

- Students should be comfortable with the Cartesian plan and graphing functions given in both the $y=$ and $f(x)$ form.
- Students should be procedurally fluent in moving between tables, equations, and graphs of the same given function.
- Students should have a solid command of the laws of arithmetic and their connection to algebraic thinking.
- Students should understand how to justify if two expressions are equal and be able to shed light on a problem given two equivalent expressions.
- Students should understand the relationship between zeros and factors of a polynomial.
- Students should be able to create equations, in one and two variable, to represent relationships between quantities; graph equations on coordinate axes with labels and scales.

Lesson Progression Overview:

Lesson Big Idea	Lesson Details	Georgia Standards of Excellence	Standards for Mathematical Practice
Lesson 1: Key Features of Quadratic Graphs	Students begin this lesson by launching projectile motion and modeling the motion. This activity is broad and is meant for engagement; precision to the data collected will occur in lesson 12. Students then look at what is and what is not a parabola and more specifically the characteristics of a parabola.	MGSE9-12.F.IF.4 MGSE9-12.F.IF.7 MGSE9-12.F.IF.7a	SMP 3 SMP 4
Lesson 2: The effect of coefficients on standard form quadratic functions	Students begin this lesson by conceptualizing the projectile motion equation. They first ignore initial velocity, then gravity, and eventually put it all back together. Students then progress into a decontextualized situation and explore with technology the effects, graphically, of manipulating the structure of the coefficients in standard form.	MGSE9-12.A.SSE.1 MGSE9-12.A.CED.1 MGSE9-12.F.IF.7 MGSE9-12.F.IF.7a MGSE9-12.F.IF.9	SMP 1 SMP 2 SMP 5 SMP 8
Lesson 3: Making sense of the structure of the three forms of quadratic functions	This lesson is a modification of a NCTM Illuminations activity. Students use the structure of the three forms of quadratics to answer questions and determine a winner of an egg launch competition. This lesson is meant to be a precursor to the capstone project that revisits the gummy bear launch.	MGSE9-12.A.SSE.1 MGSE9-12.A.SSE.2 MGSE9-12.A.SSE.3 MGSE9-12.F.IF.4 MGSE9-12.F.IF.7 MGSE9-12.F.IF.7a MGSE9-12.F.IF.8 MGSE9-12.A.SSE.1a MGSE9-12.F.IF.9	SMP 3 SMP 7
Lesson 4: Formative Assessment	This formative assessment lesson focuses on students' ability to garnish information from the structure of the forms of quadratics.	MGSE9-12.A.SSE.1 MGSE9-12.F.IF.8 MGSE9-12.F.IF.8a MGSE9-12.F.IF.9	SMP 1 SMP 2 SMP 3
Lesson 5: Same story different equation – Moving between the forms	This lesson focuses on moving between forms by drawing on skills of multiplying and factoring. Students will move from vertex form, but at this point will not be expected to force equations into vertex form as that is the next lesson.	MGSE9-12.A.SSE.1 MGSE9-12.A.SSE.1a MGSE9-12.A.SSE.2 MGSE9-12.A.SSE.3 MGSE9-12.A.SSE.3a MGSE9-12.A.SSE.3b MGSE9-12.A.CED.1 MGSE9-12.F.IF.4 MGSE9-12.F.IF.7 MGSE9-12.F.IF.7a	SMP 1 SMP 3 SMP 7
Lesson 6: Getting to Vertex Form – Completing the Square	Students will use algebra tiles to discover what is meant spatially by “completing the square.” This lesson builds a conceptual understanding of the process of completing the square.	MGSE9-12.A.SSE.1 MGSE9-12.A.SSE.1a MGSE9-12.A.SSE.2 MGSE9-12.A.SSE.3 MGSE9-12.F.IF.4 MGSE9-12.F.IF.7 MGSE9-12.F.IF.7a	SMP 2 SMP 4 SMP 7

Lesson Big Idea	Lesson Details	Georgia Standards of Excellence	Standards for Mathematical Practice
Lesson 7: Transformations and Quadratic Functions	Students use technology to investigate the effects of changing the coefficient k in vertex form to the resulting graph.	MGSE9-12.F.BF.3	SMP 5
Lesson 8: Solving Quadratics	This lesson concentrates on what it “means” to solve a quadratic and explores a graphical and tabular approach first. Students make connections to the terminology of solving, roots, and x -intercepts.	MGSE9-12.A.REI.4 MGSE9-12.A.REI.4a MGSE9-12.A.REI.4b MGSE9-12.F.IF.4 MGSE9-12.F.IF.9	SMP 2 SMP 3 SMP 6
Lesson 9: Solving Quadratics – Comparing Methods	Knowing what to do with the structure of each form of quadratic leads to strategic competence in efficiently solving quadratic equations. This investigation focuses on choosing the most appropriate method.	MGSE9-12.A.REI.4 MGSE9-12.A.REI.4a MGSE9-12.A.REI.4b MGSE9-12.F.IF.4 MGSE9-12.F.IF.9	SMP 1 SMP 3 SMP 6
Lesson 10: Generalizing Solving – The Quadratic formula	The quadratic formula is a way to express repeated reasoning of solving quadratics in vertex form. Students explore this pattern and arrive at the quadratic formula.	MGSE9-12.A.SSE.2 MGSE9-12.A.REI.4 MGSE9-12.A.REI.4a MGSE9-12.A.REI.4b	SMP 1 SMP 8
Lesson 11: Systems of Equations with Quadratics	This lesson provides an extension and connection from the systems unit already studied. Students look at systems of a line and parabola and two parabolas.	MGSE9-12.A.REI.7 MGSE9-12.F.IF.4 MGSE9-12.F.IF.7 MGSE9-12.F.IF.7a MGSE9-12.F.IF.9	SMP 1 SMP 3
Lesson 12: Capstone Project(s)	This is a comprehensive project that addresses all quadratic function and algebra standards in this unit as students are asked to return to the gummy bear launch. This time, however, the focus is on precision and modeling techniques in order for the class to arrive at one winner. Students will be given time to collect data and alter strategies before the class selects a unique winner.	All standards addressed in this unit.	SMP 1 SMP 4 SMP 5 SMP 6

Quadratic Functions

Lesson 1 of 12

Key Features of the Quadratic Graph

Description:

Students begin this lesson by launching projectile motion and modeling the motion. This activity is broad and is meant for engagement; precision to the data collected will occur in lesson 12. Students then look at what is and what is not a parabola and more specifically the characteristics of a parabola.

Georgia Standards of Excellence Addressed:

- MGSE9-12.F.IF.4: Using tables, graphs, and verbal descriptions, interpret the key characteristics of a function which models the relationship between two quantities. Sketch a graph showing key features including: intercepts; interval where the function is increasing, decreasing, positive, or negative; relative maximums and minimums; symmetries; end behavior; and periodicity.
- MGSE9-12.F.IF.7: Graph functions expressed algebraically and show key features of the graph both by hand and by using technology.
- MGSE9-12.F.IF.7a: Graph linear and quadratic functions and show intercepts, maxima and minima (as determined by the function or by context).

Standard(s) for Mathematical Practice Emphasized:

- SMP 3: Construct viable arguments and critique the reasoning of others.
- SMP 4: Model with mathematics.

Sequence of
Instruction

Activities Checklist

Engage

MATH
4
PRACTICE

Entry Event: Students should be assigned to cooperative groups of four for this activity. The following jobs are possible individual roles for group members. Job descriptor cards are provided as a resource.

- Recording Time Keeper
- Reading Manager
- Spying Monitor
- Quality Controller

Students should have access to the following supplies: tongue depressors, gummy bears, rubber bands, index cards, chart paper and markers. Each group should have their own set of supplies. Directions are purposefully not given.

As a class, briefly discuss the popular game Angry Birds. Students will recognize this context; ask the students to tell you what they know about Angry Birds. It may be helpful to show a few games, screen shots or display a round of Angry Birds. (There are some screen shots, but more are available online.)



Without further explanation, give the students the following directions:

Model the flight of an angry bird using the tools provided. In your group, decide what the key features of this model are and label your poster accordingly. You do NOT have to attend to precision with the location of the points but you should include a brief description and how you COULD find these precise values. All information should be recorded on a group poster. Additionally, what are three questions your group has? Record these on your poster.

It may be helpful to show students how to construct a firing apparatus by joining two tongue depressors together with a pencil (or some other small device) between the depressors to serve as a fulcrum. Wrap a rubber band tightly to the end where the depressors and pencil meet in order that one end opens wider than the other. By placing a gummy bear on the wider opening, the bears will “launch.”

After students have constructed and displayed their models on a poster, discuss the variety of “models” shown. This activity is not meant to be precise but rather to get students thinking about key features of a quadratic pattern using real data. The following questions may be helpful in facilitating class discourse of modeling the flight of an angry bird:

1. What do you notice about the flight of your gummy bear? Explain – perhaps “air” draw a picture of what you think this looks like?
2. When we look at the flight path of the gummy bear, what are some important data points to look at, or to know? Why? Justify your choice.
3. What factors influence the flight of our gummy bear?
4. If we held a competition for the gummy bear that goes the highest, what would we need to know?
5. If we held a competition for the gummy bear that travels the furthest, what would we need to know?
6. If we held a competition for the gummy bear that was in the air the longest, what would we need to know?
7. Would any of the competitions mentioned above have the same winners? Why or why not?

Explore

INCLUDED IN THE STUDENT MANUAL

Task #1: Quadratic or Not?

In your groups, use the illustration to help you in defining key features of quadratic graphs. Prepare a toolkit to share with the class.

1. The following are graphs of quadratic functions:

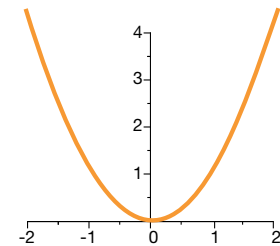
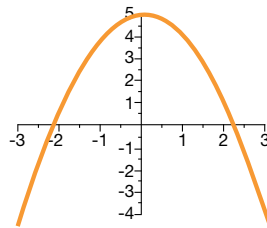
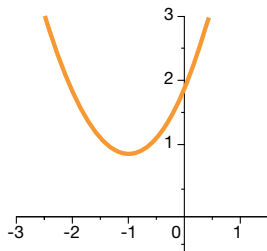

2. The following are not graphs of quadratic functions:

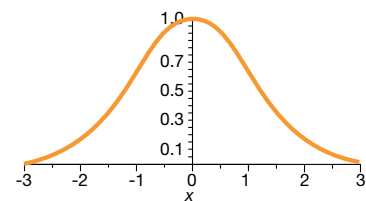
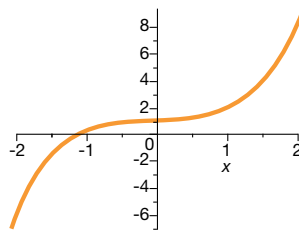
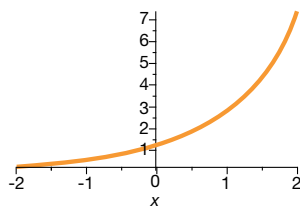

Describe how quadratics differ from functions that are not quadratics. Describe any symmetries that you see, asymptotes, the domain, range, how it is decreasing or increasing, concavity.

Possible Solutions:

The graphs of quadratic functions have varying rates of change unlike linear functions that have a constant rate of change. Quadratic functions appear to increase at a decreasing rate then decrease at a decreasing rate OR decrease at a decreasing rate and then increase at a decreasing rate. There is a change in direction that can be seen in the table as well as the graph. The given graphs of non-quadratic functions do not show this, except for the last one which shows some of the same characteristics but it has yet another factor; this graph does not continue to decrease or increase like a parabola does.

The graphs of quadratics, or parabolas, are symmetrical about the axis of symmetry, or the x-value of the vertex. They have a limited range as they will not extend on in one direction but have a domain of all real numbers. Parabolas can be both concave up and down and have no asymptotes as they do not approach anything in the long run.

Explanation



In the explore activity, students are asked to define key features of quadratic graphs from decontextualize situations. Purposefully select groups to share their toolkit entries making sure all key features (symmetries, intercepts, increasing/decreasing, concavity, and domain/range) are discussed and recorded on the students' toolkit. Possible solutions are given but are not the only solutions to share. The following are suggested discussion prompts for class discourse:

1. What makes a quadratic graph different from the graphs of other functions?
2. What key features are similar to other types of functions?
3. What is unique about a quadratic function's rate of change?
4. What is the domain for a quadratic function? Will this work for all quadratic functions? Why or why not?
5. What is the range for a quadratic function? Will this work for all quadratic functions? Why or why not?

Evaluate Understanding

Each group of students should be given one of the following terms to define and draw a picture. These should comprise a “word wall” for this unit.

Terms: parabola, maximum/minimum, vertex, zeros (and synonyms), quadratic.

Closing Activity

Students should draw a picture of a quadratic function graphically and NOT a quadratic function and explain the differences between the two. In addition, on the quadratic function students should label key points.

Pose the following question: Using your picture of a quadratic function, what do you expect the table of this function to look like? Justify your answer.

Independent Practice:

Using the internet as a resource, students should find pictures of parabolas in “real life” and label vocabulary words on the pictures.

Resources/Instructional Materials Needed:

- Tongue depressors
- Gummy bears
- Rubber bands
- Index cards
- Chart paper
- Markers

Notes:

Quadratic Functions

Job Descriptor Cards

Reading Manager

- Reads ALL parts of the assignment and problems out loud to the group (others follow along).
- Ensures group members understand assignments.
- Keeps group focused on the task(s).

Spying Monitor

- Monitors group progress relative to other groups.
- Checks in with other groups for comparison.
- Only member in group that can talk/ask questions outside of group.

Quality Controller

- Ensures that all group members can EXPLAIN and JUSTIFY each response (random checks occur by management).
- Makes sure members are completing ALL problems in appropriate notebook.
- Keeps group supplies organized and neat.
- Reports missing items.

Recording Time Keeper

- Keeps track of time.
- When asked, shares group responses.
- Responsible for ensuring “public record” (posting of answers, group posters, etc.) is completed.

Quadratic Functions

Lesson 2 of 12

The Effects of the Coefficients on Standard Form Quadratic Functions

Description:

Students begin this lesson by conceptualizing the projectile motion equation. They first ignore initial velocity, then gravity, and eventually put it all back together. Students then progress into a decontextualized situation and explore with technology the effects, graphically, of manipulating the structure of the coefficients in standard form.

Georgia Standards of Excellence Addressed:

- MGSE9-12.A.SSE.1: Interpret expressions that represent a quantity in terms of its context.
- MGSE9-12.A.CED.1: Create equations and inequalities in one variable and use them to solve problems. Include equations arising from linear, quadratic, simple rational, and exponential functions (integer inputs only).
- MGSE9-12.F.IF.7: Graph functions expressed algebraically and show key features of the graph both by hand and by using technology.
- MGSE9-12.F.IF.7a: Graph linear and quadratic functions and show intercepts, maxima and minima (as determined by the function or by context).
- MGSE9-12.F.IF.9: Compare properties of two functions each represented in a different way (algebraically, graphically, numerically in tables, or by verbal descriptions). For example, given a graph of one function and an algebraic expression for another, say which has the larger maximum.

Standard(s) for Mathematical Practice Emphasized:

- SMP 1: Make sense of problems and persevere in solving them.
- SMP 2: Reason abstractly and quantitatively.
- SMP 5: Use appropriate tools strategically.
- SMP 8: Look for and express regularity in repeated reasoning..

Sequence of Instruction

Activities Checklist

Engage



Begin class with discussion of what happens to objects in free-fall. For the purpose of “clean science” neglect air resistance. The following questions could be used as discussion prompts. Suggested answers are in parenthesis.

- If I drop a watermelon off the top of my roof, what happens? (It drops straight down.)
- Why does the watermelon travel downward? (Gravity pulls all objects towards the center of the earth or more simply the ground.)
- Does anyone know what the acceleration due to gravity is? (9.8m/s² or 32ft/s² toward the center of the earth. The laws of Calculus and Physics interact to give us the equation distance fallen is $(\frac{1}{2})gt^2$.)
- In trying to figure out “gravity,” Galileo performed many experiments with objects at rest put into free-fall (that is simply dropping a watermelon versus throwing the watermelon). For this reason Galileo is credited with “discovering gravity.” The equation $d = -16t^2$ models the distance an object has fallen for time t .
- Suppose I am standing on a roof 60 feet above the ground and I simply drop a watermelon. In your groups make a table showing how far the watermelon has dropped at times 0.25, 0.5, 0.75, 1, 1.25, 1.5, 1.75, 2.0 and 2.25 seconds. Which of these values do not make sense? Why? Make another table that shows how far above the ground my watermelon is at the appropriate times.

Answers:

Time(s)	Distance Fallen	Watermelon Height above ground
0.25	1	59
0.50	4	56
0.75	9	51
1	16	44
1.25	25	35
1.50	36	24
1.75	49	11
2	64	-4
2.25	81	-21
t	$-16t^2$	$-16t^2 + 60$

Now, what if we lived in a world without gravity (or we lived in outer space) and we threw an object or launched an angry bird (or gummy bear) – what would happen? (Without gravity, objects would continue on a linear path out of the universe.)

- Suppose I launched an object from 15 feet off the ground at an initial velocity of five ft/s and that there was no gravity. In your groups, make a table of values that shows my objects position at times $t = 0$ to $t = 100$ seconds. (Encourage students to first make sense of this problem before setting up a table from 0 to 100 by increments of one; skip counting will be more appropriate and time efficient.)

- What does your table show? Does this make sense why or why not?

Time(s)	Position
0	15
1	20
2	25
...	...
10	65
20	115
...	...
100	515

Now back to earth. Suppose I still am firing an object at five ft/sec with a starting height of 15. What effect does “earth” have on this object? (Gravity effects the object; gravity pulls the object down to earth rather than continuing to increase.)

What would be my “new” equation that shows all the pieces? ($-16t^2 + v_0t + h_0$ or $-16t^2 +$ initial velocity (time) + starting height)

How are these pieces shown individually and then collaboratively in the equation, in the graph?

Through this engaging scenario, students have just reasoned abstractly and quantitatively to conceptualize the equation for projectile motion or $h(t) = -16t^2 + v_0t + h_0$. The remainder of this investigation leaves the projectile motion equation and focuses on what the coefficients mean in the form $ax^2 + bx + c = y$.

Development of the projectile equation adapted from Contemporary Mathematics in Context: Core Plus Course 3 published by McGraw Hill.

Explore



Each group should do all of the function work on the worksheet but become an “expert” on one set in order to explain their discovery to the class.

As students look at the sets of functions, they should use technology appropriately to look for and express with repeated regularity in the functions and thus generalize a pattern.

**It may be helpful to use an online graphing tool that includes “sliders.” Some options include shodor.org or desmos.com.*

INCLUDED IN THE STUDENT MANUAL

Task #2: The effect of a, b, and c

Answer the following equations for each function set. Each function set has four equations to explore.

Function Set 1

Equation 1: $f(x) = x^2 + 2x - 3$

Equation 2: $f(x) = -x^2 + 2x - 3$

Equation 3: $f(x) = 3x^2 + 2x - 3$

Equation 4: $f(x) = -3x^2 + 2x - 3$

What is different between equations 1 and 2?

What is different between equations 1 and 3?

What is different between equations 2 and 4?

What is different between equations 3 and 4?

What is the domain of the first function?

What is the domain of the second function?

What is the domain of the third function?

What is the domain of the fourth function?

Function Set 2

Equation 1: $f(x) = x^2 + 2x - 3$

Equation 2: $f(x) = -x^2 + 2x + 3$

Equation 3: $f(x) = x^2 + 2x + 3$

Equation 4: $f(x) = -x^2 + 2x - 3$

What is different between equations 1 and 2?

What is different between equations 1 and 3?

What is different between equations 2 and 4?

What is different between equations 3 and 4?

What is the domain of the first function?

What is the domain of the second function?

What is the domain of the third function?

What is the domain of the fourth function?

Function Set 3

Equation 1: $f(x) = x^2 + 2x - 3$

Equation 2: $f(x) = x^2 - 2x - 3$

Equation 3: $f(x) = 3x^2 + 2x - 3$

Equation 4: $f(x) = 3x^2 - 2x - 3$

What is different between equations 1 and 2?

What is different between equations 1 and 3?

What is different between equations 2 and 4?

What is different between equations 3 and 4?

What is the domain of the first function?

What is the domain of the second function?

What is the domain of the third function?

What is the domain of the fourth function?

Function Set 4

Equation 1: $f(x) = x^2 + 2x - 3$

Equation 2: $f(x) = 5x^2 + 2x + 5$

Equation 3: $f(x) = 3x^2 + 2x - 3$

Equation 4: $f(x) = -9x^2 + 2x + 4$

What is different between equations 1 and 2?

What is different between equations 1 and 3?

What is different between equations 2 and 4?

What is different between equations 3 and 4?

What is the domain of the first function?

What is the domain of the second function?

What is the domain of the third function?

What is the domain of the fourth function?

Set of Functions Worksheet: Possible Solutions

Function Set 1

Equation 1: $f(x) = x^2 + 2x - 3$ Equation 2: $f(x) = -x^2 + 2x - 3$

Equation 3: $f(x) = 3x^2 + 2x - 3$ Equation 4: $f(x) = -3x^2 + 2x - 3$

What is different between equations 1 and 2?

The graph of equation 1 is concave up, the graph of function 2 is concave down. The “a” value is positive in equation 1 and negative in equation 2

What is different between equations 1 and 3?

The graph of equation 1 is narrower than the graph of equation 3. The “a” value is greater in equation 3 than in equation 1.

What is different between equations 2 and 4?

The graph of equation 4 is narrower than the graph of equation 2. The “a” value has greater magnitude (or absolute value) in equation 4 than that of equation 2.

What is different between equations 3 and 4?

The graph of equation 3 is concave up, the graph of function 4 is concave down. The “a” value is positive in equation 3 and negative in equation 4.

What is the domain of the first function?

What is the domain of the second function?

What is the domain of the third function?

What is the domain of the fourth function?

The domain for all four functions is all real numbers (this is true for Function set 2, 3 and 4).

Function Set 2

Equation 1: $f(x) = x^2 + 2x - 3$ Equation 2: $f(x) = -x^2 + 2x + 3$

Equation 3: $f(x) = x^2 + 2x + 3$ Equation 4: $f(x) = -x^2 + 2x - 3$

What is different between equations 1 and 2?

The graph of equation 1 is concave up, the graph of equation 2 is concave down. Equation 1 has a y-intercept at -3 while equation two has a y-intercept at 3. The “a” value is positive for equation 1 and negative for equation 2. The “c” value is -3 for equation 1 and +3 for equation 2.

What is different between equations 1 and 3?

The graph of equation 3 is 6 units above the graph of equation 1 as the y-intercepts are 6 units apart. The y-intercept of equation 1 is at (0,-3); the y-intercept of equation 3 is at (0, 3). The “c” value is -3 in equation 1 and +3 in equation 3.

What is different between equations 2 and 4?

The graph of equation 2 is 6 units above the graph of equation 4 as the y-intercepts are 6 units apart. The y-intercept of equation 4 is at (0,-3); the y-intercept of equation 2 is at (0, 3). The “c” value is +3 in equation 2 and -3 in equation 4.

What is different between equations 3 and 4?

The graph of equation 3 is concave up, the graph of equation 4 is concave down. Equation 3 has a y-intercept at -3 while equation 4 has a y-intercept at 3. The “a” value is positive in equation 3 and negative in equation 4. The “c” value is -3 in equation 3 and +3 in equation 4.

Set of Functions Worksheet: Possible Solutions

Function Set 3

Equation 1: $f(x) = x^2 + 2x - 3$ Equation 2: $f(x) = x^2 - 2x - 3$

Equation 3: $f(x) = 3x^2 + 2x - 3$ Equation 4: $f(x) = 3x^2 - 2x - 3$

What is different between equations 1 and 2?

The graph of equation 2 is shifted to the right of equation 1. The graphs are reflected over the y-axis. The “b” value of equation 1 is +2 and is -2 for equation 2.

What is different between equations 1 and 3?

The graph of equation 3 is narrower than the graph of equation 1. The “a” value is 1 for equation 1 and 3 for equation 3.

What is different between equations 2 and 4?

The graph of equation 4 is narrower than the graph of equation 2. The “a” value for equation 2 is 1 while the it is 3 for equation 4.

What is different between equations 3 and 4? **The graphs both have the same y-intercept but the graph of equation 4 is narrower and inside of the graph of equation 3.**

Function Set 4

Equation 1: $f(x) = x^2 + 2x - 3$ Equation 2: $f(x) = 5x^2 + 2x + 5$

Equation 3: $f(x) = 3x^2 + 2x - 3$ Equation 4: $f(x) = -9x^2 + 2x + 4$

What is different between equations 1 and 2?

The graph of equation 2 is narrower than the graph of equation 1. The “a” value is larger for equation 2. The y-intercepts are different for the two functions; equation 1 has a y-intercept of (0,-3) and equation 2 has a y-intercept of (0,5). This is seen in the different values of “c.”

What is different between equations 1 and 3?

The graph of equation 3 is narrower than the graph of equation 1. The “a” value is larger for function 3.

What is different between equations 2 and 4?

The graph of equation 2 is concave up, has a y-intercept at (0,5) and is wider than the graph of equation 4 as the “a” value is less than equation 4’s.

The graph of equation 4 is concave down, has a y-intercept at (0,4) and is narrower than the graph of equation 2.

What is different between equations 3 and 4?

The graph of equation 3 is concave up and has a y-intercept at (0,-3). The graph of equation 4 is concave down, narrower than equation 3, and has a y-intercept at (0,4).

Explanation

The students should explain their findings from the exploration with your assistance in probing questions. Possible solutions are included. The intent of the lesson is to understand and predict the change of a graph by evaluating the change in a and c for quadratics in the form $ax^2 + bx + c = y$. The effect of b is not necessarily a key player in this lesson.

Students should also be comfortable with domain values for quadratic functions.

Practice Together / in Small Groups / Individually

Additional practice could include various sets of functions and students should record verbal descriptions of the change from graph of one or two.

Evaluate Understanding



As students work in groups, monitor group explorations. A quick, initial-reaction problem could be posed by simply asking for the differences between the two graphs given and for the domain and range of each function. This should be completed individually but could employ the use of small whiteboards for a quick assessment.

$$\text{Set 1: } f(x) = x^2 + 3x - 5 \text{ and } g(x) = -3x^2 + 3x - 5$$

$$\text{Set 2: } f(x) = 4x^2 - 3x + 10 \text{ and } g(x) = 4x^2 - 3x - 15$$

Possible Solutions:

Set 1: The graph of $f(x)$ is concave up and wider than the graph of $g(x)$. The graph of $g(x)$ is concave down and is narrower (or decreases more rapidly than $f(x)$ increases) as indicated by the magnitude of the “ a ” value.

Set 2: The graph of $f(x)$ and $g(x)$ are congruent parabolas that have been shifted. They sit 25 units apart as the y -intercept of $f(x)$ is at $(0, 10)$, and the y -intercept of $g(x)$ is at $(0, -15)$.

Closing Activity



In the projectile equation, what does -16 represent, what does five represent (in our example) and what does 15 represent. Which of these values are “free” to change? Which is not? What effect on the graph will changing those values that are able to change have on the motion of a projectile?

Possible Solutions: Negative 16 is the constant due to gravity, this is a constant and there is nothing we can do to change this on Earth. Five is the initial velocity. We could increase or decrease our initial velocity in a variety of ways with mechanical devices. If we increased the initial velocity we would see our graph increase quicker, if we decreased the initial velocity we would see the height of the object take longer to reach its maximum. Fifteen is the starting height. This could be changed and will affect the maximum height reached by an object.

Depending on the interest and level of the class, this question should be answered either in groups and a group answer presented or as individual exit tickets. Perhaps if the class is continuing to struggle with the effects of the coefficients on the parabola, discuss the question as a class.

Quadratic Functions

Lesson 3 of 12

Making Sense of the Structure of the Three Forms of Quadratic Functions

Description:

This lesson is a modification of a NCTM Illuminations activity. Students use the structure of the three forms of quadratics to answer questions and determine a winner of an egg launch competition. This lesson is meant to be a precursor to the capstone project that revisits the gummy bear launch.

Georgia Standards of Excellence Addressed:

- MGSE9-12.A.SSE.1: Interpret expressions that represent a quantity in terms of its context.
- MGSE9-12.A.SSE.2: Use the structure of an expression to rewrite it in different equivalent forms. For example, see $x^4 - y^4$ as $(x^2)^2 - (y^2)^2$, thus recognizing it as a difference of squares that can be factored as $(x^2 - y^2)(x^2 + y^2)$.
- MGSE9-12.A.SSE.3: Choose and produce an equivalent form of an expression to reveal and explain properties of the quantity represented by the expression.
- MGSE9-12.A.SSE.3a: Factor any quadratic expression to reveal the zeros of the function defined by the expression.
- MGSE9-12.A.SSE.3b: Complete the square in a quadratic expression to reveal the maximum or minimum value of the function defined by the expression.
- MGSE9-12.F.IF.4: Using tables, graphs, and verbal descriptions, interpret the key characteristics of a function which models the relationship between two quantities. Sketch a graph showing key features including: intercepts; interval where the function is increasing, decreasing, positive, or negative; relative maximums and minimums; symmetries; end behavior; and periodicity.
- MGSE9-12.F.IF.7: Graph functions expressed algebraically and show key features of the graph both by hand and by using technology.
- MGSE9-12.F.IF.7a: Graph linear and quadratic functions and show intercepts, maxima and minima (as determined by the function or by context).
- MGSE9-12.F.IF.8: Write a function defined by an expression in different but equivalent forms to reveal and explain different properties of the function.
- MGSE9-12.F.IF.8a: Use the process of factoring and completing the square in a quadratic function to show zeros, extreme values and symmetry of the graph, and interpret these in terms of a context. For example, compare and contrast quadratic functions in standard, vertex and intercept forms.
- MGSE9-12.F.IF.9: Compare properties of two functions each represented in a different way (algebraically, graphically, numerically in tables, or by verbal descriptions). For

example, given a graph of one function and an algebraic expression for another, say which has the larger maximum.

Standard(s) for Mathematical Practice Emphasized:

- SMP 3: Construct viable arguments and critique the reasoning of others.
- SMP 7: Look for and make use of structure.

Sequence of Instruction <small>Engage/Explore</small>	Activities Checklist
---	-----------------------------

Prior to this lesson students should be comfortable with the idea of plugging in a point to find an unknown. For example, students should be able to find the value of a in the equation $a(x - 4)(x + 2) = y$ when they know that $(3, 10)$ exist on the graph.

For example:

$$a(3 - 4)(3 + 2) = 10$$

$$a(-1)(5) = 10$$

$$a = -2$$

Therefore the exact parabola is $y = -2(x - 4)(x + 2)$

The purpose of this lesson is to draw on previous studies of the three forms of quadratics and to begin using the structure of these forms to derive equations given certain information. In following lessons (4 and 5) students will become more proficient

INCLUDED IN THE STUDENT MANUAL

Task #3 Egg Launch Contest

Egg Launch Contest

NAME: _____

DATE: _____

Mr. Rhodes' class is holding an egg launching contest on the football field. Teams of students have built catapults that will hurl an egg down the field. Ms. Monroe's class will judge the contest. They have various tools and ideas for measuring each launch and how to determine which team wins.

Team A used their catapult and hurled an egg down the football field. Students used a motion detector to collect data while the egg was in the air. They came up with the table of data below.

DISTANCE FROM THE GOAL LINE (IN FEET)	HEIGHT (IN FEET)
7	19
12	90
14	101
19	90
21	55
24	0

Team B's egg flew through the air and landed down the field. The group of students tracking the path of the egg determined that the equation $y = -0.8x^2 + 19x - 40$ represents the path the egg took through the air, where x is the distance from the goal line and y is the height of the egg from the ground. (Both measures are in feet.)

When **Team C** launched an egg with their catapult, some of the judges found that the graph to the right shows the path of the egg.

Which team do you think won the contest? Why?

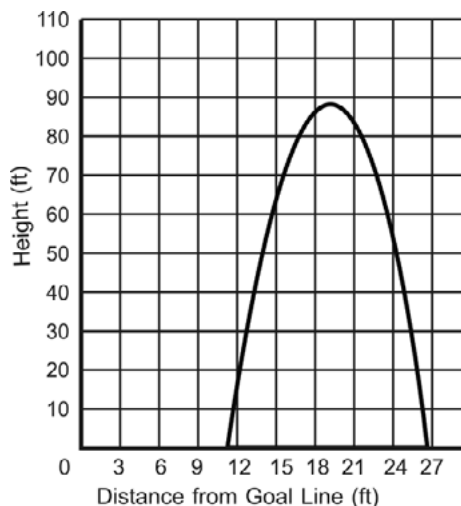

moving between forms to garnish information.

The following directions are adapted from this site:

- Have students read the first two paragraphs (intro and team A) on the activity sheet. Ask the following discussion prompting questions:
 1. What do you notice about the height of the egg as the distance from the starting line increases?
 2. Without graphing, predict the shape of the graph based off of data tables.
- Have students read team B and ask students to describe the shape of the equation.
- Have students read team C. Ask students what they know about the flight path of Team C's egg based off of the graph.
- Instruct students, individually, to make a prediction on who won the competition. Students should be given two to three minutes and expected to write a prediction with reasoning based off the discussion.

Briefly review the three forms of a quadratic that students have studied in previous courses using the following as a guide. (Do NOT talk about moving between the forms, if students do this don't stop them but moving between forms is covered in a later lesson.)

Teacher Write (**in bold**) /Discuss (*in italics*) briefly for all students:

Standard Form: $ax^2 + bx + c = y$ – where a , b , and c are coefficients.

Factored Form: $a(x - r_1)(x - r_2) = y$ – where r_1 and r_2 are x -intercepts. Draw upon Unit 1 methods in recalling that the sign is opposite.

Vertex Form: $a(x - h)^2 + k = y$ – where the vertex of the parabola is (h, k) . Again, use similar reasoning from factored form to realize the sign is opposite with the x -variable.

- Have students work in groups to construct a viable argument for who they believe is the winner of the Egg Launch Competition. This argument will be shared with the

INCLUDED IN THE STUDENT MANUAL

Task #4: Tell an Egg-celent Story



© 2008 National Council of Teachers of Mathematics
<http://illuminations.nctm.org>

class. The use of Tell an Egg-cellent Story Task (Task #4) should be used for students to show their thinking.

While finding equations is not the only route for determining the mathematical winner, if students try to find an equation encourage them to use the structure one of the three forms of quadratics along with the information provided in the team's data report to produce the equations.

Students should grapple in groups with what information they have and what form would be most helpful. Encourage students to be creative in thinking approaches and find ways to evaluate the usefulness and correctness of their hypothesized solutions rather than directing their thinking.

Possible equation solutions:

Team A:

Using the table, notice that the vertex occurs between (12, 90) and (19, 90). Looking at a scatterplot of the data points given, the vertex values appears to fall around 15.5 with a maximum height of 101. Using this information and the vertex form the following calculations were made:

$$y = a(x - 15.5)^2 + 105$$

Any point in the table can be used, this example uses (24,0) to find the value of a. Thus,

$$0 = a(24 - 15.5)^2 + 105$$

$$\text{yielding } a = -1.45$$

And therefore $y = -1.45(x - 15.5)^2 + 105$ is the equation for Team A.

Team B's equation is given in standard form in the handout.

Team C:

From the graph, the x-intercepts appear to be at (11.5, 0) and (26.5, 0). Additionally, the point (12, 15) appears to lie on the parabola. Using this information the following equation can be used:

$$y = a(x - 11.5)(x - 26.5)$$

$$15 = a(12 - 11.5)(12 - 26.5)$$

$$a = -2.06$$

Therefore, Team C has the equation $y = -2.06(x - 11.5)(x - 26.5)$.

These answers will vary as they are arrived at from graphical estimations. Students may use different coordinate values and arrive at different numerical answers.

After students have had time to construct a group argument, select and sequence the groups to present. Start by asking the group with the most simplistic approach (perhaps they graphed all three using points and connected the dots to form a parabola) to go first. The group who has the most complex solution should go last. Students should be encouraged to critique the reasoning of others in the presentations by asking questions and comparing methods. The following questions are suggested questions to help reveal student thinking and may be used to spark discussions.

How many points did it take to find the complete equation? Why is this so?

Was it easy to write all three forms? Explain.

Explain the different strategies that could be used to find the maximum height of the egg. Which is the most efficient?

What group used the structure of the forms of quadratics to help write an equation? Did another group use the same information in a different way? Could you have used another equation?

In addition, the class should come to a conclusion based on the winner of the competition for height and the winner for distance.

For groups that are ready to move on, they should proceed to the activity titled *Three Forms of Quadratic Functions*. For groups that need more work with interpreting graphs and producing equations, an additional handout is provided of three different egg launch graphical scenarios. Students should tell a complete story of these scenarios and add structure to the scenarios (axes) in order to construct equations. This additional information should be used as you gauge the understanding of your class through class discussion.

Practice Together / in Small Groups / Individually

Students should complete *Three Forms of Quadratic Functions* in small groups. This worksheet focuses using the structure of the forms of a quadratic equation and given information to write equations based on:

1. Projectile Motion Equations where v_0 is known.
2. Knowing x-intercepts.
3. Knowing y-intercepts and one root.

INCLUDED IN THE STUDENT MANUAL

Task #5: Three Forms of Quadratic Functions and Making Sense of the Forms

Often times the standard form of a quadratic is used in projectile motion. For this particular situation, the equation $h(t) = -\frac{1}{2}gt^2 + v_0t + h_0$ gives the height of an object at time t for an object that has initial velocity, v_0 and initial height of h_0 . “ g ” is a gravitational constant and is either 9.8m/s^2 or 32ft/s^2 . Often times a simpler form of the equations look like:

For Meters - $h(t) = -9.8t^2 + v_0t + h_0$ For Feet - $h(t) = -16t^2 + v_0t + h_0$

1. A piece of paper and a hammer are dropped off the top of your school which is 90 feet high. They are both dropped from a still position (that is $v_0=0$ for both). If we ignore air resistance, which object, the paper or hammer, hits the ground first? Provide a mathematical argument that starts by sketching a picture of the graph and concludes with an analysis of the equation.
2. A potato is fired from a spud-gun at a height of 3m and an initial velocity of 25m/s, write the equation of this potato projectile. How high does the potato reach and at what time does this occur?
3. Two competing catapults launch pumpkins. Catapult A launches from a starting height of 10ft and an initial upward velocity of 45ft/sec. Catapult B launches from a starting height of 25ft and an initial upward velocity of 40ft/sec. Which pumpkin, A or B, achieves a greater maximum height? Which pumpkin, A or B, is in the air longer? Is it possible from this scenario to determine the distance traveled horizontally by each pumpkin? Explain your choices and justify your answers.

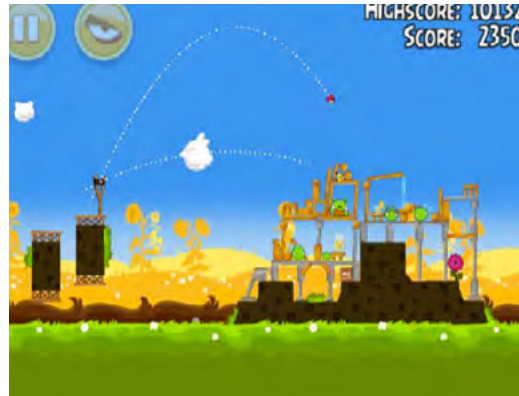

4. The Angry Birds Screen shot shows two flight paths of two different birds. Using a straight edge, construct a coordinate axes where the center of the slingshot is at the origin. Carefully assign point values to the two parabolas and write an equation for each. Show which points you used and which form of the equation you found most helpful. Using mathematical analysis and your equations do the two birds hit at the same spot? Why or why not?
5. The points used to model a parabola are $(-3, 0)$, $(6, 0)$ and $(4, -5)$. Write an equation for this parabola. Which form is most helpful and why?
6. The vertex of a parabola is $(15, -30)$ and the y-intercept is $(0, 25)$. Is this enough information to write the equation? If so, do such, if not explain.

Writing Equations Making Sense of the Three Forms of Quadratic Functions: Teacher Solutions

1. A piece of paper and a hammer are dropped off the top of your school which is 90 feet high. They are both dropped from a still position (that is $v_0=0$ for both). If we ignore air resistance, which object, the paper or hammer, hits the ground first? Provide a mathematical argument that starts by sketching a picture of the graph and concludes with an analysis of the equation.

Possible response: From reading the problem, I notice that the final height, initial height, and initial velocity of both objects are the same. Because their weight is not factored into the equation, their equations and graphs must also be the same. In the equation, $0 = -16t^2 + 90$, 0 is the final height of the objects, 90 is their initial height, and no middle term exists because both objects have an initial velocity of 0. On the graph, the initial height can be seen on the y-axis and the time the objects are in the air can be seen on the x-axis.

2. A potato is fired from a spud-gun at a height of 3m and an initial velocity of 25m/s, write the equation of this potato projectile. How high does the potato reach and at what time does this occur?

$ht = -9.8t^2 + 25t + 3$; The potato reaches a height of 18.9 meters after approximately 1.3 seconds.

3. Two competing catapults launch pumpkins. Catapult A launches from a starting height of 10ft and an initial upward velocity of 45ft/sec. Catapult B launches from a

starting height of 25ft and an initial upward velocity of 40ft/sec. Which pumpkin, A or B, achieves a greater maximum height? Which pumpkin, A or B, is in the air longer? Is it possible from this scenario to determine the distance traveled horizontally by each pumpkin? Explain your choices and justify your answers.

Pumpkin A	Pumpkin B
Maximum (1.41, 41.6)	Maximum (1.25, 50)
Hits the ground in 3.02 seconds	Hits the ground in 3.02 seconds

Horizontal distance is not factored into a projectile motion equation. More information is needed in order to draw any such conclusions.

4. The Angry Birds Screen shot shows two flight paths of two different birds. Using a straight edge, construct a coordinate axes where the center of the slingshot is at the origin. Carefully assign point values to the two parabolas and write an equation for each. Show which points you used and which form of the equation you found most helpful. Using mathematical analysis and your equations do the two birds hit at the same spot? Why or why not?

Answers will vary depending on students' labels of the axes.

5. The points used to model a parabola are (-3, 0), (6, 0) and (4, -5). Write an equation for this parabola. Which form is most helpful and why?

Possible solution: $y = 514(x + 3)(x - 6)$. Two of the three points given were x-intercepts so intercept form of the equation was most helpful.

6. The vertex of a parabola is (15, -30) and the y-intercept is (0, 25). Is this enough information to write the equation? If so, do such, if not explain.

The a value can be attained by using the vertex form. The vertex is (h, k) and the y-intercept serves as the (x, y) coordinate pair. $y = .24(x - 15)^2 - 30$.

4. Knowing vertex and two other points.

Evaluate Understanding

INCLUDED IN THE STUDENT MANUAL

Task #6: Linear or Quadratic

Based on our work in this lesson and your work in the linear unit (Unit 3) explain in words the differences in LINEAR and QUADRATIC equations? How is the structure of the equations different? How is it similar? Are there similar techniques/processes, if so what?

Every student should reflect/write the answers to the following questions:

In addition, pose students with a problem situation to write the equation of a quadratic given three pieces of information. Mimic one of the problems from the worksheet with

values changed.

Closing Activity

Often times in solving quadratic expressions, the form at which students arrive at depends on how they made sense of the structure of the problem. The next activity, “Skelton Tower,” will illustrate this for your class. Allow students time to individually think about the problem followed by collaborative time with a partner. As students work, monitor their progress towards developing different forms of a quadratic in order to select and sequence a class presentation. When most students have arrived at an expression, have groups present their findings. The focus of this discussion and questions should be how their expression for “ n ” blocks reveals their decomposition of the tower. Conclude by making sure all expressions that have been suggested are equivalent.

INCLUDED IN THE STUDENT MANUAL

Task #7: Skeleton Tower

1. How many cubes are needed to build this tower?

Show your calculations

2. How many cubes are needed to build a tower like this, but 12 cubes high?

Explain how you figure out your answer.

3. How would you calculate the number of cubes needed for a tower n cubes high?

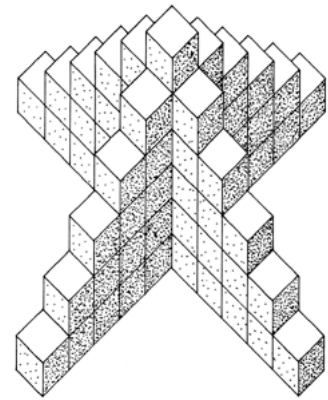

To begin thinking about the end of the unit project, ask students in their groups to record answers to the following questions:

INCLUDED IN THE STUDENT MANUAL

Task #8: Project Planning – Flight of the Gummy Bears

If our goal was to hit a target y -feet away, what would we need to know, what measurements would we need to record, what is our plan? How could we convince the class, using correct mathematical reasoning, that our projectile did indeed travel the furthest horizontally?

If our goal was to shoot the projectile the highest, what would we need to know, what measurements would we need to record, what is our plan? How could we convince the class, using correct mathematical reasoning that our projectile was indeed the highest?

Quadratic Functions

Lesson 4 of 12

Shell Center Formative Assessment Lesson

Description:

This Formative Assessment Lesson focuses on students' ability to garnish information from the structure of the forms of quadratics.

Georgia Standards of Excellence Addressed:

- MGSE9-12.A.SSE.1: Interpret expressions that represent a quantity in terms of its context.
- MGSE9-12.A.SSE.1a: Interpret parts of an expression, such as terms, factors and coefficients, in context.
- MGSE9-12.F.IF.8: Write a function defined by an expression in different but equivalent forms to reveal and explain different properties of the function.
- MGSE9-12.F.IF.8a: Use the process of factoring and completing the square in a quadratic function to show zeros, extreme values and symmetry of the graph, and interpret these in terms of a context. For example, compare and contrast quadratic functions in standard, vertex and intercept forms.
- MGSE9-12.F.IF.9: Compare properties of two functions each represented in a different way (algebraically, graphically, numerically in tables, or by verbal descriptions). For example, given a graph of one function and an algebraic expression for another, say which has the larger maximum.

Standard(s) for Mathematical Practice Emphasized:

- SMP 1: Make sense of problems and persevere in solving them.
- SMP 2: Reason abstractly and quantitatively.
- SMP 3: Construct viable arguments and critique the reasoning of others. arguments, critiquing the reasoning of others and engaging in meaningful mathematical discourse.

The following *Formative Assessment Lesson* is a classroom-ready lesson included to help teachers assess and improve students' understanding of mathematical concepts and skills and their ability to use the "mathematical practices" described in the College Readiness Standards. Research has shown that formative assessment, as embodied in the following lesson, is a powerful way to improve student learning and performance. This approach first allows students to demonstrate their prior understandings and abilities in employing the mathematical processes, and then resolve their own difficulties and misconceptions through structured discussion. This results in more secure long-term learning, reducing the need for re-teaching that otherwise takes so much classroom time. Many often ask, why don't students just remember the procedures they have been taught and practiced? The fact is, that approach works fine in the short term but, as every teacher knows, if procedural knowledge is not underpinned by conceptual understanding, students will quickly forget "how to do it." Read more about the *Formative Assessment Lesson* rationale, structure, and philosophy using the *Brief Guide for Teachers and Administrators* that can be found at <http://map.mathshell.org/materials/index.php>.

CONCEPT DEVELOPMENT

Mathematics Assessment Project
CLASSROOM CHALLENGES
A Formative Assessment Lesson

Forming Quadratics

Mathematics Assessment Resource Service
University of Nottingham & UC Berkeley
Beta Version

For more details, visit: <http://map.mathshell.org>
© 2012 MARS, Shell Center, University of Nottingham
May be reproduced, unmodified, for non-commercial purposes under the Creative Commons license
detailed at <http://creativecommons.org/licenses/by-nc-nd/3.0/> - all other rights reserved

BEFORE THE LESSON

Assessment task: *Quadratic Functions* (15 minutes)

Have the students do this task in class or for homework, a day or more before the formative assessment lesson. This will give you an opportunity to assess the work, and to find out the kinds of difficulties students have with it. You will then be able to target your help more effectively in the follow-up lesson.

Give each student a copy of *Quadratic Functions*.

Briefly introduce the task and help the class to understand the problem and its context.

Read through the task and try to answer it as carefully as you can.

Show all your work so that I can understand your reasoning.

It is important that as far as possible, students are allowed to answer the questions without your assistance.

Students should not worry too much if they cannot understand or do everything, because in the next lesson they will engage in a similar task, which should help them. Explain to students that by the end of the next lesson, they should expect to be able to answer questions such as these confidently. This is their goal.

Quadratic Functions

1. Here are 4 equations of quadratic functions and 4 sketches of the graphs of quadratic functions.

A. $y = x^2 - 6x + 8$	B. $y = (x - 6)(x + 8)$	C. $y = (x - 6)^2 + 8$	D. $y = -(x + 8)(x - 6)$
-----------------------	-------------------------	------------------------	--------------------------

1.

2.

3.

4.

a. Match the equation to its graph and explain your decision.

Equation A *matches* Graph, because
.....

Equation B *matches* Graph, because
.....

Equation C *matches* Graph, because
.....

Equation D *matches* Graph, because
.....

b. Write the co ordinates of the points: P (.....) Q(.....) R (.....) S (.....)

2. The graph of a quadratic function has a y intercept at (0,5) and a minimum at (3, -4).

a. Write the equation of its curve.
.....

b. Write the coordinates of the root(s) of this quadratic function.
.....

Assessing students' responses

Collect students' responses to the task. Make some notes on what their work reveals about their current levels of understanding, and their different problem solving approaches.

We suggest that you do not score students' work. The research shows that this will be counterproductive as it will encourage students to compare their scores, and will distract their attention from what they can do to improve their mathematics.

Instead, help students to make further progress by summarizing their difficulties as a series of questions. Some suggestions for these are given on the next page. These have been drawn from common difficulties observed in trials of this unit.

We suggest that you write a list of your own questions, based on your students' work, using the ideas that follow. You may choose to write questions on each student's work. If you do not have time to do this, select a few questions that will be of help to the majority of students. These can be written on the board at the end of the lesson.

Common issues	Suggested questions and prompts
<p>Q1. Student has difficulty getting started</p>	<ul style="list-style-type: none"> You are given two pieces of information. Which form of a quadratic equation can you match this information to?
<p>Q2. Student makes incorrect assumptions about what the different forms of the equation reveal about the properties of its parabola</p>	<ul style="list-style-type: none"> What does an equation in standard form tell you about the graph? Explain. What does an equation in completed square form tell you about the graph? Explain.
<p>Q2. Student uses an inefficient method For example: For each quadratic function, the student figures out the coordinates of several points by substituting x-values into the equation.</p>	<ul style="list-style-type: none"> Your method is quite difficult work. Think about the information each equation tells you about its graph. Think about the information each graph tells you about its equation.
<p>Student makes a technical error For example: The student makes an error when manipulating an equation.</p>	<ul style="list-style-type: none"> Check your answer.
<p>Student correctly answers all the questions The student needs an extension task.</p>	<ul style="list-style-type: none"> Q2. Can you think of any more coordinates for the key features of the Graphs 1, 2,3, and 4? Explain your answers. Another quadratic has the same coordinates for the minimum, but the y-intercept is (0,14). What is the equation of this curve? [$y = 2x^2 - 12x + 14$]

SUGGESTED LESSON OUTLINE

If you have a short lesson, or you find the lesson is progressing at a slower pace than anticipated, then we suggest you end the lesson after the first collaborative activity and continue in a second lesson.

Whole-class interactive introduction: key features of quadratics (10 minutes)

Give each student either a mini-whiteboard, pen and eraser, or graph paper.

Introduce the lesson with:

Today, we are going to look at the key features of a quadratic curve.

On your mini-whiteboards, draw the x - and y -axis and sketch two quadratic curves that look quite different from each other.

Allow students to work for a few minutes and then ask them to show you their whiteboards.

Be selective as to which student you ask to explain his or her graphs. Look for two sets of curves in particular:

- one of which has a maximum point, the other a minimum;
- one of which one has two roots, the other one or none;
- that are not parabolas.

What makes your two graphs different?

What are the common features of your graphs?

Elicit responses from the class and try to keep your own interventions to a minimum. Encourage students to use mathematical terms such as roots, y -intercepts, turning points, maximum, minimum.

As students suggest key features, write them as a list on the board under the heading 'Key Features of a Graph of a Quadratic'.

Ask about turning points:

How many turning points does each of your graphs have? Is this turning point a maximum or minimum?

Can the curve of a quadratic function have more than one turning point/no turning points?

If all students have drawn graphs with minimums, ask students to draw one with a maximum.

Ask about roots:

How many roots does each of your graphs have?

Where are these roots on your curve?

Does anyone have a graph with a different number of roots?

How many roots can a quadratic have?

If all students have drawn graphs with two roots, ask a student to draw one with one or no roots.

Ask about y -intercepts:

Has anyone drawn a graph with different y -intercepts?

Do all quadratic curves have a y -intercept?

Can a quadratic have more than one y -intercept?

Write on the board these three equations of quadratic functions:

Standard Form:	Factored Form:	Completed Square Form:
1. $y = x^2 - 10x + 24$	2. $y = (x - 4)(x - 6)$	3. $y = (x - 5)^2 - 1$

Here are the equations of three quadratic functions.

Without performing any algebraic manipulations, write the coordinates of a key feature of each of their graphs.

For each equation, select a different key feature.

Explain to students they should use key features from the list on the board.

For example, students may answer:

Equation 1. The y -intercept is at the point $(0,24)$. The graph has a minimum, because the coefficient of x is positive.

Equation 2. The graph has a minimum and has roots at $(4,0)$ and $(6,0)$.

Equation 3. The graph has a minimum turning point at $(5, -1)$

If students struggle to write anything about Equation 3, ask:

How can we obtain the coordinates of the minimum from Equation 3?

To obtain the minimum value for y , what must be the value of x ? How do you know?

Equation 3 shows that the graph has a minimum when $x = 5$. This is because $(x - 5)^2$ is always greater than or equal to zero, and it takes a minimum value of 0 when $x = 5$.

What do the equations have in common? [They are different representations of the same function.]

Completed square form can also be referred to as vertex form.

Now write these two equations on the board:

$$4. y = -(x + 4)(x - 5) \qquad 5. y = -2(x + 4)(x - 5)$$

What is the same and what is different about the graphs of these two equations? How do you know?

For example, students may answer:

- Both parabolas have roots at $(-4,0)$ and $(5,0)$.
- Both parabolas have a maximum turning point.
- Equation 2 will be steeper than Equation 1 (for the same x value Equation 2's y value will be double that of Equation 1).

Whole-class introduction to Dominos (10 minutes)

Organize the class into pairs. Give each pair of students cut-up 'dominos' A, E, and H from *Domino Cards 1* and *Domino Cards 2*.

Explain to the class that they are about to match graphs of quadratics with their equations, in the same way that two dominoes are matched. If students are unsure how to play dominos, spend a couple of minutes explaining the game.

The graph on one 'domino' is linked to its equations, which is on another 'domino'.

Place Card H on your desk. Figure out, which of the two remaining cards should be placed to the right of card H and which should be placed to its left.

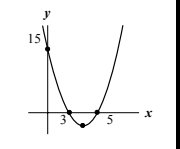
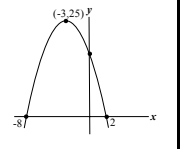
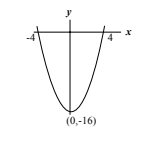
<p>A</p> $y = x^2 + 2x - 35$ <p>.....</p> <p>.....</p>		<p>H</p> $y = x^2 - 8x + 15$ $y = (x - 3)(x - 5)$ $y = (x - 4)^2 - 1$		<p>E</p> $y = -x^2 - 6x + 16$ $y = -(x + 8)(x - 2)$ $y = -(x + 3)^2 + 25$	
---	---	--	--	--	---

Encourage students to explain **why** each form of the equation matches the curve:

Dwaine, explain to me how you matched the cards.

Alex, please repeat Dwaine's explanation in your own words.

Which form of the function makes it easy to determine the coordinates of the roots/ y-intercept/ turning point of the parabola?

Are the three different forms of the function equivalent? How can you tell?

The parabola on Domino A is missing the coordinates of its minimum. The parabola on Domino H is missing the coordinates of its y-intercept. Ask students to use the information in the equations to add these coordinates.

What are the coordinates of the minimum of the parabola on Card A? What equation did you use to work it out? [(4, -1)]

What are the coordinates of the y-intercept of the parabola on Card H? What equation did you use to work it out? [(0, 16)]

At this stage, students may find it helpful to write what each form of the function reveals about the key features of its graph.

If you think students need further work on understanding the relationship between a graph and its equations, then ask students to make up three different algebraic functions, the first in standard form, the second in factored form, and the third in completed square form. Students are then to take these equations to a neighboring pair and ask them to explain to each other what each equation reveals about its curve.

Collaborative work: matching the dominos (15 minutes)

Give each pair of students all the remaining cut up *Domino Cards*.

Explain to students that the aim is to produce a closed loop of dominos, with the last graph connecting to the equations on 'domino' A. Students may find it easier to begin by laying the dominos out in a long column or row rather than in a loop.

You may want to use Slide P-1 of the projector resource to display the following instructions.

Take turns at matching pairs of dominos that you think belong together.

Each time you do this, explain your thinking clearly and carefully to your partner.

It is important that you both understand the matches. If you don't agree or understand ask your partner to explain their reasoning. You are both responsible for each other's learning.

On some cards an equation or part of an equation is missing. Do not worry about this, as you can carry out this task without this information.

You have two tasks during small-group work: to make a note of student approaches to the task, and support student problem solving.

Make a note of student approaches to the task

Notice how students make a start on the task, where they get stuck, and how they respond if they do come to a halt. You can use this information to focus a whole-class discussion towards the end of the lesson.

Support student problem solving

Try not to make suggestions that move students towards a particular approach to this task. Instead, ask questions to help students clarify their thinking. If several students in the class are struggling with the same issue, write a relevant question on the board. You might also ask a student who has performed well on a particular part of the task to help a struggling student.

The following questions and prompts may be helpful:

Which form of the function makes it easy to determine the coordinates of the roots /y-intercept/turning point of the parabola?

How many roots does this function have? How do you know? How are these shown on the graph?

Will this function be shaped like a hill or a valley? How do you know?

Sharing work (5 minutes)

As students finish matching the cards, ask one student from each group to visit another group's desk.

If you are staying at your desk, be ready to explain the reasons for your group's matches.

If you are visiting another group, write your card matches on a piece of paper. Go to another group's desk and check to see which matches are different from your own.

If there are differences, ask for an explanation. If you still don't agree, explain your own thinking.

When you return to your own desk, you need to consider as a pair whether to make any changes to your own work.

You may want to use Slide P-2 of the projector resource to display these instructions.

Collaborative work: completing the equations (15 minutes)

Now you have matched all the domino cards, I would like you to use the information on the graphs to fill in the missing equations and parts of equations.

You shouldn't need to do any algebraic manipulation!

Support the students as in the first collaborative activity.

For students who are struggling ask:

This equation is in standard form but the final number is missing. Looking at its graph, what is the value for y when x is zero? How can you use this to complete the standard form equation?

You need to add the factored form equation. Looking at its graph, what is the value for x when y is zero? How can you use this to complete the factored form equation?

Sharing work (5 minutes)

When students have completed the task, ask the student who has not already visited another pair to check their answers those of another pair of students. Students are to share their reasoning as they did earlier in the lesson unit.

Extension work

If a pair of students successfully completes the task then they could create their own dominos using the reverse side of the existing ones. To do this students will need to use algebraic manipulation to figure out all three forms of the function. Once students have written on all the dominos they should give them to another pair to match up. This is a demanding task so you may want to limit the number of dominos students use.

Whole-class discussion: overcoming misconceptions (10 minutes)

Organize a discussion about what has been learned. The intention is to focus on the relationships between the different representations of quadratic functions, not checking that everyone gets the right answers.

Ella, where did you place this card? How did you decide?

Ben, can you put that into your own words?

What are the missing equations for this graph? How did you work them out?

Did anyone use a different method?

Improving individual solutions to the assessment task (10 minutes)

Return to the students their original assessment *Quadratic Functions*, as well as a second blank copy of the task.

Look at your original responses and think about what you have learned this lesson.

Using what you have learned, try to improve your work.

If you have not added questions to individual pieces of work, then write your list of questions on the board. Students should select from this list only the questions they think are appropriate to their own work.

If you find you are running out of time, then you could set this task in the next lesson or for homework.

SOLUTIONS

Assessment task: Quadratic Functions

1.
 - a. A matches 3, because it has two positive roots and a positive y -intercept.
B matches 4, because it has one positive and one negative root.
C matches 1, because it is the only function with no roots.
D matches 2 because it is the only function with a maximum value.
 - b. P (6,8); Q (-8,0); R(4,0); S(0, -48).
2.
 - a. $y = (x - 3)^2 - 4$ or $y = x^2 - 6x + 5$
 - b. $y = (x - 5)(x - 1)$. The function crosses the x -axis at (5,0) and (1,0).

Collaborative work: Matching the dominos

Cards should be placed in this order:

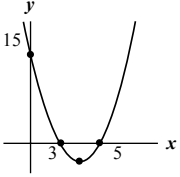
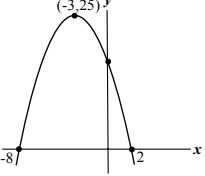
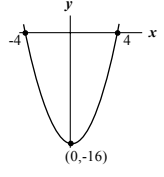
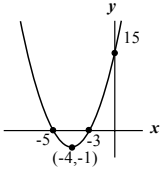
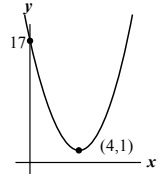
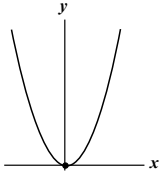
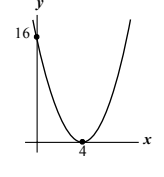
<p>A</p> $y = x^2 + 2x - 35$ $y = (x - 5)(x + 7)$ $y = (x + 1)^2 - 36$	
<p>H</p> $y = x^2 - 8x + 15$ $y = (x - 3)(x - 5)$ $y = (x - 4)^2 - 1$	
<p>E</p> $y = -x^2 - 6x + 16$ $y = -(x + 8)(x - 2)$ $y = -(x + 3)^2 + 25$	
<p>F</p> $y = x^2 - 16$ $y = (x - 4)(x + 4)$ $y = (x - 0)^2 - 16$	
<p>B</p> $y = x^2 + 8x + 15$ $y = (x + 5)(x + 3)$ $y = (x + 4)^2 - 1$	
<p>G</p> $y = x^2 - 8x + 17$ <p>No roots</p> $y = (x - 4)^2 + 1$	
<p>J</p> $y = x^2$ $y = (x - 0)(x - 0)$ $y = (x - 0)^2 + 0$	

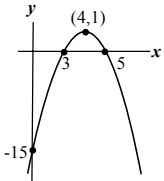
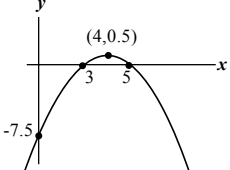
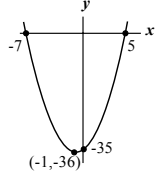
<p>C</p> $y = x^2 - 8x + 16$ $y = (x - 4)(x - 4)$ $y = (x - 4)^2 + 0$	
<p>D</p> $y = -x^2 + 8x - 15$ $y = -(x - 3)(x - 5)$ $y = -(x - 4)^2 + 1$	
<p>I</p> $y = -\frac{1}{2}x^2 + 4x - 7.5$ $y = -\frac{(x - 3)(x - 5)}{2}$ $y = -\frac{(x - 4)^2}{2} + \frac{1}{2}$	

Quadratic Functions

1. Here are 4 equations of quadratic functions and 4 sketches of the graphs of quadratic functions.

A. $y = x^2 - 6x + 8$	B. $y = (x - 6)(x + 8)$	C. $y = (x - 6)^2 + 8$	D. $y = -(x + 8)(x - 6)$
-----------------------	-------------------------	------------------------	--------------------------

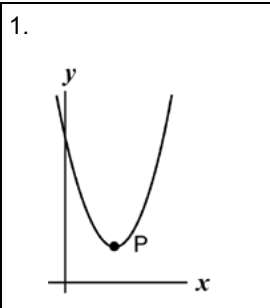
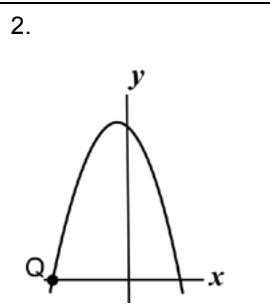
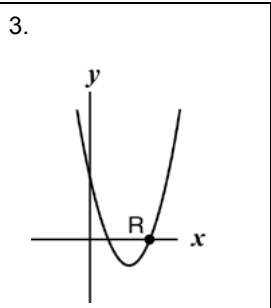
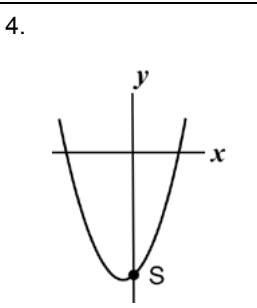
<p>1.</p> 	<p>2.</p> 	<p>3.</p> 	<p>4.</p> 
---	---	--	---

a. Match the equation to its graph and explain your decision.

Equation A **matches** Graph, because

.....

Equation B **matches** Graph, because

.....

Equation C **matches** Graph, because

.....

Equation D **matches** Graph, because

.....

b. Write the co ordinates of the points: P (.....) Q(.....) R (.....) S (.....)

2. The graph of a quadratic function has a y intercept at (0,5) and a minimum at (3, -4).

a. Write the equation of its curve.

.....

b. Write the coordinates of the root(s) of this quadratic function.

.....

Domino Cards: 1

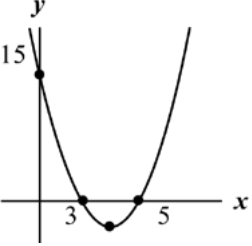
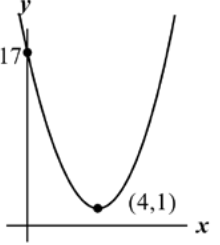
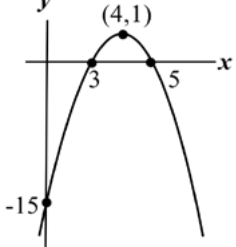
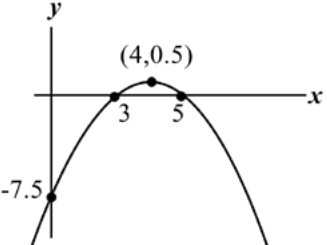
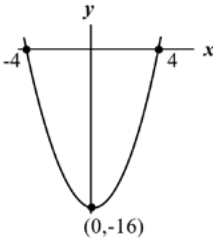
<p>A</p> $y = x^2 + 2x - 35$ $y = \dots\dots\dots$ $y = \dots\dots\dots$	
<p>B</p> $y = x^2 + 8x\dots\dots\dots$ $y = \dots\dots\dots$ $y = (x + 4)^2 - 1$	
<p>C</p> $y = x^2 - 8x\dots\dots\dots$ $y = (x - 4)(x - 4)$ $y = \dots\dots\dots$	
<p>D</p> $y = -x^2 + 8x\dots\dots\dots$ $y = \dots\dots\dots$ $y = -(x - 4)^2 + 1$	
<p>E</p> $y = -x^2 - 6x + 16$ $y = -(x + 8)(x - 2)$ $y = -(x + 3)^2 + 25$	

Domino Cards: 2

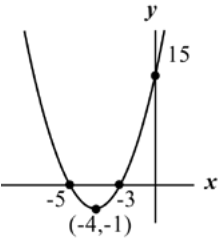
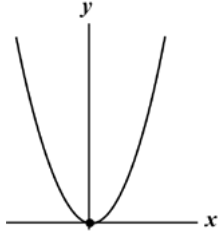
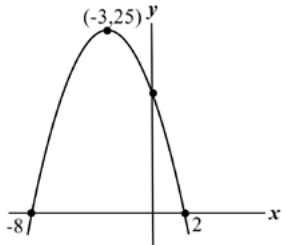
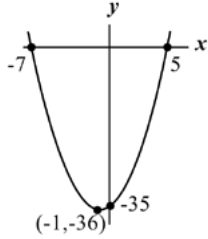
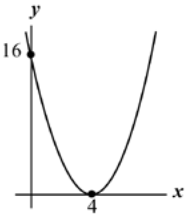
<p>F</p> <p>$y = x^2$</p> <p>$y = (x - 4)(x + 4)$</p> <p>$y =$</p>	
<p>G</p> <p>$y = x^2 - 8x$.....</p> <p style="text-align: center;">No roots</p> <p>$y =$</p>	
<p>H</p> <p>$y = x^2 - 8x + 15$</p> <p>$y = (x - 3)(x - 5)$</p> <p>$y = (x - 4)^2 - 1$</p>	
<p>I</p> <p>$y = -\frac{1}{2}x^2 + 4x$.....</p> <p>$y = -\frac{(x - 3)(x - 5)}{2}$</p> <p>$y =$</p>	
<p>J</p> <p>$y = x^2$</p> <p>$y =$</p> <p>$y =$</p>	

Matching Dominos

- Take turns at matching pairs of dominos that you think belong together.
- Each time you do this, explain your thinking clearly and carefully to your partner.
- It is important that you both understand the matches. If you don't agree or understand, ask your partner to explain their reasoning. You are both responsible for each other's learning.
- On some cards an equation or part of an equation is missing. Do not worry about this, as you can carry out this task without this information.

Sharing Work

- One student from each group is to visit another group's poster.
- If you are staying at your desk, be ready to explain the reasons for your group's matches.
- If you are visiting another group:
 - Write your card matches on a piece of paper.
 - Go to another group's desk and check to see which matches are different from your own.
 - If there are differences, ask for an explanation. If you still don't agree, explain your own thinking.
 - When you return to your own desk, you need to consider as a pair whether to make any changes to your own work.

Mathematics Assessment Project
CLASSROOM CHALLENGES

This lesson was designed and developed by the
Shell Center Team
at the
University of Nottingham
Malcolm Swan, Nichola Clarke, Clare Dawson, Sheila Evans
with
Hugh Burkhardt, Rita Crust, Andy Noyes, and Daniel Pead

It was refined on the basis of reports from teams of observers led by
David Foster, Mary Bouck, and Diane Schaefer
based on their observation of trials in US classrooms
along with comments from teachers and other users.

This project was conceived and directed for
MARS: Mathematics Assessment Resource Service
by
Alan Schoenfeld, Hugh Burkhardt, Daniel Pead, and Malcolm Swan
and based at the University of California, Berkeley

We are grateful to the many teachers, in the UK and the US, who trialed earlier versions
of these materials in their classrooms, to their students, and to
Judith Mills, Carol Hill, and Alvaro Villanueva who contributed to the design.

This development would not have been possible without the support of
Bill & Melinda Gates Foundation
We are particularly grateful to
Carina Wong, Melissa Chabran, and Jamie McKee

© 2012 MARS, Shell Center, University of Nottingham
This material may be reproduced and distributed, without modification, for non-commercial purposes,
under the Creative Commons License detailed at <http://creativecommons.org/licenses/by-nc-nd/3.0/>
All other rights reserved.
Please contact map.info@mathshell.org if this license does not meet your needs.

Quadratic Functions

Lesson 5 of 12

Same Story, Different Equation – Moving Between the Forms

Description:

This lesson focuses on moving between forms by drawing on skills of multiplying and factoring. Students will move from vertex form, but at this point will not be expected to force equations into vertex form as that is the next lesson.

Georgia Standards of Excellence Addressed:

- MGSE9-12.A.SSE.1: Interpret expressions that represent a quantity in terms of its context.
- MGSE9-12.A.SSE.1a: Interpret parts of an expression, such as terms, factors and coefficients, in context.
- MGSE9-12.A.SSE.2: Use the structure of an expression to rewrite it in different equivalent forms. For example, see $x^4 - y^4$ as $(x^2)^2 - (y^2)^2$, thus recognizing it as a difference of squares that can be factored as $(x^2 - y^2)(x^2 + y^2)$.
- MGSE9-12.A.SSE.3: Choose and produce an equivalent form of an expression to reveal and explain properties of the quantity represented by the expression.
- MGSE9-12.A.SSE.3a: Factor any quadratic expression to reveal the zeros of the function defined by the expression.
- MGSE9-12.A.CED.1: Create equations and inequalities in one variable and use them to solve problems. Include equations arising from linear, quadratic, simple rational, and exponential functions (integer inputs only).
- MGSE9-12.F.IF.4: Using tables, graphs, and verbal descriptions, interpret the key characteristics of a function which models the relationship between two quantities. Sketch a graph showing key features including: intercepts; interval where the function is increasing, decreasing, positive, or negative; relative maximums and minimums; symmetries; end behavior; and periodicity.
- MGSE9-12.F.IF.7: Graph functions expressed algebraically and show key features of the graph both by hand and by using technology.
- MGSE9-12.F.IF.7a: Graph linear and quadratic functions and show intercepts, maxima and minima (as determined by the function or by context).

Standard(s) for Mathematical Practice Emphasized:

- SMP 1: Make sense of problems and persevere in solving them.
- SMP 3: Construct viable arguments and critique the reasoning of others.
- SMP 7: Look for and make use of structure.

Sequence of
Instruction

Activities Checklist

Engage



In groups of three, students will each be given the same quadratic function but in a different form. [Example: $f(x) = (x - 3)^2 - 1$, $g(x) = x^2 - 6x + 8$, $h(x) = (x - 4)(x - 2)$.] Working with a different form, each student will individually complete a “target” Frayer model displaying the table, graph, equation and verbal description of their function. Verbal description should focus on rates of change and how this changes in a quadratic. Students should compare the correspondences between equations, verbal descriptions, tables and graphs on their targets within group and notice that the table and graph are the same but the function representation is different.

Explore



The intent of this exploration is to have students arrive at the conjecture that the same quadratic equation can be represented in three different formats. They should see the structure of the representations may be different but the functions are equivalent based off of the multiple representations. Resist the urge to “spoon-feed” students’ thinking; rather encourage students to look critically at the structure of the representations.

Each group should present their three targets. To help students compare the effectiveness of arguments use the following questions: Within a group, it appears we all have the same function. Why? How can you be certain that these are all the same?

Now regroup students with common forms (all vertex forms together, all standard forms together and all factored forms together). It may be necessary to have two groups of each.

Ask students:

In your new group, what is “visible” in the function in regards to your graph and/or table? As a group, come to a consensus about how to garnish information from your form to present to the class.

In addition, work in your groups to brainstorm answers to the following questions. Draw on the structure of the equation and information previously studied in this course to help generate ideas.

1. How can you get from factored form to standard form?
2. How can you get from standard form to factored form? Does this always work? Why or why not?
3. How can you get from vertex form to standard form?
4. How can you get from vertex form to factored form?
5. Regardless of what form you start with, can you always get to the other forms? Explain.

(At this point, it is okay for students to say getting to vertex form is not possible without the group; encourage students to think about this. Keep the possibility of algebraic manipulation open as this is the next lesson. Students should be able to use skills from Unit 1 and previous courses to expand factored and vertex forms of quadratics.)

Explanation



As students report out from their common forms groups, all students should complete a tri-fold graphic organizer to keep track of what the various forms of a quadratic function offer.

On the board or on large poster paper, write “Standard Form $ax^2 + bx + c$ ” “Factored Form $(x - m)(x + n)$ ” and “Vertex Form $a(x - h)^2 + k$.”

Draw arrows from each to each. List ideas generated by students of how to move from form to form. Based on the ability of the class it may be necessary to write the forms with numbers rather than constant coefficients. Students should be familiar from Unit 1 how to multiply binomials and factor.

Classroom discourse should ensure understanding of the limitations of factoring and should loop back around to the idea of the x-intercepts.

Following this explanation, students should complete the tri-fold graphic organizer from group reports (NOT direct instruction of the teacher).

Practice Together / in Small Groups / Individually



In learning teams, students should begin *The Same Yet Different* problem set. Emphasis should be on the structure of multiple representations and building understanding of what form makes the most sense for various situations.

INCLUDED IN THE STUDENT MANUAL

Task #9: The Same Yet Different

The purpose of this set of questions is to use the FORM to answer questions or to perhaps write the form to answer questions. You may only use a calculator for basic computational facts.

1. Suppose $h(t) = -5t^2 + 10t + 3$ is an expression giving the height of a diver above the water (in meters), t seconds after the diver leaves the springboard.
 - (a) How high above the water is the springboard? Explain how you know.
 - (b) When does the diver hit the water? Can you do this without a graphic calculator?
 - (c) At what time on the diver's descent toward the water is the diver again at the same height as the springboard?
 - (d) When does the diver reach the peak of the dive? (*You don't know how to do vertex form yet, but the idea that the vertex occurs half way between the x -intercepts should be encouraged as a method for solving.*)
2. A ball thrown vertically upward at a speed of v ft/sec rises a distance d feet in t , given by $d = 6 + vt - 16t^2$. Write an equation whose solution is:
 - (a) The time it takes a ball thrown at a speed of 88 ft/sec to rise 20 feet.
 - (b) The speed with which the ball must be thrown to rise 20 feet in 2 seconds.

<http://www.illustrativemathematics.org/illustrations/437>

3. A company's profit (in thousands of dollars) from an item depends on the price of the item. Three different expressions for the profit at a price of p dollars follow:
 $-2p^2 + 24p - 54$
 $-2(p - 3)(p - 9)$
 $-2(p - 6)^2 + 18$
How could you convince someone that the three expressions are equivalent?
Which form is most useful for finding:
 - (a) The break-even prices? What are those prices, and how do you know?
 - (b) The profit when the price is 0? What is that profit, and what does it tell about the business situation?
 - (c) The price that will yield maximum profit? What is that price?

INCLUDED IN THE STUDENT MANUAL

4. Coyote was chasing roadrunner, seeing no easy escape, Road Runner jumped off a cliff towering above the roaring river below. Molly mathematician was observing the chase and obtained a digital picture of this fall. Using her mathematical knowledge, Molly modeled the Road Runner's fall with the following quadratic functions:

$$h(t) = -16t^2 + 32t + 48$$

$$h(t) = -16(t + 1)(t - 3)$$

$$h(t) = -16(t - 1)^2 + 64$$

- Why does Molly have three equations?
 - Could you convince others that all three of these rules are mathematically equivalent?
 - Which of the rules would be most helpful in answering each of these questions? Explain.
 - What is the maximum height the Road Runner reaches and when will it occur?
 - When would the Road Runner splash into the river?
 - At what height was the Road Runner when he jumped off the cliff?
5. Complete the missing entries in the table. Each row represents the same quadratic function.

	Standard Form	Factored Form	Vertex Form	X-Intercepts	Y-Intercepts	Vertex
f(x)	$x^2 - 4x - 32$		$(x - 2)^2 - 36$			
g(x)		$(x - 3)(x + 6)$				
h(x)	$3x^2 - 10x - 8$					
k(x)			$(x - 2)^2 - 49$			
m(x)			$-(x + 3)^2 + 25$			

The Same Yet Different Handout: Possible Solutions

3. A company's profit (in thousands of dollars) from an item depends on the price of the item. Three different expressions for the profit at a price of p dollars follow:

$$-2p^2 + 24p - 54 \qquad -2(p - 3)(p - 9) \qquad -2(p - 6)^2 + 18$$

How could you convince someone that the three expressions are equivalent?

One could graph all three functions and look for the same, overlapping, graph. Additionally looking at the function table should show three equivalent outputs for each function.

Algebraic manipulation could also prove symbolically that all three functions are equivalent.

Which form is most useful for finding:

- (a) The break-even prices? What are those prices, and how do you know?

The second equation— the factored form— shows my break-even points. Prices of \$3 and \$9 will yield an output profit of \$0. Making \$0 is breaking even, neither losing nor making money.

- (b) The profit when the price is 0? What is that profit, and what does it tell about the business situation?

The first equation reveals that when the price is \$0, the profit will be -\$54. This is easily seen in this form because when $p = 0$ all terms with p in them are equal to 0.

- (c) The price that will yield maximum profit? What is that price?

The vertex form, or the last equation shown, shows the maximum profit is \$18 for a price of \$6.

4. Coyote was chasing roadrunner, seeing no easy escape, Road Runner jumped off a cliff towering above the roaring river below. Molly mathematician was observing the chase and obtained a digital picture of this fall. Using her mathematical knowledge, Molly modeled the Road Runner's fall with the following quadratic functions:

$$h(t) = -16t^2 + 32t + 48$$

$$h(t) = -16(t + 1)(t - 3)$$

$$h(t) = -16(t - 1)^2 + 64$$

- a. Why does Molly have three equations?

Molly used her data in different ways to record the flight of the Road Runner. The different equations are all the same but reveal different key features of the function.

- b. Could you convince others that all three of these rules are mathematically equivalent?

One could graph all three functions and look for the same, overlapping, graph. Additionally looking at the function table should show three equivalent outputs for each function. Algebraic manipulation could also prove symbolically that all three functions are equivalent.

- c. Which of the rules would be most helpful in answering each of these questions? Explain.
- What is the maximum height the Road Runner reaches and when will it occur?
The Road Runner reaches his maximum height at the vertex of his fall. This occurs 1 second into the fall at a height of 64.
 - When would the Road Runner splash into the river?
The factored form of the equation shows that at time $t = -1$ and $t = 3$, the road runner is hitting the river. However, $t = -1$ does not make sense in context of this problem; thus the Road Runner hits the river at $t = 3$ after he fell off the cliff.
 - At what height was the Road Runner when he jumped off the cliff?
The Road Runner was on a cliff 48 units above the river. This would occur at $t = 0$, or when his fall started, and is most easily seen in the first equation (standard form).

5. Complete the missing entries in the table. Each row represents the same quadratic function.

Students can find the vertex in the second and third rows by realizing the vertex occurs exactly half-way between the x-intercepts. To find the y-value, plug in the appropriate x-value of the vertex.

	Standard Form	Factored Form	Vertex Form	X-Intercepts	Y-Intercepts	Vertex
f(x)	$x^2 - 4x - 32$	$(x - 8)(x + 4)$	$(x - 2)^2 - 36$	$(-4, 0)$ $(8, 0)$	$(0, -32)$	$(2, -36)$
g(x)	$x^2 + 3x - 18$	$(x - 3)(x + 6)$	-----	$(-6, 0)$ $(3, 0)$	$(0, -18)$	$(-1.5, -20.25)$
h(x)	$3x^2 - 10x - 8$	$(3x + 2)(x - 4)$	-----	$(-\frac{2}{3}, 0)$ $(4, 0)$	$(0, -8)$	$(\frac{5}{3}, -\frac{49}{3})$
k(x)	$x^2 - 4x - 45$	$(x - 9)(x + 5)$	$(x - 2)^2 - 49$	$(-5, 0)$, $(9, 0)$	$(0, -45)$	$(2, -49)$
m(x)	$-(x^2 + 6x - 16)$	$-(x + 8)(x - 2)$	$-(x + 3)^2 + 25$	$(-8, 0)$ $(2, 0)$	$(0, 16)$	$(-3, 25)$

Evaluate Understanding

As students are working in learning teams, be cognitive of the discussion students are having. If groups are not discussing the mathematics ask probing questions to members. Make sure students are using different forms and can move fluidly and efficiently between the two forms.

Individually have students write the benefits of each of the three forms and perhaps the pitfalls of the forms. This should be completed individually prior to the closing activity.

Closing Activity

Chalk Talk on poster previously placed on the board regarding Standard Form, Factored Form, and Vertex Form. Students should write/graffiti a short idea on the poster. This can be a hint, something to remember, a picture definition, etc. This works best with markers for visibility's sake.

Quadratic Functions

Lesson 6 of 12

Getting to Vertex Form - Completing the Square

Description:

Students will use algebra tiles to discover what is meant spatially by “completing the square.” This lesson builds a conceptual understanding of the process of completing the square.

Georgia Standards of Excellence Addressed:

- MGSE9-12.A.SSE.1: Interpret expressions that represent a quantity in terms of its context.
- MGSE9-12.A.SSE.1a: Interpret parts of an expression, such as terms, factors and coefficients, in context.
- MGSE9-12.A.SSE.2: Use the structure of an expression to rewrite it in different equivalent forms. For example, see $x^4 - y^4$ as $(x^2)^2 - (y^2)^2$, thus recognizing it as a difference of squares that can be factored as $(x^2 - y^2)(x^2 + y^2)$.
- MGSE9-12.A.SSE.3: Choose and produce an equivalent form of an expression to reveal and explain properties of the quantity represented by the expression.
- MGSE9-12.A.SSE.3b: Complete the square in a quadratic expression to reveal the maximum or minimum value of the function defined by the expression.
- MGSE9-12.F.IF.4: Using tables, graphs, and verbal descriptions, interpret the key characteristics of a function which models the relationship between two quantities. Sketch a graph showing key features including: intercepts; interval where the function is increasing, decreasing, positive, or negative; relative maximums and minimums; symmetries; end behavior; and periodicity.
- MGSE9-12.F.IF.7: Graph functions expressed algebraically and show key features of the graph both by hand and by using technology.
- MGSE9-12.F.IF.7a: Graph linear and quadratic functions and show intercepts, maxima and minima (as determined by the function or by context).

Standard(s) for Mathematical Practice Emphasized:

- SMP 2: Reason abstractly and quantitatively.
- SMP 4: Model with mathematics.
- SMP 7: Look for and make use of structure.

Sequence of Instruction

Activities Checklist

Engage



Have students use an area model to expand the following binomials:

$(x + 3)^2$, $(x - 5)^2$, $(x + 3)(x - 3)$.

The use of an area model, or algebra tiles, is important to the development of this lesson. Make sure students understand the area representations using algebra tiles.

An online, digital version of algebra tiles can be found at:

<http://technology.cpm.org/general/tiles/>.

Possible solutions:

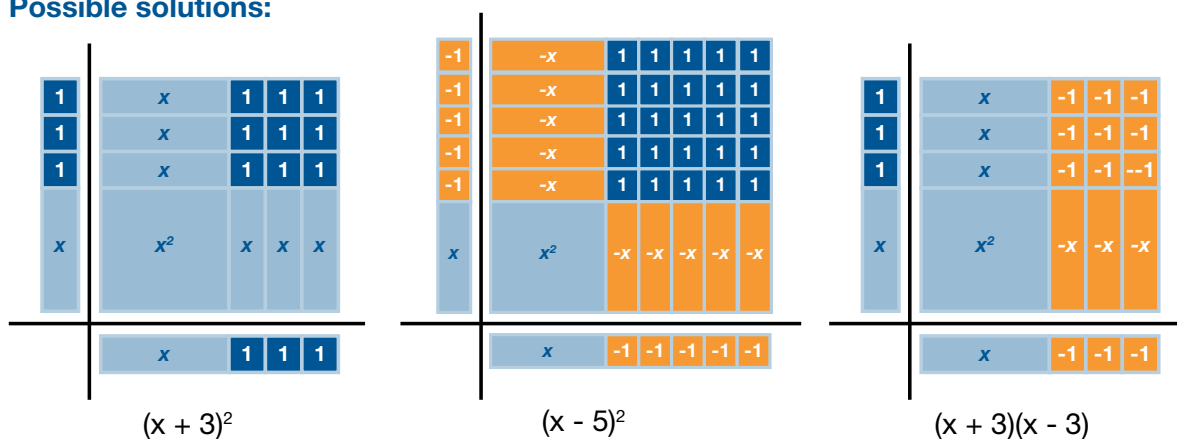

From the previous lesson write the following in standard form:

$(x - 4)^2 + 6$

Solution: $x^2 - 8x + 22$

$3(x - 3)^2 - 10$

Solution: $3x^2 - 18x + 17$

INCLUDED IN THE STUDENT MANUAL

Task #10: Flying Marshmallows

This is a non-graphing only calculator activity.

See Flying Marshmallows Handout (there's two—one is a recording sheet, one is a "target" organizer.)

The objective: The team who presents the best case for the flight of their marshmallow will win the "prize."

You will have 15 minutes to collect data from different shots, from different team members, and garnish everything you can about the flight of your marshmallow. Gather enough data in order that you can provide convincing evidence that your teams know the most about the flight of your marshmallow.

Teacher Note: This activity is similar to the gummy bear activity in lesson one. Students should at this point provide more sophisticated mathematical models using their ability to decontextualize the flight of a marshmallow into a mathematical function.

Explore



INCLUDED IN THE STUDENT MANUAL

Task #11: Flying Marshmallows Follow-Up

Pick ONE flight path from your data to answer the following questions:

In factored form the flight of your marshmallow looks like:

$$h(t) = -16(x - t_1)(x - t_2).$$

- What are -16 , t_1 , and t_2 ?
- Write the equation for the flight of your marshmallow in factored form.
- Write this equation in *standard form*.
- From either of these forms, what was the maximum height your marshmallow obtained?
- When was this height obtained? Use this information, along with one of your other points to write the equation for your marshmallows flight in vertex form— $y = a(x - h)^2 + k$.

Teacher note: This will take quite a bit of algebraic manipulation as students will have to “plug” in the vertex they found then use an additional point—one of their data points to solve for the missing value of “a.”

Explanation



There has to be a quicker way – an algebraic way – to write equations in vertex form.

Put three quadratic functions on the board, all in vertex form. Suggested equations:

$$f(x) = (x - 2)^2 + 4 \quad g(x) = 4(x + 9)^2 - 5 \quad h(x) = \frac{1}{2}(x - 3)^2 + 1$$

Facilitate a class discussion using the following questions:

What do you notice is similar in the structure of the three equations on the board?

How is this structure different from standard form and factored form?

(Teacher note: You want students to recognize that vertex form has a perfect square piece in the structure of the function. The other forms do not have this.)

Geometrically, what is a square?

Using algebra tiles, ask students to arrange $x^2 + 6x + 9$ into a square arrangement.

Possible Solutions:

Students will often arrange tiles like this—

This representation is correct but may not be considered “conventional.” The dimensions of this square are $(x + 3)$ by $(x + 3)$.

1	1	x	1
x	x	x^2	x
1	1	x	1
1	1	x	1

The following is the more “conventional” representation of this array:

x^2	x	x	x
x	1	1	1
x	1	1	1
x	1	1	1

Based off of your assessment of students understanding at this point, include more perfect square examples if needed.

Ask students to arrange $x^2 + 4x + 3$ into a perfect square.

x^2	x	x
x	1	1
x	1	

Why won't this work?

(There is not enough "ones" to make this current quadratic fit into a perfect square as written.)

Practice Together / in Small Groups / Individually



Students will build upon this logic of arranging algebra tiles into a square arrangement to construct the structure of a vertex form. The group handout provided allows students to work in groups to reason abstractly to arrive at the vertex form of an equation.

Use handout for Lesson 6 to guide.

It is important to let students productively struggle rather than being teacher guided in the handout.

INCLUDED IN THE STUDENT MANUAL

Task #12: Completing the Square

Method 1 – Algebra Tiles:

How does this algebra model tile representation illustrate the product of $(x + 4)^2$?

Let's look at an expanded form: $f(x) = x^2 + 8x + 10$

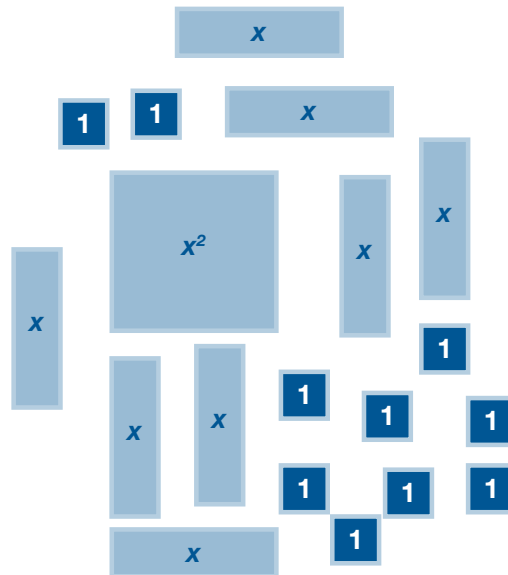

x^2	x	x	x	x
x	1	1	1	1
x	1	1	1	1
x	1	1	1	1
x	1	1	1	1

Try to arrange this set of tiles into a PERFECT SQUARE.

What problems are you running into? What could be done to remedy this situation? If I were to allow you extra tiles, what would you need? Or would you rather take some away?

If you ignored for the time being all your “ones” how many ones would you need to make a PERFECT SQUARE?

How could we keep this net gain at zero?

The vertex form of this quadratic is $f(x) = (x + 4)^2 - 6$. Explain how this process helped me arrive at the vertex form.

INCLUDED IN THE STUDENT MANUAL

Completing the Square

Method 2 – Area Model (Algebra tiles generalized):

The squared expression $(x + 4)^2$ is represented geometrically to the right. Explain/make sense of this model.

	x	4
x	x^2	4x
4	4x	16

Let's try to reverse the process. Say I am building a PERFECT SQUARE and have the following. In each case, decide what it is I need to add on to have a completely perfect square. Draw an area model to illustrate your thought process.

a) $x^2 - 8x$

b) $x^2 - 10x$

c) $x^2 - 3x$

d) $x^2 + 14x$

e) $x^2 + 5x$

Now, what if I have $x^2 + 6x - 10$ and I would like to write it in vertex form. First I need a perfect square. Ignore the -10 and figure out what it is I need to complete my perfect square with $x^2 + 6x$.

How can you keep balance with what you have added to the problem?

Write $x^2 + 6x - 10$ in vertex form.

Method 1 – Algebra Tiles: Possible Teacher Solutions

How does this algebra model tile representation illustrate the product of $(x + 4)^2$?

The square shown has dimensions $(x + 4)$ by $(x + 4)$ or $(x + 4)^2$

Let's look at an expanded form: $f(x) = x^2 + 8x + 10$

Try to arrange this set of tiles into a PERFECT SQUARE.

This arrangement, as is, will not fit into a perfect square. There will be a gap.

What problems are you running into? What could be done to remedy this situation?

If I were to allow you extra tiles, what would you need? Or would you rather take some away?

We need four extra tiles in order to complete our square.

If you ignored for the time being all your “ones” how many ones would you need to make a PERFECT SQUARE?

In order to make $8x$ into a perfect square, you would need 16 ones in total.

How could we keep this net gain at zero?

You can add or take away anything as long as you keep balance. For example putting $+16$ into equation is ok ONLY if you put -16 in as well. $16 + -16 = 0$.

The vertex form of this quadratic is $f(x) = (x + 4)^2 - 6$. Explain how this process helped me arrive at the vertex form.

Starting with this arrangement:

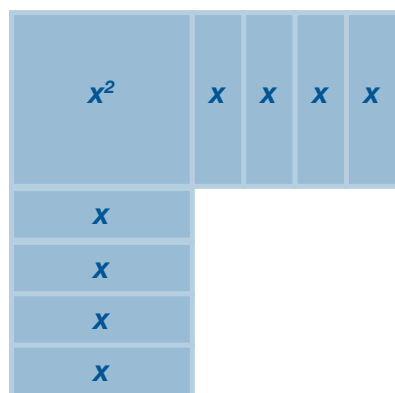

Notice none of the original ones were included. There's $+10$ of them. I realize I need 16 ones, therefore I am going to bring in 16 ones and -16 to counteract and keep balance. I can use the 16 positive tiles and now I have $(x + 4)^2 + 10 - 16$. The $+10$ represents the 10 original ones I have laying out to the side. The -16 is the additional ones I brought in for balance.

Therefore, my simplified expression is $(x + 4)^2 - 6$

Method 2 – Area Model (Algebra tiles generalized): Teacher Solutions

The squared expression $(x + 4)^2$ is represented geometrically to the right. Explain/make sense of this model.

This representation simply generalizes the pattern revealed in algebra tiles. Rather than representing 4 as four individual ones, this area model makes use of repeated reasoning and lumps all of the ones into 4.

	x	4
x	x^2	4x
4	4x	16

Let's try to reverse the process. Say I am building a PERFECT SQUARE and have the following. In each case, decide what it is I need to add on to have a completely perfect square. Draw an area model to illustrate your thought process.

(Area model pictures are not included but students should construct a model for each).

- a) $x^2 - 8x$
Needs +16 to make a square.
- b) $x^2 - 10x$
Needs +25 to make a square.
- c) $x^2 - 3x$
Needs +2.25 to make a square.
- d) $x^2 + 14x$
Needs +49 to make a square.
- e) $x^2 + 5x$
Needs +6.25 to make a square.

Now, what if I have $x^2 + 6x - 10$ and I would like to write it in vertex form. First I need a perfect square. Ignore the -10 and figure out what it is I need to complete my perfect square with $x^2 + 6x$.

+9 is needed.

How can you keep balance with what you have added to the problem?

Bring in +9 and -9 to keep balance.

Write $x^2 + 6x - 10$ in vertex form.

$$(x + 3)^2 - 9 - 10$$

$$(x + 3)^2 - 19$$

Evaluate Understanding

Use class evaluations of marshmallow data at end to assess students understanding of vertex form. In addition, an exit ticket may be helpful in understanding if students understand the process of completing the square. Questions should be asked of the process and procedure and not be strictly algebraic manipulations. It is important that they actually realize “what they are doing” in the process of completing the square.

Closing Activity



Compile your groups report regarding the flight of your marshmallow. All four areas of representation (equations, graph, words and tables) must be addressed and must correlate with one another. Put all these pieces together.

Independent Practice:

INCLUDED IN THE STUDENT MANUAL

Task #13: Practice Vertex Form/Complete the Square

Write the following quadratics in vertex-form and give the vertex of the quadratic:

1) $f(x) = x^2 + 3x - 18$

2) $g(x) = x^2 + 2x - 120$

3) $h(x) = x^2 + 7x - 17$

4) $k(x) = x^2 + 9x + 20.25$

5) $s(x) = 4x^2 - 5x - 21$

6) $t(x) = 16x^2 + 9x + 20$

7) $f(x) = -2x^2 + 10x - 5$

8) $r(x) = -3x^2 - 5x + 2$

Resources/Instructional Materials Needed:

- Algebra Tiles OR Web-based Interactive Algebra Tiles
- Marshmallows
- Measuring Devices
- Timing Devices (Most cell phones have accurate timers on them)

Vertex Form/Completing the Square: Possible Solutions

Write the following quadratics in vertex-form and give the vertex of the quadratic:

1) $f(x) = x^2 + 3x - 18$
 $f(x) = (x + 1.5)^2 - 20.25$
vertex: (-1.5, -20.25)

2) $g(x) = x^2 + 2x - 120$
 $g(x) = (x + 1)^2 - 121$
vertex: (-1, -121)

3) $h(x) = x^2 + 7x - 17$
 $h(x) = (x + 3.5)^2 - 29.25$
vertex: (-3.5, -29.25)

4) $k(x) = x^2 + 9x + 20.25$
 $k(x) = (x + 4.5)^2$
vertex: (-4.5, 0)

5) $s(x) = 4x^2 - 5x - 21$
 $s(x) = 4(x - 0.625)^2 - 22.5625$
vertex: (0.625, -22.5625)

6) $t(x) = 16x^2 + 9x + 20$
 $t(x) = 16(x + 0.28125)^2 + 18.734375$
vertex: (-0.28125, 18.734375)

7) $f(x) = -2x^2 + 10x - 5$
 $f(x) = -2(x - 2.5)^2 + 7.5$
vertex: (2.5, 7.5)

8) $r(x) = -3x^2 - 5x + 2$
 $r(x) = -3(x + \frac{5}{6})^2 + \frac{49}{12}$
vertex: $(-\frac{5}{6}, \frac{49}{12})$

Practice for Lesson 6 Vertex Form/Completing the Square: Possible Solutions

- What value is required to complete the square?
 - $x^2 + 20x + 100$
 - $x^2 - 7x + 12.25$
 - $x^2 - 4x + 4$
- Convert each quadratic function to vertex form AND find the coordinates of the max/min point on its graph.
 - $a(x) = x^2 + 12x + 11$
 $a(x) = (x + 6)^2 - 25$
 min: **(-6, -25)**
 - $b(x) = x^2 - 4x + 7$
 $b(x) = (x - 2)^2 + 3$
 min: **(2, 3)**
 - $c(x) = x^2 - 18x + 74$
 $c(x) = (x - 9)^2 - 7$
 min: **(9, -7)**
 - $d(x) = x^2 - 2x - 48$
 $d(x) = (x - 1)^2 - 49$
 min: **(1, -49)**
 - $g(x) = x^2 - 2x - 8$
 $g(x) = (x - 1)^2 - 9$
 min: **(1, -9)**
 - $f(x) = x^2 + 12x + 20$
 $f(x) = (x + 6)^2 - 16$
 min: **(-6, -16)**
- For each of the functions you may use any method you choose to record the information in the table.

Function	x-intercepts	y-intercept	Max or min?	Vertex
$a^2 - 2a - 8 = 0$	(-2, 0) (4, 0)	(0, -8)	Min	(1, -9)
$b^2 + 2b - 33 = 0$	(-6.83, 0) (4.83, 0)	(0, -33)	Min	(-1, -34)
$c^2 - 8c + 21 = 6$	(5, 0) (3, 0)	(0, 15)	Min	(4, -1)
$d^2 + 13d + 22 = 7$	(-11.72, 0) (-1.28, 0)	(0, 15)	Min	(-6.5, -27.25)
$f^2 + 19f + 66 = 6$	(-15, 0) (-4, 0)	(0, 60)	Min	(-9.5, -30.25)

INCLUDED IN THE STUDENT MANUAL

Task #14: Extension Piper and Golden Gate Bridge

- Piper, the amazing golden retriever, likes to go exploring. Aiming to keep her home more, Stefanie has decided to fence in part of her yard. She purchased 500 feet of fencing at Lowes this weekend and plans to use the back side of her house as one side of the Piper-pen. Stefanie would like to fence in the largest possible area for Piper. Find the width and length that gives Piper the largest possible yard to play in.
- Use vertex form to prove that of all rectangles with a given perimeter, a square has the greatest area.
- The golden gate bridge spans 4,200 feet between towers. The towers supporting the cables are 500 feet high. Suppose the middle of the bridge is $(0,0)$. Write a function in vertex form to model the support cables on the Golden Gate Bridge. How high is the cable in the middle of the bridge?

Answer: Vertex is at $(125, 31250)$. Thus the pen should be 125 by 250 to maximize play space for Piper.

Quadratic Functions

Lesson 7 of 12

Transformations and Quadratic Functions

Description:

Students use technology to investigate the effects of changing the coefficient k in vertex form to the resulting graph.

Georgia Standards of Excellence Addressed:

- MGSE9-12.F.BF.3: Identify the effect on the graph of replacing $f(x)$ by $f(x) + k$, $k f(x)$, $f(kx)$, and $f(x + k)$ for specific values of k (both positive and negative); find the value of k given the graphs. Experiment with cases and illustrate an explanation of the effects on the graph using technology. Include recognizing even and odd functions from their graphs and algebraic expressions for them.

Standard(s) for Mathematical Practice Emphasized:

- SMP 5: Use appropriate tools strategically.

Sequence of Instruction

Activities Checklist

Engage



Explain that our study of quadratics has included the vertex form of a parabola: $y = a(x - h)^2 + k$. The letters a , h , and k each serve a purpose and affect the “look” of the graph of the parabola.

The next activity will help students discover the powers of a , h , and k in an interactive activity. According to Shodor, developers, the Conic Flyer “allows the user to explore the effect of changing the constants in the equations of the graphs of parabolas.”

Have each student open this webpage on a computer or Ipad:

www.Shodor.org/interactivate/activities/conicflyer

Note: At the time of development, Desmos was not available. The directions that follow are specific to the Shodor applet; however, Desmos has similar capabilities and may be easily substituted.

Explore



Instructions to Students:

1. In the drop-down menu, change the shape being studied to “vertical parabola.”
2. Choose “Light Grid Lines.”
3. Note that the given equation under the graph uses the color purple for the “ a ” value, red for the “ h ” value, and blue for the “ k ” value for a parabola that opens up or down and whose equation is in vertex form.

- Experiment with each of the colored sliders one at a time by moving the slider right or left. Then change more than one slider at a time to discover the effects to the graph. Choose “Reset Sliders” to reset to the original values.

Explanation

Takes place during practice together.



INCLUDED IN THE STUDENT MANUAL

Task #15: Conic Flyer

Describe in general terms how each parameter (slider) changes the graph:

- Purple
 - Red
 - Blue
- Which of these parameters affects the range of each parabolic function? Explain.
 - The equation $y = 1(x - 0)^2 + 0$ or $y = x^2$ is considered the “parent” function for a vertical parabola. Find five points on the graph of $y = x^2$ and list them below.
 - Fold a sheet of graph paper into fourths, and draw a pair of y - and x - axes in each. Use your five values to graph $y = x^2$ in each fourth of the sheet. First predict how the graph of $y = x^2$ would change for each of the following and then sketch each on the graph paper (without substituting any points for the new equations below).
 - $y = (x - 2)^2 + 4$
 - $y = -(x + 3)^2 - 1$
 - $y = 3(x + 1)^2 - 2$
 - $y = -\frac{1}{3}(x + 1)^2 - 2$
 - Determine the range of each function above.

Practice Together / in Small Groups / Individually

Using technology appropriately, students should be able to discuss the following questions. Students should play with the Shodor application or Desmos Online Calculator and be asked to generalize results.

Possible Solutions

Describe in general terms how each parameter (slider) changes the graph:

- Purple (**determines the direction of opening and width**).
 - Red (**shifts the graph right or left**).
 - Blue (**shifts the graph up or down**).
- Which of these parameters affects the range of each parabolic function? Explain.
The third slider, k , moves the graph up or down and so changes the maximum or minimum y -values in the range.
 - The equation $y = 1(x - 0)^2 + 0$ or $y = x^2$ is considered the “parent” function for a vertical parabola. Find five points on the graph of $y = x^2$ and list them below.

(0,0), (1,1), (-1,1), (2,4), (-2,4), (3,9), (-3,9), (4, 16), (-4,16) are a few examples.

3. Fold a sheet of graph paper into fourths, and draw a pair of y- and x- axes in each. Use your five values to graph $y = x^2$ in each fourth of the sheet. First predict how the graph of $y = x^2$ would change for each of the following and then sketch each on the graph paper (without substituting any points for the new equations below).
- (a) $y = (x - 2)^2 + 4$
shifts graph of $y = x^2$ right two units and up four units, opens up.
- (b) $y = -(x + 3)^2 - 1$
shifts graph of $y = x^2$ left three units, down 1, opens down.
- (c) $y = 3(x + 1)^2 - 2$
shifts graph of $y = x^2$ left one unit, down two units, narrower, opens up.
- (d) $y = -\frac{1}{3}(x + 1)^2 - 2$
shifts graph of $y = x^2$ left one unit, down two units, wider, opens down.
4. Determine the range of each function above.
- (a) $y \geq 4$
- (b) $y \leq -1$
- (c) $y \geq -2$
- (d) $y \leq -2$

Closing Activity

To assess mastery, have the entire class play a game of “Concentration.” From a playing board of 16 squares, students will uncover and eventually match equations in vertex form with their corresponding transformations/range values. The winner is the student who makes the most correct matches. The name of each next player should be chosen randomly and this helps insure that all students are engaged until the end of the game.

A sample of a Concentration Game that can be used on the overhead or document camera is included. The “squares” can be changed to include eight parabolic equations and their corresponding transformations/ranges. Small Post-It notes can be used to quickly cover and uncover the squares as the game is played.

Independent Practice:

As an extension and in an outside assignment, each student may be asked to create a new playing board for the Concentration game by choosing eight new parabolic equations in vertex form **and drawing their corresponding graphs**. The new equations and matching graphs can be exchanged and then checked by a partner for accuracy.

Resources/Instructional Materials Needed:

- Computers with Internet Access (for Shodor.org or Desmos.org)
- Concentration Game Handout (Provided in handouts)

Concentration Game

Brief Idea of the Game:

The North Carolina Early Mathematics Placement Testing (NC EMPT) Concentration Game offers a fast-paced and fun classroom activity that has minimal preparation time and can be completed within 15-20 minutes. There are four versions of the game available at this time, each of which concentrates on various algebra skills required for success on college-level mathematics placement tests. Version (1) is titled “Fractions, Functions, and Factoring,” Version (2) is called “Solve, Solve, and Solve Some More,” Version (3) is titled “Exponents and Radicals,” and Version (4) is “Toe That Line!” All four versions offer excellent practice and reinforcement of important algebra skills for high school students enrolled in Algebra II, Integrated Math III, Advanced Functions and Modeling, Pre-Calculus, Discrete Math, Statistics, and other upper-level math courses. For incoming college freshmen, careful preparation and a realistic view of readiness are the keys to success on math placement exams and the resulting placement in a beginning level college math course.

Teacher Prep for the Game:

Make an overhead transparency of each game board by first opening the Word files and printing copies of one or all of the “NC EMPT Concentration Games.” Cover the contents of each of the sixteen rectangular spaces on each transparency film with a 2" x 1.5" post-it note. Since the transparency film is often “slick”, use a small piece of clear tape on the top of each note to better adhere it to the transparency. Each version of the game board has a random assortment of eight questions and eight corresponding answers.

Student Prep for the Game:

Each student should fold a piece of loose-leaf paper or a plain 8.5" x 11" sheet of paper to duplicate the transparency game board. To do this, fold each sheet twice vertically and twice horizontally so that when the paper is unfolded there will be fold lines for four columns and four rows. See the sample below. Have each student label each row and column as is done on each transparency:

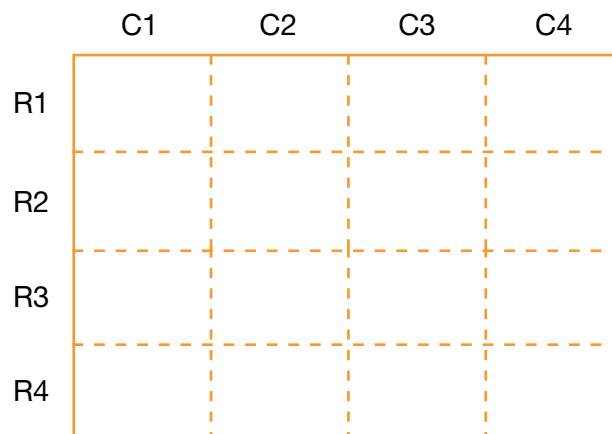

To help decide which students are selected to play and the order of play, each student in the class should be given a small card with an integer written on it, such as one to 30. Prior to the beginning of the game, these cards should be collected in a basket and

the basket assigned to a student who will randomly pick a card during play when asked by the teacher. The player with the number selected gets a turn. Cards should be returned to the basket after each selection that is drawn “with replacement,” so that no student will discontinue play too early. To encourage all students to work all eight problems on the game board, the teacher may require that each student show their work for each question in the appropriate rectangular box on their paper game board and then turn in the completed game board at the end of the game.

The teacher should choose a second student to serve as a scorekeeper throughout the game. The scorekeeper records the name of each player that successfully matches a question to its answer. Each correct match earns the player one point.

Rules of the Game:

The object of the game is to correctly match as many of the algebra questions with their correct answers. If a student makes a correct match, then he earns another turn to play. The winner is the student who makes the most correct matches.

To begin play, a card is drawn from the basket and the student assigned that number has the first turn. Player one calls out the position of the two rectangular boxes that he wants uncovered on the overhead transparency. The locations of the two boxes are determined by their row and column numbers. For example, the student might call out “R1,C4. and R3,C2.” The teacher uncovers the contents of each of these boxes by lifting up the corresponding post-it notes. All students in the class are encouraged to write down the newly revealed questions and/or answers in the corresponding boxes on their paper game boards because this information will be very helpful during the remainder of the game. If Player one makes a match, then the teacher removes these two post-it notes from the transparency sheet and Player one earns another turn. Player one continues until an incorrect match is made. In the case of an incorrect match, the teacher recovers the two incorrect choices by pressing down the corresponding post-it notes, another card is selected from the basket to determine Player two, and play resumes. When all eight algebra questions have been correctly matched with their answers, the game is over. The winner is the student that has the highest number of correct matches. (The beauty of using post-it notes is that they stay adhered and can easily be lifted up and down during play. They are only removed from the transparency when a match is made.)

As another option, each student can be given a copy of the game board, be directed to cut out the sixteen rectangles, and then paste or tape each question next to the answer they think is correct on loose-leaf paper. Work should still be shown for each of the eight pairs.

Answer Key:

An answer key for this version of the game is provided below. Note that in order for the teacher to quickly know if a correct match is made, corresponding geometric shapes from the key can be lightly penciled in on the top of each post-it note. If using a transparency, these shapes will not be visible to students during the game, but two matching shapes will quickly tell the teacher if a correct match has been made.

Transformations & Quadratic Functions Key:

Created by Ellen Hilgoe, Associate Director, NC Early Mathematics Placement Testing Program – providing a reality check of readiness for college-level mathematics. Visit us at www.ncemp.com.

Concentration Game – Transformations & Quadratics

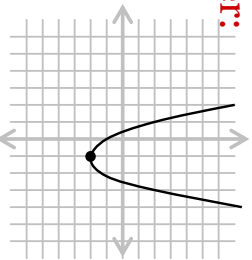
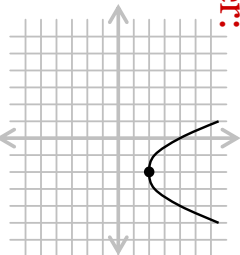
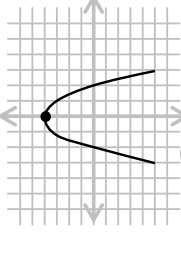
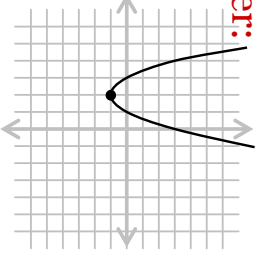
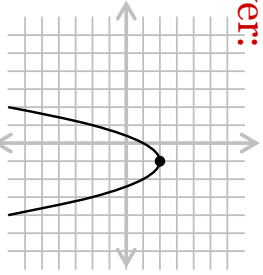
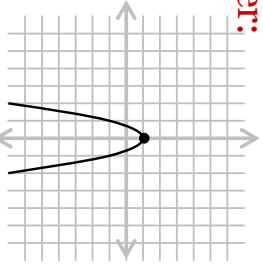
	C 1	C 2	C 3	C 4
R 1	<p>Answer:</p> 	<p>Answer: range is $y \leq 0$</p>	<p>Answer:</p> 	<p>Question: Find the range of: $y = x^2$</p>
R 2	<p>Question: Find the range of:</p> 	<p>Question: Graph: $y = -2x^2 + 1$</p>	<p>Answer: range is $y \geq 0$</p>	<p>Question: Graph: $y = (x + 2)^2 - 1$</p>
R 3	<p>Answer:</p> 	<p>Question: Graph: $y = -(x - 1)^2 + 2$</p>	<p>Answer: range is $y \geq -4$</p>	<p>Question: Find the range of: $y = -x^2$</p>
R 4	<p>Question: Graph: $y = \frac{1}{2}(x - 2)^2 + 2$</p>	<p>Answer:</p> 	<p>Question: Graph: $y = (x - 1)^2 - 2$</p>	<p>Answer:</p> 

North Carolina Early Mathematics Placement Testing ... a reality check of readiness for college-level mathematics.

Quadratic Functions

Lesson 8 of 12

Solving Quadratics

Description:

This lesson concentrates on what it “means” to solve a quadratic and explores a graphical and tabular approach first. Students make connections to the terminology of solving, roots, and x-intercepts.

Georgia Standards of Excellence Addressed:

- MGSE9-12.A.REI.4: Solve quadratic equations in one variable.
- MGSE9-12.A.REI.4a: Use the method of completing the square to transform any quadratic equation in x into an equation of the form $(x - p)^2 = q$ that has the same solutions. Derive the quadratic formula from $ax^2 + bx + c = 0$.
- MGSE9-12.A.REI.4b: Solve quadratic equations by inspection (e.g., for $x^2 = 49$), taking square roots, factoring, completing the square, and the quadratic formula, as appropriate to the initial form of the equation (limit to real number solutions).
- MGSE9-12.F.IF.4: Using tables, graphs, and verbal descriptions, interpret the key characteristics of a function which models the relationship between two quantities. Sketch a graph showing key features including: intercepts; interval where the function is increasing, decreasing, positive, or negative; relative maximums and minimums; symmetries; end behavior; and periodicity.
- MGSE9-12.F.IF.9: Compare properties of two functions each represented in a different way (algebraically, graphically, numerically in tables, or by verbal descriptions). For example, given a graph of one function and an algebraic expression for another, say which has the larger maximum.

Standard(s) for Mathematical Practice Emphasized:

- SMP 2: Reason abstractly and quantitatively.
- SMP 3: Construct viable arguments and critique the reasoning of others.
- SMP 6: Attend to precision.

Sequence of
Instruction

Activities Checklist

Engage



A note on solving quadratics. This topic is broken into three lessons (8, 9 and 10) as follows: Introduction to solving, algebraic manipulation solving methods (including factoring, completing the square and square roots), and the quadratic formula. The intent of this first lesson is to conceptually develop what “solving” a quadratic means focusing specifically on use of a table and/or graph.

INCLUDED IN THE STUDENT MANUAL

Task #16: Solving Quadratics

Using any method you choose, solve the following equations.

1. $3x + 7 = 5$
2. $3x^2 - 5 = 7$
3. $x^2 + 42x - 9 = 0$
4. $3x^2 + 15x - 6 = 0$

Have students share their method of arriving at a correct answer. Ask students to justify their choice. If students solve using a variety of methods make sure to highlight the different approaches through class discussion. The following questions should be posed as an exploration (do not search for or give the correct answers at this point as the lesson will develop this).

What does it mean to solve a quadratic, what were you looking for?

Did anyone approach it graphically? Explain.

Did anyone play guess and check? Explain.

Did anyone use the table on your calculator? What were you looking for?

Did anyone use algebraic manipulation skills? Explain.

How is solving a quadratic equation (like those above) similar to and different from solving a linear equation like $4x + 5 = 17$?

In other words, we found the solutions to the equation or the values of x that made the equation true. Consider the popular game of Angry Birds and (show graphic of angry birds) have students reason abstractly and quantitatively as a class using the following questions as discussion prompters.

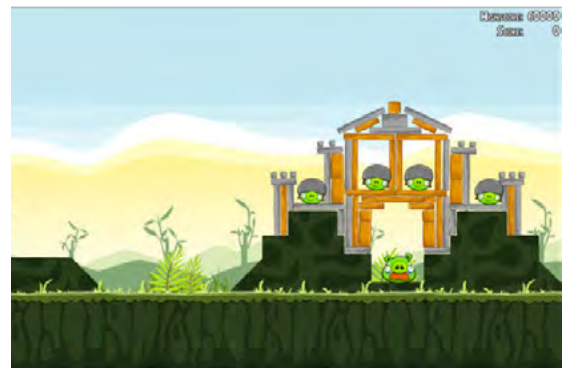

Assuming we know that the equation of one possible bird flight pattern of our bird is $h(t) = 48 + 32t - 16t^2$ where h represents the height of the bird in feet and t is the time bird has been in flight travelled, what information would we find by solving $0 = 48 + 32t - 16t^2$. Would this equation be helpful in determining if we were going to hit one of the pigs, why or why not? (This equation for projectile motion is not helpful in determining if we hit a pig at the end. The equation could tell us if we hit a pig that was in the air that coincided with the path of the bird. The function $h(t)$ shows us the pigs height off the ground at time t due to the effects of gravity on a projectile motion.) What equation would we need to solve if we knew one of the pigs is eight feet in the air? How is this quadratic equation different from the ones you solved previously? Can we solve this equation algebraically? Could we use a table to answer this question? A graph? (Change the value 8 as necessary to make sure students get the point.)

Explore



Solve: $0 = 48 + 32t - 16t^2$. What does the solution of this expression tell you in terms of the flight of a bird? How many solutions did you find? If you found more than one solution, are all of them feasible? (That is are all solutions realistic in terms of the angry bird flight plan. Make sure students understand the difference in answers contextually and are able to understand the limitations of fitting a decontextualized function to a contextual setting.)

- Now enter the equation into $y=$ and find the x -intercepts on the graph. What do you notice about the x -intercepts in comparison to your solutions found in part a?
- Now look at the table. Remember that our y values represent the height of our bird. Scan the table until you find the instance(s) when the height is zero. What do you notice about these x -values?

As we know, many of pigs are not at ground level so we are forced to solve equations that are not equal to zero. Consider again the equation that we wrote in the launch:
 $8 = 48 + 32t - 16t^2$

- How does this equation help us if we have a target pig 8 feet in the air? To solve a quadratic equation by hand, we must have the equation set equal to zero. How can we transform this equation so that it is equal to zero? Do you notice any common factors? What could we do with these? Why? If students continue to struggle the following questions are more direct: Does our new equation have a greatest common factor? If so, what is it? Can we factor this equation more so that we can solve it?
- Sometimes quadratic equations are not easy to factor so we can use technology to approximate the solutions. Since we were not able to find exact solutions by factoring, we can use tables and graphs to approximate the solutions. Enter each side of the equation into y_1 and y_2 . Keeping in mind that these are the two sides of the equation, what should we look for on the graph? What about in the table? What are the approximate solutions? How many solutions are there? If there is more than one, are all of them feasible?

What if the pig was at a height of 64 feet instead of eight feet? Would it be possible to hit him? What equation would be associated with this scenario? How many solutions are there to this equation?

Could you hit a pig if it were at a height of 70 feet? Why or why not?

Explanation



1. Describe the process used to solve an equation of the form.

$$ax^2 + bx + c = d$$

$$ax^2 + bx + c = dx + f$$

$$ax^2 + bx + c = dx^2 + fx + g$$

The later two examples may be too great of a jump for some students. Monitor class ability and if necessary have students do similar problems but with numbers instead of a literal example first. It is important that students are able to generalize the pattern in solving various forms of quadratic expressions.

How many solutions are possible when solving an equation of the form $ax^2 + bx + c = d$? Are all solutions necessarily feasible? Explain.

Practice Together / in Small Groups / Individually



For students:

INCLUDED IN THE STUDENT MANUAL

Task #17: Angry Birds

An angry bird's flight path is given by the equation $h(t) = 45 + 25t - 16t^2$. As a group, use this information and construct viable arguments for the following claims.

Are pigs at heights of 45, 57, and 65 a hit or not?

If we can hit the pigs, determine how long it will take to hit each one?

Can all three pigs be hit on the same trajectory? Explain?

(Teacher note: This question is contextualizing the situation as after a pig has hit a target it can no longer continue on the path due to the nature of the game.)

In the game of angry birds, you can't control the height of the slingshot or the effect of gravity, but you can change how far back and to what angle you pull on the slingshot to fire the bird. This manipulation would directly affect the initial velocity of the bird. In our original equation the velocity was 25. If you did not hit one of the pigs at 45, 57, or 65, manipulate the value of b (to signify changing the slingshot fire) to see if you could hit one of the pigs. Provide a justified conclusion of your findings.

Evaluate Understanding

Evaluate the small group activity for understanding of solving quadratic equations.

Closing Activity



Individually students should come up with many justified ways to solve this task.

INCLUDED IN THE STUDENT MANUAL

Task #18: Two Squares

Solve the quadratic equation using as many different methods as possible.

$$x^2 = (2x - 9)^2$$

<http://www.illustrativemathematics.org/illustrations/618>

Independent Practice

INCLUDED IN THE STUDENT MANUAL

Task #19: Solving Quadratic Functions with tables and graphs

Some highway patrol officers use the formula $d=0.05s^2 + 1.1s$ to predict (or sometimes analyze) stopping distance, d , for speeds, s . For the following equations, find the solution and explain what each says about stopping distance.

a) $180 = 0.05s^2 + 1.1s$

b) $95 = 0.05s^2 + 1.1s$

c) $d = 0.05(45)^2 + 1.1(45)$

d) $d = 0.05(60)^2 + 1.1(60)$

The height of a football, in feet, kicked from the ground at time, t , in seconds, can be estimated by the equation $h(t) = 35t - 16t^2$.

- Write and solve an equation to show when the football hits the ground at the end of its flight.
- Regulation for high school, NCAA and the NFL require the goal post to be 10 feet above the ground. At what times is the ball 10 feet or higher above the ground? Show your work.

Solving Quadratic Functions with Tables and Graphs: Possible Solutions

Some highway patrol officers use the formula $d = 0.05s^2 + 1.1s$ to predict (or sometimes analyze) stopping distance, d , for speeds, s . For the following equations, find the solution and explain what each says about stopping distance.

a. $180 = 0.05s^2 + 1.1s$

If it took 180 units to stop, how fast was the car traveling? (Speed of 50)

b. $95 = 0.05s^2 + 1.1s$

If it took 95 units to stop, how fast was the car traveling? (34)

c. $d = 0.05(45)^2 + 1.1(45)$

How far will it take to stop when traveling 45? (150.75)

d. $d = 0.05(60)^2 + 1.1(60)$

How far will it take to stop when traveling 60? (246)

The height of a football, in feet, kicked from the ground at time, t , in seconds, can be estimated by the equation $h(t) = 35t - 16t^2$.

- Write and solve an equation to show when the football hits the ground at the end of its flight.

$0 = 35t - 16t^2$ The football hits the ground somewhere around 2.19 seconds after being kicked.

Quadratic Functions

Lesson 9 of 12

Solving Quadratics: Comparing Methods

Description:

Knowing what to do with the structure of each form of quadratic leads to strategic competence in efficiently solving quadratic equations. This investigation focuses on choosing the most appropriate method.

Georgia Standards of Excellence Addressed:

- MGSE9-12.A.REI.4: Solve quadratic equations in one variable.
- MGSE9-12.A.REI.4a: Use the method of completing the square to transform any quadratic equation in x into an equation of the form $(x - p)^2 = q$ that has the same solutions. Derive the quadratic formula from $ax^2 + bx + c = 0$.
- MGSE9-12.A.REI.4b: Solve quadratic equations by inspection (e.g., for $x^2 = 49$), taking square roots, factoring, completing the square, and the quadratic formula, as appropriate to the initial form of the equation (limit to real number solutions).
- MGSE9-12.F.IF.4: Using tables, graphs, and verbal descriptions, interpret the key characteristics of a function which models the relationship between two quantities. Sketch a graph showing key features including: intercepts; interval where the function is increasing, decreasing, positive, or negative; relative maximums and minimums; symmetries; end behavior; and periodicity.
- MGSE9-12.F.IF.9: Compare properties of two functions each represented in a different way (algebraically, graphically, numerically in tables, or by verbal descriptions). For example, given a graph of one function and an algebraic expression for another, say which has the larger maximum.

Standard(s) for Mathematical Practice Emphasized:

- SMP 1: Make sense of problems and persevere in solving them.
- SMP 3: Construct viable arguments and critique the reasoning of others.
- SMP 6: Attend to precision.

Sequence of
Instruction

Activities Checklist

Engage



INCLUDED IN THE STUDENT MANUAL

Task #20: Solve the following quadratic equations using the method(s) of your choice.

Show all work to make sure others can follow your approach.

1. $3(x - 4)^2 - 2 = 25$
2. $(6x + 5)(2x - 1) = 0$
3. $9x^2 + 4.7x - 6 = 0$

After students have had ample time to complete the activity individually, discuss the following questions:

Did you solve the three problems differently? If so, how did you make the decision to solve the equation the way you did? Did the form that the equation was in determine your choice? How do you think you could convince someone that your method is best? Did you use algebraic methods or did you use technology to help you come up with your solutions? Are all of your answers exact?

Explore



Solve $3(x - 4)^2 - 2 = 25$ algebraically if you have not already done so.

Did your process involve taking a square root or did you expand the binomial? Did you consider the other option? Now try solving the equation using the alternate method and compare your answers. Were both methods effective in arriving at the correct solution?

Which of the two algebraic methods was easier? Why? What are the benefits of solving this equation algebraically (as opposed to an estimation using a table or graph?)

Question #2 is in factored form. Solve $(6x + 5)(2x - 1) = 0$ algebraically if you have not already done so.

What would you have to do differently if the equation was set equal to -6 instead of zero?

Would you still choose to solve the equation algebraically? Why or why not?

Question #3 is in standard form and does not appear to be a quadratic that is factorable. Since we cannot factor this quadratic, we must use technology to approximate our solutions. (You will learn how to find exact solutions to all quadratics in the next lesson.) Look at the graph of

$$y = 9x^2 + 4.7x - 6$$

Since our equation is equal to 0, where should we look at the graph to find the solutions? What is another name for these points on the graph?

How could you use technology to solve $9x^2 + 4.7x - 1 = -6$? What do you notice about the values in the table?

What happens when you look at the graph?

You were asked to solve three different equations in the warm up. One student referred to their answer to #1 as **roots**, to #2 as **solutions**, and to #3 as **x-intercepts**. Why do you think they chose each of these words for each problem? Are they all correct?

Do all quadratic equations have roots/solutions/x-intercepts? Consider again the equation $(6x + 5)(2x - 1) = -6$. When looking at the graph, what do you notice? Does this equation have a solution?

The equation below is similar to #1.

At this point, formatively assess the needs of the class. Additional problems may be explored here if necessary.

You probably stated that there was “no solution” to the above question. There are actually solutions but they are called imaginary roots/solutions.

Why do you think they are not referred to as x-intercepts? (You will learn how to find imaginary roots/solutions in the next lesson.)

Explanation



1. Describe the process you would use to solve an equation of the form $a(x + d)^2 + c = d$. Justify your choice with and discuss the level of accuracy possible with your solving method.
2. Describe the process you would use to solve an equation of the form $(x + a)(x - b) = 0$ and why. What would you do differently if the equation were set equal to a number other than zero?
3. Describe the process you would use to solve an equation of the form $ax^2 + bx + c = d$ and why. What if the equation was not factorable? Would you solve the equation differently if it was set equal to a number other than zero?
4. Is there a difference between finding the roots/solutions/x-intercepts of a quadratic equation? Communicate precisely your rationale.
5. How do you know if there are no real solutions to a quadratic equation solved algebraically? Graphically?

Practice Together / in Small Groups / Individually

Solve the following quadratic equations. Show work or explain how you came up with your answer. If no solution exists, explain why.

1. $2(x - 5)^2 + 9 = 31$
2. $(7x - 4)(3x + 8) = 0$
3. $-5x^2 + 5.3x - 2.4 = 0$

Evaluate Understanding



Monitor group work and individual performance.

Solving methods quiz—evaluating others approaches included in the student manual.

Quadratic Functions

Lesson 10 of 12

Generalizing Solving: The Quadratic Formula

Description:

The quadratic formula is a way to express repeated reasoning of solving quadratics in vertex form. Students explore this pattern and arrive at the quadratic formula.

Georgia Standards of Excellence Addressed:

- MGSE9-12-A.SSE.2: Use the structure of an expression to rewrite it in different equivalent forms. For example, see $x^4 - y^4$ as $(x^2)^2 - (y^2)^2$, thus recognizing it as a difference of squares that can be factored as $(x^2 - y^2)(x^2 + y^2)$.
- AMGSE9-12.A.REI.4: Solve quadratic equations in one variable.
- MGSE9-12.A.REI.4a: Use the method of completing the square to transform any quadratic equation in x into an equation of the form $(x - p)^2 = q$ that has the same solutions. Derive the quadratic formula from $ax^2 + bx + c = 0$.
- MGSE9-12.A.REI.4b: Solve quadratic equations by inspection (e.g., for $x^2 = 49$), taking square roots, factoring, completing the square, and the quadratic formula, as appropriate to the initial form of the equation (limit to real number solutions).

Standard(s) for Mathematical Practice Emphasized:

- SMP 1: Make sense of problems and persevere in solving them.
- SMP 8: Look for and express regularity in repeated reasoning.

Sequence of
Instruction

Activities Checklist

Engage

MATH
1
PRACTICE

INCLUDED IN THE STUDENT MANUAL

Task #22: Formative Assessment/Introductory Activities

1. Draw, if possible, a quadratic function that has:
 - a. zero roots
 - b. one root
 - c. two roots
 - d. three roots
2. Solve $2(x + 3)^2 - 5 = 0$ without a calculator.
3. Solve $2x^2 + 12x - 13 = 0$ without a calculator. (If you can't do this, don't worry. We will get to it in this lesson but give it a try.)

Explore/Explanation



Through this exploration students will express regularity revealed from repeated solving of quadratic equations by first completing the square. Students will generalize the process to arrive at the quadratic formula.

INCLUDED IN THE STUDENT MANUAL

Task #23: Completing the Square to Quadratic Formula

The main body of the lesson:

Consider again $2x^2 + 12x - 13 = 0$. We will review how we can change the form of this equation to make it easier to solve.

- (a) Complete the missing step below:

$$\text{Note that } 2x^2 + 12x - 13 = 2(x^2 + \underline{\hspace{2cm}}) - 13$$

- (b) Which of the following choices is equal to $2(x^2 + 6x) - 13$

(i) $2(x^2 + 6x + 9) - 13$

(ii) $2(x^2 + 6x + 9) - 4$

(iii) $2(x^2 + 6x + 9) - 22$

(iv) $2(x^2 + 6x + 9) - 5$

- (c) Since $x^2 + 6x + 9 = (x + 3)^2$, use your answers to (a) and (b) above to complete the following sentence:

$$2x^2 + 12x - 13 = \underline{\hspace{2cm}}(x + 3)^2 - \underline{\hspace{2cm}}$$

- (d) Use your answer to (c) to solve $2x^2 + 12x - 13 = 0$ (Hint: you already did this)

We will now do something similar to develop the important and powerful Quadratic Formula, a formula that allows us to solve EVERY quadratic equation.

Suppose we need to solve the equation $ax^2 + bx + c = 0$ for x .

- (a) Complete the missing step below:

$$\text{Note that } ax^2 + bx + c = a(x^2 + \underline{\hspace{2cm}}) + c$$

- (b) Complete the missing step below:

$$a(x^2 + \frac{b}{a}x) + c = a(x^2 + \frac{b}{a}x + \frac{b^2}{4a^2}) + \underline{\hspace{2cm}}$$

- (c) Factor $x^2 + \frac{b}{a}x + \frac{b^2}{4a^2}$

- (d) Use your answers to (a), (b) and (c) above to complete the following sentence:

$$ax^2 + bx + c = a(x + \underline{\hspace{2cm}})^2 - \underline{\hspace{2cm}}$$

- (e) Use your answer to (d) to solve the equation $ax^2 + bx + c = 0$
(Hint: think about what you did to solve $2(x + 3)^2 - 5 = 0$).

Practice Together / in Small Groups / Individually



Students should generalize the process of completing the square as the quadratic formula. The graphic organizer will provide students with a connection of the quadratic formula to a quadratic graph. In groups, students should complete the toolkit and practice problems

INCLUDED IN THE STUDENT MANUAL

The Quadratic Formula

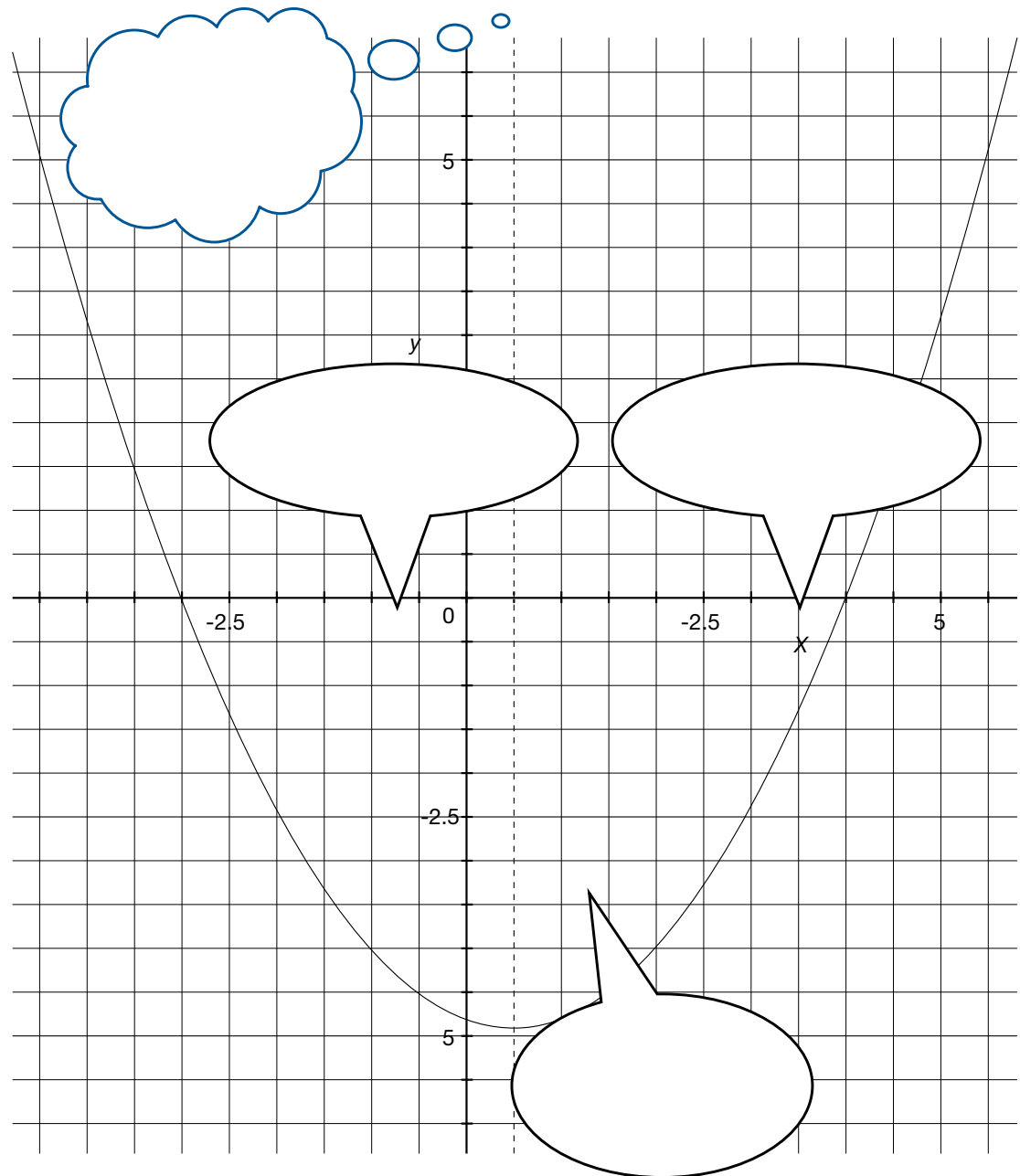

Quadratic Functions

Lesson 11 of 12

Systems of Equations with Quadratic Functions

Description:

This lesson provides an extension and connection from the systems unit already studied. Students look at systems of a line and parabola and two parabolas.

College Readiness Standards Addressed:

- MGSE9-12.A.REI.7: Solve a simple system consisting of a linear equation and a quadratic equation in two variables algebraically and graphically. For example, find the points of intersection between the line $y = -3x$ and the circle $x^2 + y^2 = 3$
- MGSE9-12.F.IF.4: Using tables, graphs, and verbal descriptions, interpret the key characteristics of a function which models the relationship between two quantities. Sketch a graph showing key features including: intercepts; interval where the function is increasing, decreasing, positive, or negative; relative maximums and minimums; symmetries; end behavior; and periodicity.
- MGSE9-12.F.IF.7: Graph functions expressed algebraically and show key features of the graph both by hand and by using technology.
- MGSE9-12.F.IF.7a: Graph linear and quadratic functions and show intercepts, maxima and minima (as determined by the function or by context).
- MGSE9-12.F.IF.9: Compare properties of two functions each represented in a different way (algebraically, graphically, numerically in tables, or by verbal descriptions). For example, given a graph of one function and an algebraic expression for another, say which has the larger maximum.

Standard(s) for Mathematical Practice Emphasized:

- SMP 1: Make sense of problems and persevere in solving them.
- SMP 3: Construct viable arguments and critique the reasoning of others. discourse.

Sequence of
Instruction

Activities Checklist

Engage

Begin class with a short, two-minute video (of four high school students demonstrating how to solve systems of equations and inequalities involving a line/parabola and a parabola/parabola). Tell students that they are to do no writing during this first viewing, but are to carefully watch.

Video link:

(<http://www.youtube.com/watch?v=aGM04mFlt0Q>.)

Explore



Then ask students the following questions and encourage a class discussion. Possible answers are shown in italics.

- What is the point of the lesson taught by the students in the video? *To show two methods of solving a system of two linear/quadratic equations or inequalities.*
- How many pairs of systems were presented? *Three, but the first and the third were the same pair solved two different ways.*
- How did the methods used to solve the systems on the videos compare to the methods you've already learned to solve a system of two linear equations? *Very similar—Method 1 was graphing and Method 2 was substitution, both of which are used with systems of two linear equations.*
- What is your opinion of the mathematical quality of the video? Did the students who made the video make any errors? *Yes. For example, they described the pair of inequalities as equations. They misspelled "Let's."*

If the class discussion stalls for any of the four questions above, *let it do so!* Announce to students that the video will be viewed for a second time. Repeat any of the four questions not thoroughly answered in the first discussion and ask students to search for the answers in the second viewing. Also ask students to write down the pairs of equations and inequalities solved in the video. Then show the video for a second time.

After the second viewing, encourage students to expand on the discussion of the answers to the four questions once again. Have students write the pairs of equations/inequalities on the board to insure that everyone has copied them correctly.

Practice Together / in Small Groups / Individually



Explain that prior to the creation of the video, a script was written. Each group is to prepare this script and it will be a documentation of their understanding of the graphing and substitution methods of solving systems of linear/quadratic equations or inequalities. All steps should be shown for the solution of the three systems demonstrated in the video. Accurate graphs are to be drawn on graph paper for the graphical solutions. Include tables of values on the graph paper for each equation or inequality and label solutions clearly. Graphing calculators may be used as tools and to check written graphs for accuracy. For algebraic solutions, students are to be sure to carefully show

all steps in an organized, easy-to-follow series of steps. Loose-leaf paper, PDF, Word file or an electronic tablet may be used to show this work. The teacher will move about the room to answer questions posed by the groups and to gauge whether or not the groups were able to include all the missing steps not seen in the video. Documentation should be turned in to the teacher for each group. The teacher will assess these outside of class at a later time and offer written comments during the next class.

While still in groups, students are asked to consider all the ways in which two parabolas can intersect in a plane. Students are asked to sketch a diagram for each possibility and to make a conjecture about the number of possible intersection points for two parabolas. To encourage precision with mathematical vocabulary, explain that each of their diagrams is a sketch of a possible graphical solution of a system of two quadratic equations. (*Answers: 0, 1, 2, 3, or 4 intersections.*) Explain that students should keep these possible outcomes in mind when solving the closing activity.

If time allows, have students trade scripts and critique the reasoning and accuracy of their peers. If students find flaws, they should carefully explain and correct the script.

Evaluate Understanding

Have students turn in a copy of the closing activity to use as a formative assessment if the concept was mastered.

Closing Activity

Pose this problem:



INCLUDED IN THE STUDENT MANUAL

Task #24: Rockets

Rockets were assembled from kits by members of an engineering club and were launched from the ground at the same time. The height y in feet of one rocket after t seconds is given by $y = -16t^2 + 150t + 5$. The height of the other rocket is given by $y = -16t^2 + 160t$. After how many seconds are the rockets at the same height? What is this height?

Solution: The intersection point of the two parabolas is (0.5 seconds, 76 feet).

As an out-of-class assignment, students are to provide evidence of the solution of the problem and answer the two questions with clear and precise mathematical language. A graphical or algebraic approach may be used.

Independent Practice:

INCLUDED IN THE STUDENT MANUAL

Task #25: Practice Problems Non-Linear Systems

For each system below:

a) Graph each system by hand. If an equation is linear, rewrite it in slope-intercept form first and use this to help graph the line. If an equation is quadratic, rewrite it in vertex form and use this to help graph the parabola. Show your work next to each graph.

b) Verify your results with a graphing utility.

$$1) \begin{cases} y = x^2 + 1 \\ y = 4x + 1 \end{cases}$$

$$2) \begin{cases} y - x = -1 \\ y = x^2 - 6x + 9 \end{cases}$$

$$3) \begin{cases} 3x - y = -2 \\ 2x^2 - y = 0 \end{cases}$$

$$4) \begin{cases} y = -1 \\ y = -2x^2 + 4x - 5 \end{cases}$$

Practice Problems Non-Linear Systems: Teacher Solutions

For each system below:

- a) Graph each system by hand. If an equation is linear, rewrite it in slope-intercept form first and use this to help graph the line. If an equation is quadratic, rewrite it in vertex form and use this to help graph the parabola. Show your work next to each graph.
- b) Verify your results with a graphing utility.

$$1) \begin{cases} y = x^2 + 1 \\ y = 4x + 1 \end{cases}$$

Answer: $\{(0, 1)(4, 17)\}$

$$2) \begin{cases} y - x = -1 \\ y = x^2 - 6x + 9 \end{cases}$$

Answer: $\{(5, 4)(2, 1)\}$

$$3) \begin{cases} 3x - y = -2 \\ 2x^2 - y = 0 \end{cases}$$

Answer: $\{(-\frac{1}{2}, \frac{1}{2})(2, 8)\}$

$$4) \begin{cases} y = -1 \\ y = -2x^2 + 4x - 5 \end{cases}$$

Answer: no solution

Resources/Instructional Materials Needed:

- YouTube Access (Or video stored prior to class)
- Projector and Speakers

Notes:

Quadratic Functions

Lesson 12 of 12

Capstone Project

Description:

This is a comprehensive project that addresses all quadratic functions and algebra standards in this unit as students are asked to return to the gummy bear launch. This time, however, the focus is on precision and modeling techniques in order for the class to arrive at one winner. Students will be given time to collect data and alter strategies before the class selects a unique winner.

Georgia Standards of Excellence Addressed:

All standards listed should be assessed through one of the three project/problem ideas listed.

Standard(s) for Mathematical Practice Emphasized:

- SMP 1: Make sense of problems and persevere in solving them.
- SMP 4: Model with mathematics.
- SMP 5: Use appropriate tools strategically.
- SMP 6: Attend to precision.

Sequence of
Instruction

Activities Checklist

INCLUDED IN THE STUDENT MANUAL

Task #26: Gummy Bear Shoot Off

Using a tongue depressor, rubber band and a gummy bear you will devise a contraption to “fire” your gummy bear. The object of this project is not in the design of your firing device but rather your mathematical analysis of the flight of your gummy bear. This competition is similar to the egg launch we looked at in Lesson 3. In fact, you may wish to reference the brainstorming ideas from that lesson.

You are to fire your gummy bear and collect all necessary data. As a group, you will prepare one report that must include careful mathematical analysis of your gummy bear including equations, graphs, tables and descriptions. Write AND answer questions about the flight of your gummy bear.

Your final project will be graded according to the rubric and evaluated for mathematical correctness and completion.

In your report include reflections on the following questions:

- Synthesize what you have learned in this unit. How did you incorporate those ideas into your mathematical analysis of your gummy bear?
- How do the different forms of a quadratic reveal different information about the flight of your gummy bear? In answering questions?

Topic	Not Yet	Getting There	Proficient	Highly Proficient
Tables and Graphs	Tables and graphs are missing or incomplete	Tables and graphs are present but contain mechanical flaws	Tables and graphs are present and correct	Tables and graphs are present and correct and are discussed and/or connected in other areas of the analysis.
Equations	Equations are incorrectly calculated	Equations show signs of correct thinking but flaws are present (in procedure or understanding)	Equations are correct and all work is shown how they were developed.	Equations are thorough and correct and connected to other areas of the analysis.
Analysis of Mathematics	Mathematical analysis contains flaws in conceptual understanding. Tables, graphs and equations are presented as three separate pieces and not tied together.	Mathematical analysis has gaps in understanding. Demonstrates a basic understanding but does not comprehend the interplay of tables, graphs, and equations.	Demonstrates understanding of the interplay of tables, graphs, and equations and can accurately describe the scenario in terms of all.	Exceeds proficient and demonstrates a solid foundation in analyzing a mathematical situation from all standpoints.
Questions in Regard to Flight	Ask two or fewer questions that are relevant and make sense to the data collected	Ask three questions but may not be relevant or make sense to the data	Ask three “good” questions that make sense to ask and are relevant to data	Ask in-depth questions that demonstrate a complex understanding of the concepts. Questions are well thought out and relevant.
Answers to Questions Asked	Did not answer questions correctly	Answered questions but incorrect thinking or contains mathematical flaws OR did not provide justification of answers (bald answers)	Answered questions correctly and provides justification	Answers are well documented and supported and display an in-depth understanding of the concept
Synthesis of Unit as a Whole	Project does not show overall mathematical understanding. Significant gaps in mathematics.	Project shows some understanding of math but disjointed. Information is spotty and incomplete	Project displays a cohesive, comprehensive understanding of quadratic functions. Ideas are connected and there are no mathematical flaws.	Project goes above and beyond and shows an in-depth complex understanding of analyzing quadratic functions.
Overall Cohesiveness of Project	Project is disjointed and put together in pieces	Some areas of project are disjointed – lacks clarity and/or focus	Project feels as “one” project. Pieces fit together and flow	Project is cohesive and complex and answers all questions in a non-list rather, comprehensive, manner

Evaluate Understanding

The following two problem solving lesson plans would be accessible to students following this unit. They would both serve as excellent assessments of the unit as a whole.

Tiling a Table –

<http://map.mathshell.org/materials/lessons.php?taskid=215&subpage=problem>

Cutting Corners –

<http://map.mathshell.org/materials/lessons.php?taskid=432&subpage=problem>

SREB Readiness Courses
Transitioning to college and careers

College Readiness Mathematics

Unit 6 . Quadratic Functions
Student Manual
Version 3

Name



Unit 6 . Quadratic Functions

Table of Contents

Lesson 1.....	4
Lesson 2.....	5
Lesson 3.....	9
Lesson 5.....	19
Lesson 6.....	23
Lesson 7.....	34
Lesson 8.....	36
Lesson 9.....	43
Lesson 10.....	44
Lesson 11.....	47
Lesson 12.....	50

Quadratics

Job Descriptor Cards

Reading Manager

- Reads ALL parts of the assignment and problems out loud to the group (others follow along).
- Ensures group members understand assignments.
- Keeps group focused on the task(s).

Spying Monitor

- Monitors group progress relative to other groups.
- Checks in with other groups for comparison.
- Only member in group that can talk/ask questions outside of group.

Quality Controller

- Ensures that all group members can EXPLAIN and JUSTIFY each response (random checks occur by management).
- Makes sure members are completing ALL problems in appropriate notebook.
- Keeps group supplies organized and neat.
- Reports missing items.

Recording Time Keeper

- Keeps track of time.
- When asked, shares group responses.
- Responsible for ensuring “public record” (posting of answers, group posters, etc.) is completed.

Task #2: The effect of a, b, and c

Answer the following equations for each function set. Each function set has four equations to explore.

Function Set 1

Equation 1: $f(x) = x^2 + 2x - 3$

Equation 2: $f(x) = -x^2 + 2x - 3$

Equation 3: $f(x) = 3x^2 + 2x - 3$

Equation 4: $f(x) = -3x^2 + 2x - 3$

What is different between equations 1 and 2?

What is different between equations 1 and 3?

What is different between equations 2 and 4?

What is different between equations 3 and 4?

What is the domain of the first function?

What is the domain of the second function?

What is the domain of the third function?

What is the domain of the fourth function?

Function Set 2

Equation 1: $f(x) = x^2 + 2x - 3$

Equation 2: $f(x) = -x^2 + 2x + 3$

Equation 3: $f(x) = x^2 + 2x + 3$

Equation 4: $f(x) = -x^2 + 2x - 3$

What is different between equations 1 and 2?

What is different between equations 1 and 3?

What is different between equations 2 and 4?

What is different between equations 3 and 4?

What is the domain of the first function?

What is the domain of the second function?

What is the domain of the third function?

What is the domain of the fourth function?

Function Set 3

Equation 1: $f(x) = x^2 + 2x - 3$

Equation 2: $f(x) = x^2 - 2x - 3$

Equation 3: $f(x) = 3x^2 + 2x - 3$

Equation 4: $f(x) = 3x^2 - 2x - 3$

What is different between equations 1 and 2?

What is different between equations 1 and 3?

What is different between equations 2 and 4?

What is different between equations 3 and 4?

What is the domain of the first function?

What is the domain of the second function?

What is the domain of the third function?

What is the domain of the fourth function?

Function Set 4

Equation 1: $f(x) = x^2 + 2x - 3$

Equation 2: $f(x) = 5x^2 + 2x + 5$

Equation 3: $f(x) = 3x^2 + 2x - 3$

Equation 4: $f(x) = -9x^2 + 2x + 4$

What is different between equations 1 and 2?

What is different between equations 1 and 3?

What is different between equations 2 and 4?

What is different between equations 3 and 4?

What is the domain of the first function?

What is the domain of the second function?

What is the domain of the third function?

What is the domain of the fourth function?

Task #3 Egg Launch Contest

Egg Launch Contest

NAME: _____

DATE: _____

Mr. Rhodes’ class is holding an egg launching contest on the football field. Teams of students have built catapults that will hurl an egg down the field. Ms. Monroe’s class will judge the contest. They have various tools and ideas for measuring each launch and how to determine which team wins.

Team A used their catapult and hurled an egg down the football field. Students used a motion detector to collect data while the egg was in the air. They came up with the table of data below.

DISTANCE FROM THE GOAL LINE (IN FEET)	HEIGHT (IN FEET)
7	19
12	90
14	101
19	90
21	55
24	0

Team B’s egg flew through the air and landed down the field. The group of students tracking the path of the egg determined that the equation $y = -0.8x^2 + 19x - 40$ represents the path the egg took through the air, where x is the distance from the goal line and y is the height of the egg from the ground. (Both measures are in feet.)

When **Team C** launched an egg with their catapult, some of the judges found that the graph to the right shows the path of the egg.

Which team do you think won the contest? Why?

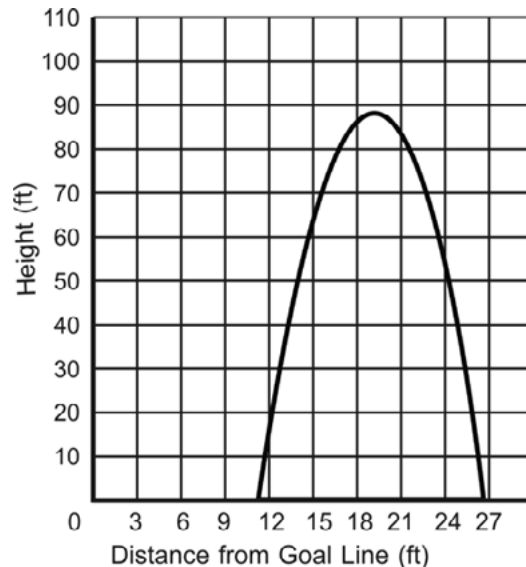

Team A

- Using the data from Team A, determine an equation that describes the path of the egg. Describe how you found your equation.
- On the graph below, graph the path of Team A’s egg.
- What is the maximum height that the egg reached? How far was the egg hurled?

Team B

- Using the equation from Team B, generate a table of values that shows different locations of the egg as it flew through the air.

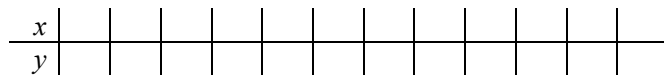

- On the graph below, graph the path of Team B’s egg.
- What is the maximum height that the egg reached? How far was the egg hurled?

Team C

- Using the data from Team C, generate a table of values that shows different locations of the egg as it flew through the air.

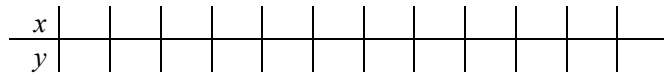

- On the graph below, re-graph the path of Team C’s egg.
- What is the maximum height that the egg reached? How far was the egg hurled?

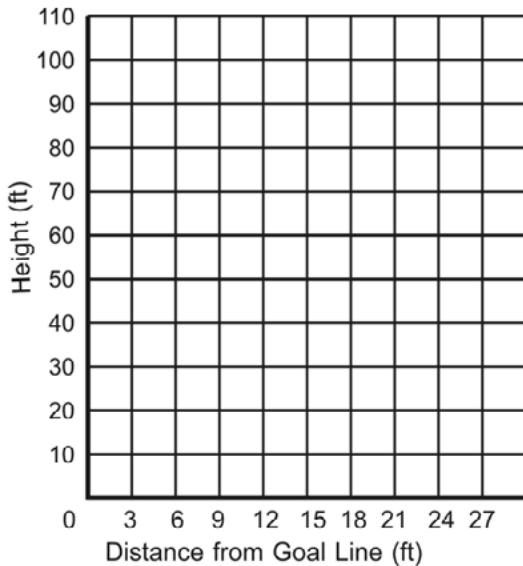

- If it is a height contest, which team wins? How do you know?
- If it is a distance contest, which team wins? How do you know?
- Find a method of determining a winner so that the team that did not win in Question 10 or Question 11 would win using your method.

Task #4: Tell an Egg-celent Story



Task #5: Making Sense of the Three Forms of Quadratic Functions

Often times the standard form of a quadratic is used in projectile motion. For this particular situation, the equation $h(t) = -\frac{1}{2}gt^2 + v_0t + h_0$ gives the height of an object at time t for an object that has initial velocity, v_0 and initial height of h_0 . “ g ” is a gravitational constant and is either $9.8m/s^2$ or $32ft/s^2$. Often times a simpler form of the equations look like:

For Meters - $h(t) = -9.8t^2 + v_0t + h_0$

For Feet - $h(t) = -16t^2 + v_0t + h_0$

1. A piece of paper and a hammer are dropped off the top of your school which is 90 feet high. They are both dropped from a still position (that is $v_0=0$ for both). If we ignore air resistance, which object, the paper or hammer, hits the ground first? Provide a mathematical argument that starts by sketching a picture of the graph and concludes with an analysis of the equation.

2. A potato is fired from a spud-gun at a height of 3m and an initial velocity of 25m/s, write the equation of this potato projectile. How high does the potato reach and at what time does this occur?

4. The Angry Birds Screen shot shows two flight paths of two different birds. Using a straight edge, construct a coordinate axes where the center of the slingshot is at the origin. Carefully assign point values to the two parabolas and write an equation for each. Show which points you used and which form of the equation you found most helpful.



Using mathematical analysis and your equations do the two birds hit at the same spot? Why or why not?

Task #6: Linear or Quadratic

Based on our work in this lesson and your work in the linear unit (Unit 3) explain in words the differences in LINEAR and QUADRATIC equations.

How is the structure of the equations different?

How is it similar? Are there similar techniques/processes, if so what?

Task #7: Skeleton Tower

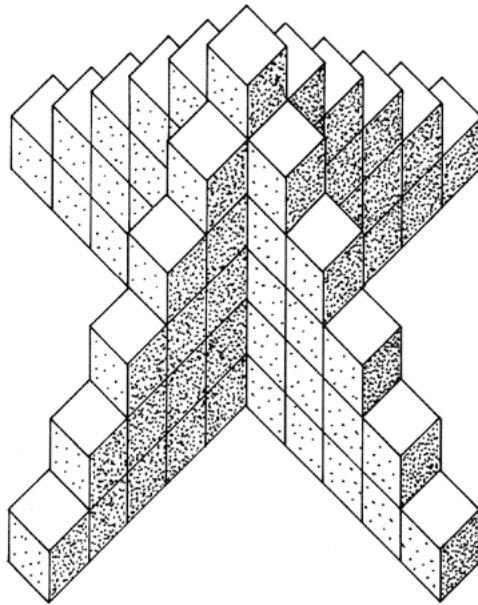

1. How many cubes are needed to build this tower?

Show your calculations

2. How many cubes are needed to build a tower like this, but 12 cubes high?

Explain how you figure out your answer.

3. How would you calculate the number of cubes needed for a tower n cubes high?

Task #8: Project Planning – Flight of the Gummy Bears

If our goal was to hit a target y -feet away, what would we need to know, what measurements would we need to record, what is our plan? How could we convince the class, using correct mathematical reasoning, that our projectile did indeed travel the furthest horizontally?

If our goal was to shoot the projectile the highest, what would we need to know, what measurements would we need to record, what is our plan? How could we convince the class, using correct mathematical reasoning that our projectile was indeed the highest?

Blank Targets

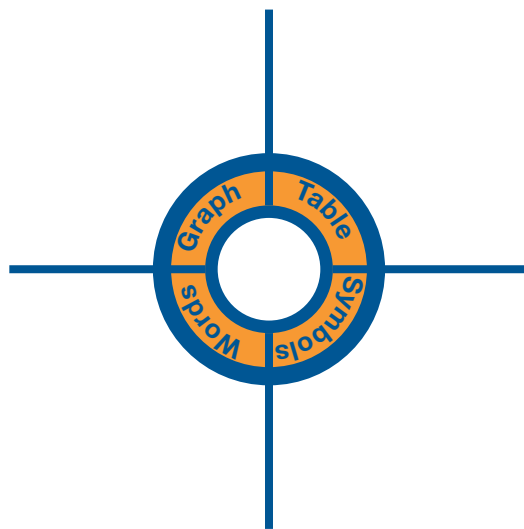
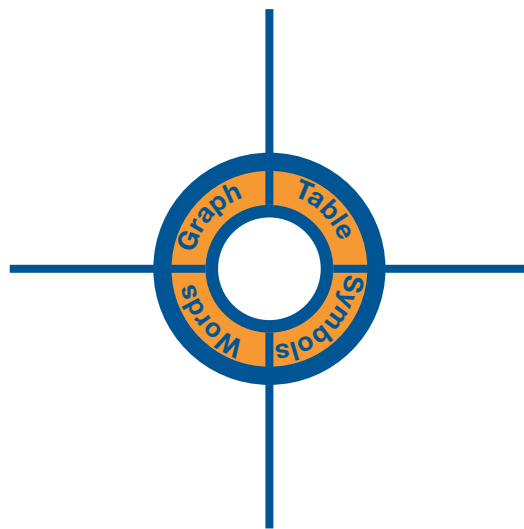
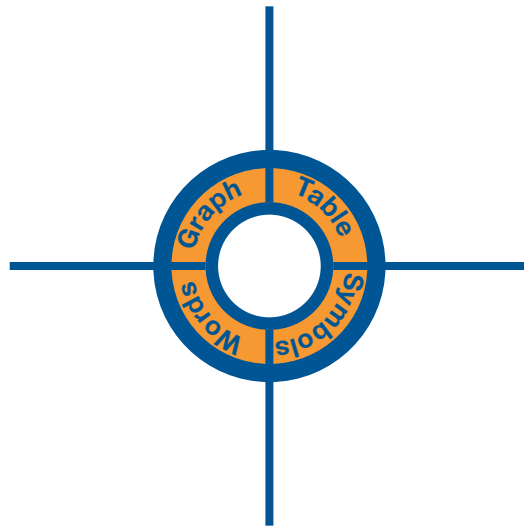

Task #9: The Same Yet Different

The purpose of this set of questions is to use the FORM to answer questions or to perhaps write the form to answer questions. You may only use a calculator for basic computational facts.

1. Suppose $h(t) = -5t^2 + 10t + 3$ is an expression giving the height of a diver above the water (in meters), t seconds after the diver leaves the springboard.

(a) How high above the water is the springboard? Explain how you know.

(b) When does the diver hit the water? Can you do this without a graphic calculator?

(c) At what time on the diver's descent toward the water is the diver again at the same height as the springboard?

(d) When does the diver reach the peak of the dive? *(You don't know how to do vertex form yet, but the idea that the vertex occurs half way between the x-intercepts should be encouraged as a method for solving.)*

2. A ball thrown vertically upward at a speed of v ft/sec rises a distance d feet in t , given by $d = 6 + vt - 16t^2$. Write an equation whose solution is:

(a) The time it takes a ball thrown at a speed of 88 ft/sec to rise 20 feet.

(b) The speed with which the ball must be thrown to rise 20 feet in 2 seconds.

3. A company's profit (in thousands of dollars) from an item depends on the price of the item. Three different expressions for the profit at a price of p dollars follow:

$$-2p^2 + 24p - 54$$

$$-2(p - 3)(p - 9)$$

$$-2(p - 6)^2 + 18$$

How could you convince someone that the three expressions are equivalent?

Which form is most useful for finding:

(a) The break-even prices? What are those prices, and how do you know?

(b) The profit when the price is 0? What is that profit, and what does it tell about the business situation?

(c) The price that will yield maximum profit? What is that price?

4. Coyote was chasing roadrunner, seeing no easy escape, Road Runner jumped off a cliff towering above the roaring river below. Molly mathematician was observing the chase and obtained a digital picture of this fall. Using her mathematical knowledge, Molly modeled the Road Runner’s fall with the following quadratic functions:

$$h(t) = -16t^2 + 32t + 48$$

$$h(t) = -16(t + 1)(t - 3)$$

$$h(t) = -16(t - 1)^2 + 64$$

a. Why does Molly have three equations?

b. Could you convince others that all three of these rules are mathematically equivalent?

c. Which of the rules would be most helpful in answering each of these questions? Explain.

i. What is the maximum height the Road Runner reaches and when will it occur?

ii. When would the Road Runner splash into the river?

iii. At what height was the Road Runner when he jumped off the cliff?

5. Complete the missing entries in the table. Each row represents the same quadratic function.

	Standard Form	Factored Form	Vertex Form	X-Intercepts	Y-Intercepts	Vertex
f(x)	$x^2 - 4x - 32$		$(x - 2)^2 - 36$			
g(x)		$(x - 3)(x + 6)$				
h(x)	$3x^2 - 10x - 8$					
k(x)			$(x - 2)^2 - 49$			
m(x)			$-(x+3)^2 + 25$			

Task #10: Flying Marshmallows

Launch your marshmallow out of a rolled up sheet of paper according to the directions below. Fill in all information as you go.

Outside Group Jobs:

Marshmallow Tech: _____

Timer: _____

Recorder: _____

Inside Group Jobs:

Equation Manager: _____

Graph Manager: _____

Accuracy Manager: _____

Quadratic One: Laying on your back

Have the person laying on their back launch the marshmallow. Make sure the timer keeps accurate time of how long the marshmallow is in the air. The recorder needs to record all data on this sheet.

Time Marshmallow was launched:

Height of marshmallow at launch:

Time Marshmallow landed:

Height of marshmallow at landing:

Sketch an accurate and labeled graph of the flight of your marshmallow

Show a table of the data you collected. Use the table to determine the maximum height of the marshmallow and the time at which this occurs.

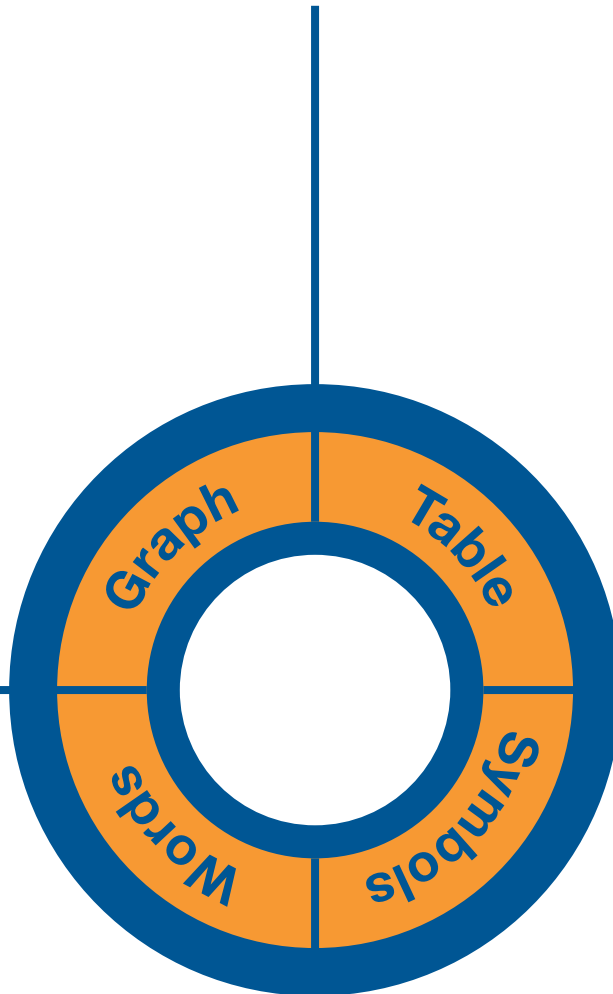

Write a description of what your marshmallow does.

Write the factored form of the flight of your marshmallow using:
 $h(t) = -16(x - t_1)(x - t_2)$

Write the equation for the flight of your marshmallow in factored form.

Write this in STANDARD FORM:

VERTEX FORM of a graph is $y = a(x - h)^2 + k$ where (h, k) is the vertex. Use this information and another point to write the VERTEX form of the function.

Task #12: Completing the Square

Method 1 – Algebra Tiles:

How does this algebra model tile representation illustrate the product of $(x + 4)^2$?

x^2	x	x	x	x
x	1	1	1	1
x	1	1	1	1
x	1	1	1	1
x	1	1	1	1

Let's look at an expanded form: $f(x) = x^2 + 8x + 10$

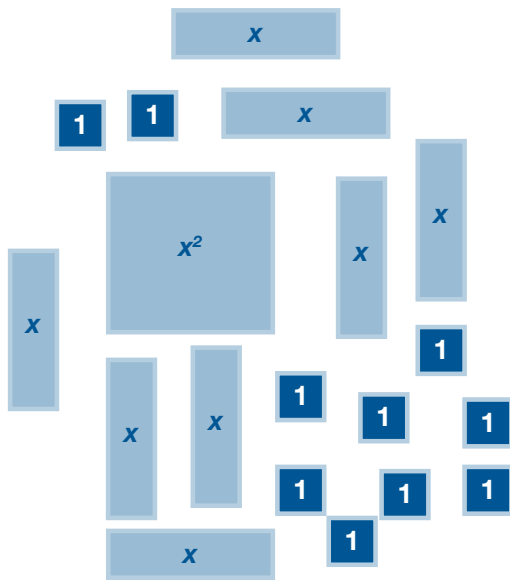

Try to arrange this set of tiles into a PERFECT SQUARE.

What problems are you running into?

What could be done to remedy this situation? If I were to allow you extra tiles, what would you need? Or would you rather take some away?

If you ignored for the time being all your “ones” how many ones would you need to make a PERFECT SQUARE?

How could we keep this net gain at zero?

The vertex form of this quadratic is $f(x) = (x + 4)^2 - 6$. Explain how this process helped me arrive at the vertex form.

Method 2 – Area Model (Algebra tiles generalized):

The squared expression $(x + 4)^2$ is represented geometrically to the right. Explain/make sense of this model.

	x	4
x	x^2	$4x$
4	$4x$	16

Let's try to reverse the process. Say I am building a PERFECT SQUARE and have the following. In each case, decide what it is I need to add on to have a completely perfect square. Draw an area model to illustrate your thought process.

a) $x^2 - 8x$

b) $x^2 - 10x$

c) $x^2 - 3x$

d) $x^2 + 14x$

e) $x^2 + 5x$

Now, what if I have $x^2 + 6x - 10$ and I would like to write it in vertex form. First I need a perfect square. Ignore the -10 and figure out what it is I need to complete my perfect square with $x^2 + 6x$.

How can you keep balance with what you have added to the problem?

Write $x^2 + 6x - 10$ in vertex form.

Task #13: Practice Vertex Form/Complete the Square

Write the following quadratics in vertex-form and give the vertex of the quadratic:

1) $f(x) = x^2 + 3x - 18$

2) $g(x) = x^2 + 2x - 120$

3) $h(x) = x^2 + 7x - 17$

4) $k(x) = x^2 + 9x + 20.25$

5) $s(x) = 4x^2 - 5x - 21$

6) $t(x) = 16x^2 + 9x + 20$

7) $f(x) = -2x^2 + 10x - 5$

8) $r(x) = -3x^2 - 5x + 2$

Practice for Lesson 6 Vertex Form/Completing the Square:

Worksheet 2: Practice for Lesson 6

1) What value is required to complete the square?

a) $x^2 + 20x +$ _____ b) $x^2 - 7x +$ _____ c) $x^2 - 4x +$ _____

2) Convert each quadratic function to vertex form AND find the coordinates of the max/min point on its graph.

a) $a(x) = x^2 + 12x + 11$

b) $b(x) = x^2 - 4x + 7$

c) $c(x) = x^2 - 18x + 74$

d) $d(x) = x^2 - 2x - 48$

e) $g(x) = x^2 - 2x - 8$

f) $f(x) = x^2 + 12x + 20$

3) For each of the functions you may use any method you choose to record the information in the table.

Function	x-intercepts	y-intercept	Max or min?	Vertex
$a^2 - 2a - 8 = 0$				
$b^2 + 2b - 33 = 0$				
$c^2 - 8c + 21 = 6$				
$d^2 + 13d + 22 = 7$				
$f^2 + 19f + 66 = 6$				

Task #14: Extension Piper and Golden Gate Bridge

Piper, the amazing golden retriever, likes to go exploring. Aiming to keep her home more, Stefanie has decided to fence in part of her yard. She purchased 500 feet of fencing at Lowes this weekend and plans to use the back side of her house as one side of the Piper-pen. Stefanie would like to fence in the largest possible area for Piper. Find the width and length that gives Piper the largest possible yard to play in.

Use vertex form to prove that of all rectangles with a given perimeter, a square has the greatest area.

The golden gate bridge spans 4,200 feet between towers. The towers supporting the cables are 500 feet high. Suppose the middle of the bridge is $(0,0)$. Write a function in vertex form to model the support cables on the Golden Gate Bridge. How high is the cable in the middle of the bridge?

Task #15: Conic Flyer

Describe in general terms how each parameter (slider) changes the graph:

(a) Purple

(b) Red

(c) Blue

1. Which of these parameters affects the range of each parabolic function? Explain.

2. The equation $y = 1(x - 0)^2 + 0$ or $y = x^2$ is considered the “parent” function for a vertical parabola. Find five points on the graph of $y = x^2$ and list them below.

3. Fold a sheet of graph paper into fourths, and draw a pair of y- and x- axes in each. Use your five values to graph $y = x^2$. in each fourth of the sheet. First predict how the graph of $y = x^2$ would change for each of the following and then sketch each on the graph paper (without substituting any points for the new equations below).

(a) $y = (x - 2)^2 + 4$

(b) $y = -(x + 3)^2 - 1$

(c) $y = 3(x + 1)^2 - 2$

(d) $y = -\frac{1}{3}(x + 1)^2 - 2$

4. Determine the range of each function above.

Task #16: Solving Quadratics

Using any method you choose, solve the following equations.

1. $3x + 7 = 5$

2. $3x^2 - 5 = 7$

3. $x^2 + 42x - 9 = 0$

4. $3x^2 + 15x - 6 = 0$

Task #17: Angry Birds

An angry bird's flight path is given by the equation $h(t) = 45 + 25t - 16t^2$. As a group, use this information and construct viable arguments for the following claims.

Are pigs at heights of 45, 57, and 65 hit or not?

If we can hit the pigs, determine how long it will take to hit each one?

Can all three pigs be hit on the same trajectory? Explain?

In the game of angry birds, you can't control the height of the slingshot or the effect of gravity, but you can change how far back and to what angle you pull on the slingshot to fire the bird. This manipulation would directly affect the initial velocity of the bird. In our original equation the velocity was 25. If you did not hit one of the pigs at 45, 57, or 65, manipulate the value of b (to signify changing the slingshot fire) to see if you could hit one of the pigs. Provide a justified conclusion of your findings.

Task #18: Two Squares

Solve the quadratic equation using as many different methods as possible.

$$x^2 = (2x - 9)^2$$

Task #19: Solving Quadratics with tables and graphs

Some highway patrol officers use the formula $d = 0.05s^2 + 1.1s$ to predict (or sometimes analyze) stopping distance, d , for speeds, s . For the following equations, find the solution and explain what each says about stopping distance.

a) $180 = 0.05s^2 + 1.1s$

b) $95 = 0.05s^2 + 1.1s$

c) $d = 0.05(45)^2 + 1.1(45)$

d) $d = 0.05(60)^2 + 1.1(60)$

The height of a football, in feet, kicked from the ground at time, t , in seconds, can be estimated by the equation $h(t) = 35t - 16t^2$.

a. Write and solve an equation to show when the football hits the ground at the end of its flight.

b. Regulation for high school, NCAA and the NFL require the goal post to be 10 feet above the ground. At what times is the ball 10 feet or higher above the ground? Show your work.

Task #20: Solving Quadratic Functions with tables and graphs

Show all work to make sure others can follow your approach.

1. $3(x - 4)^2 - 2 = 25$

2. $(6x + 5)(2x - 1) = 0$

3. $9x^2 + 4.7x - 6 = 0$

Task #21: Evaluating Others Thinking Quiz

Three students, Jerome, Chelsey, and Travis, were asked to solve the following quadratic equation:

$$x^2 + 4x - 11 = 10$$

They have shared their processes of solving this problem with you below:



Factoring is easy, bro'. Therefore, I started this equation by first moving the 10 to set the equation equal to zero. (Because before you factor it has to be equal to zero.)

Then I looked at factors of -21 that added to 4. I came up with -3 and 7. So my equation now looks like this:

$$(x-3)(x+7)=0$$

By the zero product property, I know in order for the product to be zero, one of the factors must be zero. Therefore $x-3 = 0$ is one answer which gives me $x=3$ AND $x+7=0$ is another answer which gives me $x=-7$. My final answers $x=-7$ and 3.

Graphing is MONEY! It's so easy—all you have to do is press a few buttons and it's done. But first you have to get the equation to one side, so I subtracted 10 from both sides to get:

$$x^2 + 4x - 21 = 0$$

Then I put this in Y1 of my calculator and pressed graph. I noticed that this parabola crosses the x-axis twice and the y-axis once. Then I went to my table and got confused. I saw zero three times in different places. When $x=3$, -7 and when $y=-21$. So I guess there are three answers: -21 , -7 , and 3. But I am not sure?



I really need to work on completing the square. I get some of the ideas but need practice so I tried this problem by completing the square. To start I got everything to one side. Then I regrouped my terms and left spaces for the "little square" (ones) I was going to add in. I figured out that I needed 4 to "complete my square", so I added 4 and subtracted 4 to keep balance. So now I have

$$(x^2 + 4x + 4) - 21 - 4 = 0$$

I simplified this to . Then I started to solve by adding 25 to both sides to get $(x + 2)^2 - 25 = 0$. Now take the square root of both sides to get $x+2=5$ and $x+2=-5$. Solving both of these gives me AND so my two answers are 3 and -7.

Evaluate Others Thinking Quiz

What do Jerome's, Travis's and Chelsey's methods have in common?

Are the three students correct in their reasoning?

Travis seems to be confused. Provide an explanation (can include words and pictures) to clear up Travis' confusion.

Will all three methods always work? Why or why not? Explain.

Using the method of your choice, solve the following quadratic. $x^2 - 4x - 90 = 0$
Indicate whose method you choose and WHY.

Task #22: Formative Assessment/Introductory Activities

1. Draw, if possible, a quadratic function that has:

a. zero roots

b. one root

c. two roots

d. three roots

2. Solve $2(x + 3)^2 - 5 = 0$ without a calculator.

3. Solve $2x^2 + 12x - 13 = 0$ without a calculator. (If you can't do this, don't worry. We will get to it in this lesson but give it a try.)

Task #23: Completing the Square to Quadratic Formula

The main body of the lesson:

Consider again $2x^2 + 12x - 13 = 0$. We will review how, using the clever completing the square trick, we can change the form of this equation to make it easier to solve.

- (a) Complete the missing step below:

$$\text{Note that } 2x^2 + 12x - 13 = 2(x^2 + \underline{\hspace{2cm}}) - 13$$

- (b) Which of the following choices is equal to $2(x^2 + 6x) - 13$

(i) $2(x^2 + 6x + 9) - 13$ (ii) $2(x^2 + 6x + 9) - 4$

(iii) $2(x^2 + 6x + 9) - 22$ (iv) $2(x^2 + 6x + 9) - 5$

- (c) Since $x^2 + 6x + 9 = (x + 3)^2$, use your answers to (a) and (b) above to complete the following sentence:

$$2x^2 + 12x - 13 = \underline{\hspace{2cm}} (x + 3)^2 - \underline{\hspace{2cm}}$$

- (d) Use your answer to (c) to solve $2x^2 + 12x - 13 = 0$ (Hint: you already did this)

We will now do something similar to develop the important and powerful Quadratic Formula, a formula that allows us to solve EVERY quadratic equation.

Suppose we need to solve the equation $ax^2 + bx + c = 0$ for x .

- (a) Complete the missing step below:

$$\text{Note that } ax^2 + bx + c = a(x^2 + \underline{\hspace{2cm}}) + c$$

- (b) Complete the missing step below:

$$a(x^2 + \frac{b}{a}x) + c = a(x^2 + \frac{b}{a}x + \frac{b^2}{4a^2}) + \underline{\hspace{2cm}}$$

- (c) Factor $x^2 + \frac{b}{a}x + \frac{b^2}{4a^2}$

- (d) Use your answers to (a), (b) and (c) above to complete the following sentence:

$$ax^2 + bx + c = a(x + \underline{\hspace{2cm}})^2 - \underline{\hspace{2cm}}$$

- (e) Use your answer to (d) to solve the equation $ax^2 + bx + c = 0$
(Hint: think about what you did to solve $2(x + 3)^2 - 5 = 0$).

Explain why the part of the formula $b^2 - 4ac$ (called the discriminant) tells you—without graphing—how many real roots the quadratic equation will have.

The Quadratic Formula

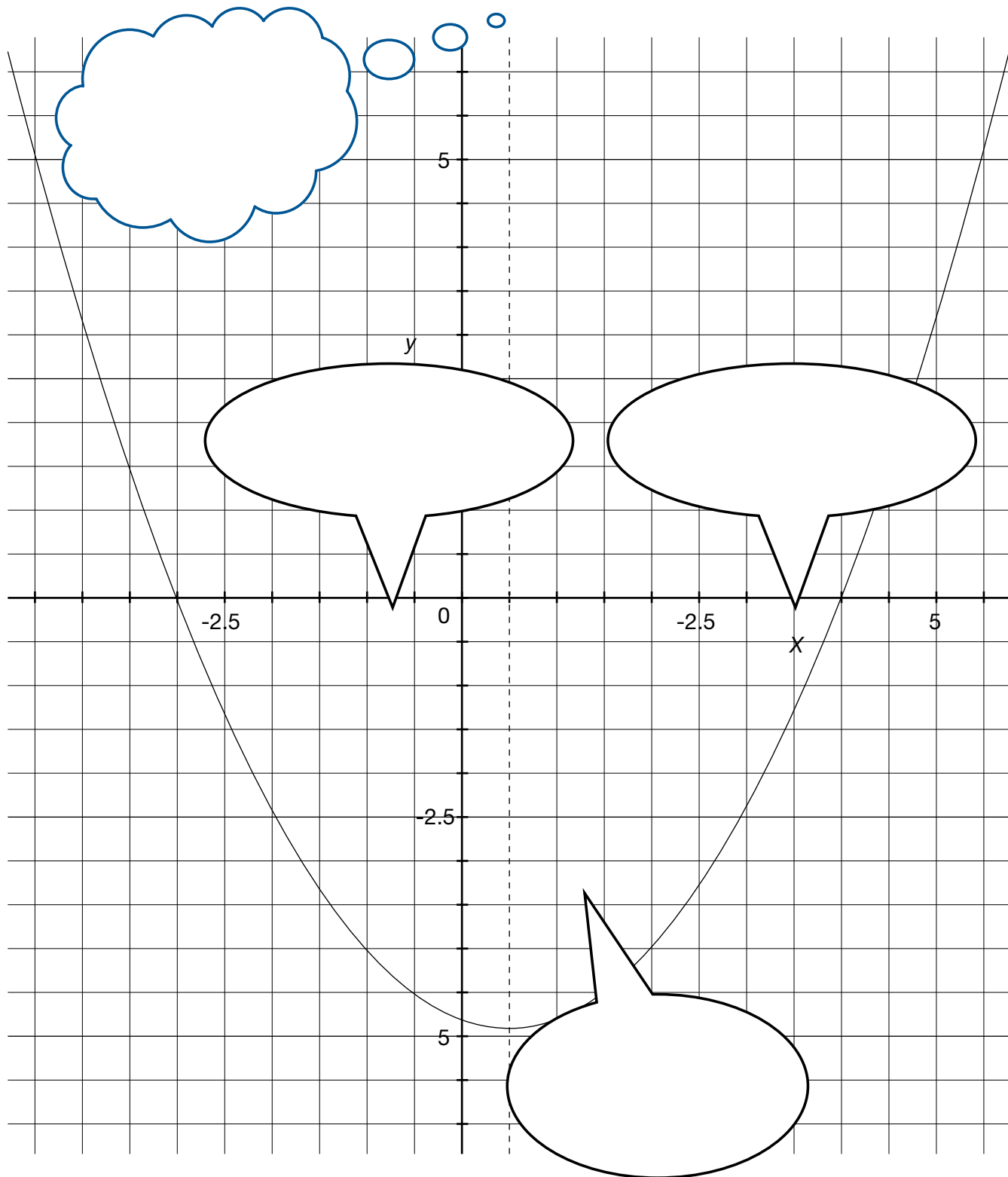

Task #24: Rockets

Rockets were assembled from kits by members of an engineering club and were launched from the ground at the same time. The height y in feet of one rocket after t seconds is given by $y = -16t^2 + 150t + 5$. The height of the other rocket is given by $y = -16t^2 + 160t$. After how many seconds are the rockets at the same height? What is this height?

Task #25: Practice Problems Non-Linear Systems

For each system below:

- a) Graph each system by hand. If an equation is linear, rewrite it in slope-intercept form first and use this to help graph the line. If an equation is quadratic, rewrite it in vertex form and use this to help graph the parabola. Show your work next to each graph.
- b) Verify your results with a graphing utility.

$$1) \begin{cases} y = x^2 + 1 \\ y = 4x + 1 \end{cases}$$

$$2) \begin{cases} y - x = -1 \\ y = x^2 - 6x + 9 \end{cases}$$

$$3) \begin{cases} 3x - y = -2 \\ 2x^2 - y = 0 \end{cases}$$

$$4) \begin{cases} y = -1 \\ y = -2x^2 + 4x - 5 \end{cases}$$

Task #26: Gummy Bear Shoot Off

Using a tongue depressor, rubber band and a gummy bear you will devise a contraption to “fire” your gummy bear. The object of this project is not in the design of your firing device but rather your mathematical analysis of the flight of your gummy bear. This competition is similar to the egg launch we looked at in Lesson 3. In fact, you may wish to reference the brainstorming ideas from that lesson.

You are to fire your gummy bear and collect all necessary data. As a group, you will prepare one report that must include careful mathematical analysis of your gummy bear including equations, graphs, tables and descriptions. Write AND answer questions about the flight of your gummy bear.

Your final project will be graded according to the rubric and evaluated for mathematical correctness and completion.

In your report include reflections on the following questions:

- Synthesize what you have learned in this unit. How did you incorporate those ideas into your mathematical analysis of your gummy bear?
- How do the different forms of a quadratic reveal different information about the flight of your gummy bear? In answering questions?

Topic	Not Yet	Getting There	Proficient	Highly Proficient
Tables and Graphs	Tables and graphs are missing or incomplete	Tables and graphs are present but contain mechanical flaws	Tables and graphs are present and correct	Tables and graphs are present and correct and are discussed and/or connected in other areas of the analysis.
Equations	Equations are incorrectly calculated	Equations show signs of correct thinking but flaws are present (in procedure or understanding)	Equations are correct and all work is shown how they were developed.	Equations are thorough and correct and connected to other areas of the analysis.
Analysis of Mathematics	Mathematical analysis contains flaws in conceptual understanding. Tables, graphs and equations are presented as three separate pieces and not tied together.	Mathematical analysis has gaps in understanding. Demonstrates a basic understanding but does not comprehend the interplay of tables, graphs, and equations.	Demonstrates understanding of the interplay of tables, graphs, and equations and can accurately describe the scenario in terms of all.	Exceeds proficient and demonstrates a solid foundation in analyzing a mathematical situation from all standpoints.
Questions in Regard to Flight	Ask two or fewer questions that are relevant and make sense to the data collected	Ask three questions but may not be relevant or make sense to the data	Ask three “good” questions that make sense to ask and are relevant to data	Ask in-depth questions that demonstrate a complex understanding of the concepts. Questions are well thought out and relevant.
Answers to Questions Asked	Did not answer questions correctly	Answered questions but incorrect thinking or contains mathematical flaws OR did not provide justification of answers (bald answers)	Answered questions correctly and provides justification	Answers are well documented and supported and display an in-depth understanding of the concept
Synthesis of Unit as a Whole	Project does not show overall mathematical understanding. Significant gaps in mathematics.	Project shows some understanding of math but disjointed. Information is spotty and incomplete	Project displays a cohesive, comprehensive understanding of quadratic functions. Ideas are connected and there are no mathematical flaws.	Project goes above and beyond and shows an in-depth complex understanding of analyzing quadratic functions.
Overall Cohesiveness of Project	Project is disjointed and put together in pieces	Some areas of project are disjointed – lacks clarity and/or focus	Project feels as “one” project. Pieces fit together and flow	Project is cohesive and complex and answers all questions in a non-list rather, comprehensive, manner

SREB

SREB Readiness Courses
Transitioning to college and careers

College Readiness Mathematics

Unit 7 . Exponential Functions
Version 3

Southern
Regional
Education
Board

592 Tenth Street, NW
Atlanta, GA 30318
(404) 875-9211

www.sreb.org

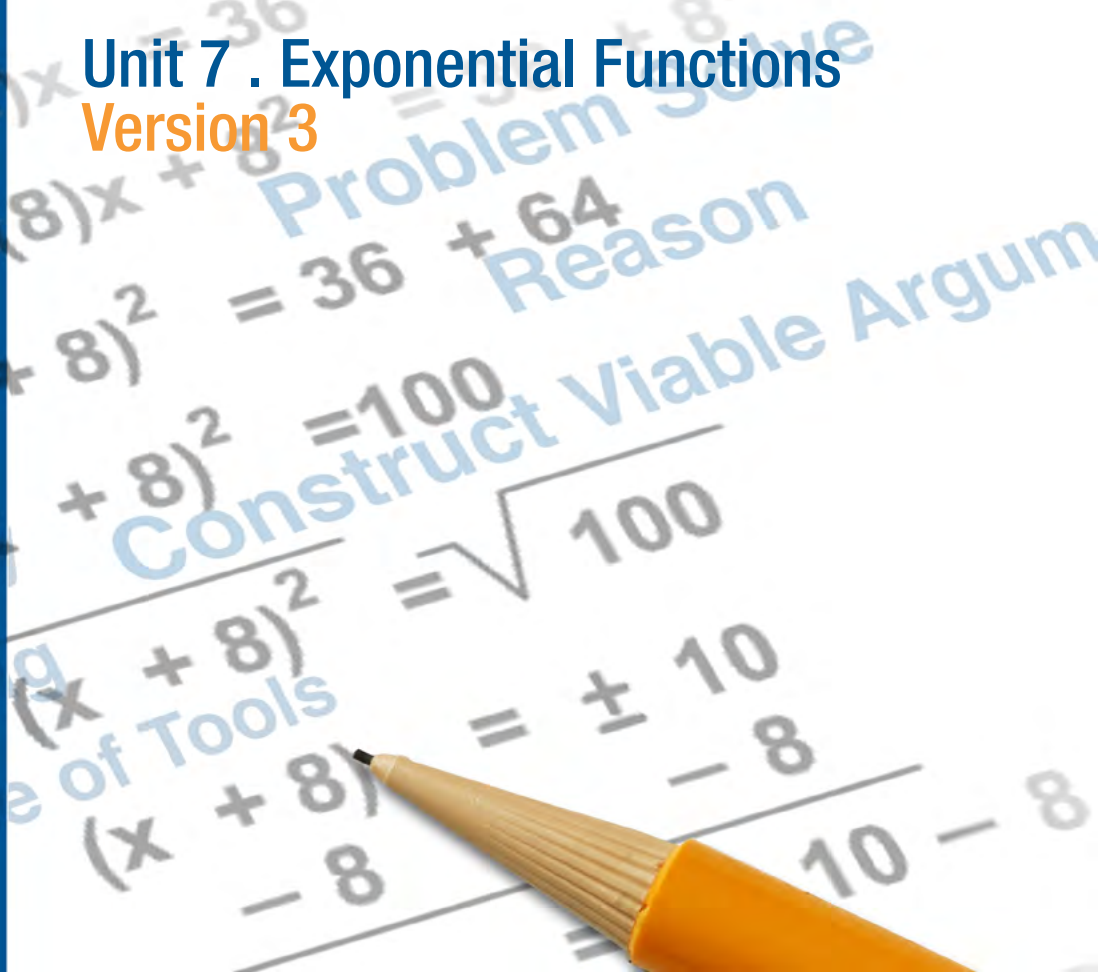

Unit 7 . Exponential Functions

Overview

Purpose

In this unit, students will experience exponential functions through a real-world lens of finance. Beginning with an overall look into financial decisions they will face as adults, students study the mathematics involved in purchasing a car, planning for retirement and even deciding on a job.

Essential Questions:

Why might two expressions look different but be mathematically the same?

Why might someone want to change the way an expression is written?

How would you know that two expressions are mathematically equivalent?

When might real life financial situations be modeled with math?

Why would some debts be considered good or bad?

Why will it matter how interest is compounded on borrowed money?

When would financial situations follow an exponential growth or decay and how would you determine if it is exponential growth or decay?

How would you apply the concept of sequences to different types of debt?

Georgia Standards of Excellence

Seeing Structure in Expressions

Interpret the structure of expressions.

- MGSE9-12.A.SSE.1: Interpret expressions that represent a quantity in terms of its context.
- MGSE9-12.A.SSE.1a: Interpret parts of an expression, such as terms, factors and coefficients, in context.
- MGSE9-12.A.SSE.1b: Given situations which utilize formulas or expressions with multiple terms and/or factors, interpret the meaning (in context) of individual terms or factors.
- MGSE9-12.A.SSE.2: Use the structure of an expression to rewrite it in different equivalent forms. For example, see $x^4 - y^4$ as $(x^2)^2 - (y^2)^2$, thus recognizing it as a difference of squares that can be factored as $(x^2 - y^2)(x^2 + y^2)$.

Write expressions in equivalent forms to solve problems.

- AMGSE9-12.A.SSE.3: Choose and produce an equivalent form of an expression to reveal and explain properties of the quantity represented by the expression.
- MGSE9-12.A.SSE.3a: Factor any quadratic expression to reveal the zeros of the function defined by the expression.
- MGSE9-12.A.SSE.3b: Complete the square in a quadratic expression to reveal the maximum or minimum value of the function defined by the expression.

Creating Equations

Create equations that describe numbers or relationships.

- MGSE9-12.A.CED.2: Create linear, quadratic, and exponential equations in two or more variables to represent relationships between quantities; graph equations on coordinate axes with labels and scales. (The phrase “in two or more variables” refers to formulas like the compound interest formula, in which $A = P(1 + r/n)^{nt}$ has multiple variables.)
- MGSE9-12.A.CED.4: Rearrange formulas to highlight a quantity of interest using the same reasoning as in solving equations. Examples: Rearrange Ohm’s law $V = IR$ to highlight resistance R ; Rearrange area of a circle formula $A = \pi r^2$ to highlight the radius.

Interpreting Functions

Interpret functions that arise in applications in terms of the context.

- MGSE9-12.F.IF.4: Using tables, graphs, and verbal descriptions, interpret the key characteristics of a function which models the relationship between two quantities. Sketch a graph showing key features including: intercepts; interval where the function is increasing, decreasing, positive, or negative; relative maximums and minimums; symmetries; end behavior; and periodicity.

Analyze functions using different representations.

- MGSE9-12.F.IF.7: Graph functions expressed algebraically and show key features of the graph both by hand and by using technology.

- MGSE9-12.F.IF.7e: Graph exponential and logarithmic functions, showing intercepts and end behavior, and trigonometric functions, showing period, midline and amplitude.
- MGSE9-12.F.IF.8: Write a function defined by an expression in different but equivalent forms to reveal and explain different properties of the function.
- MGSE9-12.F.IF.8b: Use the properties of exponents to interpret expressions for exponential functions. For example, identify percent rate of change in functions such as $y = (1.02)^t$, $y = (0.97)^t$, $y = (1.01)^{(12t)}$, $y = (1.2)^{(t/10)}$ and classify them as representing exponential growth and decay.

Building Functions

Build a function that models a relationship between two quantities.

- MGSE9-12.F.BF.1: Write a function that describes a relationship between two quantities.
- MGSE9-12.F.BF.1a: Determine an explicit expression and recursive process (steps for calculation) from context. For example, if Jimmy starts out with \$15 and earns \$2 a day, the explicit expression “ $2x + 15$ ” can be described recursively (either in writing or verbally) as “to find out how much money Jimmy will have tomorrow, you add \$2 to his total today.” $J_n = J_{n-1} + 2$, $J_0 = 15$.
- MGSE9-12.F.BF.2: Write arithmetic and geometric sequences recursively and explicitly, use them to model situations, and translate between the two forms. Connect arithmetic sequences to linear functions and geometric sequences to exponential functions.

Linear, Quadratic, and Exponential Models

Construct and compare linear, quadratic, and exponential models and solve problems.

- MGSE9-12.F.LE.1: Distinguish between situations that can be modeled with linear functions and with exponential functions.
- MGSE9-12.F.LE.1a: Show that linear functions grow by equal differences over equal intervals and that exponential functions grow by equal factors over equal intervals. (This can be shown by algebraic proof, with a table showing differences or by calculating average rates of change over equal intervals.)
- MGSE9-12.F.LE.1b: Recognize situations in which one quantity changes at a constant rate per unit interval relative to another.
- MGSE9-12.F.LE.1c: Recognize situations in which a quantity grows or decays by a constant percent rate per unit interval relative to another.
- MGSE9-12.F.LE.2: Construct linear and exponential functions, including arithmetic and geometric sequences, given a graph, a description of a relationship, or two input-output pairs (include reading these from a table).
- MGSE9-12.F.LE.3: Observe using graphs and tables that a quantity increasing exponentially eventually exceeds a quantity increasing linearly, quadratically, or (more generally) as a polynomial function.

Interpret expressions for functions in terms of the situation they model.

- MGSE9-12.F.LE.5: Interpret the parameters in a linear ($f(x) = mx + b$) and exponential ($f(x) = a \cdot d^x$) function in terms of context. (In the functions above, “m” and “b” are

the parameters of the linear function, and “a” and “d” are the parameters of the exponential function.) In context, students should describe what these parameters mean in terms of change and starting value.

Prior Scaffolding Knowledge / Skills:

Students should be comfortable working with expressions and equations that have numerical and variable exponents.

Students should understand the relationship between radicals and rational exponents.

Students should have a solid understanding of a function being defined as a rule that assigns to each input exactly one output.

Lesson Progression Overview:

Lesson Big Idea	Lesson Details	Georgia Standards of Excellence	Standards for Mathematical Practice
Lesson 1: Exponential Growth and Decay	The hook to this unit introduces students to some of the financial decisions they will face as adults. As they investigate different job opportunities, they are asked to compare and contrast linear and exponential functions as well as exponential growth and decay functions.	MGSE9-12.A.SSE.3 MGSE9-12.A.CED.2 MGSE9-12.F.IF.4 MGSE9-12.F.IF.7 MGSE9-12.F.IF.7e MGSE9-12.F.IF.8 MGSE9-12.F.IF.8b MGSE9-12.F.BF.1 MGSE9-12.F.BF.1a MGSE9-12.F.LE.1 MGSE9-12.F.LE.1a MGSE9-12.F.LE.1b MGSE9-12.F.LE.1c MGSE9-12.F.LE.2 MGSE9-12.F.LE.3 MGSE9-12.F.LE.5	SMP 4 SMP 6 SMP 8
Lesson 2: Structure in Exponential Functions	In this lesson, students examine the patterns in exponential functions and refine their understanding of the components of an exponential function. Attention is given to the structure of an exponential equation and how the structure of equivalent expressions can reveal different key pieces of information. Students will use real life data to model exponential growth situations.	MGSE9-12.A.SSE.3 MGSE9-12.A.CED.2 MGSE9-12.F.IF.4 MGSE9-12.F.IF.7 MGSE9-12.F.IF.7e MGSE9-12.F.IF.8 MGSE9-12.F.IF.8b MGSE9-12.F.BF.1 MGSE9-12.F.BF.1a MGSE9-12.F.LE.1 MGSE9-12.F.LE.1a MGSE9-12.F.LE.1b MGSE9-12.F.LE.1c MGSE9-12.F.LE.2 MGSE9-12.F.LE.5	SMP 4 SMP 7 SMP 8

Lesson Big Idea	Lesson Details	Georgia Standards of Excellence	Standards for Mathematical Practice
Lesson 3: Compounding Interest	In lesson three, students extend their study of exponential functions into applications of calculating interest. Along with an examination of different ways interest is compounded, students also experience the long-term effects of what can appear to be a small difference in interest.	MGSE9-12.A.SSE.3 MGSE9-12.A.CED.4 MGSE9-12.F.LE.1 MGSE9-12.F.LE.1a MGSE9-12.F.LE.1b MGSE9-12.F.LE.1c MGSE9-12.F.LE.2 MGSE9-12.F.LE.5	SMP 2 SMP 3 SMP 4 SMP 5
Lesson 4: Formative Assessment Lesson: Comparing Investments	<p>This lesson is intended to help you assess how well students are able to interpret exponential and linear functions. Students will translate between descriptive, algebraic and tabular data, and graphical representation of the functions and will also be asked to recognize how, and why, a quantity changes per unit interval.</p> <p>To achieve these goals students work on simple and compound interest problems.</p>	MGSE9-12.A.SSE.1 MGSE9-12.A.SSE.1a MGSE9-12.A.SSE.1b MGSE9-12.A.SSE.2 MGSE9-12.A.SSE.3 MGSE9-12.F.LE.1 MGSE9-12.F.LE.1a MGSE9-12.F.LE.1b MGSE9-12.F.LE.1c	SMP 1 SMP 2 SMP 4 SMP 7
Lesson 5: Monthly Savings	Students extend the structure of exponential growth as it relates to compound interest and begin to look at monthly additions to an account to reach savings goals (as opposed to a static interest earning situation of a one time pay-in account). The real world application of retirement savings is addressed.	MGSE9-12.A.SSE.3 MGSE9-12.A.CED.4 MGSE9-12.F.IF.8 MGSE9-12.F.IF.8b MGSE9-12.F.BF.1 MGSE9-12.F.BF.1a MGSE9-12.F.BF.2 MGSE9-12.F.LE.2 MGSE9-12.F.LE.5	SMP 1 SMP 5 SMP 8
Lesson 6: Comparing Payment Options	In this final lesson, students will look at different payment options for purchasing a car. They will be looking at the amount of interest charged monthly and how that interest accumulates over the course of the loan.	MGSE9-12.A.SSE.3 MGSE9-12.A.CED.4 MGSE9-12.F.IF.8 MGSE9-12.F.IF.8b MGSE9-12.F.BF.1 MGSE9-12.F.BF.1a MGSE9-12.F.BF.2 MGSE9-12.F.LE.2 MGSE9-12.F.LE.5	SMP 4 SMP 8

Exponential Functions

Lesson 1 of 6

Exponential Growth and Decay

Description:

The hook to this unit introduces students to some of the financial decisions they will face as adults. As they investigate different job opportunities, they are asked to compare and contrast linear and exponential functions as well as exponential growth and decay functions.

Georgia Standards of Excellence Addressed:

- MGSE9-12.A.SSE.3: Choose and produce an equivalent form of an expression to reveal and explain properties of the quantity represented by the expression.
- MGSE9-12.A.CED.2: Create linear, quadratic, and exponential equations in two or more variables to represent relationships between quantities; graph equations on coordinate axes with labels and scales. (The phrase “in two or more variables” refers to formulas like the compound interest formula, in which $A = P(1 + r/n)^{nt}$ has multiple variables.)
- MGSE9-12.F.IF.4: Using tables, graphs, and verbal descriptions, interpret the key characteristics of a function which models the relationship between two quantities. Sketch a graph showing key features including: intercepts; interval where the function is increasing, decreasing, positive, or negative; relative maximums and minimums; symmetries; end behavior; and periodicity.
- MGSE9-12.F.IF.7e: Graph exponential and logarithmic functions, showing intercepts and end behavior, and trigonometric functions, showing period, midline and amplitude.
- MGSE9-12.F.BF.1: Write a function that describes a relationship between two quantities.
- MGSE9-12.F.BF.1a: Determine an explicit expression and recursive process (steps for calculation) from context. For example, if Jimmy starts out with \$15 and earns \$2 a day, the explicit expression “ $2x + 15$ ” can be described recursively (either in writing or verbally) as “to find out how much money Jimmy will have tomorrow, you add \$2 to his total today.” $J_n = J_{n-1} + 2, J_0 = 15$
- MGSE9-12.F.LE.1: Distinguish between situations that can be modeled with linear functions and with exponential functions.
- MGSE9-12.F.LE.1a: Show that linear functions grow by equal differences over equal intervals and that exponential functions grow by equal factors over equal intervals. (This can be shown by algebraic proof, with a table showing differences or by calculating average rates of change over equal intervals.)
- MGSE9-12.F.LE.1b: Recognize situations in which one quantity changes at a constant rate per unit interval relative to another.

- MGSE9-12.F.LE.1c: Recognize situations in which a quantity grows or decays by a constant percent rate per unit interval relative to another.
- MGSE9-12.F.LE.2: Construct linear and exponential functions, including arithmetic and geometric sequences, given a graph, a description of a relationship, or two input-output pairs (include reading these from a table).
- MGSE9-12.F.LE.3: Observe using graphs and tables that a quantity increasing exponentially eventually exceeds a quantity increasing linearly, quadratically, or (more generally) as a polynomial function.
- MGSE9-12.F.LE.5: Interpret the parameters in a linear ($f(x) = mx + b$) and exponential ($f(x) = a \cdot d^x$) function in terms of context. (In the functions above, “m” and “b” are the parameters of the linear function, and “a” and “d” are the parameters of the exponential function.) In context, students should describe what these parameters mean in terms of change and starting value.

Standard(s) for Mathematical Practice Emphasized:

- SMP 4: Model with mathematics.
- SMP 6: Attend to precision.
- SMP 8: Look for and express regularity in repeated reasoning.

Sequence of Instruction

Activities Checklist

Engage

Entry Event: This unit hook will give students a chance to look into their future and gain some understanding of financial decisions they will soon need to make as adults. Exponential functions appear often in daily financial planning, although many people fail to understand the mathematics behind some of the many important financial decisions that are made. This conversation with students will introduce them to some of the many topics they will encounter in this unit and in their adult lives.

- Prior to the class, the teacher should research and be ready to provide students with the following (either on paper or electronically):
 - A diverse list (with pictures and prices) of 8-12 local homes on the market.
 - A diverse list (with pictures and prices) of 8-12 vehicles.
 - Varying amounts of consumer debt printed on slips of paper that the student will blindly choose— \$0-\$35,000 (average is \$15,969 <http://www.creditcards.com/c3credit-card-news/credit-card-industry-facts-personal-debt-statistics-1276.php>).
 - Monthly expenses by family type (for food, clothing, etc.) and be prepared to provide the students with average ranges of those values.
 - Varying amounts of student loans printed on slips of paper that the student will blindly choose (if post-secondary education is chosen).
- Students should decide on an education level they plan to complete and consider their future plans for a family (spouse/partner or not, children or not, and if so, how many). Based on those decisions, allow them a few minutes to research their estimated yearly income for a career of their choice.

- Students should then, based on their income and family decisions, select a home, vehicle, and monthly expenses by family type. They will blindly choose consumer debt and student loans.
- Conclude this activity with a whole-group discussion of their financial planning. The following questions:
 - What decisions did you take into consideration based on your income?
 - What other expenses did you consider to be life’s necessities?
 - Did you consider any expenses associated with maintenance for your home or vehicle?
- Discuss with students how an understanding of the mathematics behind these financial decisions can equip them later in life to make better financial choices. In this unit, they will delve farther into the study of exponential functions that was started in Unit 4 with the iTunes app download problem.

Explore



Explain the following scenario: You are offered a job with a starting annual salary of \$50,000 and two options for determining your annual raise:

- An annual raise of \$3,000 per year.
- A 5% raise each year.

Which job offer is better?

Ask for two (or more) volunteers to come to the board. Give each volunteer three (of the same) colors of markers. Have one student set up a table with three columns such as the one below —

t	f(t)	g(t)
0		
1		
2		

where $y=f(t)$ and $y=g(t)$ denote your salaries t years after being hired with the fixed annual raise and fixed percent raise, respectively.

The other student should set up a graph with axes, ticks and gridlines drawn in the same color as the one used for t in the table above. It is important to the process of learning mathematics that the students arrive at their own scale for setting up this problem rather than being directed.

Ask the class what this person’s annual salary would be one year later, when $t=1$? Begin filling in the table and plot the corresponding point on the graph, using the same color for $f(t)$ in each as well as matching colors for $g(t)$. Lead students to observe that for $f(1)$ the raise will be \$3,000 and for $g(1)$ the raise is \$2,500. So, the \$3,000 per year option is better? Certainly if you plan to work only one year.

Ask students, “What would this person’s salary be in two years after being hired according to each offer? What was the raise in each case?” Students may be unclear as to whether the raise under option two is always 5% of \$50,000 every year (thus incorrectly thinking it is a \$2,500 annual raise) or whether you are taking 5% of the current year’s salary, \$52,500. Lead students to see that $f(t)$ is growing by a constant amount while $g(t)$ did not grow by the same absolute amount. The raise from year one

to year two is more (\$2,625). Ask, “Do you think $f(t)$ will be linear? Will $g(t)$ be linear?” Remember, $g(t)$ is growing by a fixed percent while $f(t)$ is growing by a fixed absolute amount.

Now, split students up into smaller groups of three to four students per group as they explore this topic further on their own.

Give each group a large chart pad of paper and ask them to set up a table and graph identical to the one on the board.

Ask students to fill out the table (and simultaneously plot points on the graph) corresponding to this person’s salary for years $t=1$ up to $t=10$.

Based on their findings, which job offer is better? What if they plan on working at this job for 20 years, what would be the salary under each option? The intent here is not for students to complete 20 rows of the table, but rather, to look for repeating reasoning.

Explanation



Go around the room and ask groups to share which salary option they thought was best. Hopefully you hear a lot of “it depends on how long they plan to work at that job.” Students should discover that $f(t)$ is a higher salary the first eight years, but beginning on year nine, $g(t)$ is a better annual salary.

Ask one of the groups to explain how they completed the values in their table. Move students toward finding a general formula for each by finding patterns. Likewise, students are creating an equation to model a situation. For $f(t)$, students should recognize this is a linear function both from the graph and table. Make sure students are asked, “How can you recognize the function is linear from the table? From the graph? From the initial explanation?” Make sure students can explain the meaning of both the slope and y-intercept in the context of the problem. Have students (if not done so already) draw the line through the points and label it $y=f(t)$. Thus, we can actually find an equation $f(t) = 3,000t+50,000$. Ask students to explain how they would calculate their salary after 20 years.

Perhaps have a second group similarly explain how they found $g(3)$ (as class you found $g(1)$ and $g(2)$). Students are likely to say they took $f(2) = \$52,500$:

- Multiplied by 0.05 (to calculate the 5% raise).
- Then added this raise to \$52,500.
- Thus, $g(3) = (0.05)(52,500)+52,500$.

If the group does not mention they could rewrite this as $g(3)=(0.05)(52,500)+52,500=52,500(1+0.05)=52,500(1.05)$, find a group that did and ask them to share this observation, reviewing the difference in the structure of the numeric expressions $=(0.05)(52,500)+52,500$ and $52,500(1.05)$. If students don’t make the following observation themselves, point out multiplying by 1.05 is the equivalent of calculating the raise and adding it to the previous year’s salary.

At this time, discuss with students the differences between $f(t)$ and $g(t)$. Make sure students hear and are using appropriate vocabulary, e.g., **factor**, **growth factor**, **constant factor**. And, when discussing slope, call attention to the fact that in $g(t)$ values are not increasing at a constant rate, but rather, they are getting **steeper and steeper**.

Sketch the curve through the points and label the curve $y=g(t)$. If you noticed one of the groups found a general formula for the exponential function $y=g(t)$, ask them to explain how they found the general equation. If no group found a general formula, walk students

through the derivation of the general formula together, $g(t) = 50,000(1.05)^t$. A connection should also be made between the derivation of the general formula and the table.

Finally, mark the point where the two graphs intersect. Students see that the intersection point matches their findings from the table, namely in year nine, the fixed percent raise salary finally catches up and becomes more than the linear salary. Bring the intersection of the graphs back to the main question as far as which salary option is better, illustrating the significance of when $f(t) > g(t)$ (graph of f on top), $f(t)=g(t)$ (intersection), and $f(t) < g(t)$ (now graph g on top).

Finally, carefully write the general form for an exponential equation, using the correct definitions to refer to the parameters in the general formula. A function $Q=f(t)$ is called an **exponential function** if it can be written in the form:

$Q=Q_0a^t$ for some $a > 0$ (see note below regarding $a > 0$).

The coefficient Q_0 corresponds to the **initial value** of the quantity Q at time $t=0$. Graphically, it is the **vertical intercept** of the graph.

The base of the exponent, a , is called the **growth factor**. It tells us what factor we multiply by when we increase t by 1. From the growth factor, we can determine the **growth rate, r** , as follows. Since $a = 1+r$, we have $r = a-1$. The growth rate (not the growth factor) tells us by what **fixed percent** the quantity grows each time you increase t by one.

Draw the general shape of a graph of exponential growth (we'll deal with decay shortly). Point out the key features:

- The **vertical intercept** corresponds to Q_0 .
- The graph is **increasing** (at least for now in case of growth).
- The function is **increasing at an increasing rate** (not a constant rate). Mention that each year the raise for g was getting larger and larger. The **curve bends up**.
- As t becomes negative, the graph gets closer and closer to the t -axis, but it never touches the axis. We call this behavior a **horizontal asymptote at $Q=0$** . You may need to review what it means to raise a value to a negative power for students to see why the graph exhibits this behavior.
- The **domain is all real numbers**, unless we have a restriction based on the context (as with the salary example $t \geq 0$).
- The **range is $Q > 0$** .

Now point students back to the original description of the salary for g . You are hired with an initial salary of \$50,000 and offered a 5% raise each year. Based on this language explain how you could directly determine that this is an exponential function (growing by a fixed percent each year), and moreover, identify $r=0.05$ and $Q_0=50,000$.

The time the explanation requires will vary depending on the students. You may have time to set the students to practice more problems in their groups. If the salary example takes the entire period, you can begin class with the "Practice Together" questions below.

Practice Together in Small Groups/Individually

Ask students to work in small groups on the Growth vs. Decay task.

INCLUDED IN THE STUDENT MANUAL

Task #1: Growth vs. Decay

For each of the situations below, set up a table, write a general formula, and sketch a graph to represent the output in terms of the input.

1. North Dakota has recently had the fastest growing population out of all 50 states. On Jan 1, 2013, the population of North Dakota was 700,000 people. North Dakota's population has been growing by 5% per year. Express North Dakota's population, N , in terms of years since 2013, t (use data from your state, if applicable).
2. An air freshener starts with 30 grams of fluid, and the amount of fluid decreases by 12% per day. Express the amount of grams of freshener, Q , that remains t days after it has begun being used.

Solutions:

1. $N = 700,000(1.05)^t$
2. $Q = 30(0.88)^t$

Evaluate Understanding



Hopefully, students will not struggle with problem one, but if they do, refer back to the earlier salary example. Obviously, problem two will be quite different since it is decreasing, not increasing. Students should be able to generalize from their use of repeated reasoning in their approach to problem two.

In a whole-group setting, engage students in a discussion about ways in which the equation for problem two is different than the equation in problem one. Students should recognize that the growth factor, a , is now less than one (but still greater than zero). At this point, we can refer to this value as the **decay rate**. In problem two, the quantity is decreasing by 12% each day. You may need to explain why a decrease of 12% daily is represented in the equation by 0.88.

Ask one group to share their graph and notice how it looks very different. The graph is decreasing at a slower and slower rate as time goes on. Now the graph has a horizontal asymptote as t goes to infinity.

This would be a good time to review growth and decay together. In both cases, we say a quantity is growing (decaying) exponentially if it can be written in the form:

$$Q = Q_0 a^t \text{ for some } a > 0.$$

Q_0 denotes the initial value of the quantity at time $t=0$. It is the vertical intercept; a is the called the growth (decay) factor.

- If $a > 1$, then we have exponential growth. The growth rate $r = a - 1$ is positive. The graph is increasing at a faster and faster rate, and getting closer and closer to zero as t goes to negative infinity.

- If $0 < a < 1$, then we have exponential decay. The growth rate $r = a - 1$ is negative. The graph is decreasing and getting closer and closer to zero as t goes to infinity. The function gets very large as t goes to negative infinity.

Closing Activity

Ask students to work independently on the Linear or Exponential task. Assist students who are still struggling.

INCLUDED IN THE STUDENT MANUAL

Task #2: Linear or Exponential?

1. In (a)–(e), say whether the quantity is changing in a linear or exponential fashion.
 - a. A savings account, which earns no interest, receives a deposit of \$723 per month.
 - b. The value of a machine depreciates by 17% per year.
 - c. Every week, $\frac{9}{10}$ of a radioactive substance remains from the beginning of the week.
 - d. A liter of water evaporates from a swimming pool every day.
 - e. Every 124 minutes, $\frac{1}{2}$ of a drug dosage remains in the body.

(<http://www.illustrativemathematics.org/illustrations/629>)

2. The functions below represent exponential growth or decay. What is the initial quantity? What is the growth rate? Is this growth or decay and how do you know? Make a rough sketch of the graph of the function and write a story problem to go with each equation.
 - a. $P = 8(1.23)^t$
 - b. $Q = 3.1(0.78)^t$
 - c. $y = 3^{t/2}$
 - d. $w = \left(\frac{3}{2}\right)^t$
 - e. $P = 10(3)^{t/2}$

Possible Solutions:

1.
 - a. Assuming no money is being taken out of the account, the account is increasing in a linear fashion because the same amount is added to the account every month.
 - b. The value of the machine decreases by 17% every year. This is the same as saying that the amount, B , gets replaced by $B - 0.17B = 0.83B$. So the value is multiplied every year by a constant factor that is less than 1. Therefore it is decreasing exponentially.
 - c. Each week the quantity of radioactive substances gets multiplied by $\frac{9}{10}$, so it is decreasing exponentially.
 - d. Every day the amount of water in the pool decreases by the same amount, one liter, so it decreases in a linear fashion.
 - e. Every 124 minutes the amount of the drug gets multiplied by $\frac{1}{2}$, so this quantity decreases exponentially.

- 2.
- a. $Q_0=8$; $r = .23$; growth because $r>0$
 - b. $Q_0=3.1$; $r = -.22$; decay because $r<0$
 - c. $Q_0=1$; $r = 2$; growth because $r>0$
 - d. $Q_0=1$; $r = .5$; growth because $r>0$
 - e. $Q_0=10$; $r = 2$; growth because $r>1$

Independent Practice:

If students seem a little weak, assign them more problems similar to one and two in the closing activity with varying degrees of difficulty.

For all other students who are ready to move on, assign them the Population and Food Supply task below.

INCLUDED IN THE STUDENT MANUAL

Task #3: Population and Food Supply

The population of a country is initially two million people and is increasing at a rate of 4% per year. The country's annual food supply is initially adequate for four million people and is increasing at a constant rate adequate for an additional 0.5 million people per year.

- a. Based on these assumptions, in approximately what year will this country first experience shortages of food?
- b. If the country doubled its initial food supply and maintained a constant rate of increase in the supply adequate for an additional 0.5 million people per year, would shortages still occur? In approximately which year?
- c. If the country doubled the rate at which its food supply increases, in addition to doubling its initial food supply, would shortages still occur?

(<http://www.illustrativemathematics.org/illustrations/645>)

Possible Solutions:

- a. We can first express the country's population, $p(t)$, in millions of people, as a function of the time t , measured in years from the initial time. Since we know the initial population $p(0) = 2$ and the annual growth rate is 4%, the $p(t)$ is an exponential function:

$$p(t) = 2(1.04)^t.$$

We are also given that the food supply grows at a constant rate. So we can express the country's food supply at time t , which we call $f(t)$, as a linear function of t . Again, we know the initial value $f(0) = 4$ and the constant rate of change is 0.5 million people per year, so we have:

$$f(t) = 4 + 0.5t$$

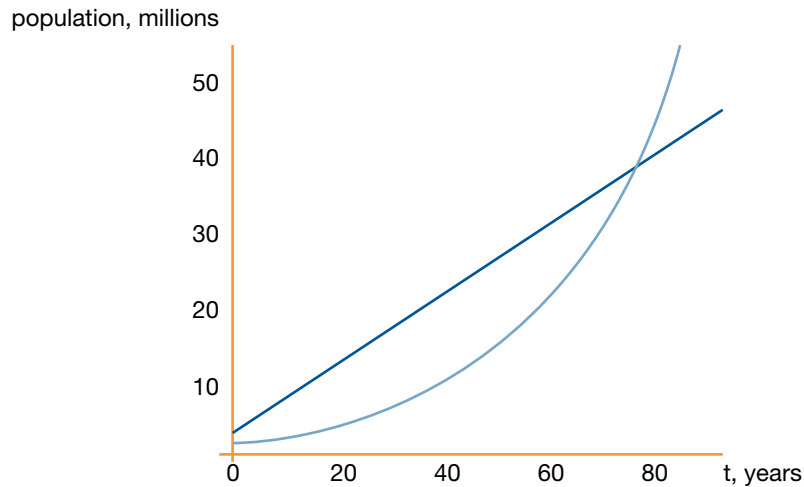

We are looking for the value of t which makes $p(t)$ greater than $f(t)$ for the first time.

We see from the graph that the two functions intersect at around $t=78$. So after 78 years the food supply is just barely enough for the country's population. After this point, however, we see that $p(t) > f(t)$ so this country will first experience shortages of food after approximately 78 years.

- b. If the country doubled its initial food supply, our new functions for the food supply would be

$$h(t) = 8 + 0.5t$$

We would expect food shortages to occur, if at all, later than in part (a).

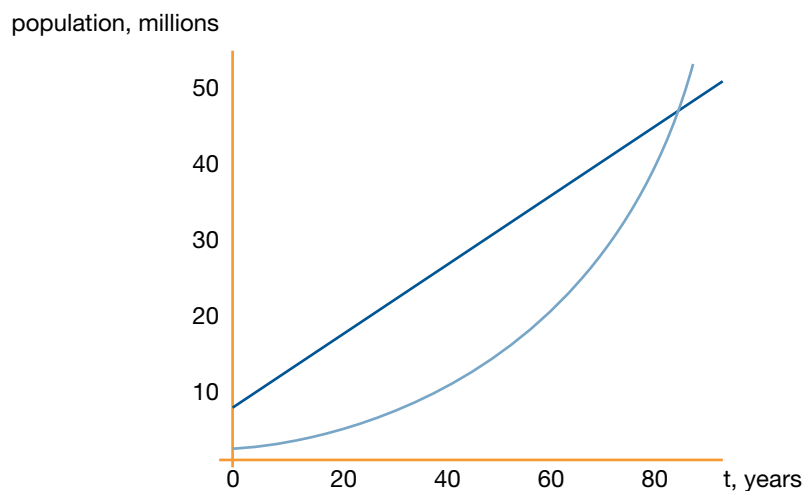

Again, looking at the graph, we see that the two functions intersect, and so food shortages would still occur. We find $p(t) = h(t)$ at roughly $t = 81$. So, the country will first experience food shortages after 81 years. So doubling the initial food supply delays the eventual food shortage by only 3 years.

- c. If the country doubled the rate at which its food supply increases, in addition to doubling its initial food supply, we have the new food supply function:

$$j(t) = 8 + t$$

We would expect, in this case, for food shortages to occur much later than in part (b), if at all.

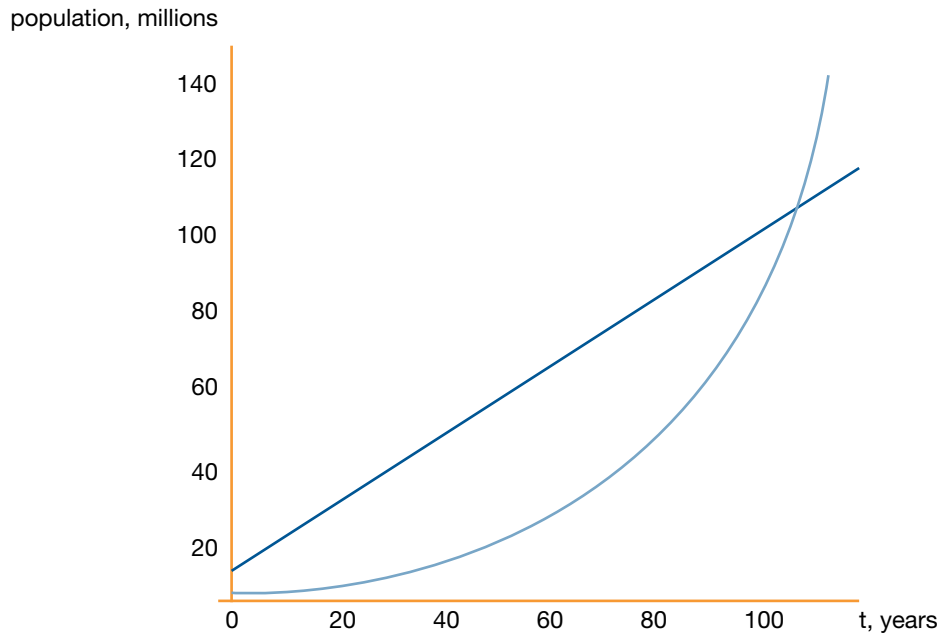

Looking at the graph we see that this time the food shortage occurs at $t = 102$, about 25 years later than in part (a).

Examining the behavior of the exponential function more closely we observe, that the slope of the exponential function keeps increasing whereas the slope of any linear function is constant. Even if a linear function has a very large slope, an exponential function will eventually grow even faster and overtake the linear function.

Resources/Instructional Materials Needed:

- Research ahead of time and be able to provide students with lists and prices of 8-12 local homes on the market, 8-12 vehicles, varying amounts of consumer debt, monthly expenses, and varying amounts of student loans.
- Chart paper

Notes:

Exponential Functions

Lesson 2 of 6

Structure in Exponential Functions

Description:

In this lesson, students examine the patterns in exponential functions and refine their understanding of the components of an exponential function. Attention is given to the structure of an exponential equation and how the structure of equivalent expressions can reveal different key pieces of information. Students will use real life data to model exponential growth situations.

Georgia Standards of Excellence Addressed:

- MGSE9-12.A.SSE.3: Choose and produce an equivalent form of an expression to reveal and explain properties of the quantity represented by the expression.
- MGSE9-12.A.CED.2: Create linear, quadratic, and exponential equations in two or more variables to represent relationships between quantities; graph equations on coordinate axes with labels and scales. (The phrase “in two or more variables” refers to formulas like the compound interest formula, in which $A = P(1 + r/n)^{nt}$ has multiple variables.)
- MGSE9-12.F.IF.4: Using tables, graphs, and verbal descriptions, interpret the key characteristics of a function which models the relationship between two quantities. Sketch a graph showing key features including: intercepts; interval where the function is increasing, decreasing, positive, or negative; relative maximums and minimums; symmetries; end behavior; and periodicity.
- MGSE9-12.F.IF.7e: Graph exponential and logarithmic functions, showing intercepts and end behavior, and trigonometric functions, showing period, midline and amplitude.
- MGSE9-12.F.IF.8b: Use the properties of exponents to interpret expressions for exponential functions. For example, identify percent rate of change in functions such as $y = (1.02)^t$, $y = (0.97)^t$, $y = (1.01)^{(12t)}$, $y = (1.2)^{(t/10)}$ and classify them as representing exponential growth and decay.
- MGSE9-12.F.BF.1a: Determine an explicit expression and recursive process (steps for calculation) from context. For example, if Jimmy starts out with \$15 and earns \$2 a day, the explicit expression “ $2x + 15$ ” can be described recursively (either in writing or verbally) as “to find out how much money Jimmy will have tomorrow, you add \$2 to his total today.” $J_n = J_{n-1} + 2$, $J_0 = 15$
- MGSE9-12.F.LE.1c: Recognize situations in which a quantity grows or decays by a constant percent rate per unit interval relative to another.
- MGSE9-12.F.LE.2: Construct linear and exponential functions, including arithmetic and geometric sequences, given a graph, a description of a relationship, or two input-output pairs (include reading these from a table).

- MGSE9-12.F.LE.5: Interpret the parameters in a linear ($f(x) = mx + b$) and exponential ($f(x) = a \cdot d^x$) function in terms of context. (In the functions above, “m” and “b” are the parameters of the linear function, and “a” and “d” are the parameters of the exponential function.) In context, students should describe what these parameters mean in terms of change and starting value.

Standard(s) for Mathematical Practice Emphasized:

- SMP 4: Model with mathematics.
- SMP 7: Look for and make use of structure.
- SMP 8: Look for and express regularity in repeated reasoning.

Sequence of
Instruction

Activities Checklist

Engage

In small groups of two to four, have students complete number one on the Task #4: Ponzi Pyramid Schemes from Shell Center assessment task E06:
<http://map.mathshell.org/materials/tasks.php?taskid=278&subpage=expert>.

Select and sequence different group’s approaches to number one. The first class presentation should be the most simplistic and end with the most advanced approach. If they exist, include in the presentation groups that illustrate common misconceptions as well. Following the class presentations for number one, the class should discuss numbers two and three on this task.

Current event reference: Ponzi schemes are a “real life” application. A quick internet search can reveal a wealth of information regarding recent Ponzi schemes and public opinion of such schemes. Perhaps most famously in recent years is the case of Bernie Madoff who was sentenced to 150 years in federal prison for a Ponzi scheme related to his wealth management business. Madoff was a Wall Street giant that lost billions of dollars (of other people’s money) in a large scale Ponzi scheme.

INCLUDED IN THE STUDENT MANUAL

Task #4: Ponzi Pyramid Schemes

“Ponzi” Pyramid Schemes



Max has received this email. It describes a scheme for making money.

From: A Crook
Date: Thursday 15th January 2009
To: B Careful
Subject: Get rich quick!

Dear friend,

Do you want to get rich quick? Just follow the instructions carefully below and you may never need to work again:

1. At the bottom of this email there are 8 names and addresses.
Send \$5 to the name at the top of this list.
2. Delete that name and add your own name and address at the bottom of the list.
3. Send this email to 5 new friends.

1. If that process goes as planned, how much money would be sent to Max? Show your calculations.

INCLUDED IN THE STUDENT MANUAL

“Ponzi” Pyramid Schemes: (continued)

2. What could possibly go wrong? Explain your answer clearly.

3. Why do they make Ponzi schemes like this illegal?

Explore



Students should work in small groups for this problem.

INCLUDED IN THE STUDENT MANUAL

Task #5: Snail Invasion

In 1966, a Miami boy smuggled three Giant African Land Snails into the country. His grandmother eventually released them into the garden, and in seven years there were approximately 18,000 of them. The snails are very destructive and had to be eradicated. According to the USDA, it took 10 years and cost \$1 million to eradicate them.

- Assuming the snail population, $P(t)$, grows exponentially, write an expression for it in terms of the number, t , of years since their release.
- By what percent did snail population grow each year?
- By what percent did the snail population grow each month?
- Using a calculator or technology, determine how long does it take for the population to double?
- (Optional for additional challenge) Assuming the cost of eradicating the snails is proportional to the population, how much would it have cost to eradicate them if
 - They had started the eradication program a year earlier?
 - They had let the population grow unchecked for another year?

Adapted from: <http://www.illustrativemathematics.org/illustrations/638>.

Possible Solutions:

- Using the exponential regression feature in a calculator, $P(t) = 3(3.4653)^t$ is an appropriate function model for the snail growth. Since it is assumed that the growth is exponential, the following method can be used as well. It is not expected that all students have this sophisticated level of natural logarithm work but could be seen as a differentiation for students ready to move beyond exponential regression. We are given two data points, namely that $P(0) = 3$ and $P(7) = 18,000$ (This last value is only an approximation.). From the first data point we get $3 = P(0) = ae^{0t}$, so we must have $a = 3$. Then $P(7) = 18,000$ gives $18,000 = 3e^{7r}$. Dividing both sides by 3 and taking the natural logarithm of both sides gives $7r = \ln(6000)$, so $r = \ln(6000) / 7 \approx 1.24$. So $P(t) = 3e^{1.24t}$ for $0 \leq t \leq 7$. We use this function to model the population, bearing in mind that it is based on approximate data.

If students use the exponential regression feature of their calculator (or construct the exponential model using a point-ratio form) they will arrive at $P(t) = 3(3.4653)^t$ as a function model. Both of these expressions for $P(t)$ are equivalent.

- Each year the snail population was multiplied by 3.4653. This is easier to see in the regression model but is close in value to $e^{1.24}$. The percent growth is 247% of the snails each year. (This is an usually high growth rate and may cause some concern for students—it simply means the snails are more than tripling each year.)

- c. A monthly model of the snails would be $P(t) = 3(3.4653)^{t/12}$. Therefore, the monthly growth rate is $(3.4653)^{1/12}$ or 1.109. Similarly, $e^{1.24(t/12)}$ for one month is $e^{1.24(1/12)}$ or 1.109. The percent of snail growth per month is about 11% (.109).
- d. The doubling time is the same no matter what the starting value. It takes the same time for the population to double from 3 to 6, then from 6 to 12, and so on. We calculate the time for the population to double from 3 to 6. So we want to find t such that $6 = 3e^{1.24t}$. Dividing both sides by 3 and taking the natural logarithm of both sides gives $\ln(2) = 1.24t$, so $t \approx 0.56$. It takes just over half a year for the population to double. If students do not have the sophistication of logarithms, they could estimate the doubling time by putting their equation into the calculator and using the table feature to find when the number of snails was equal to 6.
- e. i. After six years, the population is $P(6) = 3e^{1.24(6)} \approx 5100$ or $P(6) = 3(3.4653)^6 \approx 5194$. Answer variation exist in the regression model being rounded. If it costs \$1 million to clean up 18,000 snails, then it would cost $5100 / 18000 \times \$1 \text{ million} \approx \$280,000$ to clean up 5100 snails. This makes sense since the number of snails doubles almost two times per year, so the population (and the cost of dealing with it) should be a little more than $\frac{1}{2}$ what it is in the seventh year.
- ii. After eight years, the population is $P(8) = 3e^{1.24(8)} \approx 61000$. So, since it costs \$1 million to clean up 18,000 snails, it would cost $61000 / 18000 \times \$1 \text{ million} \approx \$3,400,000$ to clean up 61,000 snails. This makes sense since the number of snails doubles almost two times per year, so the number of snails (and the cost of dealing with them) should be a little less than 4 times what it is in the seventh year.

As students work on parts a and b, observe how to discuss finding the growth rate r as there are several approaches, and you will want to call on groups to highlight the different methods that can be used to find the formula. Make sure students pay particular attention to the structure of the equations in each method and that individual approaches are highlighted to the class. Parts a and b allow for a nice review discussion of using the laws of exponents to rewrite expressions to reveal different key pieces of information.

Explanation



At this point, students should be familiar with writing an exponential formula if they are given the initial value and the growth/decay rate using the general form $y = a \cdot b^x$ and understand that the rate (b) is a constant multiplier, thus making the exponential function different from a linear function (constant addition).

This task requires students to find an exponential formula given two points rather than relying on the exponential regression feature of the calculator and should be done as a class discussion. If a group took this approach in the snail problem, use their work. If students took a regression approach to the snail problem, explain the purpose of the following is to figure out a model without using the calculator regression feature.

The following questions could be used to probe student thinking:

- Do two points guarantee an exponential function? Why or why not? What else do you need? *Teacher Note:* Analogous to linear functions, if you are given any two points

on the graph AND you know the situation is exponential in nature, there is a unique formula for the graph.

- What do we know about the snail situation? *Teacher Note:* In this case, we know two points (0, 3) and (7, 18000), where t denotes years since release and P denotes number of Giant African Land Snails. So, we have P_0 , but we need to find r before we can find a general equation.

- How can we use this information and what we know about exponentials to arrive at a function model?
Teacher Note: One method would be as follows: $P(t) = P_0 a^t = 3a^t$ since we know the initial number of snails. Substituting the point (t,P) = (7,18000) into the equation, we can solve for a as follows:

$$18000 = 3a^7 \text{ so } 6000 = a^7,$$

$$\text{and } a = (6000)^{1/7} \text{ approx. } 3.465.$$

So the answer to (a) is $P(t) = 3(3.465)^t$.

t	P(t)
0	
1	
2	
3	
4	
5	
6	
7	18000

Some students may think about this better tabularly, thus arriving at the rate of change in a different way. Encourage students to put the information they know into a table and then use repeated reasoning and the structure of exponential equations to arrive at the fact that 6000 has to be equal to a^7 . A table illustration is provided. Putting all the information together, you arrive at $P(t) = 3(3.465)^t$.

Pose this question to the class, “Does the model $P(t) = 3 \cdot 2^{t/0.56}$ also model the snail population? Explain.” **Teacher note:** The doubling time of the snail population is 0.56. Therefore, every time t goes up by 0.56 years, the snail population doubles (we multiply by 2). Students may have a more general approach, such as substituting in values of t to ensure the outputs for both equations is equivalent. Emphasize that the two formulas, $P(t)=3 \cdot 2^{t/0.56}$ and $P(t)=3(3.465)^t$ are two **equivalent equations**.

Ask students to analyze the structure of each of the following three equivalent expressions (include the Pe^{rt} form if students arrived at this in the beginning or ask if this too is an equivalent expression).

$$P(t) = 3(e^{1.24t})$$

$$P(t) = 3(3.465)^t$$

$$P(t) = 3 \cdot 2^{t/0.56}$$

What does the structure of each expression reveal about the context of the snails?

Teacher Note: The expressions are just two different ways to express the same relationship, analogous to how you can express a quadratic in standard form, factored form, or vertex form depending on the properties of the function we are interested in (the intercepts compared to the vertex). In this case, one form tells us how long it takes a quantity to double, the other form tells us by what percent it is growing each year, the other form uses the natural growth rate of e. Substituting the same value of t into each equation will give the same value (thus, they are equivalent equations).

Practice Together in Small Groups/Individually



Students should work on the following task in small groups.

INCLUDED IN THE STUDENT MANUAL

Task #6: Facebook Users

The number of Facebook users worldwide reached one billion on October 4, 2012. Behind India and China, Facebook would be the third largest country in the world (larger than the US!) On April 24, 2012 there were 800 million Facebook users worldwide. Find a formula for the total number of Facebook users, N (in billions of users), t days after Jan 1, 2012. This means January 1 is $t=0$, January 2 is $t=1, \dots$, and December 31 is $t=365$. (Note 2012 was a leap year which is why December 31 is $t=365$. In a non-leap year December 31 is $t=364$).

Possible Solutions:

$$N = N_0 a^t$$

Using the points (114, 0.8) and (277, 1), we have the following two equations:

$0.8 = N_0 a^{114}$ and $1 = N_0 a^{277}$. There are various ways to simultaneously solve these two equations. For example divide them both.

$$0.8/1 = a^{114}/a^{277} = a^{-163}$$

$$\text{Thus } a = (0.8)^{-1/163} = 1.00137.$$

The number of Facebook users was growing by about 0.137% each day.

Next we can find the initial number of Facebook users on January 1, 2012 (when $t = 0$), by substituting the coordinates of one of the points back into the equation to solve for N_0 .

$$0.8 = N_0 (1.00137)^{114} \text{ so } N_0 = 0.8 * (1.00137)^{-114} = 0.684 \text{ billion Facebook users. So}$$

$$N(t) = 0.684(1.00137)^t$$

You can also point out if you leave $N_0 = 0.8 * (1.00137)^{-114}$, then the formula would be

$N(t) = (0.8 * (1.00137)^{-114})(1.00137)^t$ and by properties of exponents, we could write this as

$$N(t) = 0.8 (1.00137)^{t-114}$$

As with the previous example with doubling time, we see we have found two equivalent ways to represent this function. Ask students what information we can readily infer from each form of the equation. Lead them to observe they both tell us the number of users was growing by 0.137% each day. From one, we can see the initial value when $t = 0$ was 0.685 billion users on January 1, 2012. From the other, we can see the value when $t = 114$, $N = 0.8$. This means on April 24, 2012 there were 0.8 billion Facebook users.

Evaluate Understanding

The two problems below may be used to check students' current understanding of exponential functions. Use the results from these problems to determine if any additional practice needs to be provided on this topic.

INCLUDED IN THE STUDENT MANUAL

Task #7: Forms of Exponential Expressions

Four physicists describe the amount of a radioactive substance, Q in grams, left after t years:

- $Q = 300e^{-0.0577t}$
- $Q = 300\left(\frac{1}{2}\right)^{t/12}$
- $Q = 300 \times 0.9439^t$
- $Q = 252.290 \times (0.9439)^{t-3}$

- Show that the expressions describing the radioactive substance are all equivalent (using appropriate rounding).
- What aspect of the decay of the substance does each of the formulas highlight?

Adapted from: <http://www.illustrativemathematics.org/illustrations/1305>.

Possible Solutions:

- Using properties of exponents we can transform the expressions that describe the amount of the radioactive substance into each other. We have

$$300e^{-0.0577t} = 300(e^{-0.0577})^t = 300(0.9439)^t.$$

Similarly,

$$300 \times \left(\frac{1}{2}\right)^{t/12} = 300\left(\left(\frac{1}{2}\right)^{1/12}\right)^t = 300 \times 0.9439^t.$$

Finally,

$$252.290 \times 0.9439^{t-3} = 252.290 \times 0.9439^{-3} \times 0.9439^t = 300 \times 0.9439^t.$$

- The first three formulas show that the initial amount of the substance is 300 grams. This formula lets us read off the fact that the continuous decay rate is 5.77%. (Note: The substance decays at a rate that is proportional to the amount present at any time and the constant of proportionality is 0.0577.) If we substitute $t=12$, we get $Q = 300 \times \left(\frac{1}{2}\right)$. Therefore, this formula shows that the half-life of the substance is 12 years. Since $1 - 0.9439 = 0.0561$ we see from this formula that the annual decay rate is 5.61%. In addition to the annual decay rate, this formula also shows that when $t = 3$ we have $Q=252.290$. This means that after 3 year there are 252.290 grams of the substance left.

INCLUDED IN THE STUDENT MANUAL

Task #8: Exponential Functions

The figure below shows the graphs of the exponential functions $f(x) = c \cdot 3^x$ and $g(x) = d \cdot 2^x$, for some numbers $c > 0$ and $d > 0$. They intersect at the point (p, q) .

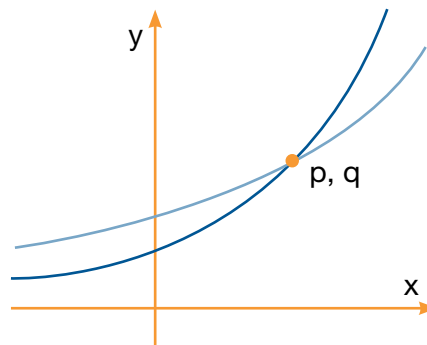

- Which is greater, c or d ? Explain how you know.
- Imagine you place the tip of your pencil at (p, q) and trace the graph of g out to the point with x -coordinate $p + 2$. Imagine I do the same on the graph of f . What will be the ratio of the y -coordinate of my ending point to the y -coordinate of yours?

(<http://www.illustrativemathematics.org/illustrations/351>)

Possible Solutions:

- The graph of $f(x) = c \cdot 3^x$ is steeper than the graph of $g(x) = d \cdot 2^x$ because the value of $f(x)$ triples each time x is increased by one while the value of $g(x)$ doubles each time x is increased by one. Hence the graph of f is the one that intersects the y -axis at a lower value. The graph of f meets the y axis at $f(0) = c \cdot 3^0 = c$ while the graph of g meets the y -axis at $g(0) = d \cdot 2^0 = d$. We conclude that c is greater.
- Along the graph of g each increase of one unit in the x value multiplies the output of g by 2. So an increase of two units in the x value multiplies the output of g by 4. Similarly, an increase of two units in the x value will multiply the value of f by $3^2 = 9$. So the ratio of my y -coordinate to your y -coordinate at our ending points is $\frac{9}{4}$.

Closing Activity

To close, engage students in a whole-group discussion focused on any misconceptions that may have arisen from the previous problems. Make sure students are able to recognize patterns in exponential functions and understand the components of an equation used to model such a function.

Independent Practice Suggestions:

Allow students to work independently on the Illegal Fish task.

INCLUDED IN THE STUDENT MANUAL

Task #9: Illegal Fish

A fisherman illegally introduces some fish into a lake, and they quickly propagate. The growth of the population of this new species (within a period of a few years) is modeled $P(x) = 5b^x$, where x is the time in weeks following the introduction and b is a positive unknown base.

- Exactly how many fish did the fisherman release into the lake?
- Find b if you know the lake contains 33 fish after eight weeks. Show step-by-step work.
- Instead, now suppose that $P(x) = 5b^x$ and $b = 2$. What is the weekly percent growth rate in this case? What does this mean in every-day language?

(<http://www.illustrativemathematics.org/illustrations/579>)

Possible Solutions

- The fisherman released the fish into the lake at time zero, $t = 0$, the exact moment of introduction. Thus, the number of fish that the fisherman released into the lake is given by:

$$P(0) = 5b^0$$

$$P(0) = 5 \times 1$$

$$P(0) = 5$$

This means that the fisherman released 5 fish into the lake.

- We know that x is the time in weeks following the introduction. Let us assume that 2 months is approximately 8 weeks, giving $t = 8$. Then, if the lake contains 33 fish after two months, or $P(8) = 33$, we can solve for b :

$$33 = 5b^8$$

$$b^8 = \frac{33}{5}$$

$$b = \left(\frac{33}{5}\right)^{\frac{1}{8}}$$

$$b \approx 1.266$$

Thus, b is approximately equal to 1.2 if the lake contains 33 fish after two months.

The “weekly percent growth rate” is the percent increase of the population in one week. Since $b = 2$, we know that the population at any time x is given by $P(x) = 5 \times 2^x$, and that the population one week later is given by

$$P(x+1) = 5 \times 2^{x+1} = (5 \times 2^x) \times 2 = 2P(x).$$

We learn that the population doubles each week, which is to say that there is a 100% weekly growth rate.

Exponential Functions

Lesson 3 of 6

Compound Interest

Description:

In lesson three, students extend their study of exponential functions into applications of calculating interest. Along with an examination of different ways interest is compounded, students also experience the long-term effects of what can appear to be a small difference in interest.

College Readiness State Standards Addressed:

- MGSE9-12.A.SSE.3: Choose and produce an equivalent form of an expression to reveal and explain properties of the quantity represented by the expression.
- MGSE9-12.A.CED.4: Rearrange formulas to highlight a quantity of interest using the same reasoning as in solving equations. Examples: Rearrange Ohm’s law $V = IR$ to highlight resistance R ; Rearrange area of a circle formula $A = \pi r^2$ to highlight the radius.
- MGSE9-12.F.LE.1c: Recognize situations in which a quantity grows or decays by a constant percent rate per unit interval relative to another.
- MGSE9-12.F.LE.2: Construct linear and exponential functions, including arithmetic and geometric sequences, given a graph, a description of a relationship, or two input-output pairs (include reading these from a table).
- MGSE9-12.F.LE.5: Interpret the parameters in a linear ($f(x) = mx + b$) and exponential ($f(x) = a \cdot d^x$) function in terms of context. (In the functions above, “ m ” and “ b ” are the parameters of the linear function, and “ a ” and “ d ” are the parameters of the exponential function.) In context, students should describe what these parameters mean in terms of change and starting value.

Standards for Mathematical Practice(s) Emphasized:

- SMP 2: Reason abstractly and quantitatively.
- SMP 3: Construct viable arguments and critique the reasoning of others.
- SMP 4: Model with mathematics.
- SMP 6: Attend to precision.

Sequence of
Instruction

Activities Checklist

Engage



Pose the following task to small groups (two to four students) to complete a mini-presentation to be shared among groups of what payment plan (with justification) they will choose. In this task, students are asked to construct a mathematical model from contextualized information. Students will have to decontextualize the mathematics to arrive at a valid justification of the financing option chosen.

While the problem states a “certain car” for “20,000” you may wish to make this problem more relevant to the students by using the actual selling price of a car.

INCLUDED IN THE STUDENT MANUAL

Task #10: Buying a Car

You wish to purchase a certain car. Two dealerships in town are selling the car for \$20,000. Both dealerships are unique in unusual finance offers. Rather than monthly payments, you are charged interest over time, yet you are expected to pay the car off (plus interest) in one lump sum payment at a date of your choosing. The dealerships don’t want to deal with paper work and are really only interested in “loaning” you money with interest. However, each offers a different payment plan. You have discretion of when you want to pay off this car.

- A. No down payment needed or payments in the first year. When you do pay for the car, you will make one full payment for the car plus any interest accrued. This plan comes with a 12% interest/per year charge.
- B. No down payment needed. No fees or penalties for not making payments. Again, you will make one full payment for the car plus any interest accrued. This plan charges 1% interest per month.

As a group, decide what plan is better for your unique needs. Your presentation to your peers should include details about how much you will have to pay off at different times and how your group arrived at the decisions you made.

Possible solutions to this task are included in the explanation section.

Explore



Ask students to work in their groups to consider this question. After the group has agreed on a solution, ask them to show or explain their reasoning on a large piece of chart paper. Ask one member of each group to switch with a member of another group. The remaining group members explain their reasoning, then everyone returns to original groups and perhaps some groups will want to change their answers. Listen carefully to assure that students are constructing viable arguments and that they are able to explain when they see flaws in others’ arguments.

Explanation



It is likely to see groups use tables for the monthly interest and formulas for the annual interest (or maybe just tables or just equations).

For Option A:

$$A(t) = 20,000(1.12)^t \text{ so when } t = 1 \text{ year we have a payment of } A(1) = \$22,400$$

For Option B:

x (months)	B(x)
0	20,000
1	$20,000(1.01) = 20,200$
2	$20,000(1.01)^2 = 20,812$
...	...
12	$20,000(1.01)^{12} = 22,537$

Thus the 12% annual interest is a better deal IF students plan to pay off the car in one year.

Make sure that students recognize that while 1% over 12 months seems to be the same as 12% because $1 + 1 + 1$, etc. would add to 12% these two rates are not the same.

Ask students why 1% interest each month for 12 months is not the same as 12% interest?

Teacher Note: 1% each month for 12 months is not the same as 12% interest once a year because each month you are being charged interest on the interest, and that is why the payment was larger with payment plan B. In the payment plan B, we say the interest is being **compounded monthly**.

Pose the following questions, attending to the precision of the language (for example monthly vs. annual, factor vs. rate) both you and the students use when discussing:

Effectively, how much interest is payment plan B charging per year?

Teacher Note: After one year, we have applied the **monthly growth factor** 1.01 repeatedly 12 times. In other words, the **annual growth factor** is $22,537/20,000 = (1.01)^{12} = 1.127$. **Thus, the annual growth rate** is $1.127 - 1 = 0.127 = 12.7\%$.

So charging 12.7% interest each year and charging 1% interest each month are the same at the end of each year. And we can see practically from this example as well as algebraically below that we have equivalent ways of expressing the same relationship.

$$B(t) = 20,000(1.127)^t = 20,000[(1.01)^{12}]^t = 20,000(1.01)^{12t}$$

Discuss the following with real life applications with students:

Credit cards often quote the interest they charge in two different ways, **nominal annual percentage rate (APR)** and an **effective annual rate (EAR)**. The example above illustrates the difference in these two ways of describing how the interest is charged. You can now show students examples of actual ads for credit cards or cars that quote APR interest rates. Below is a screenshot taken from creditcards.org. Illustrate how companies barrage consumers with tons of information, and it can be quite confusing even when you know the math how to determine which credit cards are best for you. Almost all credit cards quote the interest rate as an APR as shown below.

Chase Freedom® MasterCard - \$100 Bonus Cash Back

- » 0% Intro APR for 15 months on purchases and balance transfers
- » Earn \$100 Bonus Cash Back after you make \$500 in purchases in your first 3 months from account opening
- » 5% Cash Back on up to \$1,500 spent between Jan 1 and Mar 31, 2013 at gas stations, drugstores and Starbucks® stores
- » You'll enjoy new 5% categories every 3 months like gas stations, restaurants and Amazon.com. It's free and easy to activate your bonus each quarter!
- » Unlimited 1% Cash Back on all other purchases
- » No annual fee and rewards never expire

Intro APR Purchases	Intro APR Balance Transfer	Regular APR	Annual Fee	Credit Needed
0%-15 mths*	0%-15 mths*	12.99%-22.99% (Variable)*	\$0*	Excellent Credit*

Bank Americard Travel Rewards® Credit Card

- » Earn flexible travel points good for everything from flights to baggage fees
- » Earn 1.5 points for every dollar spent on purchases - 50% more than the average rewards programs which only offer 1 point per dollar
- » 10,000 bonus points offer - that can be \$100 off your next travel purchase!
- » No annual fee
- » No limit to the total number of points you can earn and points don't expire
- » Simply pay for your travel with your card. Then, call or go online and you can redeem your points for a statement credit towards all or part of your travel purchases
- » No foreign transaction fees
- » Chip Technology provides you expanded global acceptance when shopping anywhere you go, outside of the U.S.

Intro APR Purchases	Intro APR Balance Transfer	Regular APR	Annual Fee	Credit Needed
0%-12 billing cycles*	N/A*	14.99%-22.99% Variable*	\$0*	Excellent Credit*

*Regular APR applies to both purchases and balance transfers

Capital One® VentureOne™ Rewards

- » 0% Intro APR on purchases until February 2014
- » 1.25 miles per dollar on every purchase, every day and no annual fee

Ask students to calculate the EAR (effective annual rate) of an advertised APR of 12%.

Teacher Note: For an APR of 12% means each month, an interest rate of $12\%/12 = 1\%$ is applied to the balance. Based on the previous example, we say an APR of 12% has an effective annual rate (or EAR) of 12.7%.

You may want to remind your students have already answered similar questions in working with exponential growth (of Facebook users for example). This is not an entirely new topic, rather another application of the same topic, exponentials.

Ask students, “Does an APR of 12% versus an EAR of 12.7% really make that much of a difference? Calculate the difference in 12.7% versus 12% for 30 years on an initial value of \$20,000.”

Teacher Note: Charging 12.7% interest per year for 30 years on the value of the \$20,000 car would lead to a charge of about \$722,350, as compared to charging 12% each year for 30 years which would cost \$599,198. The seemingly small difference is HUGE – or \$123,152.

Discuss with students.

Since there are so many terms, this would be a good time to define some terminology and notation.

Let B_0 denote the initial balance.

Let r denote the APR (also called the nominal interest rate).

Let n denote the number of times interest is compounded in a year ($n = 12$ in our example).
Let t denote the number of years since charging the initial balance B_0 .

In general, the balance, B , t years later will be $B(t) = B_0(1+r/n)^{nt}$.

Teacher Note: It is important that students see where this formula comes from first through an example, so they understand “why” the formula is so. If students do not see “why”, go back through the example or try a similar example. Now we see why credit card companies almost always quote the APR and almost never quote the EAR. The APR will always *sound* less than the EAR.

Practice Together in Small Groups/Individually



Students should complete the following problems in a small group setting.

INCLUDED IN THE STUDENT MANUAL

Task #11: Part 1: Saving for College

When you invest money in a bank account (and add interest to your balance), the same terminology and notation applies. For example, imagine parents of a newborn baby want to invest money today in order to pay for the child’s college 18 years from now. They have \$10,000 of savings they wish to deposit all at once into one savings account, which they will withdraw from 18 years from now.

- A. Bank A advertises an APR of 6% with monthly compounding. (Think about how much of this interest is applied monthly.)
- B. Bank B advertises an EAR of 6%. This means 6% interest is accrued once each year.

Which bank has the better savings account? Create a model that shows what plan the parents should choose in order to save the maximum amount possible for college.

Possible Solutions:

$$A(t) = 10,000(1+0.06/12)^{12t}, \text{ so } A(18) = 10,000(1+0.06/12)^{12 \cdot 18} = \$29,367.66$$

$$B(t) = 10,000(1.06)^t, \text{ so } B(18) = 10,000(1.06)^{18} = \$28,543.39$$

If students don’t make this comment themselves, then say \$28,543.39 is not going to be able to pay for four years worth of college 18 years from now.

INCLUDED IN THE STUDENT MANUAL

Part 2: Saving for College with the End in Mind

Imagine the parents wish to have \$150,000 in account A in 18 years, how much would they need to deposit today?

Possible Solutions:

$$150,000 = B_0(1.005)^{(12 \cdot 18)} \text{ solving for } B_0 = 150000 / (1.005)^{(12 \cdot 18)} = \$51,076.60$$

In other words, they need to make a lump sum deposit of \$51,076.60 today in order to have \$150,000 18 years in the future. For this reason, we call \$51,076.60 the **present value (denoted PV)** of \$150,000 18 years in the future. Similarly, we say \$150,000 is the **future value (denoted FV)** in 18 years of \$51,076.60 today. Rewriting $B(t) = B_0(1+r/n)^{nt}$

using this notation we therefore have

$$FV = PV \cdot (1 + r/n)^{nt}$$

In our example, we had $FV = 150000$, $r = 0.06$, $n = 12$, and $t = 18$. We solved for PV .

Evaluate Understanding

INCLUDED IN THE STUDENT MANUAL

Task #12: Buying on Credit

If you charge \$500 on a credit card today, how much will the balance be in two years (assuming no additional fees) if the credit card has a 10% APR that is compounded—

- once a year?
- once a month?
- once a week?

If you need \$25,000 eight years from now, what is the minimum amount of money you need to deposit into a bank account that pays an annual percentage rate (APR) of 5% that is compounded—

- once a year?
- once a month?
- once a day?

Possible Solutions:

\$500 credit card balance in two years:

- Compounded yearly: \$605.
- Compounded monthly ($n = 12$): \$610.20.
- Compounded weekly ($n = 52$): \$610.58.

Need \$25,000 in eight years:

- Compounded yearly: \$16,920.98.
- Compounded monthly ($n = 12$): \$16,771.93.
- Compounded daily ($n = 365$): \$16,758.46.

Closing Activity

Conclude with a whole-group discussion on the two problems in the Evaluate Understanding section focusing specifically on the different ways in which interest is compounded.

Independent Practice:

If you run out of time, assign Evaluate Understanding questions to be worked on at home. It is easy to create some of your own questions similar to the Evaluate Understanding questions above if you think your students would benefit from further practice.

To assure students understand the structure of the formulas, ask them to work independently on The Bank Account problem.

INCLUDED IN THE STUDENT MANUAL

Task #13: The Bank Account

Most savings accounts advertise an annual interest rate, but they actually compound that interest at regular intervals during the year. That means that, if you own an account, you'll be paid a portion of the interest before the year is up, and, if you keep that payment in the account, you will start earning interest on the interest you have already earned.

For example, suppose you put \$500 in a savings account that advertises 5% annual interest. If that interest is paid once per year, then your balance B after t years could be computed using the equation $B = 500(1.05)^t$, since you'll end each year with 100% + 5% of the amount you began the year with.

On the other hand, if that same interest rate is compounded monthly, then you would compute your balance after t years using the equation:

$$B = 500\left(1 + \frac{0.05}{12}\right)^{12t}$$

- Why does it make sense that the equation includes the term $\frac{0.05}{12}$? That is, why are we dividing 0.05 by 12?
- How does this equation reflect the fact that you opened the account with \$500?
- What do the numbers 1 and $\frac{0.05}{12}$ represent in the expression $\left(1 + \frac{0.05}{12}\right)$?
- What does the "12t" in the equation represent?

(<http://www.illustrativemathematics.org/illustrations/390>)

Possible Solutions:

- The 5% is the annual interest rate. Since this interest is compounded monthly (12 times per year), the rate needs to be divided by 12 to figure out the monthly interest rate.
- Looking at the structure of the expression on the right side of the equation, you can see that \$500 starting value is multiplied by a factor that depends on the interest rate and the amount of time that has passed. If you let $t = 0$, you will find the amount in the account after zero years have passed:

$$B = 500\left(1 + \frac{0.05}{12}\right)^{12(0)} = 500(1) = 500.$$

In other words, the coefficient of the exponential expression corresponds to the initial amount in the account.

- Each month the value of the account is multiplied by $\left(1 + \frac{0.05}{12}\right)$ so if we begin a month with D dollars, we end the month with:

$$\left(1 + \frac{0.05}{12}\right)D = 1 \times D + \frac{0.05}{12}D.$$

Now it's clear that the 1 represents the (100% of the) money in the account at the start of the month, and the $\frac{0.05}{12}$ represents the percentage of D that gets added in at the end of the month, (i.e., the monthly interest rate).

Exponential Functions

Lesson 4 of 6

Formative Assessment Lesson: Comparing Investments

Description:

This lesson is intended to help you assess how well students are able to interpret exponential and linear functions. Students will translate between descriptive, algebraic and tabular data and graphical representation of the functions and will also be asked to recognize how, and why, a quantity changes per unit interval. To achieve these goals students work on simple and compound interest problems.

Georgia Standards of Excellence Addressed:

- MGSE9-12.A.SSE.1: Interpret expressions that represent a quantity in terms of its context.
- MGSE9-12.A.SSE.1a: Interpret parts of an expression, such as terms, factors and coefficients, in context.
- MGSE9-12.A.SSE.1b: Given situations which utilize formulas or expressions with multiple terms and/or factors, interpret the meaning (in context) of individual terms or factors.
- MGSE9-12.A.SSE.2: Use the structure of an expression to rewrite it in different equivalent forms. For example, see $x^4 - y^4$ as $(x^2)^2 - (y^2)^2$, thus recognizing it as a difference of squares that can be factored as $(x^2 - y^2)(x^2 + y^2)$.
- MGSE9-12.A.SSE.3: Choose and produce an equivalent form of an expression to reveal and explain properties of the quantity represented by the expression.
- F.MGSE9-12.F.LE.1: Distinguish between situations that can be modeled with linear functions and with exponential functions.
- MGSE9-12.F.LE.1a: Show that linear functions grow by equal differences over equal intervals and that exponential functions grow by equal factors over equal intervals. (This can be shown by algebraic proof, with a table showing differences or by calculating average rates of change over equal intervals.)
- MGSE9-12.F.LE.1b: Recognize situations in which one quantity changes at a constant rate per unit interval relative to another.
- MGSE9-12.F.LE.1c: Recognize situations in which a quantity grows or decays by a constant percent rate per unit interval relative to another.

Standard(s) for Mathematical Practice Emphasized:

- SMP 1: Make sense of problems and persevere in solving them.
- SMP 2: Reason abstractly and quantitatively.
- SMP 4: Model with mathematics.
- SMP 7: Look for and make use of structure.

Sequence of
Instruction

Activities Checklist

Shell Center Formative Assessment Lesson

Comparing Investments:

<http://map.mathshell.org/materials/lessons.php?taskid=426&subpage=concept>.

What is the purpose of this formative assessment lesson?

“The concept development lessons are designed to be used by teachers every few weeks, over one or two class periods depending on how the school has organized mathematics instruction. They may be used in the middle of a curriculum unit on the topic, to gauge and improve students’ level of understanding, and/or they can be used later in the year as review and support.”

(<http://map.mathshell.org/materials/background.php?subpage=formative>.)

The following *Formative Assessment Lesson* is a classroom-ready lesson included to help teachers assess and improve students’ understanding of mathematical concepts and skills and their ability to use the “mathematical practices” described in the College Readiness Standards. Research has shown that formative assessment, as embodied in the following lesson, is a powerful way to improve student learning and performance. This approach first allows students to demonstrate their prior understandings and abilities in employing the mathematical processes, and then resolve their own difficulties and misconceptions through structured discussion. This results in more secure long-term learning, reducing the need for re-teaching that otherwise takes so much classroom time. Many often ask, why don’t students just remember the procedures they have been taught and practiced? The fact is, that approach works fine in the short term but, as every teacher knows, if procedural knowledge is not underpinned by conceptual understanding, students will quickly forget “how to do it.” Read more about the *Formative Assessment Lesson* rationale, structure, and philosophy using the *Brief Guide for Teachers and Administrators* that can be found at <http://map.mathshell.org/materials/index.php>.

CONCEPT DEVELOPMENT



Mathematics Assessment Project
CLASSROOM CHALLENGES
A Formative Assessment Lesson

Comparing Investments

Mathematics Assessment Resource Service
University of Nottingham & UC Berkeley
Beta Version

For more details, visit: <http://map.mathshell.org>
© 2012 MARS, Shell Center, University of Nottingham
May be reproduced, unmodified, for non-commercial purposes under the Creative Commons license detailed at <http://creativecommons.org/licenses/by-nc-nd/3.0/> - all other rights reserved

BEFORE THE LESSON

Assessment task: *Making Money?* (20 minutes)

Ask the students do this task, in class or for homework, a day or more before the lesson. This will give you an opportunity to assess their work, and to find out the kinds of difficulties they have with it. You should then be able to target your help more effectively in the follow-up lesson.

Give each student a copy of the assessment task, *Making Money?* Introduce the task briefly, and help the class to understand the context.

Why do we put money in a bank? [To keep it safe and gain interest.]

What does interest mean? [The money the bank adds to the investment.]

What is an interest rate? [The percentage by which the money grows each year. This is often called the APY 'Annual Percentage Yield'.]

Can you see why the \$200 in Simply Savings grows to \$220 after one year?

Spend 15 minutes on your own, reading through the questions and trying to answer them as carefully as you can.

It is important that, as far as possible, students are allowed to answer the questions without your assistance. Students should not worry too much if they cannot understand or do everything because, in the next lesson, they will engage in a similar task that should help them. Explain to students that by the end of the next lesson, they should expect to be able to answer questions like these confidently. This is their goal.

Assessing students' responses

Collect student's responses to the task, and make some notes on what their work reveals about their current levels of understanding. The purpose of doing this is to forewarn you of any difficulties students may experience during the lesson itself, so that you can prepare carefully.

We suggest that you do not score students' work. Research shows that this will be counterproductive as it will encourage students to compare their scores, and will distract their attention from the mathematics. Instead, help students to make further progress by summarizing their difficulties as a list of questions. Some suggestions for these are given in the *Common issues* table on the next page.

We suggest you make a list of your own questions, based on your students' work. We recommend you either:

Making Money?

Mary is going to invest some money. She sees two advertisements:

Simply Savings Bank Simple interest rate: 10% per year.	Compound Capital Bank Compound interest rate: 8% per year.
---	--

1. Mary invests \$200 in each bank. Use a calculator to figure how much she will have in each bank at the end of each year. Show all your work.

Years	Value at Simply Savings in dollars	Value at Compound Capital in dollars
0	200.00	200.00
1	220.00	
2		
3		
4		
5		

2. Which of the graphs below best shows how Mary's money will grow in each bank?

Graph A



Graph B

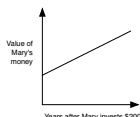

Graph C

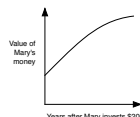

(a) The growth of her money at Simply Savings is best shown by graph

(b) The growth of her money at Compound Capital is best shown by graph

(c) If you think that none of these graphs are a good description, explain why below:
.....
.....

3. Write down a formula for calculating the amount of money in each of these banks after n years.
.....
.....
.....

4. Mary wants to invest some money for 5 years or more. Which bank should she choose? Give full reasons for your answer.
.....
.....
.....

- Write one or two questions on each student’s work, or
- Give each student a printed version of your list of questions and highlight appropriate questions for individual students.

If you do not have time to do this, you could select a few questions that will be of help to the majority, and write these on the board when you return the work to the students.

Common issues:

Suggested questions and prompts:

<p>Student assumes simple interest for both investments (Q1, Q2)</p> <p>For example: Student makes the Compound Capital investment grow by \$16 per year. Or: Student selects graph B for both banks (Q2)</p>	<ul style="list-style-type: none"> • Can you explain the difference between compound interest and simple interest? • For the investment in Compound Capital, what is the amount in the bank at the end of the first year? What will be the interest after one year? Can you explain why the interest changes for the second year?
<p>Student figures out the interest on \$100 (Q1)</p> <p>For example: Student writes the Year 1 value of the savings at Compound Capital as \$208.</p>	<ul style="list-style-type: none"> • What is 8% of \$200?
<p>Student writes a general formula (Q3)</p> <p>For example: $A = P + \frac{RP}{100}$ or $A = P\left(1 + \frac{R}{100}\right)^n$</p>	<ul style="list-style-type: none"> • Can you write a formula that includes the interest rates for each of the banks?
<p>Student writes the formula incorrectly (Q3)</p> <p>For example: $A = 200 + 10n$; $A = 200 \times 10n$ (Simply Savings.) $A = 200 + 1.08^n$; $A = 200 \times 8n$ (Compound Capital.)</p>	<ul style="list-style-type: none"> • How can you check your answer? • Try substituting values of n into your formula to check your answers.
<p>Student assumes that Simply Savings will always be a better investment (Q4)</p>	<ul style="list-style-type: none"> • Which is the better investment after 5 years? • Which is the better investment after 6/7/8 years? How do you know? • What will happen to the difference in amounts over a longer period of time?
<p>Inefficient method (Q4)</p> <p>For example: Instead of using a formula, the student compounds the interest each year.</p>	<ul style="list-style-type: none"> • Can you think of a quicker method for calculating the amount of money in the bank after say, 10 years?
<p>Completes the task</p> <p>The student needs an extension task.</p>	<ul style="list-style-type: none"> • How long would it take each savings plan to double your investment? • Does this doubling time depend on the size of the initial investment? Why, or why not? • What would Mary get from each plan if she took out her money after 6 months?

SUGGESTED LESSON OUTLINE

Whole-class interactive introduction (15 minutes)

Give each student a calculator, a mini-whiteboard, a pen, and an eraser.

Today we will investigate two ways to invest money: simple interest and compound interest.

What is the difference between simple and compound interest? [Simple interest calculates a percentage of the original investment amount and adds it on each year. Compound interest calculates a percentage of the amount in the account.]

To introduce simple interest, show Slide P-1 of the projector resource.

Odd One Out?
Investment 1 \$100 Simple Interest Rate: 5%
Investment 2 \$400 Simple Interest Rate: 5%
Investment 3 \$200 Simple Interest Rate: 10%

Look at these three investments. Which is the odd one out?

Write down your reasoning on your mini-whiteboards.

Ask one or two students to explain their answers. Most students will answer that Investment 3 is the odd one out because it has a different interest rate. Prompt them to consider other possibilities:

I think Investment 1 is the odd one out. Why do I think this? [Investment 1 will increase by \$5 a year, whereas Investments 2 and 3 will both increase by \$20 a year.]

Ask students to explain their answers. If students are struggling to answer the question, ask:

Investment 1 and 2 have the same interest rate, does this mean the investments will increase by the same amount each year? How much will each investment increase by each year?

Now ask the students to represent the description of an investment algebraically.

How can you represent Investment 2 as a formula? Start the formula with $A = \dots$, where A is the amount in the bank. Use n to represent the number of years the money is invested.

Allow students a few minutes to think about the question individually and then ask them to discuss the problem with a partner before sharing ideas with the whole class. (We sometimes refer to this as the 'think-pair-share' strategy.)

Ask students to show you their formula using their mini-whiteboards. Ask students with different answers to justify them. Encourage the rest of the class to challenge these explanations.

Look for students that use the interest rate in their formula, instead of interest: e.g. $A = 400 + 5n$ or $A = 400 + 0.05n$

Can you use your formula to figure out how much is in the bank after 5 years?

Can you check this answer by using the description of the investment plan?

To introduce compound interest, show Slide P-2 of the projector resource.

Odd One Out?

Investment 1
 $A = 500 \times 1.06^4$

Investment 2
 $A = 250 \times 1.06^2$

Investment 3
 $A = 500 \times 1.03^2$

In each expression, A shows the value of an amount of money that has been invested for a given period of time.

How do you know that these represent compound interest, not simple interest?

What does each expression mean?

Which is the odd one out? Write down your reason on your mini-whiteboards.

Encourage students to discuss this and then ask a few with different answers to justify them. Students may reason that:

- Investment 1 is the odd one out because the money is invested over a longer period than the other two investments.
- Investment 2 is the odd one out because the initial investment is different from the other two investments.
- Investment 3 is the odd one out because the interest rate is different from the other two investments.

Try to make sure that students can see the significance of each number in the expression by asking specific questions:

What is the initial investment?

How long is the money invested for?

What is the interest rate?

Encourage students to justify their answers. Look out for students that assume the interest rate is 1.06% or 1.03%.

Can you use your calculator to work out the amount of money in each investment, after the specified period? [Investment 1: $A = \$631.24$; Investment 2: $A = \$280.90$; Investment 3: $A = \$530.45$.]

Collaborative activity 1: Card Set: Investment Plans and Formulas (10 minutes)

Organize students into groups of two or three.

Give each group cut-up *Card Set: Investment Plans and Formulas*.

You have two sets of cards, one with descriptions of investment plans and one with the formulas. Some of the investment plans use simple interest and some use compound interest.

Using what you have learned from our discussion, take it in turns to match a formula with a corresponding investment plan.

There are two spare investment plan cards. Write on the blank cards the formula for these two plans.

Some students may not be able to match all the cards. Later in the lesson they will be given more cards that should help them to complete all of the matches.

Card Set: Investment Plans and Formulas	
P1 Investment: \$400 Simple Interest Rate: 16%	P2 Investment: \$400 Compound Interest Rate: 2%
P3 Investment: \$400 Simple Interest Rate: 8%	P4 Investment: \$200 Compound Interest Rate: 2%
P5 Investment: \$400 Compound Interest Rate: 8%	P6 Investment: \$400 Simple Interest Rate: 2%
F1 $A = 400 \times 1.08^n$	F2 $A = 400 + 32n$
F3 $A = 400 \times 1.02^n$	F4 $A = 400 + 8n$
F5 	F6

Whilst students work on the collaborative activity you have two tasks: to notice students' approaches and difficulties and to support student reasoning:

Note different student approaches to the task

Listen and watch students carefully. Are they matching the cards correctly? Do students within a group use the same strategies for matching the cards? Are they starting with an investment plan and looking for a formula that matches or are they interpreting the formula and then linking this with the description of the plan? How do students go about completing the blank cards? Do they refer to their already matched cards and if so, which ones? Notice whether students are addressing the difficulties they experienced in the assessment task. You may want to use the questions in the *Common issues* table to help address misconceptions.

Support student reasoning

Try not to make suggestions that move students towards a particular approach to the task. Instead, ask questions that help students to clarify their thinking. It is important that students are encouraged to engage with their partner's explanations, and take responsibility for each other's understanding.

Pippa, you matched these two cards. Gita, can you explain why Pippa matched these cards?

Encourage students to think about how the formula relates to the investment plan:

[Select a formula card.] For each year, will the interest change or remain the same? How can you check your answer is correct?

Can you explain what the number 400 relates to in this formula?

How can you work out the amount in the bank for this investment plan/formula after say, 3 years?

[Select a formula card.] If you substitute a value for n into this formula what do you get?

[Select an investment plan card of a simple interest investment.]

How can you calculate the interest made each year for this plan? How is this represented in a formula?

[Select a formula card.] What can you tell me about the interest rate or the interest for this investment?

Some students may assume that for simple interest, the interest added each year is the coefficient of n .

What does 32 represent in this formula? [Card F2: the amount of interest added each year.]

How can you check this? Is this the same as the interest rate?

What is the formula for an investment of \$100 and a simple interest rate of 8%?

How can you check that your answer is correct?

How does the formula change if the investment is \$200/\$400?

Collaborative activity 2: Card Set: Graphs and Card Set: Tables (15 minutes)

As the groups finish matching the cards give them cut-up *Card Sets: Graphs and Tables*. These cards should help students check their existing matches.

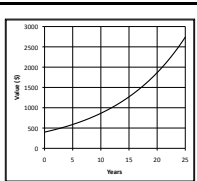
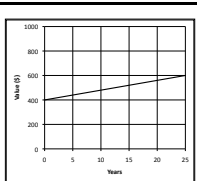
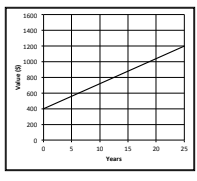
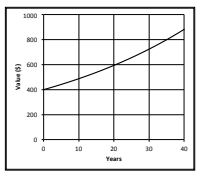
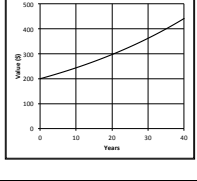
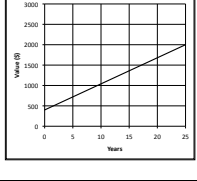
Card Set: Graphs		Card Set: Tables																													
G1 	G2 	T1 <table border="1" style="margin: auto;"><thead><tr><th>Years</th><th>Value (\$)</th></tr></thead><tbody><tr><td>0</td><td>400.00</td></tr><tr><td>1</td><td>432.00</td></tr><tr><td>2</td><td>466.56</td></tr><tr><td>3</td><td></td></tr><tr><td>4</td><td>544.20</td></tr><tr><td>5</td><td>587.73</td></tr></tbody></table>	Years	Value (\$)	0	400.00	1	432.00	2	466.56	3		4	544.20	5	587.73	T2 <table border="1" style="margin: auto;"><thead><tr><th>Years</th><th>Value (\$)</th></tr></thead><tbody><tr><td>0</td><td>200.00</td></tr><tr><td>1</td><td>204.00</td></tr><tr><td>2</td><td></td></tr><tr><td>3</td><td>212.24</td></tr><tr><td>4</td><td>216.49</td></tr><tr><td>5</td><td>220.82</td></tr></tbody></table>	Years	Value (\$)	0	200.00	1	204.00	2		3	212.24	4	216.49	5	220.82
Years	Value (\$)																														
0	400.00																														
1	432.00																														
2	466.56																														
3																															
4	544.20																														
5	587.73																														
Years	Value (\$)																														
0	200.00																														
1	204.00																														
2																															
3	212.24																														
4	216.49																														
5	220.82																														
G3 	G4 	T3 <table border="1" style="margin: auto;"><thead><tr><th>Years</th><th>Value (\$)</th></tr></thead><tbody><tr><td>0</td><td>400.00</td></tr><tr><td>1</td><td>408.00</td></tr><tr><td>2</td><td></td></tr><tr><td>3</td><td>424.00</td></tr><tr><td>4</td><td>432.00</td></tr><tr><td>5</td><td>440.00</td></tr></tbody></table>	Years	Value (\$)	0	400.00	1	408.00	2		3	424.00	4	432.00	5	440.00	T4 <table border="1" style="margin: auto;"><thead><tr><th>Years</th><th>Value (\$)</th></tr></thead><tbody><tr><td>0</td><td>400.00</td></tr><tr><td>1</td><td>408.00</td></tr><tr><td>2</td><td></td></tr><tr><td>3</td><td>424.48</td></tr><tr><td>4</td><td>432.97</td></tr><tr><td>5</td><td>441.63</td></tr></tbody></table>	Years	Value (\$)	0	400.00	1	408.00	2		3	424.48	4	432.97	5	441.63
Years	Value (\$)																														
0	400.00																														
1	408.00																														
2																															
3	424.00																														
4	432.00																														
5	440.00																														
Years	Value (\$)																														
0	400.00																														
1	408.00																														
2																															
3	424.48																														
4	432.97																														
5	441.63																														
G5 	G6 	T5 <table border="1" style="margin: auto;"><thead><tr><th>Years</th><th>Value (\$)</th></tr></thead><tbody><tr><td>0</td><td>400.00</td></tr><tr><td>1</td><td>432.00</td></tr><tr><td>2</td><td>464.00</td></tr><tr><td>3</td><td></td></tr><tr><td>4</td><td>528.00</td></tr><tr><td>5</td><td>560.00</td></tr></tbody></table>	Years	Value (\$)	0	400.00	1	432.00	2	464.00	3		4	528.00	5	560.00	T6 <table border="1" style="margin: auto;"><thead><tr><th>Years</th><th>Value (\$)</th></tr></thead><tbody><tr><td>0</td><td>400.00</td></tr><tr><td>1</td><td>464.00</td></tr><tr><td>2</td><td></td></tr><tr><td>3</td><td>592.00</td></tr><tr><td>4</td><td>656.00</td></tr><tr><td>5</td><td>720.00</td></tr></tbody></table>	Years	Value (\$)	0	400.00	1	464.00	2		3	592.00	4	656.00	5	720.00
Years	Value (\$)																														
0	400.00																														
1	432.00																														
2	464.00																														
3																															
4	528.00																														
5	560.00																														
Years	Value (\$)																														
0	400.00																														
1	464.00																														
2																															
3	592.00																														
4	656.00																														
5	720.00																														

Now match the Graphs and Tables cards with the cards already matched.

You must also calculate the missing value in each table.

Observe the different strategies that students use as they do this and encourage them to try different methods, and to draw links between the different representations. Try to avoid making all the connections for the students.

Some may think about the shapes of the graphs or the differences between rows in the tables:

Can you separate these graphs and tables into those that represent simple interest and those that represent compound interest? [Some are linear and some are exponential.]

Which investments go up by equal amounts each year and which go up by increasing amounts each year? How does the plan/formula/table/graph show this? What does this tell you about the investment plan?

In trials, some students called the non-linear curves ‘quadratic’. You may need to help your students distinguish between quadratic and exponential functions.

Some students may substitute into an equation (e.g. $n = 0$ or $n = 25$) and check if the answer matches a point on one of the graphs.

John you used substitution to calculate the value of the investment after 25 years. Can you now think of a different method? [Students could compare slopes of two graphs.]

Some students may assume that the slope represents the interest rate.

[Select a linear graph card.] What does the slope of this graph represent? [The interest added each year. The slope can be calculated by multiplying the simple interest rate by the amount invested.]

When students have completed the task, ask them to check their work against that of a neighboring group.

Check to see which matches are different from your own.

If there are differences, ask for an explanation. If you still don't agree, explain your own thinking.

You may then need to consider whether to make any changes to your own work.

It is important that everyone in both groups understands the math.

You are responsible for each others' learning.

Collaborative activity 3: Card Set: Statements (20 minutes)

Give each group cut-up *Card Set: Statements*, a large sheet of paper for making a poster, and a glue stick.

In your groups you are now going to match one of these statements to the cards already on your desk.

Statement Card S1 matches two sets of cards.

You may need to explain to students that the phrase ‘return for your money’ means the interest gained for each \$100 originally invested.

Students may find it helpful to sketch the graphs for two different plans onto the same set of axes when comparing investments. They can use their mini-whiteboards to do this.

Card Set: Statements	
S1 These two investments will take the same time to double your money.	S2 This investment will double your money in 12 years 6 months.
S3 This investment gives the worst return for your money over two years or more.	S4 This investment is the best one over 10 years.
S5 This investment is the best one over 20 years.	

Encourage students to check their matches. For example, if they use graphs to match the statements, ask:

Chris, you used this graph card to match this statement. Can you now use a different card to check your pairing is correct?

When students have completed the task, ask them to glue the cards down on to their poster paper, writing next to the cards an explanation for the matched cards.

Once you have investigated the statement and are happy with your findings, glue the statement and investment plans on to your poster.

Add reasons for all your matches.

Completed posters may look something like this:

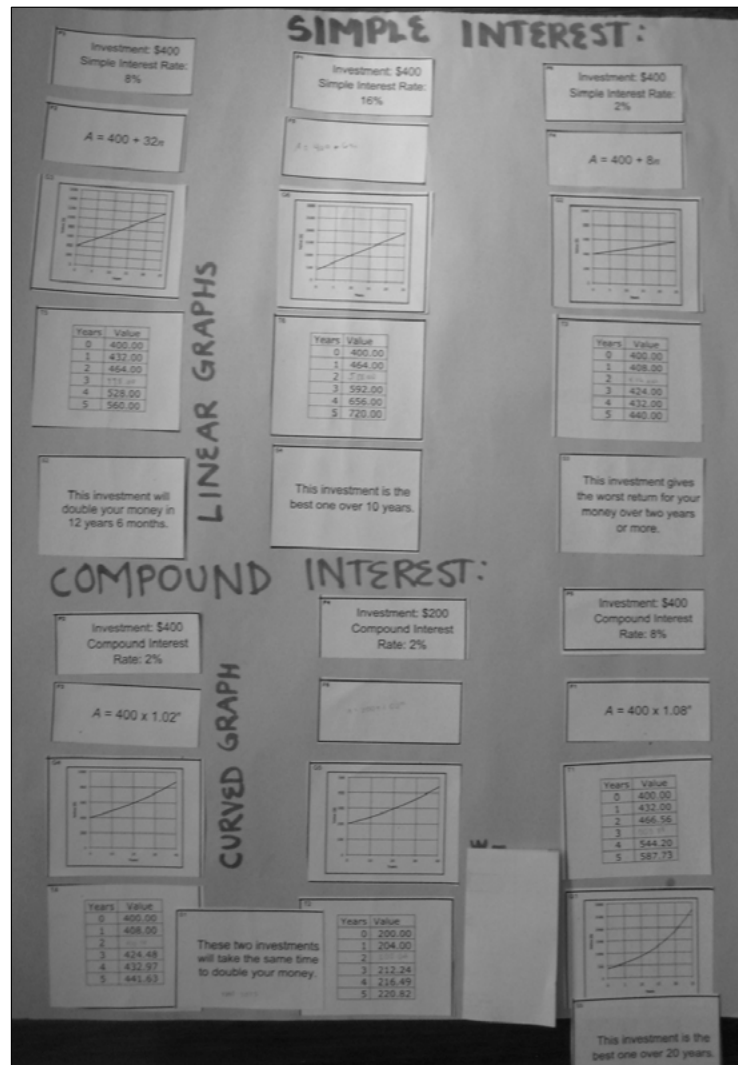

Whole-class discussion (10 minutes)

Organize a whole-class discussion about different strategies used to match the cards. You may, first, want to select a set of cards that most groups matched correctly. This approach can encourage good explanations. Then select one or two cards that most groups found difficult to match. Ask other students their views on which method is easiest to follow, as well as contributing ideas of alternative approaches.

If there is time, you may like to consider the following extension: *Double Your Money*.

Show Slide P-3 of the projector resource:

Double Your Money	
Investment 1 $A = 500 \times 1.06^n$	Which two investments will take exactly the same time to double the money?
Investment 2 $A = 250 \times 1.06^n$	
Investment 3 $A = 500 \times 1.03^n$	

At the start of the lesson, we noted that Investment 1 and Investment 3 invest the same amount of money, and Investment 1 and 2 have same interest rate. Now try to answer the question [Investments 1 and 2 will double the money in the same time, as they have the same interest rate.]

Ask students to write their answers on their mini-whiteboards.

After a few minutes ask students with different answers to justify them. Encourage other students to challenge their explanations.

Does it matter how much money is invested? [No.]

How can you answer the question without doing any calculations?

In order to double your money, what should 1.06^n equal? [2]

Show me two different compound investment plans that take the same time to double your money.

Show me two different compound interest investment plans that take different times to double your money. Which one would double your money first? How do you know?

Students who are confident using the formula could be encouraged to provide an algebraic solution. For example, to show that doubling any amount of money takes the same amount of time, writing the starting amount as x and the final amount as $2x$ gives the equation $(1.06^n)x = 2x$, the x 's cancel out, leaving the same equation to be solved each time ($1.06^n = 2$).

Some students may ask how to find the value of n . If you have time, and you think your students will understand, you may want to explain how logarithms can be used to make n the subject of the equation.

Now show Slide P-4 of the projector resource:

Double Your Money	
<p style="text-align: center;">Investment 1</p> <p style="text-align: center;">$A = 500 + 20n$</p>	<p>Which two investments will take exactly the same time to double the money?</p>
<p style="text-align: center;">Investment 2</p> <p style="text-align: center;">$A = 200 + 8n$</p>	
<p style="text-align: center;">Investment 3</p> <p style="text-align: center;">$A = 200 + 20n$</p>	

For Investment 1, what is the value of A when the initial investment is doubled? [\$1000.]

*Does the time it takes to double your money depend on how much money is invested? [The time it takes to double your money for simple interest investments = Amount Invested ÷ Interest. If the **interest rates** are the same, then it does not matter how much money is invested.]*

Can you think of a quick way to answer the question?

Show me two different simple interest investment plans that take the same time to double your money.

Show me two different simple interest investment plans that take different times to double your money. Which one would double your money first? How do you know?

Follow-up lesson: Revisiting Making Money? and reflecting on learning (20 minutes)

Return their original assessment task to the students together with a copy of *Making Money?* (revisited).

If you have not added questions to individual pieces of work, then write your list of questions on the board. Students should select from this list only those questions they think are appropriate to their own work.

Read through your solutions to Making Money? and the questions I have asked.

Using what you have learned, try to answer the questions on the new task Making Money? (revisited).

Some teachers give this as a homework task.

Extension

One natural extension to this work would be to consider how much an investment will pay if it is withdrawn part way through a year. This leads to a consideration of the continuity of the growth function.

For example, if the annual compound interest rate is 8%, then:

$$\text{Approximate value after } n \text{ years} = A \times (1.08)^n = A \times (1.08^{\frac{1}{12}})^{12n}$$

Replacing $12n$ by m , this gives:

$$\text{Value after } m \text{ months} = A \times (1.0064)^m$$

SOLUTIONS

Assessment Task: Making Money?

- | Years | Value at Simply Savings (\$) | Value at Compound Capital (\$) |
|-------|------------------------------|--------------------------------|
| 0 | 200.00 | 200.00 |
| 1 | 220.00 | 216.00 |
| 2 | 240.00 | 233.28 |
| 3 | 260.00 | 251.94 |
| 4 | 280.00 | 272.10 |
| 5 | 300.00 | 293.87 |
- The growth of her money at Simply Savings is best shown by graph B.
 - The growth of her money at Compound Capital is best shown by graph A.
 - Students may reason that if the interest is only added at the end of the year, then the graph would have discrete steps. These graphs assume that interest is added continuously.
- $A = 200 + 20n$; $A = 200 \times 1.08^n$.
- For the first five investment years Simply Savings Bank is the better plan, however at the end of Year 7 Compound Capital starts to perform better (\$342.76 compared to \$340.) Compound Capital is a better investment for savers wanting to invest for 7 years or more.

Assessment Task: Making Money? (revisited)

- | Years | Value at Compound Investments (\$) | Value at Simple Investments (\$) |
|-------|------------------------------------|----------------------------------|
| 0 | 300.00 | 300.00 |
| 1 | 315.00 | 318.00 |
| 2 | 330.75 | 336.00 |
| 3 | 347.29 | 354.00 |
| 4 | 364.65 | 372.00 |
| 5 | 382.88 | 390.00 |
- The growth of her money at Compound Investments is best shown by graph C.
 - The growth of her money at Simple Investments is best shown by graph B.
 - Students may reason that if the interest is only added at the end of the year, then the graph would have discrete steps. These graphs assume that interest is added continuously.
- $A = 300 \times 1.05^n$; $A = 300 + 18n$.
- For the first five investment years Simple Investments is the better plan, however at the end of Year 9 Compound investments starts to perform better (\$465.40 compared to \$462.00.) Compound Investments is a better investment scheme for savers wanting to invest for 9 years or more.

Collaborative Activity

The parts in **bold** are to be provided by the student.

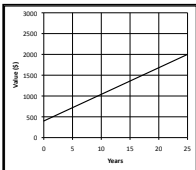
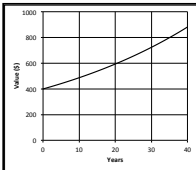
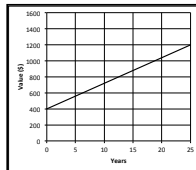
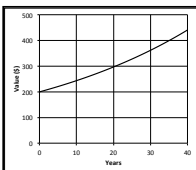
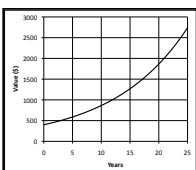
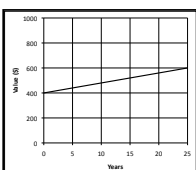
<p>P1 Investment: \$400 Simple Interest Rate: 16%</p>	<p>F6 $A = 400 + 64n$</p>	<p>G6 </p>	<p>T6 <table border="1" data-bbox="964 449 1187 638"> <thead> <tr> <th>Years</th> <th>Value</th> </tr> </thead> <tbody> <tr><td>0</td><td>400.00</td></tr> <tr><td>1</td><td>464.00</td></tr> <tr><td>2</td><td>528.00</td></tr> <tr><td>3</td><td>592.00</td></tr> <tr><td>4</td><td>656.00</td></tr> <tr><td>5</td><td>720.00</td></tr> </tbody> </table> </p>	Years	Value	0	400.00	1	464.00	2	528.00	3	592.00	4	656.00	5	720.00	<p>S4 This investment is the best one over 10 years.</p>
Years	Value																	
0	400.00																	
1	464.00																	
2	528.00																	
3	592.00																	
4	656.00																	
5	720.00																	
<p>P2 Investment: \$400 Compound Interest Rate: 2%</p>	<p>F3 $A = 400 \times 1.02^n$</p>	<p>G4 </p>	<p>T4 <table border="1" data-bbox="964 674 1187 863"> <thead> <tr> <th>Years</th> <th>Value</th> </tr> </thead> <tbody> <tr><td>0</td><td>400.00</td></tr> <tr><td>1</td><td>408.00</td></tr> <tr><td>2</td><td>416.16</td></tr> <tr><td>3</td><td>424.48</td></tr> <tr><td>4</td><td>432.97</td></tr> <tr><td>5</td><td>441.63</td></tr> </tbody> </table> </p>	Years	Value	0	400.00	1	408.00	2	416.16	3	424.48	4	432.97	5	441.63	<p>S1 (P2 and P4) These two investments will take the same time to double your money.</p>
Years	Value																	
0	400.00																	
1	408.00																	
2	416.16																	
3	424.48																	
4	432.97																	
5	441.63																	
<p>P3 Investment: \$400 Simple Interest Rate: 8%</p>	<p>F2 $A = 400 + 32n$</p>	<p>G3 </p>	<p>T5 <table border="1" data-bbox="964 907 1187 1096"> <thead> <tr> <th>Years</th> <th>Value</th> </tr> </thead> <tbody> <tr><td>0</td><td>400.00</td></tr> <tr><td>1</td><td>432.00</td></tr> <tr><td>2</td><td>464.00</td></tr> <tr><td>3</td><td>496.00</td></tr> <tr><td>4</td><td>528.00</td></tr> <tr><td>5</td><td>560.00</td></tr> </tbody> </table> </p>	Years	Value	0	400.00	1	432.00	2	464.00	3	496.00	4	528.00	5	560.00	<p>S2 This investment will double your money in 12 years 6 months.</p>
Years	Value																	
0	400.00																	
1	432.00																	
2	464.00																	
3	496.00																	
4	528.00																	
5	560.00																	
<p>P4 Investment: \$200 Compound Interest Rate: 2%</p>	<p>F5 $A = 200 \times 1.02^n$</p>	<p>G5 </p>	<p>T2 <table border="1" data-bbox="964 1140 1187 1329"> <thead> <tr> <th>Years</th> <th>Value</th> </tr> </thead> <tbody> <tr><td>0</td><td>200.00</td></tr> <tr><td>1</td><td>204.00</td></tr> <tr><td>2</td><td>208.08</td></tr> <tr><td>3</td><td>212.24</td></tr> <tr><td>4</td><td>216.49</td></tr> <tr><td>5</td><td>220.82</td></tr> </tbody> </table> </p>	Years	Value	0	200.00	1	204.00	2	208.08	3	212.24	4	216.49	5	220.82	<p>S1 (P2 and P4) These two investments will take the same time to double your money.</p>
Years	Value																	
0	200.00																	
1	204.00																	
2	208.08																	
3	212.24																	
4	216.49																	
5	220.82																	
<p>P5 Investment: \$400 Compound Interest Rate: 8%</p>	<p>F1 $A = 400 \times 1.08^n$</p>	<p>G1 </p>	<p>T1 <table border="1" data-bbox="964 1373 1187 1562"> <thead> <tr> <th>Years</th> <th>Value</th> </tr> </thead> <tbody> <tr><td>0</td><td>400.00</td></tr> <tr><td>1</td><td>432.00</td></tr> <tr><td>2</td><td>466.56</td></tr> <tr><td>3</td><td>503.88</td></tr> <tr><td>4</td><td>544.20</td></tr> <tr><td>5</td><td>587.73</td></tr> </tbody> </table> </p>	Years	Value	0	400.00	1	432.00	2	466.56	3	503.88	4	544.20	5	587.73	<p>S5 This investment is the best one over 20 years.</p>
Years	Value																	
0	400.00																	
1	432.00																	
2	466.56																	
3	503.88																	
4	544.20																	
5	587.73																	
<p>P6 Investment: \$400 Simple Interest Rate: 2%</p>	<p>F4 $A = 400 + 8n$</p>	<p>G2 </p>	<p>T3 <table border="1" data-bbox="964 1606 1187 1795"> <thead> <tr> <th>Years</th> <th>Value</th> </tr> </thead> <tbody> <tr><td>0</td><td>400.00</td></tr> <tr><td>1</td><td>408.00</td></tr> <tr><td>2</td><td>416.00</td></tr> <tr><td>3</td><td>424.00</td></tr> <tr><td>4</td><td>432.00</td></tr> <tr><td>5</td><td>440.00</td></tr> </tbody> </table> </p>	Years	Value	0	400.00	1	408.00	2	416.00	3	424.00	4	432.00	5	440.00	<p>S3 This investment gives the worst return for your money over two years or more.</p>
Years	Value																	
0	400.00																	
1	408.00																	
2	416.00																	
3	424.00																	
4	432.00																	
5	440.00																	

Making Money?

Mary is going to invest some money. She sees two advertisements:

Simply Savings Bank
Simple interest rate: 10% per year.

Compound Capital Bank
Compound interest rate: 8% per year.

1. Mary invests \$200 in each bank.
Use a calculator to figure how much she will have in each bank at the end of each year.
Show all your work.

Years	Value at Simply Savings in dollars	Value at Compound Capital in dollars
0	200.00	200.00
1	220.00	
2		
3		
4		
5		

2. Which of the graphs below best shows how Mary's money will grow in each bank?

Graph A

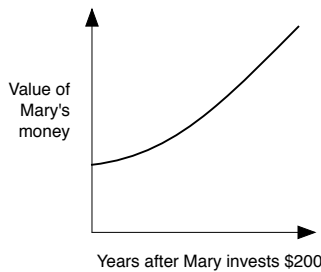

Graph B

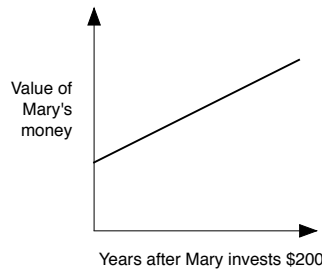

Graph C

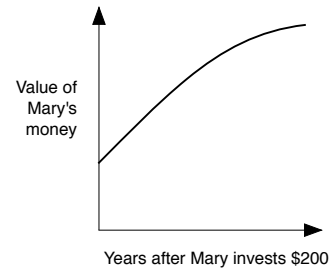

- (a) The growth of her money at Simply Savings is best shown by graph
- (b) The growth of her money at Compound Capital is best shown by graph
- (c) If you think that none of these graphs are a good description, explain why below:

.....

.....

.....

3. Write down a formula for calculating the amount of money in each of these banks after n years.

.....
.....
.....
.....
.....

4. Mary wants to invest some money for 5 years or more.
Which bank should she choose?
Give full reasons for your answer.

.....
.....
.....
.....
.....
.....
.....

Making Money? (revisited)

Jack is going to invest some money. He sees two advertisements:

Compound Investments
Compound interest rate: 5% per year.

Simple Investments
Simple interest rate: 6% per year.

1. Jack invests \$300 in each scheme.
Use a calculator to figure how much he will have in each scheme at the end of each year.
Show all your work.

Years	Value at Compound Investments (\$)	Value at Simple Investments (\$)
0	300.00	300.00
1		
2		
3		
4		
5		

2. Which of the graphs below best shows how Jack's money will grow in each bank?

Graph A

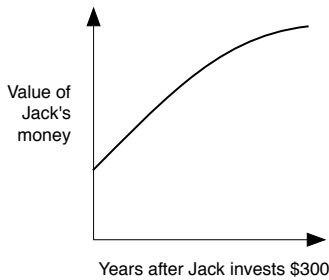

Graph B

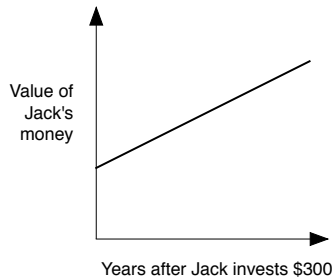

Graph C

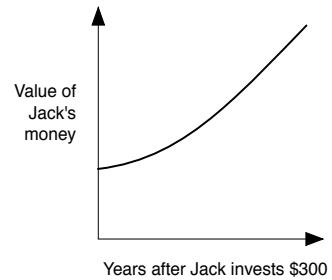

- (a) The growth of his money at Compound Investments is best shown by graph
- (b) The growth of his money at Simple Investments is best shown by graph
- (c) If you think that none of these graphs are a good description, explain why below:

.....

.....

.....

3. Write down a formula for calculating the amount of money in each of these schemes after n years.

.....
.....
.....
.....
.....

4. Jack wants to invest some money for 5 years or more.
Which scheme should he choose?
Give full reasons for your answer.

.....
.....
.....
.....
.....
.....

Card Set: Investment Plans and Formulas

P1 Investment: \$400 Simple Interest Rate: 16%	P2 Investment: \$400 Compound Interest Rate: 2%
P3 Investment: \$400 Simple Interest Rate: 8%	P4 Investment: \$200 Compound Interest Rate: 2%
P5 Investment: \$400 Compound Interest Rate: 8%	P6 Investment: \$400 Simple Interest Rate: 2%

F1 $A = 400 \times 1.08^n$	F2 $A = 400 + 32n$
F3 $A = 400 \times 1.02^n$	F4 $A = 400 + 8n$
F5	F6

Card Set: Graphs

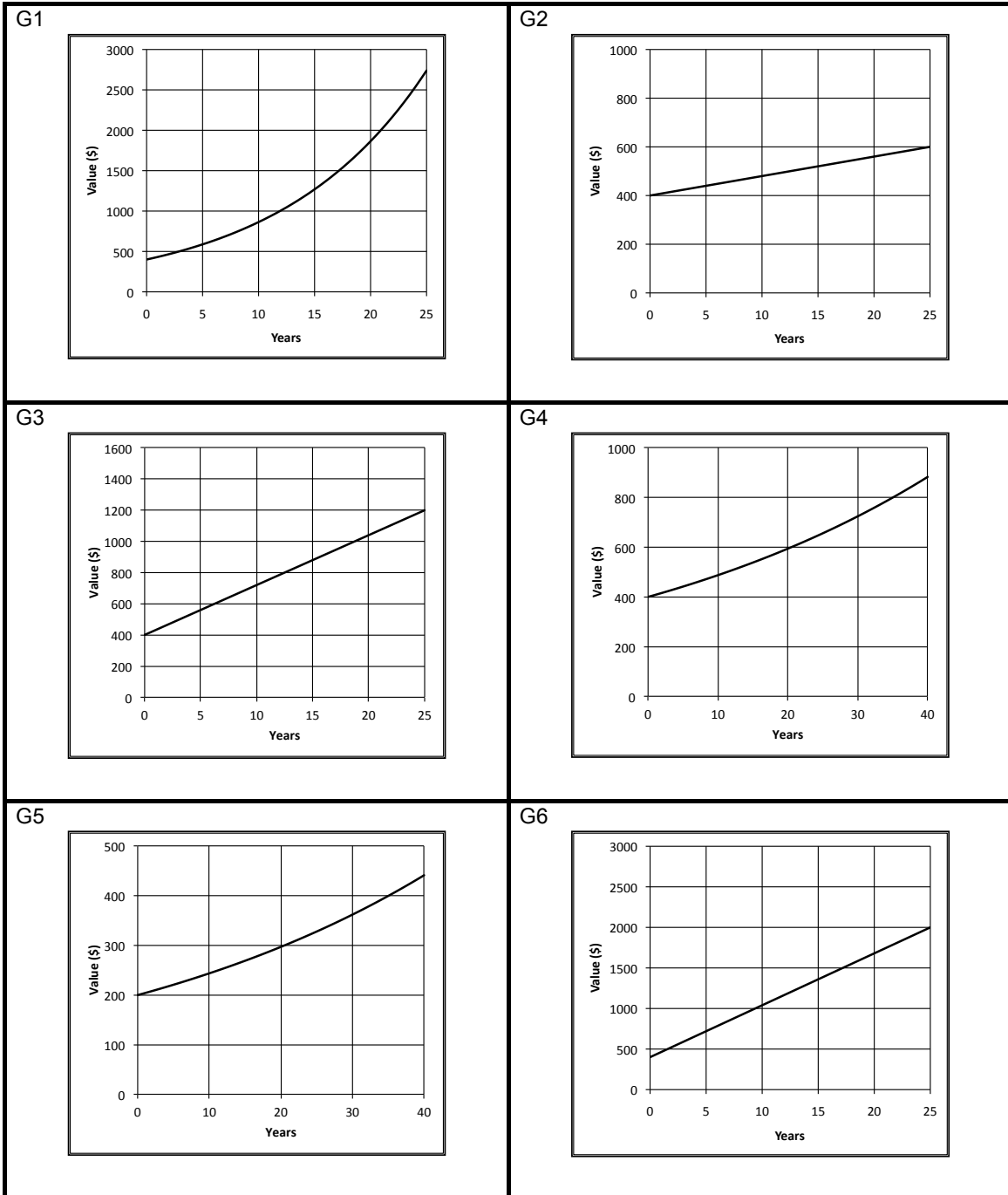

Card Set: Tables

T1	<table border="1"> <thead> <tr> <th>Years</th> <th>Value (\$)</th> </tr> </thead> <tbody> <tr><td>0</td><td>400.00</td></tr> <tr><td>1</td><td>432.00</td></tr> <tr><td>2</td><td>466.56</td></tr> <tr><td>3</td><td></td></tr> <tr><td>4</td><td>544.20</td></tr> <tr><td>5</td><td>587.73</td></tr> </tbody> </table>	Years	Value (\$)	0	400.00	1	432.00	2	466.56	3		4	544.20	5	587.73	T2	<table border="1"> <thead> <tr> <th>Years</th> <th>Value (\$)</th> </tr> </thead> <tbody> <tr><td>0</td><td>200.00</td></tr> <tr><td>1</td><td>204.00</td></tr> <tr><td>2</td><td></td></tr> <tr><td>3</td><td>212.24</td></tr> <tr><td>4</td><td>216.49</td></tr> <tr><td>5</td><td>220.82</td></tr> </tbody> </table>	Years	Value (\$)	0	200.00	1	204.00	2		3	212.24	4	216.49	5	220.82
Years	Value (\$)																														
0	400.00																														
1	432.00																														
2	466.56																														
3																															
4	544.20																														
5	587.73																														
Years	Value (\$)																														
0	200.00																														
1	204.00																														
2																															
3	212.24																														
4	216.49																														
5	220.82																														
T3	<table border="1"> <thead> <tr> <th>Years</th> <th>Value (\$)</th> </tr> </thead> <tbody> <tr><td>0</td><td>400.00</td></tr> <tr><td>1</td><td>408.00</td></tr> <tr><td>2</td><td></td></tr> <tr><td>3</td><td>424.00</td></tr> <tr><td>4</td><td>432.00</td></tr> <tr><td>5</td><td>440.00</td></tr> </tbody> </table>	Years	Value (\$)	0	400.00	1	408.00	2		3	424.00	4	432.00	5	440.00	T4	<table border="1"> <thead> <tr> <th>Years</th> <th>Value (\$)</th> </tr> </thead> <tbody> <tr><td>0</td><td>400.00</td></tr> <tr><td>1</td><td>408.00</td></tr> <tr><td>2</td><td></td></tr> <tr><td>3</td><td>424.48</td></tr> <tr><td>4</td><td>432.97</td></tr> <tr><td>5</td><td>441.63</td></tr> </tbody> </table>	Years	Value (\$)	0	400.00	1	408.00	2		3	424.48	4	432.97	5	441.63
Years	Value (\$)																														
0	400.00																														
1	408.00																														
2																															
3	424.00																														
4	432.00																														
5	440.00																														
Years	Value (\$)																														
0	400.00																														
1	408.00																														
2																															
3	424.48																														
4	432.97																														
5	441.63																														
T5	<table border="1"> <thead> <tr> <th>Years</th> <th>Value (\$)</th> </tr> </thead> <tbody> <tr><td>0</td><td>400.00</td></tr> <tr><td>1</td><td>432.00</td></tr> <tr><td>2</td><td>464.00</td></tr> <tr><td>3</td><td></td></tr> <tr><td>4</td><td>528.00</td></tr> <tr><td>5</td><td>560.00</td></tr> </tbody> </table>	Years	Value (\$)	0	400.00	1	432.00	2	464.00	3		4	528.00	5	560.00	T6	<table border="1"> <thead> <tr> <th>Years</th> <th>Value (\$)</th> </tr> </thead> <tbody> <tr><td>0</td><td>400.00</td></tr> <tr><td>1</td><td>464.00</td></tr> <tr><td>2</td><td></td></tr> <tr><td>3</td><td>592.00</td></tr> <tr><td>4</td><td>656.00</td></tr> <tr><td>5</td><td>720.00</td></tr> </tbody> </table>	Years	Value (\$)	0	400.00	1	464.00	2		3	592.00	4	656.00	5	720.00
Years	Value (\$)																														
0	400.00																														
1	432.00																														
2	464.00																														
3																															
4	528.00																														
5	560.00																														
Years	Value (\$)																														
0	400.00																														
1	464.00																														
2																															
3	592.00																														
4	656.00																														
5	720.00																														

Card Set: Statements

S1 These two investments will take the same time to double your money.	S2 This investment will double your money in 12 years 6 months.
S3 This investment gives the worst return for your money over two years or more.	S4 This investment is the best one over 10 years.
S5 This investment is the best one over 20 years.	

Odd One Out?

Investment 1
\$100
Simple Interest Rate: 5%

Investment 2
\$400
Simple Interest Rate: 5%

Investment 3
\$200
Simple Interest Rate: 10%

Odd One Out?

Investment 1

$$A = 500 \times 1.06^4$$

Investment 2

$$A = 250 \times 1.06^2$$

Investment 3

$$A = 500 \times 1.03^2$$

Double Your Money

Investment 1

$$A = 500 \times 1.06^n$$

Investment 2

$$A = 250 \times 1.06^n$$

Investment 3

$$A = 500 \times 1.03^n$$

Which two investments will take exactly the same time to double the money?

Double Your Money

Investment 1

$$A = 500 + 20n$$

Investment 2

$$A = 200 + 8n$$

Investment 3

$$A = 200 + 20n$$

Which two investments will take exactly the same time to double the money?

Mathematics Assessment Project
CLASSROOM CHALLENGES

This lesson was designed and developed by the
Shell Center Team
at the
University of Nottingham
Malcolm Swan, Nichola Clarke, Clare Dawson, Sheila Evans
with
Hugh Burkhardt, Rita Crust, Andy Noyes, and Daniel Pead

It was refined on the basis of reports from teams of observers led by
David Foster, Mary Bouck, and Diane Schaefer
based on their observation of trials in US classrooms
along with comments from teachers and other users.

This project was conceived and directed for
MARS: Mathematics Assessment Resource Service
by
Alan Schoenfeld, Hugh Burkhardt, Daniel Pead, and Malcolm Swan
and based at the University of California, Berkeley

We are grateful to the many teachers, in the UK and the US, who trialed earlier versions
of these materials in their classrooms, to their students, and to
Judith Mills, Carol Hill, and Alvaro Villanueva who contributed to the design.

This development would not have been possible without the support of
Bill & Melinda Gates Foundation
We are particularly grateful to
Carina Wong, Melissa Chabran, and Jamie McKee

© 2012 MARS, Shell Center, University of Nottingham
This material may be reproduced and distributed, without modification, for non-commercial purposes,
under the Creative Commons License detailed at <http://creativecommons.org/licenses/by-nc-nd/3.0/>
All other rights reserved.
Please contact map.info@mathshell.org if this license does not meet your needs.

Exponential Functions

Lesson 5 of 6

Monthly Savings

Description:

Students extend the structure of exponential growth as it relates to compound interest and begin to look at monthly additions to an account to reach savings goals (as opposed to a static interest earning situation of a one time pay-in account). The real world application of retirement savings is addressed.

Georgia Standards of Excellence Addressed:

- MGSE9-12.A.SSE.3: Choose and produce an equivalent form of an expression to reveal and explain properties of the quantity represented by the expression.
- MGSE9-12.A.CED.4: Rearrange formulas to highlight a quantity of interest using the same reasoning as in solving equations. Examples: Rearrange Ohm's law $V = IR$ to highlight resistance R ; Rearrange area of a circle formula $A = \pi r^2$ to highlight the radius.
- MGSE9-12.F.IF.8b: Use the properties of exponents to interpret expressions for exponential functions. For example, identify percent rate of change in functions such as $y = (1.02)^t$, $y = (0.97)^t$, $y = (1.01)^{(12t)}$, $y = (1.2)^{(t/10)}$ and classify them as representing exponential growth and decay.
- MGSE9-12.F.BF.1a: Determine an explicit expression and recursive process (steps for calculation) from context. For example, if Jimmy starts out with \$15 and earns \$2 a day, the explicit expression " $2x + 15$ " can be described recursively (either in writing or verbally) as "to find out how much money Jimmy will have tomorrow, you add \$2 to his total today." $J_n = J_{n-1} + 2$, $J_0 = 15$.
- MGSE9-12.F.BF.2: Write arithmetic and geometric sequences recursively and explicitly, use them to model situations, and translate between the two forms. Connect arithmetic sequences to linear functions and geometric sequences to exponential functions.
- MGSE9-12.F.LE.2: Construct linear and exponential functions, including arithmetic and geometric sequences, given a graph, a description of a relationship, or two input-output pairs (include reading these from a table).
- MGSE9-12.F.LE.5: Interpret the parameters in a linear ($f(x) = mx + b$) and exponential ($f(x) = a \cdot d^x$) function in terms of context. (In the functions above, "m" and "b" are the parameters of the linear function, and "a" and "d" are the parameters of the exponential function.) In context, students should describe what these parameters mean in terms of change and starting value.

Standard(s) for Mathematical Practice Emphasized:

- SMP 1: Make sense of problems and persevere in solving them.
- SMP 5: Use appropriate tools strategically.
- SMP 8: Look for and express regularity in repeated reasoning.

Sequence of
Instruction

Activities Checklist

Engage

Recall the example from earlier in the unit (Lesson 3). Parents of a newborn baby want to save money so they have \$150,000 in 18 years to pay for a college education for the child. We saw if they invest their money in a savings account that offered a 6% annual percentage rate (APR) that is compounded monthly, they would need to deposit about \$51,000 today in one lump sum. Rather than establishing “lump sum” savings accounts, most people set up accounts where they make fixed monthly payments over a set number of years (say 18) in order to have reached a goal in the future (\$150,000 in 18 years). With your group members, estimate how much money this couple should deposit monthly for the next 18 years, in order to have \$150,000 in 18 years? Assume the interest rate stays the same at 6%.

Have students make educated guesses for the monthly payment needed and share results. After groups have shared lead the class in a discussion about this tedious process. Frame today’s lesson as a mathematical approach to find an answer efficiently.

Explore



You can take a guess that a group proposed OR you can use \$500. The following uses \$500 as an example:

INCLUDED IN THE STUDENT MANUAL

Task #15: Monthly Deposits

If the family deposits \$500 each month into this account (6% APR compounded monthly), how much money will they have in the account—

- one month later?
- two months later?
- six months later?
- 18 years later?

Divide students into groups of three to work on questions a, b, and c above and create a poster of values. Students should use technology appropriately and strategically to attain answers to the problems above. Spreadsheet capability, while not necessary, would be helpful. (More explanation of solutions provided in the explanation section of the lesson.)

Possible Solutions:

$$S_1 = \$500$$

$$S_2 = \$1002.50$$

$$S_3 = \$1507.51$$

$$S_7 = \$3552.94$$

$$S_{216} = \$193,676.60$$

$$S_{217} = \$195,144.98$$

Possible Misconception: Students may want to fall back to the default formula $FV = PV(1 + r/n)^{nt}$; however this formula assume t is measured in years. We are working with months. If you see groups heading in the wrong direction because of this, ask students to clarify the unit of time through the use of questioning strategies.

Explanation



Use the following questions to facilitate a classroom discussion:

- How did you arrive at your estimated monthly payments? Discuss your method/strategy used.
- Do you see any regularity in the work shown that could be used to predict the account value in 18 years?
- Using the method you used, could you find the amount to contribute over 18 years efficiently and quickly?
- One student reasoned as follows:

If the initial deposit is 500, I'm going to let $B_1 = 500$.

Then B_2 , or the balance one month later once two deposits have been made is

$$B_2 = 500 + 500(1.005) = \$1,002.50.$$

Furthermore, B_3 , the balance two months later, after three deposits have been made is

$$B_3 = 500 + 500(1.005) + 500(1.005)^2 = \$1,507.51$$

But the rest of her work was lost, except for this:

$$B_7 = 500 + 500(1.005) + 500(1.005)^2 + \dots + 500(1.005)^6.$$

What does B_7 represent?

- How did this student use repeated reasoning to record the amount in the account for different months?
- What about this process would be tedious and time consuming to calculate for 18 years?

In a brief teacher-lead conversation, share with students the concept of the **sum of a finite geometric series** as a way to express regularity in repeated reasoning (rather than calculating the B_{216} term.) Information follows and should be shared with the class in an open dialogue.

- First define a geometric series. Namely, a finite geometric series is a sum of the form.

$$S_n = P + Pa + Pa^2 + \dots + Pa^{(n-1)}$$

- In our example we have $P = 500$, $n = 7$ and $a = 1.005$ with P corresponding to the fixed monthly payment, n is the number of deposits that have been made, and $a = 1 + r$ is the monthly growth factor.
- If we multiply S_n by a , we have $aS_n = Pa + Pa^2 + Pa^3 + \dots + Pa^n$.
Then if we compute the difference

$$S_n - aS_n = (P + Pa + Pa^2 + \dots + Pa^{(n-1)}) - (Pa + Pa^2 + Pa^3 + \dots + Pa^n) = P - Pa^n$$

We can factor S_n out from the left side of the equation and find the general formula for the sum of a finite geometric series,

$$S_n = (P - Pa^n)/(1-a) = P((1 - a^n)/(1 - a)).$$

- Be sure to emphasize how useful this formula is in finance, as they will need to apply this in the future when determining a reasonable budget. By applying this formula to our example, we see

$$B_7 = 500 + 500(1.005) + 500(1.005)^2 + \dots + 500(1.005)^6 = 500(1-1.005^7)/(1-1.005) = \$3,552.94,$$

which matches what students found the long way on their calculator.

- Finally, applying the general formula to see what the account balance would be after making our last deposit 18 years in the future, we have,

$$P = 500, n = 18 \cdot 12 = 216, \text{ and } a = 1.005.$$

$$\text{Therefore, } S_{216} = 500 \cdot [(1-1.005^{216})/(1-1.005)] = \$193,676.60.$$

So, \$500 per month would be enough.

In groups, have students now work on the following task:

What is the minimum amount we need to deposit each month in order to have \$150,000 in 18 years?

Possible Solution:

We need to solve for the payment “P” in the general formula when $S_{216} = 150000$:

$$150000 = P \cdot [(1 - 1.005^{216}) / (1 - 1.005)] \text{ or } P = 150000 / [(1 - 1.005^{216}) / (1 - 1.005)]$$

They would need to make monthly payments of at least \$387.25 each month for 18 years in order to have \$150,000 dollars 18 years from now.

Commentary for the Teacher:

If you make a total of k deposits of P dollars every month into a bank account that accrues interest with an annual percentage rate (APR) of r (with growth factor each period of $a = 1 + r/12$) which is compounded monthly, then the total balance in the account at the time of the kth deposit is a geometric series.

$$S_k = P + Pa + Pa^2 + \dots + Pa^{k-1} = P \left(\frac{1-a^k}{1-a} \right)$$

Students may ask (or you may want to comment) that sometimes the compounding period is not every month. Sometimes interest is accrued each quarter, each week, twice a year, etc. In general, when an account has an APR of r with compounding n times per year, the growth factor each period, still denoted a, is $a = 1 + r/n$. In the case of monthly compounding above, $n = 12$.

P = Monthly deposit (same each month)

r = annual percentage rate (APR)

n = number of times the interest is accrued each year.

$a = 1 + r/n$ is the growth factor each period (typically each month)

k = Number of deposits made into the account

S_k = the balance in the account at the time of the kth deposit.

Practice Together in Small Groups/Individually

Have students work alone or in small groups on the Retirement Planning task, depending on the dynamic. For question two, ask students to select a career and a corresponding annual salary. (The possible solutions use an estimated annual salary of \$48,000.)

INCLUDED IN THE STUDENT MANUAL

Task #16: Retirement Planning

- If you want to save \$750,000 for your retirement, you invest your money in a savings account that has an APR of 5% which is compounded each month. You are 20 years old and planning to retire at age 65, how much money do you need to deposit into the savings account each month in order to reach your retirement goal at age 65?
- You are hired as a _____ (pick your career) and are offered an annual salary of _____ (research the average salary of your chosen career). You plan to contribute 2% of your paycheck each month to into a retirement account that with an APR of 7% compounded each month.
 - What is your monthly paycheck before taxes (contributions to retirement funds are typically taken out of the paycheck before taxes)?
 - How much money will have been saved if you work for 40 years at this job?
 - How much would you need to contribute each month in order to have \$500,000 when you retire?
 - Now assume that more realistically you are offered a raise of 2.5% each year. If you contribute 2% of your paycheck each month, how much will you have saved at the time of your retirement in 40 years?

Possible Solutions:

- We want a final balance of \$750,000. We know:

$$r = 0.05$$

$$n = 12$$

$$a = 1 + \frac{0.05}{12} = 1.00417$$

$$k = 12 \times 45 = 540 \text{ deposits (12 each year for 45 years)}$$

$$P = ?$$

$$750,000 = P \left(\frac{1 - (1.00417)^{540}}{1 - 1.00417} \right) \text{ so } P = \frac{750,000}{\frac{1 - (1.00417)^{540}}{1 - 1.00417}} = \$369.66$$

- $\frac{48000}{12} = \$4,000$

- Each month you contribute $4,000 \times 0.02 = \$80$; thus $P = 80$. We know $r = .07$, so $a = 1 + \frac{.07}{12} = 1.00583$ (this is the monthly growth factor). In 40 years, you will have made $40 \times 12 = 480$ deposits.

$$\begin{aligned} \text{Balance} &= S_{480} = 80 + 80(1.00583) + 80(1.00583)^2 + \dots + 80(1.00583)^{480-1} \\ &= 80 \left(\frac{1 - (1.00583)^{480}}{1 - 1.00583} \right) \\ &= \$290,749.37 \end{aligned}$$

Exponential Functions

Lesson 6 of 6

Comparing Payment Options

Description:

In this final lesson, students will look at different payment options for purchasing a car. They will be looking at the amount of interest charged monthly and how that interest accumulates over the course of the loan.

Georgia Standards of Excellence Addressed:

- MGSE9-12.A.SSE.3: Choose and produce an equivalent form of an expression to reveal and explain properties of the quantity represented by the expression.
- MGSE9-12.A.CED.4: Rearrange formulas to highlight a quantity of interest using the same reasoning as in solving equations. Examples: Rearrange Ohm's law $V = IR$ to highlight resistance R ; Rearrange area of a circle formula $A = \pi r^2$ to highlight the radius.
- MGSE9-12.F.IF.8b: Use the properties of exponents to interpret expressions for exponential functions. For example, identify percent rate of change in functions such as $y = (1.02)^t$, $y = (0.97)^t$, $y = (1.01)^{(12t)}$, $y = (1.2)^{(t/10)}$ and classify them as representing exponential growth and decay.
- MGSE9-12.F.BF.1a: Determine an explicit expression and recursive process (steps for calculation) from context. For example, if Jimmy starts out with \$15 and earns \$2 a day, the explicit expression " $2x + 15$ " can be described recursively (either in writing or verbally) as "to find out how much money Jimmy will have tomorrow, you add \$2 to his total today." $J_n = J_{n-1} + 2$, $J_0 = 15$.
- MGSE9-12.F.BF.2: Write arithmetic and geometric sequences recursively and explicitly, use them to model situations, and translate between the two forms. Connect arithmetic sequences to linear functions and geometric sequences to exponential functions.
- MGSE9-12.F.LE.2: Construct linear and exponential functions, including arithmetic and geometric sequences, given a graph, a description of a relationship, or two input-output pairs (include reading these from a table).
- MGSE9-12.F.LE.5: Interpret the parameters in a linear ($f(x) = mx + b$) and exponential ($f(x) = a \cdot d^x$) function in terms of context. (In the functions above, "m" and "b" are the parameters of the linear function, and "a" and "d" are the parameters of the exponential function.) In context, students should describe what these parameters mean in terms of change and starting value.F.9: Determine an explicit expression, a recursive process, or steps for calculation from a context.

Standard(s) for Mathematical Practice Emphasized:

- SMP 4: Model with mathematics.
- SMP 8: Look for and express regularity in repeated reasoning.

Sequence of Instruction

Activities Checklist

Engage

Ask the students the following questions:

1. If I finance a \$24,000 car for five years (or 60 months), will the car be paid off after five years if I only pay \$400 a month? Why or why not?
2. What are some factors that you think influence the amount of a car payment?

Using the car they selected on the first day of this unit, students should guess the amount of the monthly payment necessary in order to pay off their car in five years. Now, our job is to figure out the actual payment amount.

Students should assume they are charged interest at an APR of 8% which is compounded each month. Take one of the student's guesses for how much they will have to pay each month. Here we'll use \$500 for a \$60,000 vehicle. Have a volunteer come to the board to set up a table similar to the one below. Note that the APR is 8%, this means the interest rate each month is $\frac{0.08}{12} = 0.00667$.

Month (t)	Starting Balance	Interest Charged	Payment	End Balance
0 (Jan)	0	0	0	\$60,000
1 (Feb)	\$60,000	$60,000(0.00667) = \$400$	\$500	\$59,900
2	\$59,900	$59,900(0.00667) = \$399.33$	\$500	\$59,799.33
...				...
11 (Dec)				

As a class, complete the first two rows (or more if needed) so students understand how to use and read the table. Notice from the table, we will assume you paid zero money down at the time of the purchase, so nothing was paid in January when the car was bought.

Explore



Based on the scenario above, ask students to complete the table and use it to answer the following questions:

- a. What is the remaining balance after the first year? After completing several rows in your table, try to identify a pattern in order to derive a general formula.
- b. What is the total amount of interest paid in the first year?
- c. How much of your payments in the first year went to pay off the car? How much went towards interest?
- d. If you pay \$500 a month for 60 months (with the first month free, thus 59 payments), will the car be paid off?
- e. Find the minimum payment needed each month in order to for the car to be fully paid in 60 months (again assuming there is no payment in the first month $t=0$).

Explanation



Month (t)	Starting Balance	Interest Charged	Payment	End Balance
0 (Jan)	0	0	0	\$60,000
1 (Feb)	\$60,000	$60,000(0.00667) = \$400$	\$500	\$59,900
2	\$59,900	$59,900(0.00667) = \$399.33$	\$500	\$59,799.33
3	\$59,799.33	\$398.86	\$500	\$59,698.19
4				
5				
6				
7				
8				
9				
10				
11 (Dec)				

It is very cumbersome to go month by month, once students pick up on the repeated calculation, encourage them to try to generalize the situation to save time. Again, students are creating an equation to model the situation. Below we generalize the calculations to find a general formula where r denotes the APR rate and n is the number of times compounded in a year. As in the past, we let $a = (1 + \frac{r}{n})$ denote the monthly growth factor, B_0 denotes the initial value of the car, and P denotes the fixed monthly payments.

Month (t)	Starting Balance	Interest Charged	Payment	End Balance
0 (Jan)	0	0	0	B_0
1 (Feb)	B_0	$B_0(r/n)$	P	$B_0 + B_0(r/n) - P = B_0(1 + r/n) - P = B_0 \times a - P$
2	$B_0 \times a - P$	$(B_0 \times a - P) \frac{r}{n}$	P	$(B_0 \times a - P) + (B_0 \times a - P)(r/12) - P = (B_0 \times a - P)(1 + r/12) - P = (B_0 \times a - P) \times a - P = B_0 \times a^2 - (P + P \times a)$
3				$B_0 \times a^3 - (P + P \times a + P \times a^2)$
4				
5				
6				
7				
8				
9				
10				
11 (Dec)				$B_0 \times a^{11} - (P + P \times a + \dots + P \times a^{11} - 1)$

The expression written in orange above is the key step in the process. A lot of regrouping and reordering is involved, so be sure to go slowly through the process so students see where the general formula comes from, and appreciate how much time it saves.

Let $B(t)$ denote the end balance t months after purchasing the car. We see from the table above that we have a general formula for $B(t)$.

$$\begin{aligned} B(t) &= B_0 \times a^t - (P + P \times a + \dots + P \times a^{t-1}) \\ &= 60,000(1.00667)^t - (500 + 500(1.00667) + \dots + 500(1.00667)^{t-1}) \end{aligned}$$

Hopefully a group notices the payments represent a geometric series, and we can rewrite the sum as follows:

$$\begin{aligned} S_t &= 500 + 500(1.00667) + \dots + 500(1.00667)^{t-1} \\ &= 500 \left(\frac{1-1.00667^t}{1-1.00667} \right) \\ &= P \left(\frac{1-a^t}{1-a} \right) \end{aligned}$$

And so we have:

$$B(t) = B_0 a^t - P \left(\frac{1-a^t}{1-a} \right) = 60,000(1.00667)^t - 500 \left(\frac{1-(1.00667)^t}{1-1.00667} \right)$$

When $t=11$, we have:

$$B(11) = 60,000(1.00667)^{11} - 500 \left(\frac{1-(1.00667)^{11}}{1-1.00667} \right) = \$58,864.85$$

Compare the output of the general with the values students obtained in their tables for different values of t to be sure the formula is consistent with the table. There will probably be some minor differences in the values in the table compared to the output from the formula. This is due to rounding differences.

After one year, we have made $11 \times 500 = \$5,500$ in payments.

Of the 5,500 you paid, $60,000 - 58,864.85 = \$1,135.15$ towards the actual value of the car.

The remaining \$4,364.85 paid off interest.

The balance at the end of the five years will be $B(59) = \$52,813.98$.

To find the minimum monthly payment needed, we set $B(59) = 0$ in the following equation.

$$B(59) = 60,000(1.00667)^{59} - P \left(\frac{1-(1.00667)^{59}}{1-1.00667} \right) = 0$$

Solving for P :

$$P = 60,000(1.00667)^{59} \left(\frac{1-(1.00667)}{1-(1.00667)^{59}} \right) = \$1,233.48$$

Now ask the students to look at the structure of the general formula for $B(t)$.

- What does the $60,000(1.00667)^t$ represent practical terms?
- What does the $P \left(\frac{1-1.00667^t}{1-1.00667} \right)$ represent in practical terms?

$60,000(1.00667)^t$ is the future value of the car t months after it has been purchased.

$P \left(\frac{1-1.00667^t}{1-1.00667} \right)$ is the future value of your payments t months after the car has been purchased.

Therefore we see from the equation,

$$B(59) = 60,000(1.00667)^{59} - P \left(\frac{1-(1.00667)^{59}}{1-1.00667} \right) = 0$$

that the car is paid off when the future value of the car and the future value of the payments are equal.

Practice Together in Small Groups/Individually

Ask students to work in small groups on the Car Purchase Options task. They will again use the car they chose in the opening lesson of this unit to compare different options for purchasing the car.

INCLUDED IN THE STUDENT MANUAL

Task #17: Car Purchase Options

You have three options to buy your new car (assume all of which have a 6% annual percentage rate that is being compounded monthly):

- A. Pay the entire cost of the car on the day of purchase.
- B. Payoff the car in 71 equal payments over 72 months (no money down).
- C. Make a down payment of 20% at the time of purchase. Then payoff the remaining value in 71 equal payments over **72 months**.

Evaluate Understanding

Have students compare answers with other students, and answer any questions that arise. Take this time to really listen to students as they compare answers to check for understanding. Discuss differences in the plans for purchasing the car using students' own work.

Closing Activity

Students should write a journal entry for the following:

Summarize your findings for the Car Purchase Options task. You may choose to make a pro/con list to compare. Most importantly, make sure you provide a clear and concise argument for the option you feel is best.

Independent Practice:

Assign students the following problems.

1. A car dealer offers you a choice of 0% financing for 60 months or \$2500 cash back on a new vehicle. You have a pre-approved 60-month loan you can use from your credit union at a 4% interest rate. If the monthly payments at 0% are \$16.67 per \$1000 financed, and the monthly payments at 4% are \$18.41 per \$1000 financed, what is the range of new car prices for which the cash back option will cost you less? For what range of car prices should you take the 0% financing?
2. A car dealer offers you two deals on a car that costs \$16,000.00. Please calculate the monthly payment, given these two payment options the car dealer is offering.
Payment Option 1: You can finance the car for 60 months with no interest if you make a \$3,000.00 down payment.
Payment Option 2: You can finance the car for 72 months (6 years) with no down payment.
Which monthly payment amount is lower?
3. The cash price for Roger's new car was \$9,428. The dealer required a 20% down payment and the rest was financed. Roger agreed to repay the loan in 36 payments. The monthly payments included the finance charge and came to \$231.18. What was the total cost of the car?

SREB Readiness Courses
Transitioning to college and careers

College Readiness Mathematics

Unit 7 . Exponential Functions
Student Manual
Version 3

Name



Unit 7 . Exponential Functions

Table of Contents

Lesson 1.....	3
Lesson 2.....	7
Lesson 3.....	14
Lesson 5.....	18
Lesson 6.....	20

Task #2: Linear or Exponential?

1. In (a)–(e), say whether the quantity is changing in a linear or exponential fashion.

a. A savings account, which earns no interest, receives a deposit of \$723 per month.

b. The value of a machine depreciates by 17% per year.

c. Every week, $\frac{9}{10}$ of a radioactive substance remains from the beginning of the week.

d. A liter of water evaporates from a swimming pool every day.

e. Every 124 minutes, $\frac{1}{2}$ of a drug dosage remains in the body.

(Source: Illustrative Mathematics)

2. The functions below represent exponential growth or decay. What is the initial quantity? What is the growth rate? Is this growth or decay and how do you know? Make a rough sketch of the graph of the function and write a story problem to go with each equation.

a. $P=8(1.23)^t$

b. $Q=3.1(0.78)^t$

c. $y=3^{t/2}$

d. $w = \left(\frac{3}{2}\right)^t$

e. $P=10(3)^{t/2}$

Task #4: Ponzi Pyramid Schemes

Max has received this email. It describes a scheme for making money.

From: A Crook

Date: Thursday 15th January 2009

To: B Careful

Subject: Get rich quick!

Dear friend,

Do you want to get rich quick? Just follow the instructions carefully below and you may never need to work again:

1. At the bottom of this email there are 8 names and addresses.
Send \$5 to the name at the top of this list.
2. Delete that name and add your own name and address at the bottom of the list.
3. Send this email to 5 new friends.

If that process goes as planned, how much money would be sent to Max? Show your calculations.

“Ponzi” Pyramid Schemes: (continued)

2. What could possibly go wrong? Explain your answer clearly.

3. Why do they make Ponzi schemes like this illegal?

Task #5: Snail Invasion

In 1966, a Miami boy smuggled three Giant African Land Snails into the country. His grandmother eventually released them into the garden, and in seven years there were approximately 18,000 of them. The snails are very destructive and had to be eradicated. According to the USDA, it took 10 years and cost \$1 million to eradicate them.

- a. Assuming the snail population, $P(t)$, grows exponentially, write an expression for it in terms of the number, t , of years since their release.

- b. By what percent did snail population grow each year?

- c. By what percent did the snail population grow each month?

- d. Using a calculator or technology, determine how long does it take for the population to double?

- e. *(Optional for additional challenge) Assuming the cost of eradicating the snails is proportional to the population, how much would it have cost to eradicate them if*
 - i. *They had started the eradication program a year earlier?*

 - ii. *They had let the population grow unchecked for another year?*

(Source: Illustrative Mathematics)

Task #6: Facebook Users

The number of Facebook users worldwide reached one billion on October 4, 2012. Behind India and China, Facebook would be the third largest country in the world (larger than the US!) On April 24, 2012 there were 800 million Facebook users worldwide. Find a formula for the total number of Facebook users, N (in billions of users), t days after Jan 1, 2012. This means January 1 is $t = 0$, January 2 is $t = 1$, ..., and December 31 is $t=365$. (Note 2012 was a leap year which is why December 31 is $t = 365$. In a non-leap year December 31 is $t = 364$).

Task #7: Forms of Exponential Expressions

Four physicists describe the amount of a radioactive substance, Q in grams, left after t years:

- $Q = 300e^{-0.0577t}$

- $Q = 300\left(\frac{1}{2}\right)^{t/12}$

- $Q = 300 \times 0.9439^t$

- $Q = 252.290 \times (0.9439)^{t-3}$

- a. Show that the expressions describing the radioactive substance are all equivalent (using appropriate rounding).

- b. What aspect of the decay of the substance does each of the formulas highlight

(<http://www.illustrativemathematics.org/illustrations/1305>)

(Source: Illustrative Mathematics)

Task #8: Exponential Functions

The figure to the right shows the graphs of the exponential functions $f(x) = c \cdot 3^x$ and $g(x) = d \cdot 2^x$, for some numbers $c > 0$ and $d > 0$. They intersect at the point (p, q) .

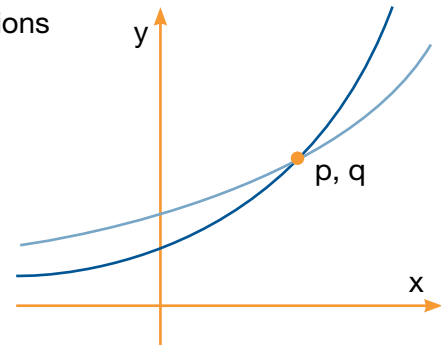

a. Which is greater, c or d ? Explain how you know.

b. Imagine you place the tip of your pencil at (p, q) and trace the graph of g out to the point with x -coordinate $p + 2$. Imagine I do the same on the graph of f . What will be the ratio of the y -coordinate of my ending point to the y -coordinate of yours?

(Source: Illustrative Mathematics)

Task #10: Buying a Car

You wish to purchase a certain car. Two dealerships in town are selling the car for \$20,000. Both dealerships are unique in unusual finance offers. Rather than monthly payments, you are charged interest over time, yet you are expected to pay the car off (plus interest) in one lump sum payment at a date of your choosing. The dealerships don't want to deal with paper work and are really only interested in "loaning" you money with interest. However, each offers a different payment plan. You have discretion of when you want to pay off this car.

- A. No down payment needed or payments in the first year. When you do pay for the car, you will make one full payment for the car plus any interest accrued. This plan comes with a 12% interest/per year charge.
- B. No down payment needed. No fees or penalties for not making payments. Again, you will make one full payment for the car plus any interest accrued. This plan charges 1% interest per month.

As a group, decide what plan is better for your unique needs. Your presentation to your peers should include details about how much you will have to pay off at different times and how your group arrived at the decisions you made.

Task #11: Part 1: Saving for College

When you invest money in a bank account (and add interest to your balance), the same terminology and notation applies. For example, imagine parents of a newborn baby want to invest money today in order to pay for the child's college 18 years from now. They have \$10,000 of savings they wish to deposit all at once into one savings account, which they will withdraw from 18 years from now.

- A. Bank A advertises an APR of 6% with monthly compounding. (Think about how much of this interest is applied monthly.)
- B. Bank B advertises an EAR of 6%. This means 6% interest is accrued once each year.

Which bank has the better savings account? Create a model that shows what plan the parents should choose in order to save the maximum amount possible for college.

Part 2: Saving for College with the End in Mind

Imagine the parents wish to have \$150,000 in account A in 18 years, how much would they need to deposit today?

Task #12: Buying on Credit

If you charge \$500 on a credit card today, how much will the balance be in two years (assuming no additional fees) if the credit card has a 10% APR that is compounded—

- a. once a year?

- b. once a month?

- c. once a week?

If you need \$25,000 eight years from now, what is the minimum amount of money you need to deposit into a bank account that pays an annual percentage rate (APR) of 5% that is compounded—

- a. once a year?

- b. once a month?

- c. once a day?

Task #15: Monthly Deposits

If the family deposits \$500 each month into this account (6% APR compounded monthly), how much money will they have in the account—

a. one month later?

b. two months later?

c. six months later?

d. 18 years later?

Task #17: Car Purchase Options

You have three options to buy your new car (assume all of which have a 6% annual percentage rate that is being compounded monthly):

- A. Pay the entire cost of the car on the day of purchase.
- B. Payoff the car in 71 equal payments over 72 months (no money down).
- C. Make a down payment of 20% at the time of purchase. Then payoff the remaining value in 71 equal payments over **72 months**.

SREB

SREB Readiness Courses
Transitioning to college and careers

College Readiness Mathematics

Unit 8 . Summarizing and
Interpreting Statistical Data
Version 3

Southern
Regional
Education
Board

592 Tenth Street, NW
Atlanta, GA 30318
(404) 875-9211

www.sreb.org

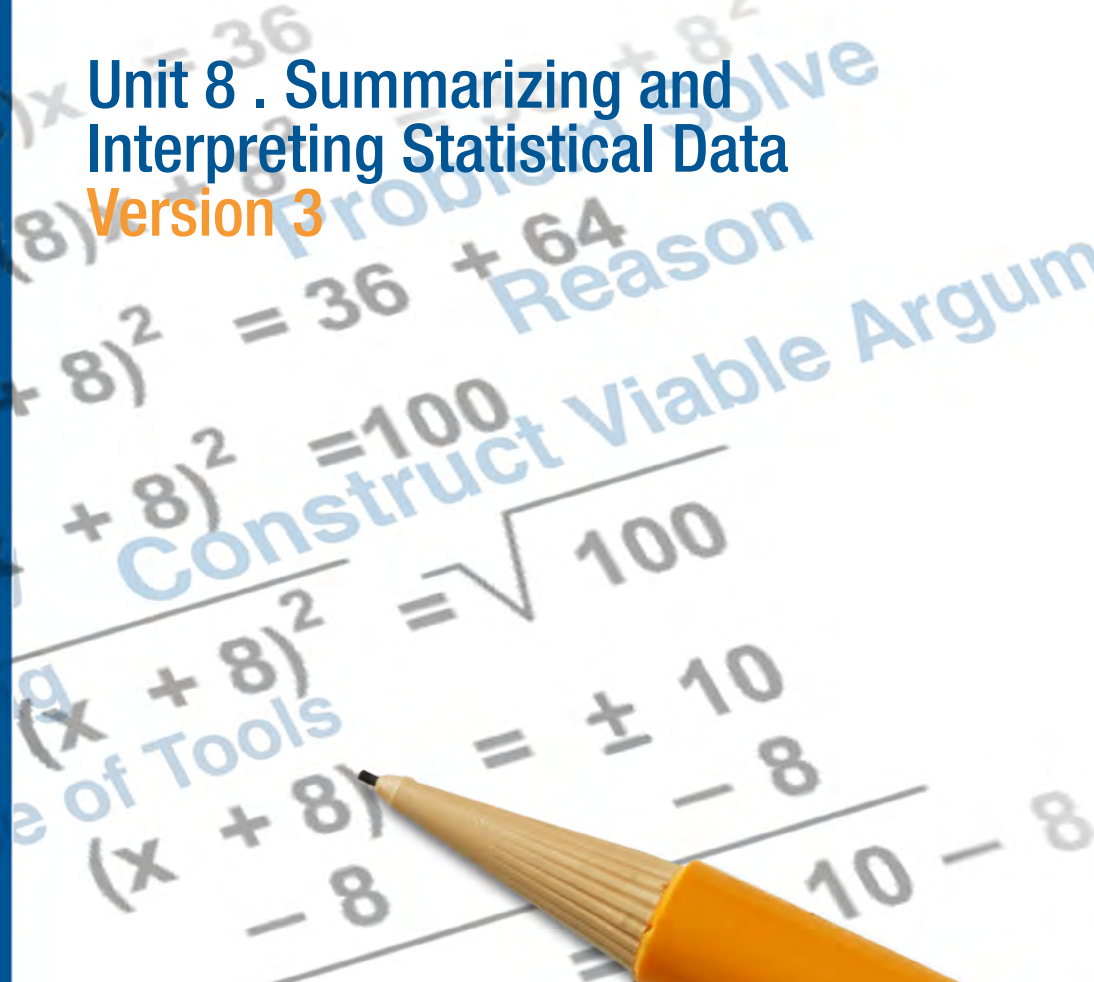

Unit 8 . Summarizing and Interpreting Statistical Data

Overview

Purpose

In this unit students will further develop skills to read, analyze, and communicate (using words, tables, and graphs) relationships and patterns found in data sets of one or more variables. Learning how to choose the appropriate statistical tools and measurements to assist in the analysis, being able to clearly communicate your results either in words, graphs, or tables, and being able to read and interpret graphs, measurements, and formulas are crucial skills to have in a world overflowing with data. Students explore these concepts while modeling real contexts based on data they collected.

This unit is an optional unit. Districts, schools or teachers have the option to teach this unit to all or any group of students. Should your state have an emphasis on statistics in postsecondary institutions, or if students plan to major in a field with a statistical emphasis, this unit may be of particular interest.

Essential Questions:

How can you determine whether a variable is quantitative or categorical and why is it important to make this distinction when collecting and summarizing data?

Why is it important to detect bias in surveys and experiments and how can you improve the design of studies to avoid bias?

What tool (two-way table, pie chart, histogram, scatterplot) is appropriate to use when analyzing your data?

How can you identify and Interpret differences in shape, center and spread in the context of the data sets?

How can you determine the strength of an association between two quantitative variables from a scatterplot or in terms of the context of the data sets?

Why would you want to find the regression line to model the relationship between two quantitative variables and how can you interpret the meaning of the slope and intercept of the regression line in the context of the data set?

Georgia Standards of Excellence:

Interpreting Categorical and Quantitative Data

Summarize, represent and interpret data on a single count or measurement variable.

- MGSE9-12.S.ID.1: Represent data with plots on the real number line (dot plots, histograms, and box plots).
- MGSE9-12.S.ID.2: Use statistics appropriate to the shape of the data distribution to compare center (median, mean) and spread (interquartile range, mean absolute deviation, standard deviation) of two or more different data sets.
- MGSE9-12.S.ID.3: Interpret differences in shape, center, and spread in the context of the data sets, accounting for possible effects of extreme data points (outliers).

Summarize, represent and interpret data on two categorical and quantitative variables.

- MGSE9-12.S.ID.5: Summarize categorical data for two categories in two-way frequency tables. Interpret relative frequencies in the context of the data (including joint, marginal, and conditional relative frequencies). Recognize possible associations and trends in the data.
- MGSE9-12.S.ID.6: Represent data on two quantitative variables on a scatter plot, and describe how the variables are related.
- MGSE9-12.S.ID.6a: Decide which type of function is most appropriate by observing graphed data, charted data, or by analysis of context. Emphasize linear, quadratic and exponential models.
- MGSE9-12.S.ID.6c: Using given or collected bivariate data, fit a linear function for a scatter plot that suggests a linear association..

Interpret linear models.

- MGSE9-12.S.ID.7: Interpret the slope (rate of change) and the intercept (constant term) of a linear model in the context of the data.
- MGSE9-12.S.ID.8: Compute (using technology) and interpret the correlation coefficient “ r ” of a linear fit. (For instance, by looking at a scatterplot, students should be able to tell if the correlation coefficient is positive or negative and give a reasonable estimate of the “ r ” value.) After calculating the line of best fit using technology, students should be able to describe how strong the goodness of fit of the regression is, using “ r ”.
- MGSE9-12.S.ID.9: Distinguish between correlation and causation.

Making Inferences and Justifying Conclusions

Understand and evaluate random processes underlying statistical experiments.

- MGSE9-12.S.IC.1: Understand statistics as a process for making inferences about population parameters based on a random sample from that population.

Make inferences and justify conclusions from sample surveys, experiments and observational studies.

- MGSE9-12.S.IC.3: Recognize the purposes of and differences among sample surveys, experiments, and observational studies; explain how randomization relates to each.

Prior Scaffolding Knowledge / Skills:

Students should be able to create various data distributions including dot plots, histograms, and box plots.

Students should be able to describe and summarize the data distributions with attention given to the shape, center, and spread.

Students should be able to create a data distribution for a bivariate set of data (i.e. scatterplot).

Students should be able to use a scatterplot to describe and summarize the relationship between two variables.

Lesson Progression Overview:

Lesson Big Idea	Lesson Details	Georgia Standards of Excellence	Standards for Mathematical Practice
Lesson 1: The Language of Data	Students will review the terminology required to communicate and interpret interesting characteristics of datasets. This lesson also serves the purpose of collecting data from the students that can be used later in this unit.	None	SMP 3 SMP 6
Lesson 2: Sampling from a Population	Students attempt to derive their own, unbiased sampling strategies, and learn it is extremely difficult to avoid bias when sampling. Students then see the power behind randomly selecting samples from a population. Conclusions based upon poor sampling have little value when generalizing to a larger population.	MGSE9-12.S.IC.1	SMP 3 SMP 4 SMP 6
Lesson 3: Correlation and Causation	Students explore the distinction between correlation and causation. Students learn the difference between observational studies and randomized experiments, and how they can affect whether or not causality can be established.	MGSE9-12.S.ID.9 MGSE9-12.S.IC.1 MGSE9-12.S.IC.3	SMP 3 SMP 4 SMP 6
Lesson 4: Analyzing Relationships Between Two Categorical Variables	Using data collected from the student survey in lesson, students create a model using two-way tables as a tool to help determine whether there seems to be convincing evidence for correlation between two categorical variables. The distinction between correlation and causation is revisited, as is experiment design.	MGSE9-12.S.ID.5	SMP 1 SMP 2 SMP 3 SMP 4
Lesson 5: Formative Assessment Lesson: Representing Data Using Frequency Graphs	This lesson unit is intended to help you assess how well students: <ul style="list-style-type: none"> • Are able to use frequency graphs to identify a range of measures and make sense of this data in a real-world context. • Understand that a large number of data points allow a frequency graph to be approximated by a continuous distribution. 	MGSE9-12.S.ID.1 MGSE9-12.S.ID.2 MGSE9-12.S.ID.3	SMP 1 SMP 2 SMP 3
Lesson 6: The Shape of Quantitative Data	This lesson introduces a second measure of center, the mean. These two measurements do not sufficiently summarize the shape of your data, and this lesson builds a conceptual understanding of the standard deviation as a measurement for the spread of the values in your data.	MGSE9-12.S.ID.1 MGSE9-12.S.ID.2 MGSE9-12.S.ID.3	SMP 2 SMP 4 SMP 7
Lesson 7: Measuring the Strength of an Association	In this lesson students think about relationships between various pairs of quantitative variables taken from a large dataset on specifications of many different car models. First using intuition, followed by informally assessing trends in a scatterplot, and finally by describing the strength of an association using a correlation coefficient.	MGSE9-12.S.ID.6 MGSE9-12.S.ID.8	SMP 2 SMP 3 SMP 4 SMP 5 SMP 6
Lesson 8: Interpreting the Line of Best Fit	Students further analyze the relationship between two quantitative variables using scatterplots. In this lesson, students informally fit their own line of best fit. After constructing a linear model depicting an association between two variables, students use the model to make predictions and interpret the meaning of the slope and the intercept of a linear model in the context of the data.	MGSE9-12.S.ID.6 MGSE9-12.S.ID.6a MGSE9-12.S.ID.6c MGSE9-12.S.ID.7	SMP 2 SMP 4

Summarizing and Interpreting Statistical Data

Lesson 1 of 8

The Language of Data

Description:

Students will review the terminology required to communicate and interpret key characteristics of datasets. This lesson also serves the purpose of collecting data from the students that can be used later in this unit.

Georgia Standards of Excellence Addressed:

- This lesson does not really focus on any particular content standards. Rather, it is an introduction to the unit and defines terms that will be used throughout. In addition, the unit serves to collect data from a class survey that can be used throughout the lesson.

Standard(s) for Mathematical Practice Emphasized:

- SMP 3: Construct viable arguments and critique the reasoning of others.
- SMP 6: Attend to precision.

Sequence of
Instruction

Activities Checklist

Engage

Entry Event: The statistics unit will require students to be able to collect, organize, display and analyze data. First step is collecting data. This unit will begin by having each student answer questions on a survey (see handout). The questions on the handout are fairly generic. Feel free to modify the survey as you (or your students wish) in order to make it more fun and relevant to the interests of your students or what might be going on in the news at the moment.

Later in the day, you may want to enlist some help entering the data you collected from your students into a spreadsheet using software such as Excel. You may have prior experience working with polling websites such as SurveyMonkey.com. Such websites can usually export results into a spreadsheet that you can edit.

INCLUDED IN THE STUDENT MANUAL

Summarizing and Interpreting Statistical Data

In-Class Survey

The purpose of this survey is to provide data for use during the semester. Individuals will not be identified. You may leave any answers blank.

1. Are you male or female?
2. What is your height in inches (e.g., 5'6" = 66 inches)? _____
3. Are you right or left-handed? _____
4. How many siblings do you have? _____
5. What is your birth order (1=oldest/only child, 2=second oldest, etc.)? _____
6. How many hours of exercise do you get in a typical week? _____
7. On average, how many hours of television do you watch per week? _____
8. Make up a very random four-digit number. _____
9. Which award would you rather win: Academy Award, Olympic Gold or Nobel Prize?
10. Record your pulse (beats/minute) after measuring it in class. _____
11. How many piercings (ear, nose, etc.) do you have (count each hole)? _____
12. About how many friends do you have on Facebook (zero if not on Facebook)? _____
13. How many text messages do you send in a typical day? _____
14. What is your preferred social network (Facebook, Twitter, Instagram, FourSquare, etc.)?

15. How do you commute to school? _____
16. Do you use a Mac or PC? _____
17. How many hours of sleep do you get on a typical night? _____

Explore



While students are filling out the survey, write the following definitions on the board (or project a slide):

We obtain information about **cases** in a dataset. For example, right now, each student is a case.

A **variable** is any characteristic that is recorded for each case.

A **categorical variable** divides cases into groups, placing each case into exactly one of two or more categories.

A **quantitative variable** measures or records a numerical quantity for each case.

Ask students, working in pairs or in threes, to identify whether each variable collected in the survey is a categorical or quantitative variable.

Explanation

Students might initially think cases are always individual people, so it is important to use examples of datasets where cases are not people, such as states, countries, movies, baseball teams. For example, the practice together example has movies for cases.

It is important to note that numerical operations, such as adding and averaging, make sense for quantitative variables, but do not make sense for categorical variables. It certainly is still possible to put a quantitative framework in place to analyze categorical data. For example, what **proportion** of students is right-handed? The class will delve into this framework over the next several lessons.

Lastly, explain that typically, when people work with datasets, information about each case is entered in a single row of the dataset, while the variables generally correspond to the columns.

Practice Together in Small Groups/Individually



On the next page is a sample data set of movies from 2011. This data is taken from the following public dataset:

<https://docs.google.com/spreadsheet/ccc?key=0AItk3Tn01ZsWdEJ1cHFjbmVyejhnN1JnQINyWW5lUkE&authkey=CPuZiLcG - gid=29>.

Certainly feel free to use your own dataset (or at least more current movies if desired). It is important to use a dataset where the cases are not individual people.

INCLUDED IN THE STUDENT MANUAL

Task #1: Movie Dataset

Film	Lead Studio	Audience score %	Genre	Number of Theatres in US Opening Weekend	Budget (millions of dollars)
Cars 2	Pixar	56	Animation	4115	200
Dolphin Tale	Independent	81	Drama	3507	37
Green Lantern	Warner Bros	48	Action	3816	200
Harry Potter and the Deathly Hallows Part 2	Warner Bros	92	Fantasy	4375	125
Mission Impossible 4	Paramount	86	Action	3448	145
Moneyball	Columbia	89	Drama	2993	50
50/50	Independent	93	Comedy	2458	8
Apollo 18	Weinstein Company	31	Horror	3328	5
Captain America: The First Avenger	Disney	75	Action	3715	140
Contagion	Warner Bros	63	Thriller	3222	60
The Muppets	Disney	87	Comedy	3440	45
X-Men: First Class	Disney	88	Action	3641	160
Zookeeper	Happy Madison Productions	42	Comedy	3482	80

Identify the cases in the dataset.

Identify all of the variables contained in the dataset, and determine whether each variable is quantitative or categorical.

Evaluate Understanding

Share answers (and questions) regarding the previous exercise of identifying cases and variables. Then, turn the discussion towards the identifying relationships between two different variables and explanatory and response variables.

What percentage of students uses a Mac?

What is the average number of Facebook friends of all students in our class?

These are questions about a single variable.

Often, the most interesting questions arise when analyzing the relationship between two different variables. For example, based on the questions for the student survey, we could ask the following questions:

- Are males or females more likely to use a Mac?
- Do people with more siblings sleep less?
- Do students who exercise more have lower pulse rates?
- Do PC users text more than Mac users?

When using one variable to help understand or predict the values of another variable, we call the former the **explanatory variable** and the latter the **response variable**.

For example, in the questions above:

Gender (categorical) is the explanatory variable. Computer operating system (categorical) is the response variable.

Number of siblings (quantitative) is the explanatory variable. Sleep hours (quantitative) is the response variable.

Exercise hours (quantitative) is explanatory. Pulse rate (quantitative) is the response variable.

Computer operating system (categorical) is the explanatory variable while the number of texts sent in a day (quantitative) is the response variable.

It is not the variables themselves that determine which is explanatory and which is response, rather it is the question that is being asked that determines the relationship. For example, we could also have asked, “are people who text more frequently more likely to use a PC or a Mac?”

Closing Activity



Think of two variables you are interested in determining whether or not some relationship exists between the two. State the question you would like to investigate. Now imagine you want to collect data in order to try to answer the question. What are the cases in your dataset? What two variables would you need to collect? Determine whether each variable is categorical or quantitative. Which is the explanatory variable? The response variable?

Independent Practice:

INCLUDED IN THE STUDENT MANUAL

Independent Practice Questions

1. For each situation described below, what are the cases? What is the variable? Is the variable quantitative or categorical?
 - a. People in a city are asked whether they support increasing the driving age to 18 years old.
 - b. Measure how many hours a fully charged laptop battery will last.
 - c. The value of tips a taxi driver receives for each trip.
 - d. Compare the poverty rates of each country in the world.
2. The manager reviews sales and wants to determine whether the amount of sales is associated to the weather outside. How the data is recorded determines whether the variables are quantitative or categorical. Describe how each variable could be measured quantitatively. Describe how each variable could be measured categorically.

Resources/Instructional Materials Needed:

- A student survey (you can customize a survey to the interests of your students).
- A dataset such as the 2011 movies data shown above.

Summarizing and Interpreting Statistical Data

Lesson 2 of 8

Sampling from a Population

Description:

Students attempt to derive their own, unbiased sampling strategies, and learn it is extremely difficult to avoid bias when sampling. Students then see the power behind randomly selecting samples from a population. Conclusions based upon poor sampling have little value when generalizing to a larger population.

Georgia Standards of Excellence Addressed:

- MGSE9-12.S.IC.1: Understand statistics as a process for making inferences about population parameters based on a random sample from that population.

Standard(s) for Mathematical Practice Emphasized:

- SMP 3: Construct viable arguments and critique the reasoning of others.
- SMP 4: Model with mathematics.
- SMP 6: Attend to precision.

Sequence of
Instruction

Activities Checklist

Engage



The opening activity is aimed to show students that humans are bad at sampling, no matter how hard we try to be unbiased. Thus, the best way to truly generate an unbiased sample from a population is to randomly select cases from the population. This activity uses the Star-Spangled Banner; you could modify the song choice to be a popular song or many other possibilities, but it is important to have your students try to do the unbiased sampling themselves.

Project (and read) the first two verses of the “Star-Spangled Banner” (there are four verses in total). Ask students to imagine they that they want to estimate the average length of all the words in the “Start-Spangled Banner.” Pass out the first page of the “Star-Spangled Banner” student handout. Tell each student (working alone) to pick a sample of 10 words that are representative of all words in the address. Note if your class size is less than 20 students, you may can ask each student to pick two different samples of 10 that are representative of the words in the song (so you can get a more robust dot plot). If students press you on what “representative” means, be vague, but explain the goal is for your sample of words to resemble the makeup of all words in the song.

When each student has picked ten words and computed the average of those ten words, ask them to come to the board (where you have drawn a horizontal axis to

record the mean length of the 10 words in each students sample—see picture below) and place a dot above the value corresponding to their average.

Note that the actual average length of the 158 words in the first two verses is 4.4 letters. The axis you draw should go from zero up to eight or nine letters. Based on the dot plot created on the board, ask students what they think the average lengths of the words are. You probably should see most samples have an average larger than four.

INCLUDED IN THE STUDENT MANUAL

“The Star-Spangled Banner”

What is the average length of a word in the “Star-Spangled Banner?”

The first two verses of the “Star-Spangled Banner” are given below. Your task is to select a sample of 10 words you will use to estimate the average length of all words in the first two verses of the song. Pick words that appear to be representative of the population of all the words. Circle the 10 words you choose.

What are the lengths (number of letters) for each of the 10 words you selected?

Note: Do not count apostrophes as letters. For example, “dawn’s” is a word that has a length of five. A hyphenated word, such as star-spangled, counts as a single word.

The “Star-Spangled Banner” (first two verses)

O say can you see, by the dawn’s early light,
What so proudly we hailed at the twilight’s last gleaming,
Whose broad stripes and bright stars through the perilous fight,
O’er the ramparts we watched were so gallantly streaming?
And the rocket’s red glare, the bombs bursting in air,
Gave proof through the night that our flag was still there,
O say does that star-spangled banner yet wave,
O’er the land of the free and the home of the brave?

On the shore dimly seen through the mists of the deep,
Where the foe’s haughty host in dread silence reposes,
What is that which the breeze, o’er the towering steep,
As it fitfully blows, half conceals, half discloses?
Now it catches the gleam of the morning’s first beam,
In full glory reflected now shines in the stream,
T’is the star-spangled banner, O long may it wave
O’er the land of the free and the home of the brave!

Calculate the average number of letters for the 10 words in your sample.

Record the average here:

Explore



After everyone has placed a dot on the plot, ask students to summarize the class results based on the shape of the dot plot. The dot plot should look fairly normal (symmetric and bell-shaped). Most importantly, the dot plot should be highest in the center, which is likely to be around five (higher than 4.4). Based on the shape, ask students what they expect the actual average word-length is. The class should come to a consensus that wherever the dot plot is centered is the most likely value for the average of all words.

This is also a good opportunity to ask students who had very high or small sample means, how they choose their sample. Ask some students in the middle of the dot plot how they choose their samples. Have students critique the methods used in trying to get unbiased samples. Perhaps a student even did this randomly! After students hear some good and bad strategies, suggest choosing samples randomly.

Now explain to students that you wish to estimate the average length of the words in the “Star-Spangled Banner” by another method. There are 158 words in the address. Ask students to pick 10 random numbers between one and 158. That should be random enough, but if you have technology available, you can ask students to generate 10 random numbers from one to 158 using a random number generator. Excel can perform this task using the function $=\text{RANDBETWEEN}(1,158)$. Then pass out the second page “Star Spangled Banner: Sampling Revisit” worksheet that assigns each word in the song a number between one and 158. Ask the students to find the words corresponding to their 10 randomly selected numbers and compute the average length of the 10 words corresponding to those numbers (not the average of the 10 numbers they choose). Again, if your class has less than 20 students, you may want to ask each student to do this twice. When they are done, ask them to come to the board and place a dot below the axis corresponding to the average length of the 10 words in their sample. You are likely to see a picture such as the one below:

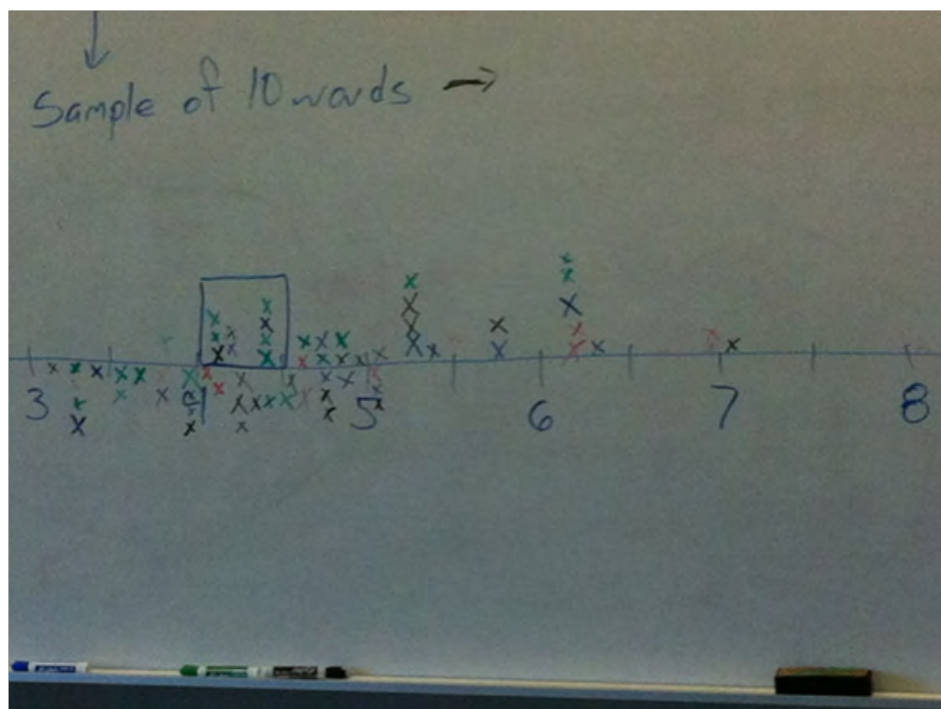

Notice in the image above, the dot plot above the axis (corresponding to human bias) has larger means than the random drawn samples below.

Ask students which they believe is a more accurate reflection? Then tell students that actual mean is 4.4 letters.

Why do they think the students generally had higher averages when they selected words they thought were representative of the population of all words as opposed to the generally smaller averages when they choose words randomly?

There are lots of reasons why this might have occurred. Have students share and critique each other's reasoning. Most common explanation is that our eyes are naturally drawn to larger objects than smaller, our eyes may be drawn to more meaningful words (star-spangled, ramparts), or perhaps we tend to notice the first word on each line (which tend to be longer than an average word). So we notice the larger words and tend not to pay attention to smaller words.

Explanation

Now define a couple of important statistical terms that students are familiar with, however they have very precise meaning in the context of statistics. Usually it is not feasible to gather data for an entire **population** (of words, people, trees, etc.). Instead data is gathered for a smaller subset of the population, called a **sample**, and this information is used to make a prediction about the population at large.

Just as it would take a lot of time to count the length of each word (without technology) and compute the average, it is not feasible to measure the height of every tree in a national park, or measure the weight of every elephant of a certain species. In order to save money, effort and time, if you can find a good way to select a representative sample, you can use the data from the sample to make predictions about the population.

- **Statistical inference** is the process of using data from a sample to gain information about the population.
- **Sampling bias** occurs when the method of selecting a sample causes the sample to differ from the population in some relevant way. If sampling bias exists, then we cannot trust generalizations from the sample to the population. **Ideally the goal is to obtain a sample that is identical to the population in every way only smaller in total size.**

What are the population and the sample in the “Star-Spangled Banner” activity? What are the cases? What is the variable? Is the variable quantitative or categorical?

The population is all 158 words in the first two verses of the song. The sample is the 10 words (selected by a human in round one, selected at random in round two). Each individual case is a word. The variable is the number of letters in each word (quantitative).

Relate the general terms and discussion of these terms to the example with the “Star-Spangled Banner”. For example, there was human sampling bias in round one. The samples had larger words than the population, and we could not safely generalize the results from our samples to the entire address. When we selected words at random, our samples were much more representative of the entire address.

Only random samples can truly be trusted when making generalizations to the population!

INCLUDED IN THE STUDENT MANUAL

“Star-Spangled Banner”: Sampling Revisited

Find each of the 10 words corresponding to the 10 random numbers (between one and 158) that have been assigned to you. Count the number of letters in each of these words and compute the average number of letters in the words in your sample.

O	say	can	you	see	by	the	dawn's	early	light
1	2	3	4	5	6	7	8	9	10
What	so	proudly	we	hailed	at	the	twilight's	last	gleaming
11	12	13	14	15	16	17	18	19	20
Whose	broad	stripes	and	bright	stars	through	the	perilous	fight
21	22	23	24	25	26	27	28	29	30
o'er	the	ramparts	we	watched	were	so	gallantly	streaming	And
31	32	33	34	35	36	37	38	39	40
the	rocket's	red	glare	the	bombs	bursting	in	air	Gave
41	42	43	44	45	46	47	48	49	50
proof	through	the	night	that	our	flag	was	still	there
51	52	53	54	55	56	57	58	59	60
O	say	does	that	star-spangled	banner	yet	wave	o'er	the
61	62	63	64	65	66	67	68	69	70
land	of	the	free	and	the	home	of	the	brave
71	72	73	74	75	76	77	78	79	80
On	the	shore	dimly	seen	through	the	mists	of	the
81	82	83	84	85	86	87	88	89	90
deep	Where	the	foe's	haughty	host	in	dread	silence	reposes
91	92	93	94	95	96	97	98	99	100
What	is	that	which	the	breeze	o'er	the	towering	steep
101	102	103	104	105	106	107	108	109	110
As	it	fitfully	blows	half	conceals	half	discloses	Now	it
111	112	113	114	115	116	117	118	119	120
catches	the	gleam	of	the	morning's	first	beam	In	full
121	122	123	124	125	126	127	128	129	130
glory	reflected	now	shines	in	the	stream	T'is	the	star-spangled
131	132	133	134	135	136	137	138	139	140
banner	O	long	may	it	wave	O'er	the	land	of
141	142	143	144	145	146	147	148	149	150
the	free	and	the	home	of	the	brave		
151	152	153	154	155	156	157	158		

Practice Together in Small Groups/Individually



INCLUDED IN THE STUDENT MANUAL

Task #2: Hours Spent Studying

Suppose you want to estimate the average number of hours that students in our school spend studying each week. Which of the following is the best method of sampling?

- Go to the library and ask all the students there how much they study.
- Email all students asking how much they study, and use all the data you get.
- Choose a sample of friends that resembles the general population of students at our school.
- Anonymously survey each student in our class. Require all students to respond.
- Stop people at random walking in the halls between classes and ask how much time they spend studying.

Possible Solutions:

- This would be a biased sample. Students in the library are likely to study more than the average student.
- Also biased. Some students chose to respond, others chose not to. The sample that responded are therefore not representative of the all students since it is reasonable to imagine that students that don't respond are likely to spend less time studying. This is called volunteer bias.
- Not randomly selected sample. Humans are not good at picking samples that resemble the population.
- Our class is not representative of all students in the school.
- Seems like the best of the five methods.



INCLUDED IN THE STUDENT MANUAL

Task #3: School Advisory Panel

From a class containing 12 girls and 10 boys, three students are to be selected to serve on a school advisory panel. Here are four different methods of making the selection.

- Select the first three names on the class roll.
- Select the first three students who volunteer.
- Place the names of the 22 students in a hat, mix them thoroughly, and select three names from the mix.
- Select the first three students who show up for class tomorrow.

Which is the best sampling method, among these four, if you want the school panel to represent a fair and representative view of the opinions of your class? Explain the weaknesses of the three you did not select as the best.

(<http://www.illustrativemathematics.org/illustrations/186>)

Commentary *for the Teacher:*

Most students will quickly settle on option III as the “best” method because it seems the “fairest” of the three. However, these students may not have a clear idea of what they mean by “best” or “fair.” Further discussion should lead to the idea that “fair” implies an equal chance of selection for any group of three students, which implies that any one student has the same chance of selection as any other student. Instructors could consider assigning the task to student pairs to initiate a think-pair-share exploration of the concomitant sampling issues or, if more in-depth student processing is desired prior to a classroom discussion, assign the task to small groups of three or four. A possible follow-up discussion is that randomness allows the use of probability models, a key concept in the statistical inference concepts that come later.

Possible Solutions

Option III is the best solution in terms of fairness because each of the other methods does not give equal chance of selection to all possible groups of three students. Explanations as to why the others are unfair may include comments such as the following:

- I. Names beginning with the same letter may belong to the same family or the same ethnic group.
- II. Volunteers may have special interest in a particular issue on which they want to focus.
- IV. Prompt-students may be the more serious students and perhaps would be the more conscientious members of a panel, but they may not be typical of students in the class. None of the three would allow me to be selected.

Evaluate Understanding

Call on a student and ask, “Who is your favorite teacher?”

Have your students look back at their work and recall the first 10 word samples they chose when attempting to approximate the average length of a word in the “Star-Spangled Banner.”

There are many other such questions you could pose with the intention of illustrating there are other reasons sample data can be biased. The question above illustrates what happens when responses are not anonymous.

There are many issues besides randomness that can lead to a sampling bias, such as:

- Sampling units (people) based on something clearly related to the variable(s) you are studying.
- Letting your sample be comprised of whoever chooses to participate (volunteer bias).
- The way a question is asked may introduce bias.
- Responses are not anonymous.

Closing Activity



A student at your school sends an email out to all 200 students asking students to reply whether or not they plan to go to college after graduating high school. Of 120 students responding, 81% said yes and 19% said no. Can you conclude that about 81% of all

Summarizing and Interpreting Statistical Data

Lesson 3 of 8

Correlation and Causation

Description:

Students explore the distinction between correlation and causation. Students learn the difference between observational studies and randomized experiments, and how they can affect whether or not causality can be established.

Georgia Standards of Excellence Addressed:

- MGSE9-12.S.ID.9: Distinguish between correlation and causation.
- MGSE9-12.S.IC.1: Understand statistics as a process for making inferences about population parameters based on a random sample from that population.
- MGSE9-12.S.IC.3: Recognize the purposes of and differences among sample surveys, experiments, and observational studies; explain how randomization relates to each.

Standard(s) for Mathematical Practice Emphasized:

- SMP 3: Construct viable arguments and critique the reasoning of others.
- SMP 4: Model with mathematics.
- SMP 6: Attend to precision.

Sequence of
Instruction

Activities Checklist

Engage



Write or project the instructions and statements below. Have students think individually at first.

INCLUDED IN THE STUDENT MANUAL

Correlation or Causation?

Decide whether each of the statement implies causation or simply association without causation. Identify whether each of the variables in the statement is a categorical or quantitative variable. Identify which variable is the explanatory and which is the response variable. Be sure to base your decision on the wording of the statement, not on your beliefs.

1. If you study more, your grades will improve.
2. Aging of the brain tends to be delayed in people with a college education.
3. Car owners tend to live longer than people who do not own a car.
4. A bad weather forecast leads to fewer students walking to school.
5. Seatbelts reduce the risk of a severe injury in a car accident.

Explore



After students have time to answer the problems above, place students in pairs and have them share answers.

While discussing the statements, ask the class to identify what the two variables are in each statement.

- Which is the explanatory variable?
- Which is the response variable?
- Is each variable quantitative or categorical?

Commentary *for the Teacher:*

The emphasis in this activity should be on determining causality or correlation. The questions about identifying variables are to keep these ideas fresh. If students have grasped the concepts of categorical and quantitative variables as well as identifying explanatory and response variables, you can skim over those ideas quickly in order to focus on the question of causality. It is easy to get bogged down in how the variables are measured (e.g., how is aging of the brain measured?). The point is, there are usually many ways to measure a variable.

In determining whether a statement implies causality or not, consider whether the verb is active (improves, leads, reduces) or passive (tends). Be sure you force students to base their decisions on the phrasing of the statements alone, not on any personal beliefs or experiences.

Solutions:

1. Causal. Study time is the explanatory variable, and grade is the response variable. Each could be measured quantitatively or categorically.
2. Not causal. Age is the amount of education is the explanatory variable, and aging of the brain is the response variable. Each could be measured quantitatively or quantitatively.
3. Not causal. Whether or not you own a car is the explanatory variable, and age at time of death is response variable. Whether or not you own a car is categorical. Age at time of death is quantitative.
4. Causal. Good or bad weather forecast is the explanatory variable and type of commute to school is the response variable. Both variables are measured categorically.
5. Causal. Whether or not a passenger/driver has a seatbelt on or not is the explanatory variable. Whether or not the person sustains a severe injury in a car accident is the response variable. If we consider that each variable is measured with “yes” or “no,” then both are categorical.

Explanation

After an informal discussion about the difference in a causal relationship as opposed to an association which is not causal, define the terms more formally. For example:

Two variables are **associated** or **correlated** if values of one variable tend to be related to the values of the other variable.

Two variables are **causally associated** if changing the value of one variable influences the value of the other.

Correlation does not always imply causation.

If students seem to pick up the concept quickly, you can ask students to work in pairs of to construct their own statement about two variables which are associated but not causally, as well as a statement about two variables that implies the association is causal.

If students are finding this concept difficult, be prepared with examples of associations that are and are not causal.

Practice Together in Small Groups/Individually



INCLUDED IN THE STUDENT MANUAL

Task #4: High Blood Pressure

In a study of college freshmen, researchers found that students who watched TV for an hour or more on weeknights were significantly more likely to have high blood pressure, compared to those students who watched less than an hour of TV on weeknights. Does this mean that watching more TV raises one's blood pressure? Explain your reasoning.

(<http://www.illustrativemathematics.org/illustrations/1100>)

Ask students to consider the following scenarios. In each case, ask students to identify the explanatory and response variables and indicate whether each are categorical or quantitative.

Commentary for the Teacher:

The purpose of this task is to assess understanding of how study design dictates whether a conclusion of causation is warranted. This study was observational and not an experiment, which means it is not possible to reach a cause-and-effect conclusion.

This task could be used as an assessment item, or it could be the basis of a small group or whole class discussion.

Possible Solution:

This does not mean that watching more TV raises blood pressure. Whether or not we can conclude that “watching more TV raises one's blood pressure” depends on the design of the study. If the researchers had conducted a randomized experiment where some of the participants were randomly assigned to watch less than an hour of TV and others were assigned to watch more than hour of TV, and if we found a statistically significant difference in the average blood pressure of the two groups, we could conclude causation. If the study is simply an observational study (which is the case here), we can only conclude that there is an association between time spent watching TV and blood pressure.

INCLUDED IN THE STUDENT MANUAL

Task #5: Pulse Rate

A biology class wants to determine whether exercising even for very small amount of time will lead to an increase in a student's pulse rate. Students are randomly assigned to two groups, exercisers and non-exercisers. Exercisers are asked to stand up and do jumping jacks for 20 seconds. After 20 seconds, all students count the number of beats in a minute. They average number of beats per minute as calculated separately for each group. Those that exercised even for just 20 seconds had a higher pulse rate. Based on the design of this study, can you conclude the exercise caused the pulse rate to increase?

▶ Commentary *for the Teacher:*

The purpose of this task is to assess understanding of how study design dictates whether a conclusion of causation is warranted. This study was a randomized experiment, which means the two groups (exercisers and non-exercisers, treatment and control) are very likely going to resemble each other in every way except for the amount of exercise (the treatment). Randomized, controlled experiments are great mechanisms to establish whether or not a causal association exists between two variables.

Possible Solution:

Since each person is randomly placed into one of the two groups, the two groups should be similar in all regards. Recall when we sampled words randomly, they were very likely to resemble the population of all words in the song. For the same reason, when the groups are decided randomly, they are very likely to resemble each other. If there is any difference in the response (pulse rate), it must be due to the only major difference in the two groups, namely the exercise (or lack thereof).

INCLUDED IN THE STUDENT MANUAL

Task #6: Golf and Divorce

Researchers have noticed that the number of golf courses and the number of divorces in the United States are strongly correlated and both have been increasing over the last several decades. Can you conclude that the increasing number of golf courses is causing the number of divorces to increase?

(<http://www.illustrativemathematics.org/illustrations/44>)

▶ Commentary *for the Teacher:*

These are simple tasks addressing the distinction between correlation and causation. Students are given information indicating a correlation between two variables, and are asked to reason out whether or not causation can be inferred.

Possible Solution:

No, we cannot conclude that the increasing number of golf courses is causing the number of divorces to increase. In general, correlation does not imply causation.

There are a number of factors that may be increasing the number of golf courses and

a number of factors causing of the rise in number of divorces. These factors may be (and are often) different. For example, there might be a rise in the popularity of the sport of golf that is in part causing the increase in the number of golf courses. However, the number of divorces might be increasing due in part to the relative ease with which one can obtain a divorce now, as opposed to say 10 years ago.

There may even be some global factors that are causing both numbers to increase, for example the rise in global population (i.e., there are more people on the planet earth, period). However, this rise in population would not necessarily create a link between the sport of golf and divorces.

Evaluate Understanding

The first case above is an example of an observational study. The second case is an example of a randomized experiment. Define each carefully.

An **observational study** is a study in which the researcher does not actively control the value of any variable but simply observes the values as they naturally exist (i.e., each student determines which group they are in based on how much TV they choose to watch).

In a **randomized experiment**, the value or category of the explanatory variable (exercise versus non-exerciser) for each case is determined randomly (e.g., flip of the coin where heads is exercise and tails is no exercise), before the response is measured.

Explain to students that it is difficult to avoid confounding in an observational study, so observational studies can almost never be used to establish causality. There is something inherently different in the groups besides their TV watching. Students that choose to watch more TV probably exercise less and do fewer after school activities. That is the cause of the higher blood pressure. So, there are differences in the two groups (watched TV more than one hour each weeknight compared to less than one hour) besides just the amount of TV. The difference in the response variable was due to these other variables **that are associated to both the explanatory and response variables**. It is these other variables that cause the high blood pressure, not watching the watching of TV itself.

At this point, you may choose to define a **confounding variable** as one that is associated to both the explanatory and response variables. When confounding exists, we cannot prove causation.

When researchers randomly assign people to groups (if the assignment is truly random) we should not expect any difference between the two groups other than the explanatory variable. For example it is not very likely that all athletes get heads and all of the less active students get tails. Groups are the same except for exercise.

Closing Activity



INCLUDED IN THE STUDENT MANUAL

Task #7: Strict Parents

Students in a high school mathematics class decided that their term project would be a study of the strictness of the parents or guardians of students in the school. Their goal was to estimate the proportion of students in the school who thought of their parents or guardians as “strict”. They do not have time to interview all 1,000 students in the school, so they plan to obtain data from a sample of students.

- Describe the parameter of interest and a statistic the students could use to estimate the parameter.
- Is the best design for this study a sample survey, an experiment, or an observational study? Explain your reasoning.
- The students quickly realized that, as there is no definition of “strict,” they could not simply ask a student, “Are your parents or guardians strict?” Write three questions that could provide objective data related to strictness.
- Describe an appropriate method for obtaining a sample of 100 students, based on your answer in part (a) above.

(<http://www.illustrativemathematics.org/illustrations/122>)

Commentary for the Teacher:

- Student responses should recognize that parameter is a numerical summary of a population and a statistic a numerical summary of a sample. The sample proportion is a natural statistic to use, but others are possible also. Some textbooks, for example, encourage the use of a “plus two” estimator for population proportions in which the numerator is the number of “yes” responses in the sample plus two, and the denominator is the sample size plus four.
- This part requires previous introduction to the terminology of study design.
- This is a good question to use for class discussion, as many issues arise. The question assumes that students will know why you can’t simply ask, “Are your parents or guardians strict?” But not all students will understand why this is a problem. Students should understand that the lack of an agreed-upon definition of “strict” means that answers to the questions may vary more than if there were a precise definition, and this will cause measurement error in the survey. Another possibility is that some students will not answer the question because the lack of a definition means they do not know how to answer. If so, there will be many non-responses in the sample, which could lead to a biased estimate. Finally, the instructor should be aware that students may suggest numerical questions (e.g., “How old were you when your parents allowed...?”), which raise the difficulty of analysis. The instructor may have to work to steer students toward yes/no questions (as in the solution) where the analysis concerns only the proportion of respondents who answer “yes.”
- It is important that the students’ answers indicate that a random sample be taken. Also, students should specify as precisely as possible a mechanism for obtaining a

sample. One “test” as to whether the answer is specific enough is whether another student could follow the directions unambiguously. Other sampling schemes are possible too. For example, students might specify cluster sampling, in which random samples are chosen from each class (freshman, sophomores, juniors, seniors.) Again, students should specify the mechanism for taking the random sample. One reason for requiring that students specify the mechanism used to collect the sample is that the term “random” is often used, colloquially, to mean “arbitrary” or “haphazard.” But taking an arbitrary sample can lead to bias in the sample. For this reason, students need to make it very clear that they understand what is meant by “random sample.”

Possible Solution:

- (a) The parameter of interest is the proportion of all 1,000 students at the school who have strict parents or guardians. A possible statistic to estimate this parameter is the proportion of students in the collected sample who have strict parents or guardians.
- (b) The best design would be a sample survey, because we are interested in estimating a population parameter, namely, the proportion of all parents at the school who are “strict”. It is less time consuming and costly to take a random sample of students than to interview all students at the school.
- (c) Answers will vary. “Do your parents require you to do your homework before you can meet with your friends?” “Do your parents require that you be home before 11:00 pm on a weekend night?” “Do your parents limit your mobile phone time?”
- (d) Answers will vary. A list of all students should be obtained from the principal’s office and a subset of student names should be taken from the list by randomly sampling without replacement. For example, the students could read triplets of digits from a random number table so that 000 represents the first student on the principal’s list and 999 represents the last. The students would begin at an arbitrary point in the table and then write down consecutive triplets until they had obtained the desired sample size. If a three-digit number is repeated, then they should skip that triplet and write down the next. Alternatively, a computer could be asked to take a random sample without replacement from the digits one through 1000.

INCLUDED IN THE STUDENT MANUAL

Task #8: Words and Music

A student interested in comparing the effect of different types of music on short-term memory conducted the following study: 80 volunteers were randomly assigned to one of two groups. The first group was given five minutes to memorize a list of words while listening to rap music. The second group was given the same task while listening to classical music. The number of words correctly recalled by each individual was then measured, and the results for the two groups were compared.

- a. Is this an experiment or an observational study? Justify your answer.
- b. In the context of this study, explain why it is important that the subjects were randomly assigned to the two experimental groups (rap music and classical music).

(<http://www.illustrativemathematics.org/illustrations/1029>)

Commentary *for the Teacher:*

The purpose of this task is to assess, (1) ability to distinguish between an observational study and an experiment, and (2) understanding of the role of random assignment to experimental groups in an experiment. For a brief, helpful description and example of why random assignment is important, see Guidelines for Assessment and Instruction in Statistics Education (GAISE) Report, ASA, 2007, page 54.

Possible Solution:

- a. This is an experiment, because a treatment (type of music) was imposed on the subjects.
- b. We randomly assign subjects to groups in order to create two groups that are as similar as possible with respect to any variables that might influence the subjects' capacity for recalling words. That way, any differences we see in the mean number of words recalled can be attributed to either the type of music or to variation arising from random assignment. For example, if subjects were not assigned at random and were allowed to choose which music group they wanted to participate in, people who are easily distracted and may have more difficulty memorizing a list of words may tend to choose the classical music group because there are usually no lyrics that might distract in classical music.

Independent Practice:

If you run out of time, you can assign one (or both) of the closing activities for work at home.

You can ask students to find an article online which explains an experiment and an article that describes an observational study. Ask students to identify variables (explanatory, response and possibly confounding), whether there was an association and whether that association is causal or not. Did the article falsely claim causality in the case of the observational study?

Notes:

Handout Cell Phones 1 assessment task from Shell Center Formative Assessment "Representing Data 1: Using Frequency Graphs." This assessment needs to be collected with enough time so you can assess student work prior to beginning Lesson 5 when the full formative assessment will take place. See Lesson 5.

Summarizing and Interpreting Statistical Data

Lesson 4 of 8

Analyzing Relationships Between Two Categorical Variables

Description:

Using data collected from the student survey in lesson one, students create a model using two-way tables as a tool to in helping determine whether there seems to be convincing evidence for correlation between two categorical variables. The distinction between correlation and causation is revisited, as is experiment design.

Georgia Standards of Excellence Addressed:

- MGSE9-12.S.ID.5: Summarize categorical data for two categories in two-way frequency tables. Interpret relative frequencies in the context of the data (including joint, marginal, and conditional relative frequencies). Recognize possible associations and trends in the data.

Standard(s) for Mathematical Practice Emphasized:

- SMP 1: Make sense of problems and persevere in solving them.
- SMP 2: Reason abstractly and quantitatively.
- SMP 3: Construct viable arguments and critique the reasoning of others.
- SMP 4: Model with mathematics.

Sequence of
Instruction

Activities Checklist

Engage



The opening activity will be based on data collected from the survey at the start of this unit. If you customized the survey, pick categorical variables that would be interesting to look at further. Interest should be based on mathematical merit and interest in context. See the example here to identify some of the mathematics that can be illustrated with this activity. No matter what, you have to choose two categorical variables. This activity is based on seeing whether left-handed people are more likely to use Mac than right-handed people.

Ask students to identify the variables, decide whether they are categorical or quantitative and identify which is the explanatory and response? Ask students whether they believe there will be an association and whether that association is causal or not.

Show the results of the left-handed versus right-handed data collected. Bar charts and pie charts would be reasonable ways to display the data. You can also display the “raw” data to make the point about why visual representations are nice, especially in large datasets.

1	L	Mac
2	R	PC
3	R	PC
4	R	PC
5	R	PC
6	L	Mac
7	R	PC
8	R	PC
9	R	PC
...
25	R	Mac

Comparing Mac and PC Users

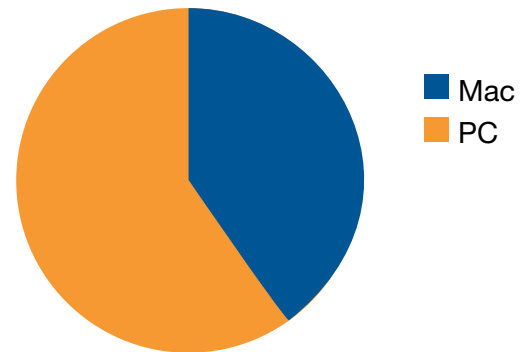

Pie charts work just fine when you wish to display one categorical variable, but what if you want to display the relationship between two different categorical variables, such as handedness or computer operating system.

We can use what is called a **two-way table**.

Explore



INCLUDED IN THE STUDENT MANUAL

Left or Right Handed? Mac or PC?

Display the data in a two-way table such as the one below.

	Left	Right	Total
Mac	2	8	10
PC	1	14	15
	3	22	25

And ask students to answer the following questions. You may need to double check students are clear how to read the columns and rows. Each category of the response variable in this example is displayed as a separate column. Each category of the explanatory variable is displayed as a separate column.

INCLUDED IN THE STUDENT MANUAL

1. What proportion of students is left-handed? Right-handed?
2. What proportion of students use a Mac? A PC?
3. What proportion of students is left-handed and use a Mac?
4. What proportion of Mac users is right-handed?
5. What proportion of Mac users is left-handed?
6. What proportion of right-handed students use a Mac?
7. What proportion of left-handed students use a Mac?

8. If we want to determine whether left-handed people are more likely to use a Mac than right-handed people, which pair of proportions is more relevant to consider, the proportions in questions four and five or the proportions in six and seven? Why?
9. Do you think the difference is significant?

Explanation

The point here is we don't compare proportions in questions four and five. Of course many more Mac users were right-handed; most people in the class are right-handed. So, we need to take into account the difference in size of the two groups (right and left). Proportions in questions six and seven take into account the difference in size of the two groups since the denominators of the proportions we are considering are the total number of cases that fell in each group (total in each column, explanatory variable).

Since $\frac{2}{3} = 0.66$ and $\frac{8}{22} = 0.36$, we can see that left-handed students do seem to be more likely to use a Mac than right-handed people.

You could also explain the difference between a proportion and percentage at this point if it comes up.

If you chose, you can also introduce the notation $P(A)$ and $P(A|B)$. It is not essential, so we leave it out here. It certainly can be worked in and it might help clear up the idea that $P(\text{Mac} | \text{Left}) = \frac{2}{3}$ has three as the denominator since three students were left-handed.

Practice Together in Small Groups/Individually



INCLUDED IN THE STUDENT MANUAL

Task #9: Titanic Survivors

On April 15, 1912, the Titanic sank after tragically striking an iceberg. The two-way table below breaks down the likelihood of survival by class of passenger.

	Survived	Did Not Survive	Total
1st Class	203	122	325
2nd Class	118	167	285
3rd Class	178	528	706
Crew	212	673	885
Total	711	1490	2201

Discuss whether the following statement is accurate. If so, use proportions from the table above to support the statement. If the statement is not accurate, explain why?

“Since more crew survived (212) than any other class, the crew were more likely to survive the sinking than any class of passenger.”

Evaluate Understanding

Commentary for the Teacher:

This has the same exact issue as in the opening activity. Just because more crew (in absolute terms) survived this does not mean their odds of surviving were necessarily better. More crew survived because they were the largest population on the boat (885). In order to determine whether the crew are more likely to survive than any other group, we would need to compare the following proportions.

Possible Solution:

$$P(\text{Survive} \mid 1\text{st}) = \frac{203}{325} = 0.625$$

$$P(\text{Survive} \mid 2\text{nd}) = \frac{118}{285} = 0.414$$

$$P(\text{Survive} \mid 3\text{rd}) = \frac{178}{706} = 0.252$$

$$P(\text{Survive} \mid \text{Crew}) = \frac{212}{885} = 0.240$$

The proportions above seem more in line with what we would expect, namely the first class passengers are most likely to survive followed by second class passengers, and so on.

Follow up to Task #8:

Before moving on to the next activity, connect concepts from previous lessons to the Titanic example (especially if students are still having difficulty with key concepts in lessons one through three). For example, you could ask:

- What are the cases in this dataset? What are the variables?
- Determine whether each variable is categorical.
- Which variable is the explanatory and which is the response variable?
- Based on the proportions above, do you believe there is a correlation between class of passenger and survival? If so, is the association causal?

Solution:

- Cases are the passengers and variables are class and survival.
- Both are categorical. A two-way is only appropriate when you were analyzing the relationship between two categorical variables. If either one of the variables is quantitative, you have other tools at your disposal to use. You will be introduced to these other tools in the next several lessons.
- Class is the explanatory variable, and survival is the response variable.
- You see that the proportion of passengers that survived decreases as the class of the passenger increases. This gives good evidence that indeed there is a correlation between these two variables. Since this is an observational study (passengers chose their class), we can determine this is causal. There are too many confounding variables. For example, first class passengers had cabins higher up on the ship, and therefore they were able to make it to a life boat quicker. First class passengers were also more likely to be able to swim.

Closing Activity



At this point, you can choose more data from the class survey if you have good examples (choosing two categorical variables).

Otherwise, here is another example:

INCLUDED IN THE STUDENT MANUAL

Task #10: Vaccine Recipients

In a study of 500 children from a city, 238 were randomly selected to receive a new vaccine. The other 262 children were randomly selected to receive a placebo. The children and the physicians did not know to which group they have been assigned.

After five years, 22 of the 238 children who received the vaccine had been infected with malaria; while 28 out of the 262 children who received the placebo had been infected with malaria.

- Is this an experiment or an observational study?
- What are the variables? Which are categorical/quantitative? Explanatory/response?
- Using the information above, set up a two-way table to determine whether the vaccine is effective.
- Use your two-way table to determine whether the vaccine is effective or not.
- Do you believe the vaccine is effective?

Possible Solution:

- This is an experiment since the researchers decided (randomly) who is assigned to the vaccine group and who is assigned to the placebo group.
- Whether or not a child receives a vaccine is the explanatory variable. It is also a categorical variable. Whether or not a child becomes infected with malaria is the response variable. It is categorical as well.

c.

	Vaccine	Placebo	Total
Gets Malaria	22	28	50
No Malaria	216	234	450
Total	238	262	500

- Just because six more children who received the placebo became infected with malaria than the children who received the vaccine, does not mean the vaccine is not effective. More children in the experiment received the placebo, so it is not that unusual that more of the placebo group got malaria (there is more of them.) Instead, we should compare proportions since that will take into account the different size of each group.

Proportion who received the vaccine who get malaria is $22/238 = 0.092$

Proportion who received the placebo who get malaria is $28/262 = 0.107$

It appears the group who received the placebo is indeed less likely to get malaria. Because this is a randomized experiment, the only major difference between the two groups (vaccine and placebo) is the vaccine itself. This provides good evidence that the vaccine reduces the risk of becoming infected with malaria.

Independent Practice:

INCLUDED IN THE STUDENT MANUAL

Task #11: Musical Preferences

The 54 students in one of several middle school classrooms were asked two questions about musical preferences: “Do you like rock?” “Do you like rap?” The responses are summarized in the table below.

	Likes Rap	Doesn't Like Rap	Total
Likes Rock	27	6	33
Doesn't Like Rock	4	17	21
Total	31	23	54

- Is this a random sample, one that fairly represents the opinions of all students in the middle school?
- What percentage of the students in the classroom like rock?
- Is there evidence in this sample of an association in this class between liking rock and liking rap? Justify your answer by pointing out a feature of the table that supports it.
- Explain why the results for this classroom might not generalize to the entire middle school.

(<http://www.illustrativemathematics.org/illustrations/123>)

Commentary *for the Teacher:*

There is a variety of approaches to (c) and answers may vary considerably. The basic idea is for students to demonstrate that they know what it means for two variables to be associated; if we knew someone were in one group (e.g., they like rap), we now know more about their preferences for rock than if we knew nothing at all.

A productive follow-up discussion is to ask students what sort of numbers they would see in the table if there were no association. If there were no association, we'd see that about 60% of the students like rap in both the "like rock" and "do not like rock" groups. A common mistake is for students to think that if there is no association, the overall percentages of those who like rock must be the same as the overall percentage of those who like rap. Another common mistake is for students to think that a lack of association means that all percentages must be 50%.

Students will wonder how close the percentages must be to conclude that there is no association. For example, suppose 61% of those who like rap also like rock, and 60% of those who do not like rap like rock. Is this "close enough" to conclude there is no association? This is a question that is answered when students learn about inference and learn to compare two proportions. Because there is no hard-and-fast rule, the question is phrased to ask whether there is evidence of an association but does not ask whether there is an association.

Note that if there were more than three categories for responses in either of the two variables (i.e., "likes rap", "does not like rap", "no preference"), the question is more complicated because more categories must be considered.

Possible Solution:

- This is not a randomly selected sample that fairly represents the students in the school. See part (d) for more details.
- $\frac{33}{54} = 61.1\%$.

Summarizing and Interpreting Statistical Data

Lesson 5 of 8

Formative Assessment Lesson: Presenting Data I: Using Frequency Graphs

Description:

This lesson unit is intended to help you assess how well students:

- Are able to use frequency graphs to identify a range of measures and make sense of this data in a real-world context.
- Understand that a large number of data points allow a frequency graph to be approximated by a continuous distribution.

Georgia Standards of Excellence Addressed:

- MGSE9-12.S.ID.1: Represent data with plots on the real number line (dot plots, histograms, and box plots).
- MGSE9-12.S.ID.2: Use statistics appropriate to the shape of the data distribution to compare center (median, mean) and spread (interquartile range, mean absolute deviation, standard deviation) of two or more different data sets
- MGSE9-12.S.ID.3: Interpret differences in shape, center, and spread in the context of the data sets, accounting for possible effects of extreme data points (outliers).

Standard(s) for Mathematical Practice Emphasized:

- SMP 1: Make sense of problems and persevere in solving them.
- SMP 2: Reason abstractly and quantitatively.
- SMP 3: Construct viable arguments and critique the reasoning of others.

The following *Formative Assessment Lesson* is a classroom-ready lesson included to help teachers assess and improve students' understanding of mathematical concepts and skills and their ability to use the "mathematical practices" described in the College Readiness Standards. Research has shown that formative assessment, as embodied in the following lesson, is a powerful way to improve student learning and performance. This approach first allows students to demonstrate their prior understandings and abilities in employing the mathematical processes, and then resolve their own difficulties and misconceptions through structured discussion. This results in more secure long-term learning, reducing the need for re-teaching that otherwise takes so much classroom time. Many often ask, why don't students just remember the procedures they have been taught and practiced? The fact is, that approach works fine in the short term but, as every teacher knows, if procedural knowledge is not underpinned by conceptual understanding, students will quickly forget "how to do it." Read more about the *Formative Assessment Lesson* rationale, structure, and philosophy using the *Brief Guide for Teachers and Administrators* that can be found at <http://map.mathshell.org/materials/index.php>.

CONCEPT DEVELOPMENT

Mathematics Assessment Project
CLASSROOM CHALLENGES
A Formative Assessment Lesson

Representing Data 1: Using Frequency Graphs

Mathematics Assessment Resource Service
University of Nottingham & UC Berkeley
Beta Version

For more details, visit: <http://map.mathshell.org>
© 2012 MARS, Shell Center, University of Nottingham
May be reproduced, unmodified, for non-commercial purposes under the Creative Commons license
detailed at <http://creativecommons.org/licenses/by-nc-nd/3.0/> - all other rights reserved

BEFORE THE LESSON

Assessment task: Cell Phones 1 (20 minutes)

Give this task, in class or for homework, a few days before the formative assessment lesson. This will give you an opportunity to assess the work and to find out the kinds of difficulties students have with it. You will then be able to target your help more effectively in the lesson.

Give each student a copy of the assessment task: *Cell Phones 1*.

Read through the questions and try to answer them as carefully as you can.

It is important that, as far as possible, students are allowed to answer the questions without your assistance.

Students should not worry too much if they cannot understand or do everything because, in the lesson, they will engage in a similar task that should help them. Explain to students that by the end of the next lesson they should expect to answer questions such as these confidently. This is their goal.

Cell Phones 1

Here is a frequency graph that shows the monthly spending of a group of students on their cell phones:

Amount spent (\$)	Frequency
0	0
4	0
8	0
12	2
16	5
20	10
24	20
28	40
32	50
36	20
40	0

The graph shows:

A range of spending of about

I know this from the graph because

.....

The mode is about

I know this from the graph because

.....

The median is about

I know this from the graph because

.....

Most students spend over

I know this from the graph because

.....

.....

Assessing students' responses

Collect students' responses to the task and note down what their work reveals about their current levels of understanding, and their different approaches.

We suggest that you do not score students' work. The research shows that this will be counterproductive, as it will encourage students to compare their scores and distract their attention from what they can do to improve their mathematics.

Instead, help students to make further progress by summarizing their difficulties as a series of questions. Some suggestions for these are given on the next page. These have been drawn from common difficulties observed in trials of this unit.

We suggest that you write a list of your own questions, based on your students' work, using the ideas in the *Common issues* table. We recommend that you write questions on each individual student's work. If you do not have time to do this, select a few questions that will be of help to the majority of students. These can be written on the board at the start of the lesson.

Common issues	Suggested questions and prompts
<p>Student provides an incorrect range For example: The student writes 5 - 40. Or: The student assumes the range is the difference between the maximum and zero.</p>	<ul style="list-style-type: none"> • What is the definition of the term ‘range’?
<p>Student uses the frequency readings for the measures of central tendency For example: The student writes that the mode is 48.</p>	<ul style="list-style-type: none"> • What does the vertical axis represent? • What measure is the question asking for?
<p>Student does not understand the word ‘Frequency’ For example: The student assumes ‘Frequency’ represents a percentage.</p>	<ul style="list-style-type: none"> • What does the term ‘frequency’ mean? • What does the axis marked ‘frequency’ represent on the graph?
<p>Student does not understand what median represents or how to use the graph to figure out the median For example: The student assumes the median value is equal to the mode. Or: The student assumes the median value is exactly half way between the maximum and minimum value.</p>	<ul style="list-style-type: none"> • What does the median represent? • Can the mode and median values be different? • Roughly what proportion of students spends less than the median value? • Sketch on the graph the results of a different survey. In this survey the maximum and minimum values for the amount spent each month remains the same, but the number of students in the survey is half/double. What does this tell you about the area under the graph? • How can you show the median value on your graph? [Draw a vertical line to divide in half the area under the graph. The median amount is the value at the point this line intersects the x-axis.]
<p>Student does not contextualize the data For example: The student states the mode is 31, the minimum and maximum values are 5 and 40 respectively, but does not refer to the context.</p>	<ul style="list-style-type: none"> • What do these figures represent? • Complete this sentence “50% of students spend less than \$___ each month.” Explain how you arrived at the figure.

SUGGESTED LESSON OUTLINE

Throughout this lesson, encourage students to use the correct mathematical language to not just **provide** the figure for a measure, but to **place the figure in the context**. For example, rather than “The median is 20”, encourage students to say “The median score is 20 out of 100.”

Whole-class interactive introduction: Drawing and Interpreting Graphs (20 minutes)

Give out the sheet *Drawing Graphs*. Maximize participation in the introduction by asking all students to show you their graphs once sketched.

This introduction will provide students with a model of how they should justify their matching of cards in the collaborative activity. It will also help students understand how to identify a range of measures from a graph and in particular the median value.

Often students think that the median should be the middle score of the range of scores. The first task in this introduction helps demonstrate that this is not always the case.

Show Slide P-1 of the projector resource:

Bar Graphs

- Eleven students take a test.
- The test is out of 10.
- All students scored more than 5.
- At least one student scored each mark between 6 and 10.
- The mode is 9 out of 10.

Sketch on the *Drawing Graphs* handout two bar graphs that could represent the results of the test.

- On the first graph make sure the median is equal to the mode.
- On the second graph make sure the median is different from the mode.

Sketch on your sheet two bar graphs that could represent the test results.

On the first make sure the median is equal to the mode.

On the second the median should be different from the mode.

If students struggle, encourage them to discuss the task with a neighbor. It may help if they write down the value of the eleven scores.

After a few minutes ask students to show you their graphs and select two or three students with different graphs to justify them to the class. Ask the rest of the class if they agree with the explanations.

You may want to use Slide P-2 of the projector resource, *Mode and Median*, to support the discussion.

How can you check that eleven students took the test?

How many students achieved the median score or less? How do you know?

What is meant by the statement ‘the median is the middle score?’ [The middle score of a sorted list of scores.]

Could the median score ever be equal to the minimum or maximum score? [Yes, but the mode would not be 9 out of 10.] How do you know?

Show Slide P-3 of the projector resource:

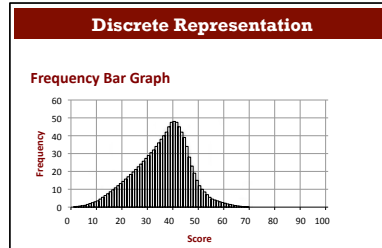

Explain to students that the bar chart represents the scores of students in a test for in which the maximum score was 100. Ask the following questions in turn:

Did anyone achieve the maximum score of 100? How can you tell?

What can you say about the test? Did students find it difficult or easy? How can you tell?

Roughly how many students took the test? [About 1,000.] How can you tell?

Show Slide P-4 of the projector resource:

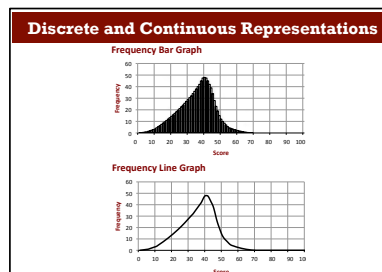

When there are many bars close together the data can be represented as a continuous line, that is, a frequency graph. This makes it a little easier to read off the values.

Show Slide P-5 of the projector resource:

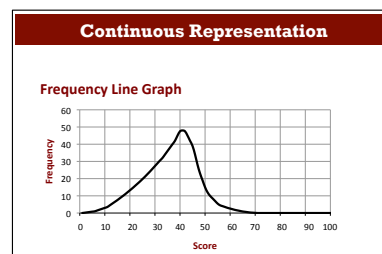

Students write on their mini-whiteboards all the information they can derive from the graph. After a couple of minutes ask students to show you their answers.

Ask one or two students to justify their answers. Even if their explanations are incorrect or only partially correct, ask students to write them on to the projected graph. Encourage students to challenge these interpretations and then replace them with new ones.

Depending on your class, you may want to ask students a selection of the following questions:

What is the range of scores? [About 64 out of 100.] How do you know?

What is the mode score? [42 out of 100.] How do you know?

What is the range of scores for most students? [Most people scored between 30 and 50 out of 100.]

How do you know? [A large proportion of the area under the graph is between 30 and 50 out of 100.]

What does the area under the graph represent? [The number of people in the survey.]

To confirm that students understand that the area under the graph represents the number of people in the survey you could ask them to sketch a graph on their whiteboard for another set of test results, but this time only half the number of students taking the test. The minimum and maximum scores remain the same

Now return to the original graph:

Roughly what is the median score? [37 out of 100.] How do you know?

What is the range of scores for the top quarter of students?

[About 22 (66 – 44) out of 100.] How do you know?

To answer these final two questions, the area under the graph needs to be divided in half/quarters by vertical lines extending from the x -axis. For students to figure out these values it may help if you project the bar graph of the data.

If students find it difficult to figure out an estimate for the median, add a vertical line to the graph that intersects the x -axis at, say, a score of 20 out of 100. Then ask student to estimate how many children scored less than 20.

Can this be the median score? How do you know?

The graph may end up looking like this:

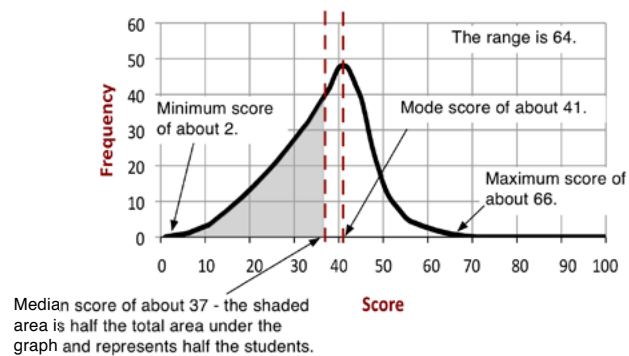

Collaborative activity: Matching Card Sets (20 minutes)

Ask students to work in small groups of two or three.

Give each group Card Set: *Frequency Graphs*, Card Set: *Interpretations*, and a large sheet of paper for making a poster.

Take turns at matching pairs of cards that you think belong together.

Each time you do this, explain your thinking clearly and carefully. Your partner should either explain that reasoning again in his or her own words, or challenge the reasons you gave.

Write your reasons for the match on the poster.

Place your cards side by side on your large sheet of paper, not on top of one another, so that everyone can see them.

You both need to be able to agree on and explain the placement of every card.

These instructions are summarized on Slide P-6 of the projector resource, *Matching Cards*.

The purpose of this structured work is to encourage each student to engage with their partner's explanations and to take responsibility for their partner's understanding.

While students work in small groups you have two tasks: to note different student approaches to the task and to support student reasoning.

Note different student approaches to the task

In particular, notice any difficulties that students encounter, and the ways they justify and explain to each other. Do students check to see if their match is correct? Do they assume the scores go up the vertical axis? How do they understand how to use the graph to figure out the median and mode? When stating a measure, do students confuse the values on the x -axis and y -axis? Are students using the correct mathematical language? Are students using all the information on the cards or just the first sentence? What do they do if they get stuck?

You can then use this information to focus your questioning in the whole-class discussion towards the end of the lesson.

Support student reasoning

Try not to make suggestions that move students towards particular matches. Instead, ask questions to help students to reason together. You may want to use some of the questions and prompts from the *Common issues* table.

If a student struggles to get started encourage them to ask a specific question about the task. Articulating the problem in this way can sometimes offer a direction to pursue that was previously overlooked. However, if the student needs their question answered, ask another member of the group for a response.

Here are some further questions you may want to use:

Rewrite the description in your own words.

Write a description of the graph.

*Tell me how you have used **all** the information [i.e. both sentences] on the Interpretation card to match it with a graph.*

How can you figure out an approximate value for the median?

Did many students get a low/high score for this graph? How do you know?

Show me a graph that shows the median score equal to the mode score. How do you know?

Show me a graph that shows the median score different to the mode score. How do you know?

Show me a graph in which a lot of students/few students found it easy. How do you know?

Show me a graph that shows the median score equal to the minimum score. How do you know?

Which graph shows students of a similar ability? How do you know?

Make up five figures where the median is greater than the mode. Now sketch a graph of these figures.

If you find one student has matched two cards, challenge another student in the group to provide an explanation.

Danny matched these cards. Ezra, why does Danny think these two cards go together?

If you find the student is unable to answer this question, ask them to discuss the work further. Explain that you will return in a few minutes to ask a similar question.

If the whole-class is struggling on the same issue you could write a couple of questions on the board and hold a whole-class discussion.

Sharing posters (10 minutes)

As students finish matching the cards, ask one student from each group to visit another group's poster.

If you are staying at your desk, be ready to explain the reasons for your group's decisions.

If you are visiting another group, copy your matches onto a piece of paper. Go to the other group's desk and check to see which matches are different from your own. If there are differences, ask for an explanation. If you still don't agree, explain your own thinking. When you return to your own desk, you need to consider as a group whether to make any changes to your poster.

Slide P-7 of the projector resource, *Sharing Posters*, summarizes these instructions.

When students are satisfied with all their matches give them a glue stick and ask them to glue the cards onto the poster.

Whole-class discussion (15 minutes)

You may want to use transparencies of the cards or Slide 8 of the projector resource to support the discussion.

The intention is that this discussion focuses on the justification of a few examples, rather than checking students all have the correct solutions. You may want to first select a pair of cards that most groups matched correctly as this may encourage good explanations. Then select one or two matches that most groups found difficult. In trials students have had difficulty matching graphs B, C, and H.

How did you decide to match this card?

Can someone else put that into his or her own words?

Could this card be matched with another one?

After discussing two or three matches ask:

Which graph card do you think is unrealistic? Why?

Now ask students to sketch on their whiteboard a graph that shows the test results of a different class. The first piece of information about the test is that there is a huge range of scores.

Once students have shown you their whiteboards ask them to swap whiteboards with a neighbor and write a second piece of information about the test on their neighbors' whiteboard. This piece of information, combined with the first, should make their existing graph incorrect.

Once whiteboards are returned students will need to re-draw their graph so that it represents both pieces of information.

Ask students to show you their whiteboards. Ask a few students with differing graphs to explain why they were forced to re-draw it.

Follow-up lesson: Reviewing assessment (20 minutes)

Return the original assessment *Cell Phones I* to the students together with a copy of *Cell Phones I (revisited)*. If you have not added questions to individual pieces of work, write your list of questions on the board. Students should select from this list only those questions they think are appropriate to their own work. Some students may struggle to identify which questions they should consider from this list. If this is the case it may be helpful to give students a printed version of the list of questions so that you can highlight the ones that you want them to focus on.

*Look at your original responses and the questions (on the board/written on your script.)
Think about what you have learned.*

Now look at the new task sheet, Cell Phones I (revisited). Use what you have learned to answer these questions.

When you revise your work, write as if you are explaining the solutions to someone unfamiliar with this type of math.

SOLUTIONS

Assessment task: Cell phones I

All answers are approximate.

The range is about \$35 a month. I know this from the graph because the range represents the difference between the maximum (\$40 a month) and minimum (\$5 a month) amount spent each month.

The mode is about \$31 a month. I know this from the graph because the maximum frequency is about \$31 a month.

The median is about \$29 a month. I know this from the graph because if I drew a vertical line from this point on the x -axis it would divide in half the area under the graph. The area under the graph represents the number of students in the survey. This means about half the students spent less than \$29 a month and half spent more than \$29 a month.

Most students spend over \$24 a month. I know this from the graph because the area under the graph up to \$24 is a lot less than the area under the graph between \$24 and \$40.

Collaborative activity:

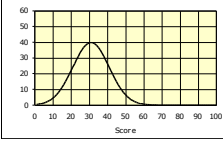
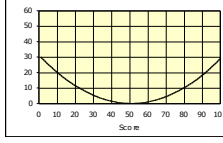
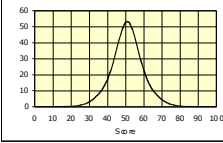
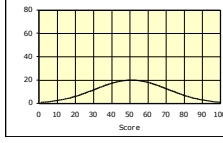
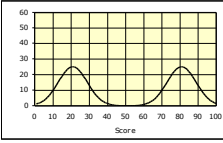
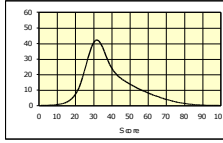
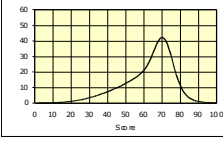
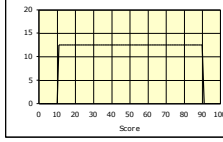
<p>A</p> 	<p>8.</p> <p>This test was much too difficult for most people.</p>	<p>B</p> 	<p>1.</p> <p>This was the sort of test where you could either do everything or you couldn't get started.</p>
<p>C</p> 	<p>2.</p> <p>This test did not sort out the stronger students from the weaker ones. They all got similar scores.</p>	<p>D</p> 	<p>7.</p> <p>In this test, the median and the mode scores were the same. There was a very big range of scores.</p>
<p>E</p> 	<p>3.</p> <p>Two groups of students took the test. One group had studied the work for two years. The other group had only just begun.</p>	<p>F</p> 	<p>5.</p> <p>In this test, the median score was greater than the mode score.</p>
<p>G</p> 	<p>6.</p> <p>In this test, the median score was smaller than the mode score.</p>	<p>H</p> 	<p>4.</p> <p>This test resulted in a huge range of scores. Everyone could do something but nobody could do it all.</p>

Assessment task: Cell phones 1 (revisited)

All answers are approximate.

The range is about \$38 a month. I know this from the graph because the range represents the difference between the maximum (\$44 a month) and minimum (\$6 a month) amount spent.

The mode is about \$23 a month. I know this from the graph because the maximum frequency is about \$23 a month.

The median is about \$18 a month. I know this from the graph because if I drew a vertical line from this point on the x -axis it would divide in half the area under the graph. The area under the graph represents the number of students in the survey. This means about half the students spent less than \$18 a month and half spent more than \$18.

Very few students spend over \$30 a month. I know this from the graph because the area under the graph from \$30 to \$44 is a lot less than the area under the graph between \$6 and \$30.

Cell Phones 1

Here is a frequency graph that shows the monthly spending of a group of students on their cell phones:

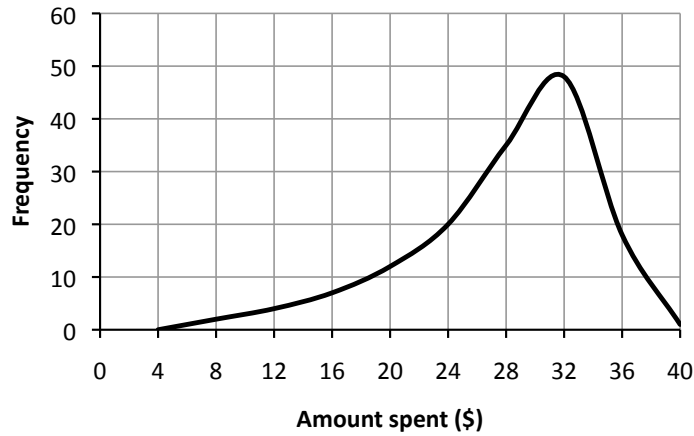

The graph shows:

A range of spending of about

I know this from the graph because

The mode is about

I know this from the graph because

The median is about

I know this from the graph because

Most students spend over

I know this from the graph because

Drawing Graphs

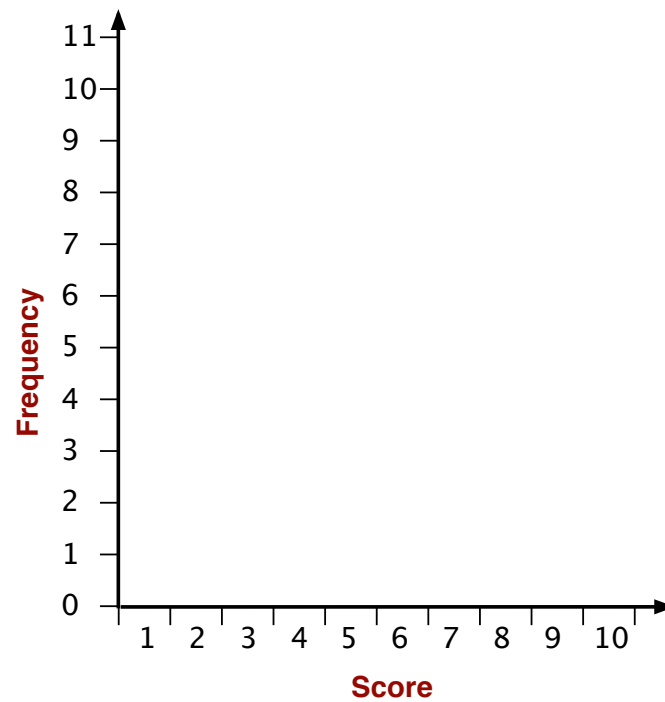
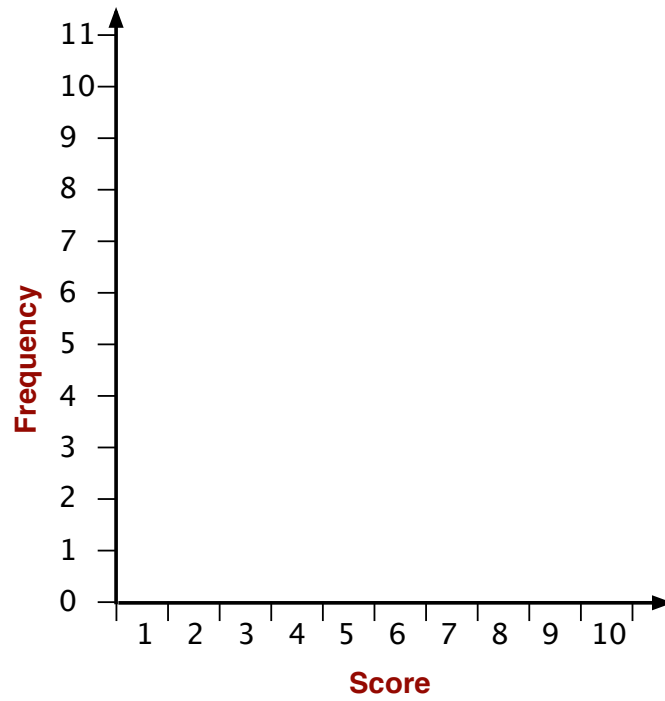

Card Set: Frequency Graphs

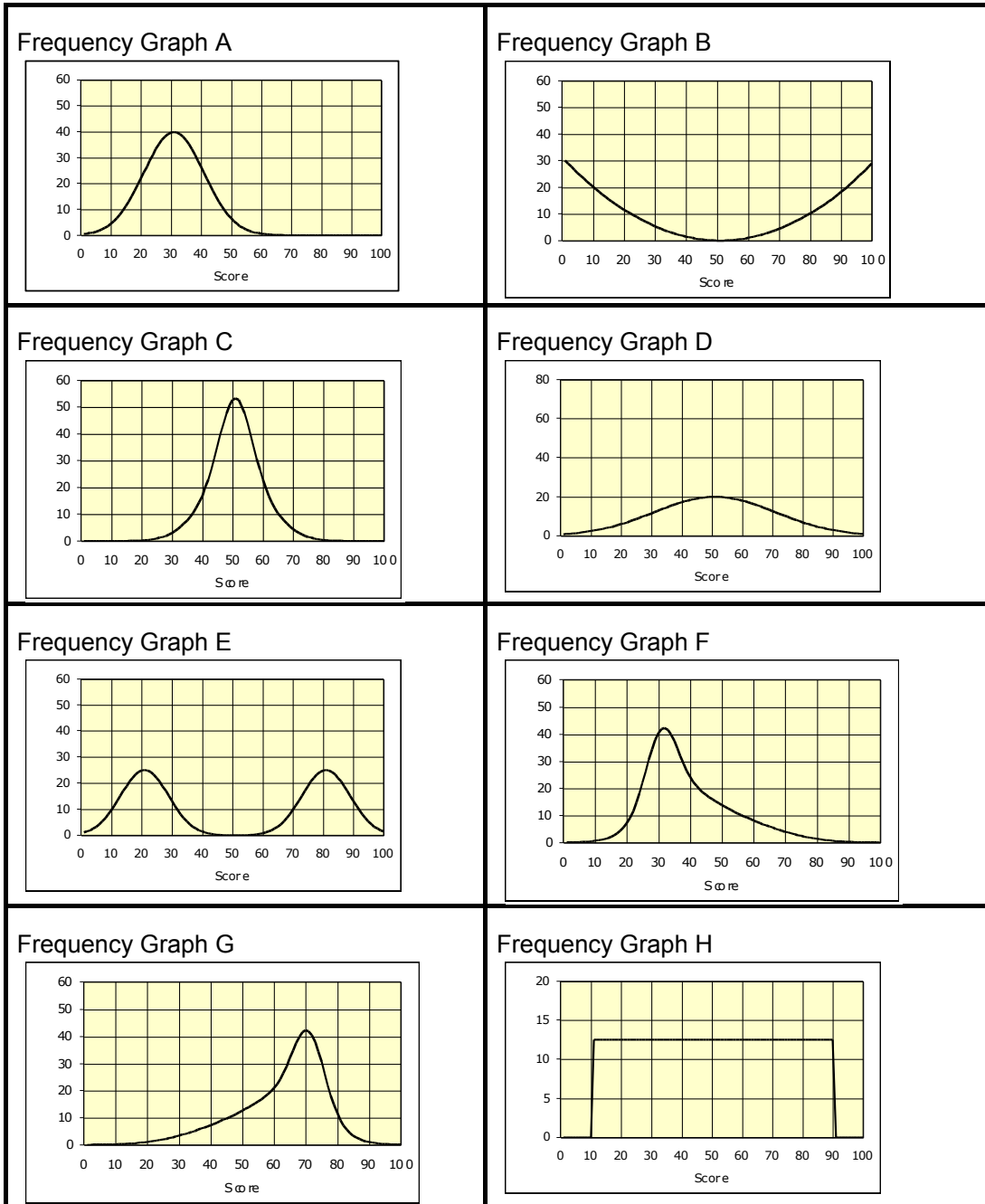

Card Set: Interpretations

1. This was the sort of test where you could either do everything or you couldn't get started.	2. This test did not sort out the stronger students from the weaker ones. They all got similar scores.
3. Two groups of students took the test. One group had studied the work for two years. The other group had only just begun.	4. This test resulted in a huge range of scores. Everyone could do something but nobody could do it all.
5. In this test, the median score was greater than the mode score.	6. In this test, the median score was smaller than the mode score.
7. In this test, the median and the mode scores were the same. There was a very big range of scores.	8. This test was much too difficult for most people.

Cell Phones 1 (revisited)

Here is a frequency graph that shows the monthly spending of a group of students on their cell phones:

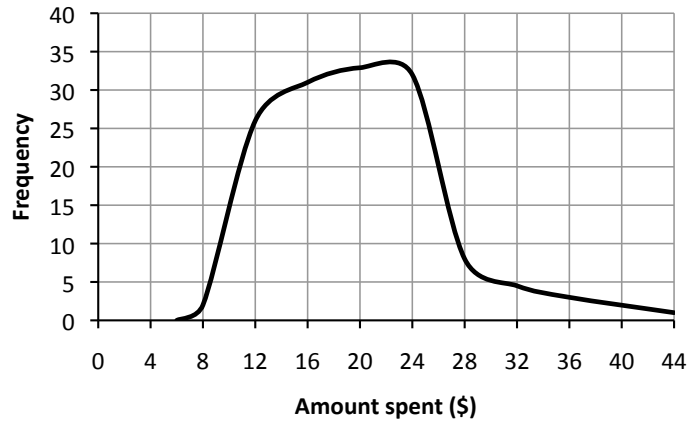

The graph shows:

A range of spending of

I know this because

The mode is

I know this because

The median is

I know this because

Very few students spend over

I know this because

Bar Graphs

- Eleven students take a test.
- The test is out of 10.
- All students scored more than 5.
- At least one student scored each mark between 6 and 10.
- The mode is 9 out of 10.

Sketch on the *Drawing Graphs* handout two bar graphs that could represent the results of the test.

- On the first graph make sure the median is equal to the mode.
- On the second graph make sure the median is different from the mode.

Mode and Median

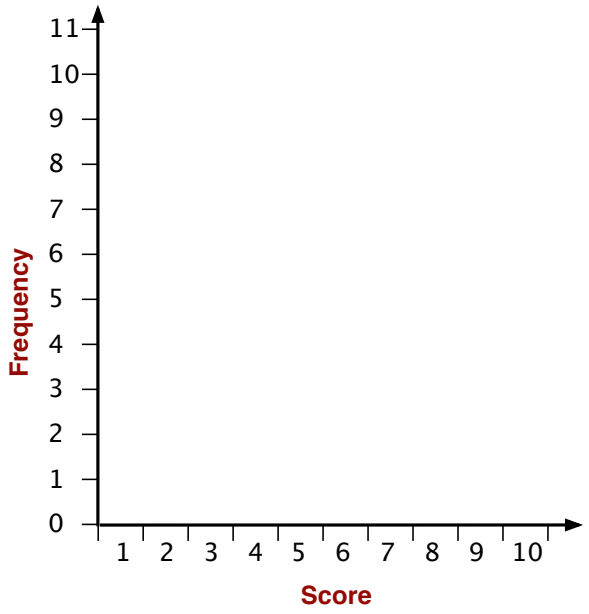
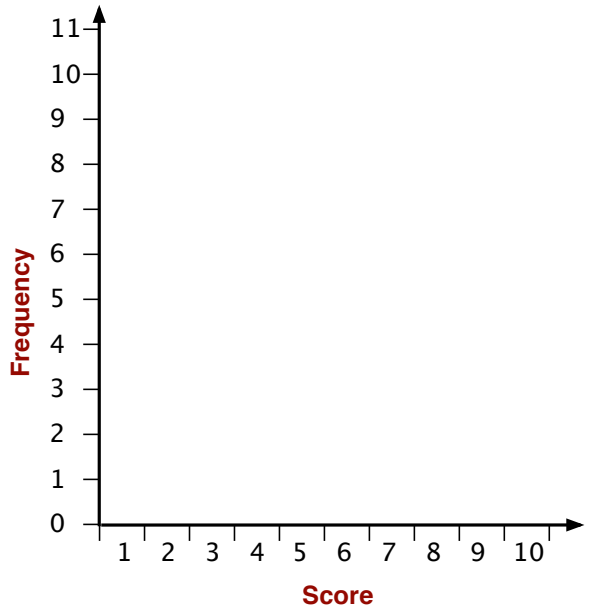

Discrete Representation

Frequency Bar Graph

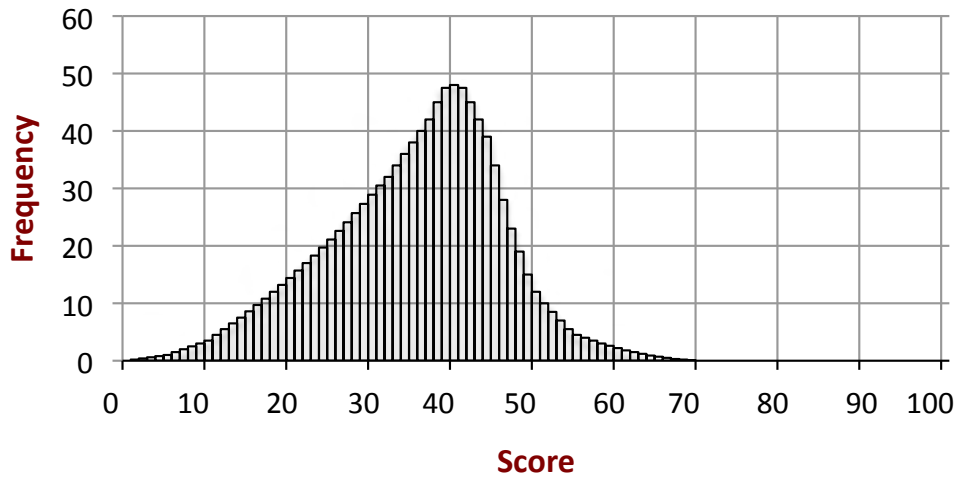

Discrete and Continuous Representations

Frequency Bar Graph

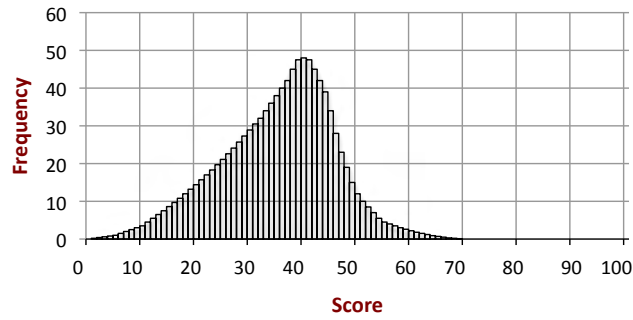

Frequency Line Graph

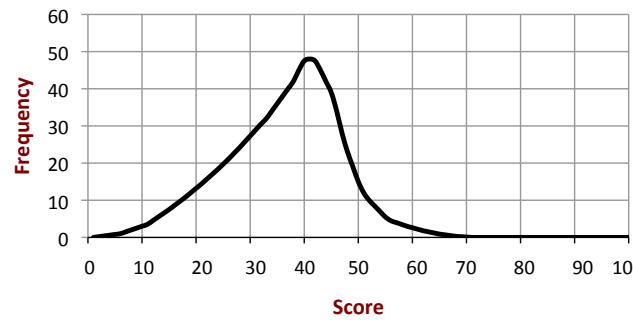

Continuous Representation

Frequency Line Graph

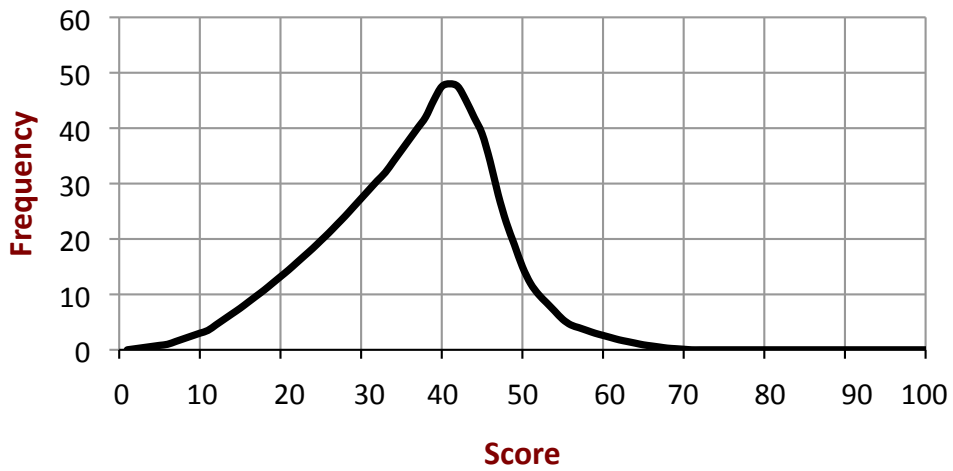

Matching Cards

1. Take turns at matching pairs of cards that you think belong together.
2. Each time you do this, explain your thinking clearly and carefully.
3. Your partner should either explain that reasoning again in his or her own words, or challenge the reasons you gave.
4. Write your reasons for the match on the poster.
5. You both need to be able to agree on and explain the placement of every card.

You may find some of ‘Word’ cards match two graphs.
This problem will be resolved as you match more cards.
Be prepared to change your mind about the matches.

Sharing Posters

1. If you are staying at your desk, be ready to explain the reasons for your group's matches.
2. If you are visiting another group:
 - Copy your matches onto a piece of paper.
 - Go to another group's desk and check to see which matches are different from your own.
3. If there are differences, ask for an explanation. If you still don't agree, explain your own thinking.
4. When you return to your own desk, you need to consider as a group whether to make any changes to your poster

Card Set: Frequency Graphs

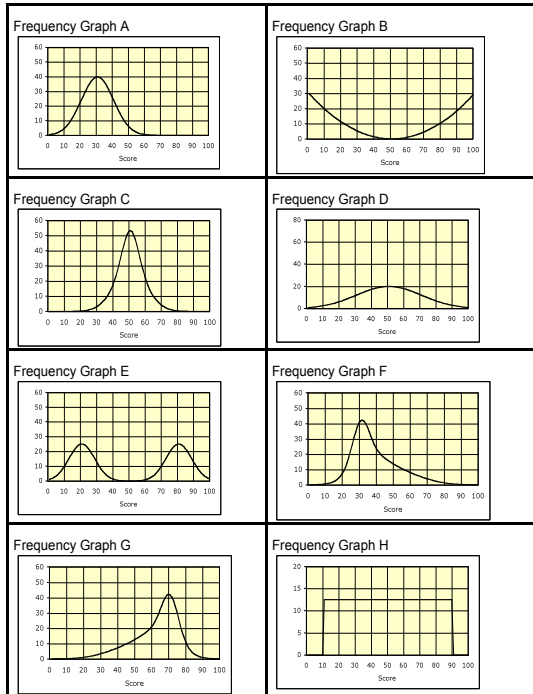

Card Set: Interpretations

1. This was the sort of test where you could either do everything or you couldn't get started.	2. This test did not sort out the stronger students from the weaker ones. They all got similar scores.
3. Two groups of students took the test. One group had studied the work for two years. The other group had only just begun.	4. This test resulted in a huge range of scores. Everyone could do something but nobody could do it all.
5. In this test, the median score was greater than the mode score.	6. In this test, the median score was smaller than the mode score.
7. In this test, the median and the mode scores were the same. There was a very big range of scores.	8. This test was much too difficult for most people.

Mathematics Assessment Project
CLASSROOM CHALLENGES

This lesson was designed and developed by the
Shell Center Team
at the
University of Nottingham

Malcolm Swan, Nichola Clarke, Clare Dawson, Sheila Evans
with
Hugh Burkhardt, Rita Crust, Andy Noyes, and Daniel Pead

It was refined on the basis of reports from teams of observers led by
David Foster, Mary Bouck, and Diane Schaefer
based on their observation of trials in US classrooms
along with comments from teachers and other users.

This project was conceived and directed for
MARS: Mathematics Assessment Resource Service
by

Alan Schoenfeld, Hugh Burkhardt, Daniel Pead, and Malcolm Swan
and based at the University of California, Berkeley

We are grateful to the many teachers, in the UK and the US, who trialed earlier versions
of these materials in their classrooms, to their students, and to
Judith Mills, Carol Hill, and Alvaro Villanueva who contributed to the design.

This development would not have been possible without the support of

Bill & Melinda Gates Foundation

We are particularly grateful to
Carina Wong, Melissa Chabran, and Jamie McKee

© 2012 MARS, Shell Center, University of Nottingham
This material may be reproduced and distributed, without modification, for non-commercial purposes,
under the Creative Commons License detailed at <http://creativecommons.org/licenses/by-nc-nd/3.0/>
All other rights reserved.

Please contact map.info@mathshell.org if this license does not meet your needs.

Summarizing and Interpreting Statistical Data

Lesson 6 of 8

The Shape of Quantitative Data

Description:

Students further explore the shape of the distribution of values of one quantitative variable, gaining a deeper understanding of what features of the shape the mean, median, and standard deviation capture. Students learn how to see and compare differences in these values from histograms as well as interpret these values in context.

Georgia Standards of Excellence Addressed:

- MGSE9-12.S.ID.1: Represent data with plots on the real number line (dot plots, histograms, and box plots).
- MGSE9-12.S.ID.2: Use statistics appropriate to the shape of the data distribution to compare center (median, mean) and spread (interquartile range, mean absolute deviation, standard deviation) of two or more different data sets.
- MGSE9-12.S.ID.3: Interpret differences in shape, center, and spread in the context of the data sets, accounting for possible effects of extreme data points (outliers).

Standard(s) for Mathematical Practice Emphasized:

- SMP 2: Reason abstractly and quantitatively.
- SMP 4: Model with mathematics.
- SMP 7: Look for and make use of structure.

Sequence of
Instruction

Activities Checklist

Engage



Start by refreshing students on the concept of identifying the median from histograms and frequency graphs covered in the previous class. Project the slide and ask students to consider the following question. Students should have a paper copy to work with since they will want to mark up the histograms. Instruct students to first answer questions one through four. The class will look at the rest of the questions after we have had a chance to share answers to the first four questions.

INCLUDED IN THE STUDENT MANUAL

Task #12: High Temperatures

The high temperature for each day in 2013 is displayed for three different cities on each of the three histograms below.

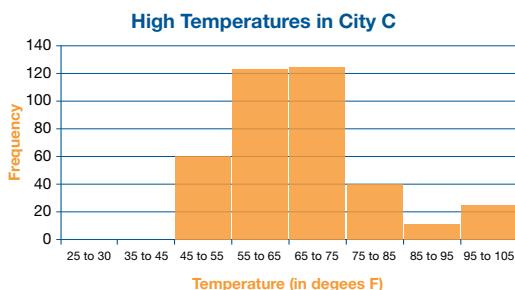
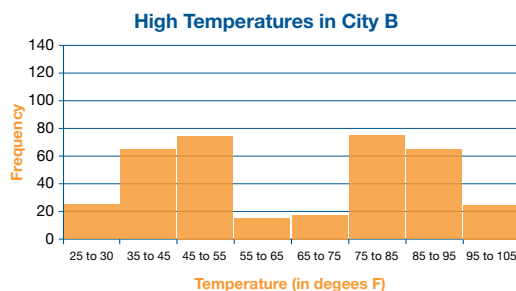
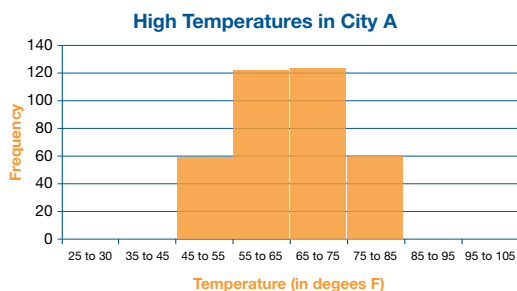

1. How many values are being displayed in each histogram?
2. Explain in this context what it means that city A has a histogram where the height of the bar over the range 45 to 55 is 60?
3. Which city had the most days with a high less than 32 degrees F?
4. Which city had the most days over 90 degrees F?
5. Approximate the median in each of three graphs. Explain how you determined your answer.
6. If the three graphs represent the high temperature for all 365 days in 2013 in three different cities, write a sentence summarizing the weather of each city in 2013. Which city would you prefer to live in?
7. Which city had the greatest mean high temperature in 2013? How did you determine your answer?
8. Which city has the smallest mean?

Possible Solution:

1. 365 values. One value for each day of the year in 2013.
2. City A had 60 days in 2013 where the high temperature was between 45 and 55 degrees F.
3. City B.
4. City B.

Solutions to questions five and eight appear below.

After students have thought individually about these questions, call on students to share their answers. You want to be sure no students are falling behind, unable to make

any sense of how to read a histogram. Remind students the horizontal axes measures the value of the quantitative variable (the temperature), and the vertical axes counts how many cases (days in 2013) fall in that bin range.

Students will be familiar with how to compute an average. Now define the mean.

The mean of a set of n values of a quantitative variable is given by:

$$\frac{X_1+X_2+X_3+\dots+X_n}{n}$$

To help illustrate how the mean captures a different essence of center, present the class with the following two datasets:

- A. 12, 8, 16, 24, 25.
- B. 12, 8, 16, 74, 25.

Ask each student to compare the mean and median of each dataset. What do they notice?

Possible Solution:

- A. Mean = 17 and median = 16.
- B. Mean = 27 and median = 16.

Commentary for the Teacher:

The big point here is that the median is resistant to outliers while the mean is more sensitive to outliers. The mean is pulled in the direction of outliers.

Students should notice the medians of A and B are the same but the means are different. The only difference in the two sets is A has a 24 while B has a 74. Changing the 24 to 74 does not affect the median since both 24 and 74 are larger than all but one value in each collection of values. The value 74 is called an outlier. The median is resistant to outliers, implying making a larger number even larger does not affect where the midpoint of all of the values is located. Same for making a small number even smaller.

Now tell students the **median** high temperature of each city was 65 degrees F in 2013.

Explore



After students have arranged themselves in pairs, ask the class to look back at the sheet (or slide) of the temperature data from the three cities. Working in pairs, have students think and discuss answers to the remaining questions.

Possible Solution:

- 5. The median temperature of cities appears to be 65 degrees F since exactly half of all values (the area of the bars) sits on each side of 65 degrees F in each histogram.
- 6. City A's temperature does not vary much. Well over half the days had a high temperature between 55 and 75 degrees F, a range of only 20 degrees F. City B has very strange weather indeed. Residents of this city had an interesting year in 2013. Of these cities, B had the most days over 90 degrees F and the most days less than 32 degrees F. Almost no days had a mild temperature. City C had very similar weather to A in 2013, but C had 10 days where the high was between 85 and 95 degrees F

and another 10 days where the high reached over 95 degrees F. City A had no days where the high temperature reached over 85 degrees F. Most people would prefer to live in city C.

7. City C. Cities A and B had the same spread of values above and below the median. The histograms for A and B are symmetric, so mean and median should be about the same. City C had outliers. As we saw in the previous activity, outliers will pull the mean up but will not affect the median. City C will therefore have the greatest mean.
8. Both A and B have the same mean temperature.

Commentary *for the Teacher:*

Point out that in city C, we could determine distribution of the temperature is **skewed to the right** since the mean is bigger than the median (it must have been pulled up by an outlier on the upper tail). We could also determine the distribution of the temperature is approximately symmetric in cities A and B since the mean temperature is equal to the median temperature in these cities.

Before moving on, ask the students the following:

“Cities A and B have the same mean and median as each other, but do they look the same?”

Students should comment on the different shapes, one appears bell-shaped, the other bimodal (not suggesting you use this terminology, rather describe that feature informally). Thus, it would be useful to have another measure, the spread, when it comes to summarizing the shape of the distribution of values of a single quantitative variable. One common way to measure the spread of values of a single quantitative variable is with the standard deviation. Have students recall their original descriptions of the weather in both city A and B. They should have commented that city A has a high within five degrees of the mean temperature of 74 degrees F. While city B had virtually no days with a high of 74. City B had a lot of really warm days that balanced out with a lot of really cold days. So the weather in City B varied much more than the weather in City A. The larger the spread in the values, the larger the standard deviation.

Explanation

Project slide one (shown on the next page); review the previous discussion and lead students to verify the key observations illustrated on the slide, namely the implications the shape of a distribution has on the relation between measurements of center. When the distribution has a tail to the left, that means it has outliers on the low end, and these outliers will affect the value of the mean but not have an effect on the median. We say such a distribution is skewed to the left. It’s the opposite story when the histogram has a tail to the right.

Refer back to the previous example with the temperatures of the three cities. Both cities A and B had mean equal to median, but they still have very different shape corresponding to their very different weather patterns. Now project slide two (see below).

In slide two, explain how you can almost feel the values getting pulled more and more away from the center as the histograms go left to right. The larger the spread of the values, the larger the standard deviation.

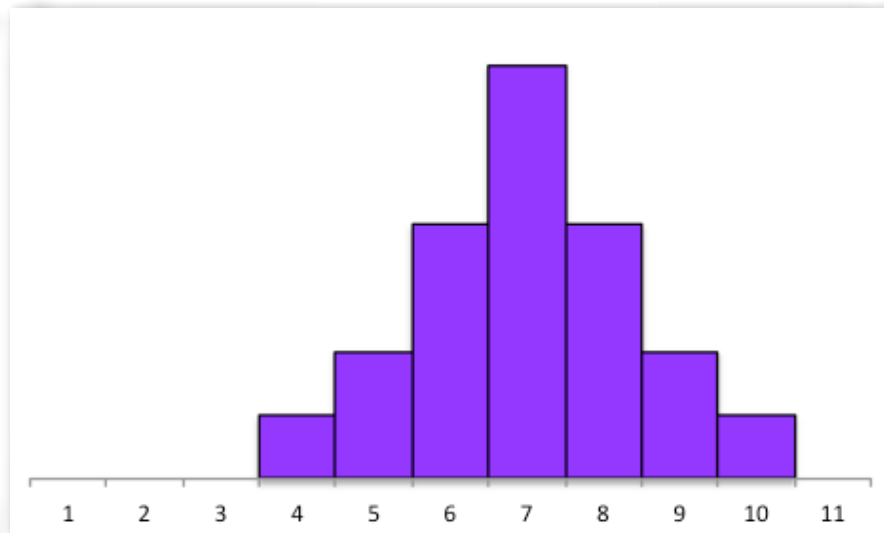

Symmetric: Mean = Median

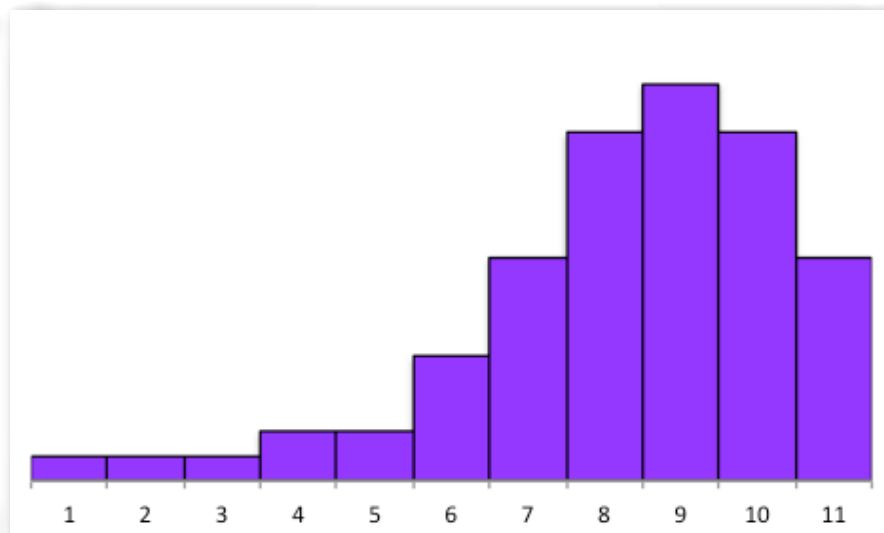

Skewed to the left: Tail pulls the mean down. Mean < Median

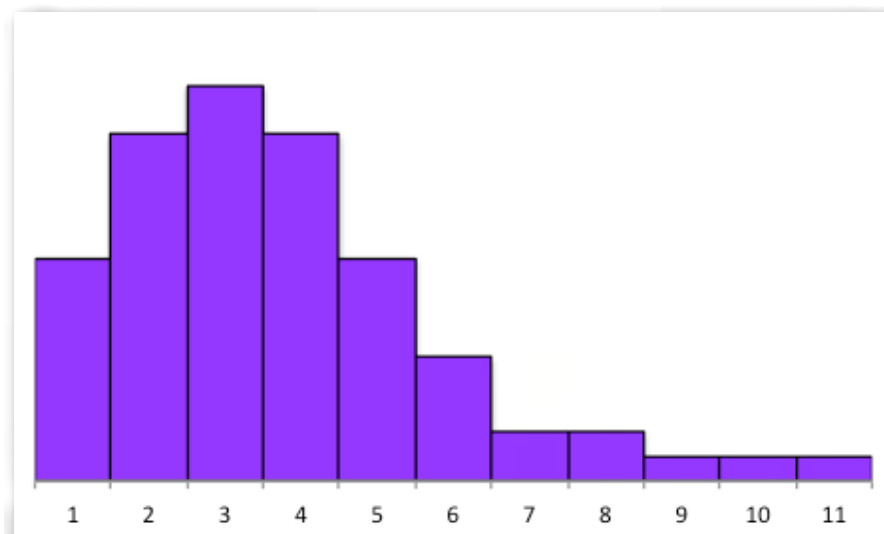

Skewed to the right: Tail pulls the mean up. Mean > Median

The **standard deviation** is a measure of the **spread** of the data. The more spread out the values are, the larger the standard deviation.

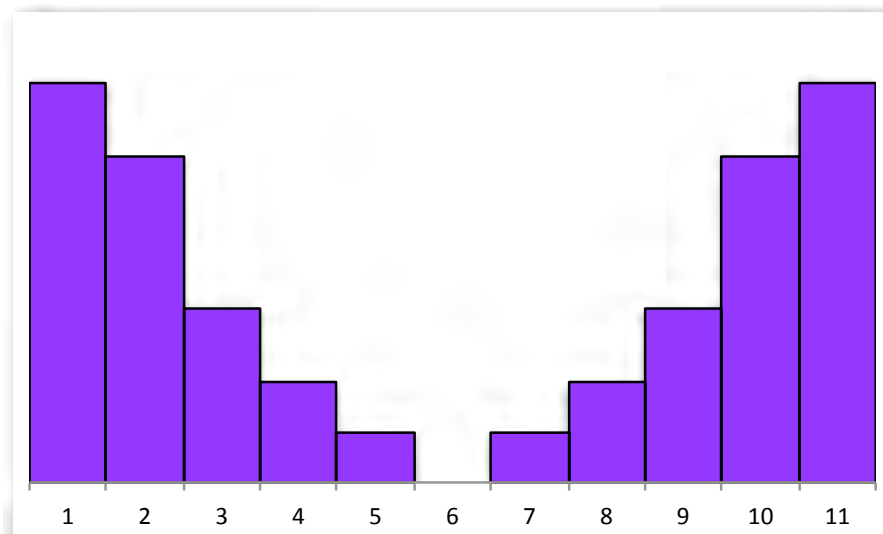
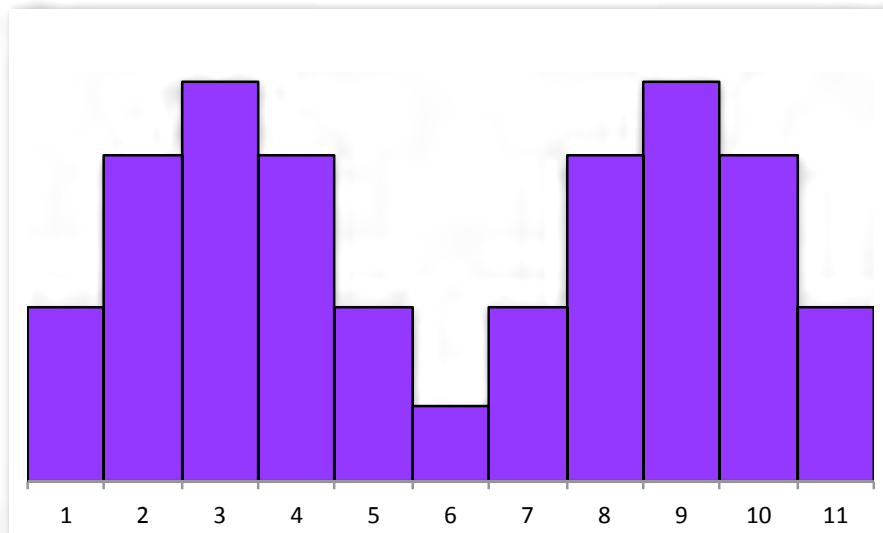
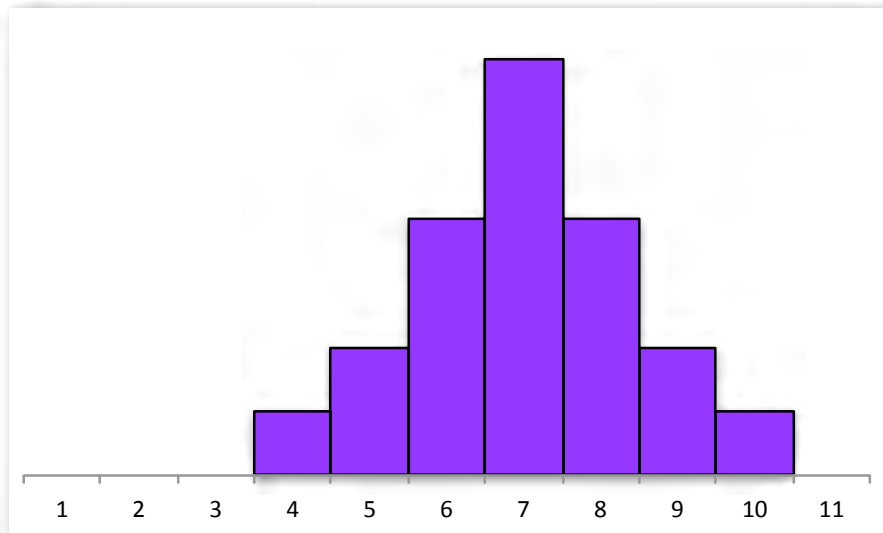

Practice Together in Small Groups/Individually



INCLUDED IN THE STUDENT MANUAL

Task #13: Insuring a Car

The histogram below shows the distribution in the values of the average cost of insuring a car in each of the fifty states and the District of Columbia (data found at <http://www.census.gov/hhes/www/hlthins/data/historical/index.html>).

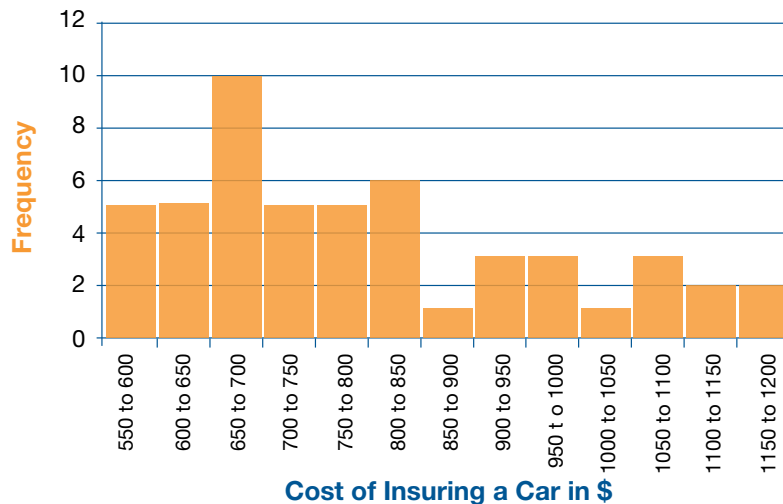

Approximate the median of this distribution. Round your answer to one decimal place and use the appropriate notation when expressing your answer.

Will the mean cost of insuring a car be more or less than the median? How can you tell?

Commentary for the Teacher:

A common question is, “If the cost of insuring a car in a state is exactly \$600, which bin does it go in?” This is a very good question. You can tell students that in this histogram, the bins include the value on the left and exclude the values on right. So \$600 is excluded from the first bin and included in the second bin. A state that has a cost of exactly \$600 would be grouped into the \$600 to \$650 bin.

Students may want to be more precise than the histogram allows. For example, you only know five states had a cost between \$550 and \$600. You do not know whether all five values are \$550 or whether all five are \$599, or any other possibility. Thus, when the median is approximated as \$750, students may want to know what range of values would be appropriate for the median. You know in this case the median must be \$750 or more since you know exactly 25 values are less than \$750. The median is the 26th greatest value in the dataset, which sits somewhere in the \$750 to \$800 bin. So, any answer greater than or equal to \$750 and strictly less than \$800 could possibly be the median. Any other value could not.

Possible Solution:

There are a total of 51 values plotted in the histogram above. The median is the value such that 25 values are less than it and 25 values are greater than. There are five states where the cost is between \$550 to \$600. There are five more states where the cost is between \$600 and \$650. Altogether, 10 states have costs less than \$650 and 41 states

have costs greater than \$650. The median must be greater than \$650. Moving out to the next bin, there are a total of $5+5+10=20$ states where the cost is less than \$700. The median must be higher still. Moving out one more bin, adding the heights of the first four bins, you see there are a total of $5+5+10+5=25$ states where the cost is less than \$750. The median is approximately \$750. The mean cost will be larger than the median because the shape of the distribution is skewed to the right. The outliers on the right pull the value of the mean greater than the median.

INCLUDED IN THE STUDENT MANUAL

Task #14: Which has a Greater Standard Deviation?

Which do you expect to have a greater standard deviation: the distribution of the number of siblings of all students in our class or the distribution of the number of Facebook friends of all students in our class? Explain how you determined your answer.

Possible Solution:

The distribution of the number of Facebook friends should have a much bigger spread in the size of the values. It is possible some people do not use Facebook and have no friends. Some people have an incredibly large number of friends on Facebook. The distribution of values is quite large. The number of siblings should have a lot less variation. Nearly everyone would have somewhere between zero and two siblings. Therefore, the distribution of the number of Facebook friends should have a much bigger standard deviation.

Closing Activity

Place students into groups of three or four students and have them begin working on the task below. You could construct and develop the questions on the handout further if you feel the students will benefit from a deeper investigation of these concepts.

INCLUDED IN THE STUDENT MANUAL

Task #15: The Shape and Center of Data: Quiz Scores

A college statistics professor gave the same quiz (scored out of a total of 10 points) to his students over the past seven years. The distribution of the scores are displayed in the histograms labeled (i)-(vi) below.

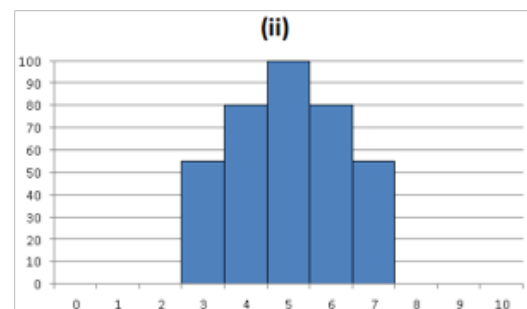
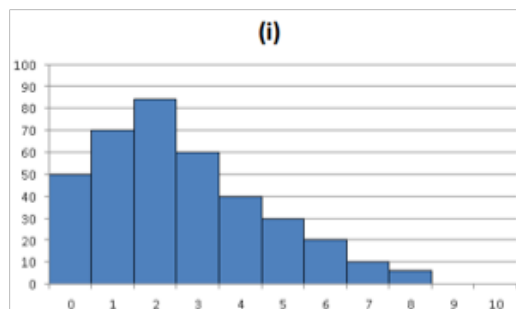

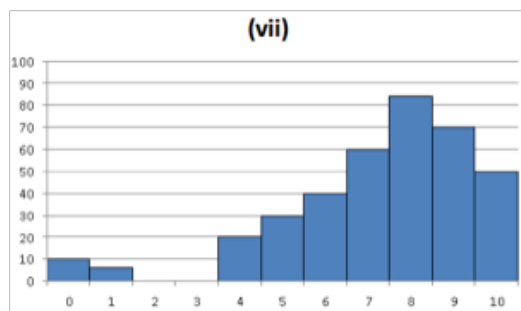
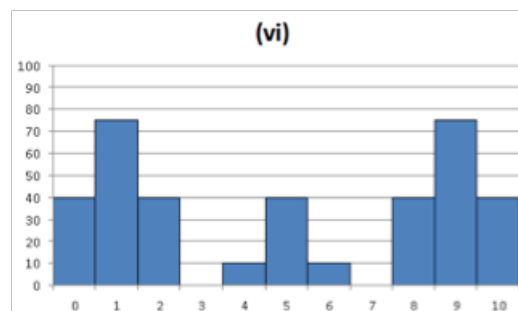
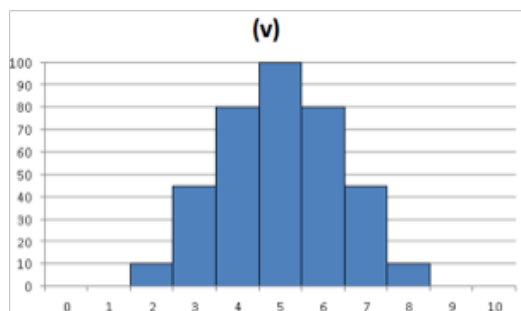
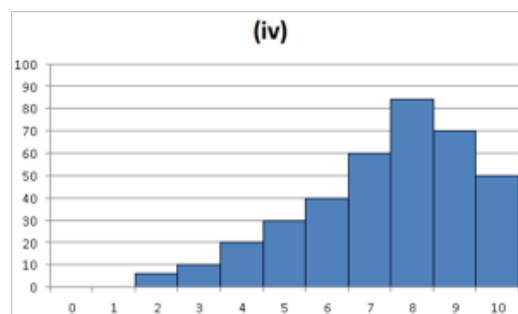
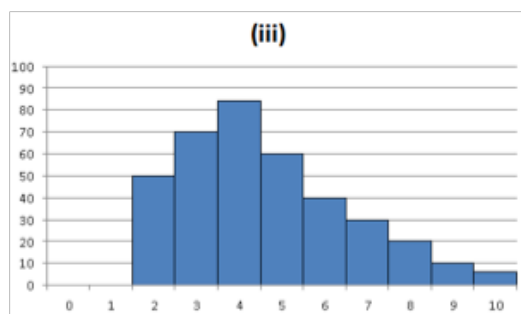

1. Which histogram(s) have a mean which is greater than its median? What does this imply about the distribution of the students' scores?
2. Which histogram(s) have a mean which is equal to its median? What does this imply about the distribution of the students' scores?
3. Which histogram appears to have the smallest mean? Interpret what this means in the context of quiz performance.
4. Which histogram appears to have the largest mean? Interpret what this means in the context of quiz performance.
5. Which histogram appears to have the largest standard deviation? Interpret what this means in the context of quiz performance.
6. Which histogram appears to have the smallest standard deviation? Interpret what this means in the context of quiz performance.

Commentary for the Teacher:

Students are likely to struggle, so make sure they are supporting each other if there is some confusion. A common confusion arises in questions three and four. For example, a student might assume “the year corresponding to histogram (iv) has a tail to the left, and I know its mean will be less than its median. Therefore, the histogram (iv) has a very small mean.”

The misconception here is that histogram (iv) has a median which is extremely big since most of the values on that data set are above eight. Just because the mean is less than this relatively speaking large value, does not imply the mean must be small. Histogram (iv) actually has the highest mean since that class scored the best.

Possible Solutions:

1. (i) and (ii). These years had most students cluster on the lower spectrum of grades, but there were a few students who did much better than the rest of the class, and these students would pull up the average.
2. (ii), (v), and (vi). These histograms are all symmetric. The students who did well and poorly balance each other out, and the mean should be very close in value to the median.
3. (i). Almost all students scored zero, one or two, and no students scored above an eight.
4. (iv). Many students scored eight or above, and no students scored zero or one.
5. (vi). The students in that year did either really well (eight, nine or 10) or really poorly (zero, one or two). There were very few students in between.
6. (ii). A large majority of the class scored four, five and six. There was very little spread in the quiz scores.

Independent Practice:

If you ran out of time before completing the closing activity, instruct students to complete the task before the next lesson.

Resources/Instructional Materials Needed:

Computer projector to display engage activity slide as well as histogram slides one and two.

Notes

After the previous formative assessment lesson, students should now be familiar with displaying one quantitative variable using histograms and frequency graphs. Students should also be able to identify and interpret the median value. This lesson begins by refreshing students on the concepts of mean and standard deviation, since in practice, students are rarely going to need to calculate a standard deviation of any dataset (large or small). There are plenty of software and internet options available to compute descriptive statistics. The intention of this lesson is to get students comfortable discussing, seeing and understanding what characteristics of the data these statistics measure. Instructors are welcome to have students gain experience doing hands on calculations. We suggest using small datasets or using technology that students are likely to find useful in other contexts as well (e.g., Excel or graphing calculators). As it stands, no technology is required for this lesson.

Summarizing and Interpreting Statistical Data

Lesson 7 of 8

Analyzing the Strength of an Association

Description:

In this lesson students think about relationships between various pairs of quantitative variables taken from a large dataset on specifications of many different car models. Students will first use intuition, followed by informally assessing trends in a scatterplot, and finally by describing the strength of an association using a correlation coefficient.

Georgia Standards of Excellence Addressed:

- MGSE9-12.S.ID.6: Represent data on two quantitative variables on a scatter plot, and describe how the variables are related.
- MGSE9-12.S.ID.8: Compute (using technology) and interpret the correlation coefficient “ r ” of a linear fit. (For instance, by looking at a scatterplot, students should be able to tell if the correlation coefficient is positive or negative and give a reasonable estimate of the “ r ” value.) After calculating the line of best fit using technology, students should be able to describe how strong the goodness of fit of the regression is, using “ r ”.

Standard(s) for Mathematical Practice Emphasized:

- SMP 2: Reason abstractly and quantitatively.
- SMP 3: Construct viable arguments and critique the reasoning of others.
- SMP 4: Model with mathematics.
- SMP 5: Use appropriate tools strategically.
- SMP 6: Attend to precision.

Sequence of
Instruction

Activities Checklist

Engage



Write (or project) the following definitions at the front of the room for all students to see:

Two variables are **associated** or **correlated** if the values of one variable tend to be related to the values of the other variable. When studying the relationship between two quantitative variables, remember:

- If an increase in the value of the explanatory variable tends to lead to an increase in the response variable, we say there is a **positive association**.
- If an increase in the value of the explanatory variable tends to lead to a decrease in the response variable, we say there is a **negative association**.
- If there is no relation between the value of the explanatory variable and the value of the response variable, then we say there is **no association** between the two variables.

Pass out the Investigating Correlation with Cars Data handout.

Assign students to work in groups of two or three. Have them first consider question one on the activity sheet—the initial guesses. Have students take turns sharing their thoughts for each pair. Person one says what he/she thinks about the pair in (a), and if other members of the group disagree, they discuss until a consensus is met. Person two then shares his/her answer for pair (b), and so on. For example, student one says their answers for the first pair and explains his/her reasoning to his/her partner. Then, the other student shares his/her answer for the next pair, supporting his/her answer. If they disagree, have them try to come to a consensus.

After groups have finished the discussion, mark (a) through (f) on the board and call on groups to share their answers. Mark the consensus answer beside each corresponding letter. For example, (a) Moderate Negative, (b) Moderate Positive, and so on.

Commentary *for the Teacher:*

Be sure you note that the variable ‘acceleration’ measures the time it takes to reach 60 mph. Therefore, a large value of acceleration means the car has poor acceleration. This might confuse the direction of the association in (e).

Possible Solution:

- (a) Moderate Negative. As the weight of a car increases, it tends to become less fuel efficient.
- (b) Moderate Positive. Bigger cars tend to have larger fuel tanks.
- (c) No association. There is no reason to suspect the page number has any relation to the fuel capacity.
- (d) Moderate or Weak Negative. The heavier the cars tend to travel slower.
- (e) Strong Positive. The less time it takes to accelerate to 60 mph, the less time it takes to travel $\frac{1}{4}$ mile.
- (f) Weak Positive. Cars that are slow tend to get worse gas mileage.

INCLUDED IN THE STUDENT MANUAL

Task #16: Investigating Correlations with Cars Data

The Consumer Reports 1999 New Car Buying Guide contains lots of information for a large number of new (at that time) car models. Some of the data for 109 of these cars has been extracted. This activity will focus on the relationships among several of these variables including:

- Weight** = Weight of the car (in pounds)
- CityMPG** = EPA’s estimated miles per gallon for city driving
- FuelCap** = Size of the gas tank (in gallons)
- QtrMile** = Time (in seconds) to go 1/4 mile from a standing start
- Acc060** = Time (in seconds) to accelerate from zero to 60 mph
- PageNum** = Page number on which the car appears in the buying guide

1. Initial guesses (BEFORE looking at the data)

Consider the relationship you would expect to see between each the following pairs of variables for the car data. Place the letter for each pair on the chart below to indicate your guess as to the direction (negative, neutral or positive) and strength of the association between the two variables.

Note: You may have more than one letter at approximately the same spot.

- (a) Weight vs. CityMPG
- (b) Weight vs. FuelCap
- (c) PageNum vs. FuelCap
- (d) Weight vs. QtrMile
- (e) Acc060 vs. QtrMile
- (f) CityMPG vs. QtrMile

Strong	Moderate	Weak	No	Weak	Moderate	Strong
Negative	Negative	Negative	Association	Positive	Positive	Positive

2. Associations from scatterplots

- Examine scatterplots for the various pairs of car variables listed above.
- Revise your estimates on the direction and strength of each association in the chart below.

Strong	Moderate	Weak	No	Weak	Moderate	Strong
Negative	Negative	Negative	Association	Positive	Positive	Positive

- How did you do with your initial guesses?

INCLUDED IN THE STUDENT MANUAL

3. Correlations for each pair

The correlation coefficient, denoted by r , is a measure of the strength of the linear association between two variables. Use the values shown in the slides to record the correlation for each of the six pairs of variables, (a) – (f).

	correlation		correlation
(a) Weight vs. CityMPG		(d) Weight vs. QtrMile	
(b) Weight vs. FuelCap		(e) Acc060 vs. QtrMile	
(c) PageNum vs. FuelCap		(f) CityMPG vs. QtrMile	

4. Properties of correlation

Based on your observations of the scatterplots and computed correlations, write down at least three properties that would appear to be true about a sample correlation and its interpretation.

(1)

(2)

(3)

Explore



After discussion is complete for the first question, project the slide that defines a scatterplot. Be sure to emphasize that we plot the explanatory variable on the “x” (or horizontal) axis and the response on the “y” (or vertical) axis.

Scatterplots: Dsplaying Two Quantitative Variables

A **scatterplot** is a graph of a relationship between two quantitative variables. Each case corresponds to a point in the scatterplot. Values of the explanatory variables are read from the horizontal axis while values of the response variable are read from the vertical axis.

Next project the slide of the six scatterplots.

Car And Driver

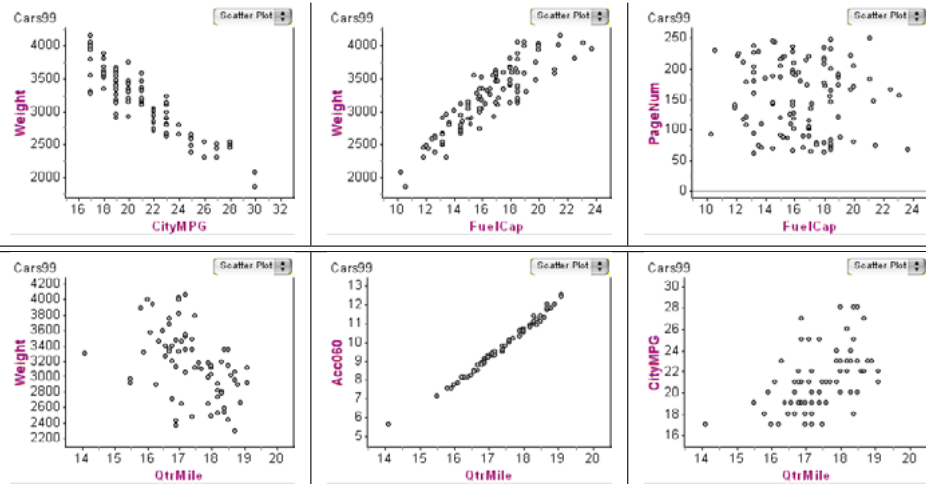

Explain that pairs (a)-(c) are across the top row and pairs (d)-(f) are across the bottom row. Also, point out based on the axes which variable is the explanatory variable and which is the response. After students are clear on how to read the scatterplots, have them answer the second question on the Investigating Correlation with Cars Data handout. Again, have person one take a one pair, person two take the next pair and continue taking turns within each group. Be sure you press the students to explain their reasoning, not just provide an answer.

After groups have finished their discussions, go back to the answers they came up with for question one, and ask if they want to revise any of their answers based on the most recent discussion. In the group and class discussion, students should be noticing that when dots tend to go up as you go to the right, there is positive association (and positive slope). When dots tend to go down as you go to the right, there is positive association (and negative slope). When the dots appear like a disorganized cloud of points, there is little evidence to support any association.

Ask students, “How can you visually determine the strength of a correlation?” Students should probably comment in (e) they are almost perfectly in line, thus the correlation should be really strong, as suspected. Wouldn’t it be nice to have a more systemic way to measure the strength of the association?

Finally, project the slide that now shows the scatterplots along with the correlation coefficient. Have students answer the third question on the Investigating Correlation with Cars Data sheet. After students have had time to discuss, call on volunteers to share some their answers.

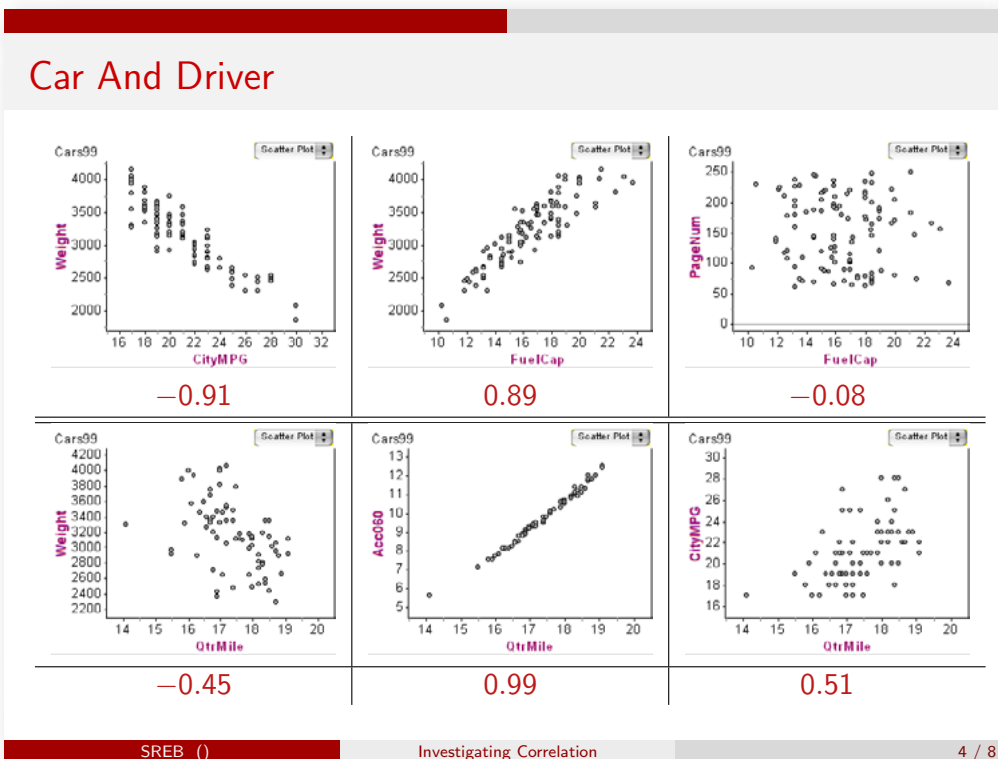

Explanation

Project the slide titled Properties of Correlation to summarize students' findings.

Properties of the Correlation

The **correlation coefficient** is a measure of the strength and direction of **linear** association between **two quantitative variables**.

SREB () Investigating Correlation 5 / 8

It is very important to stress that scatterplots and correlation coefficients are good ways to measure whether there is a correlation between two variables. However, correlation coefficients cannot be used to determine whether the correlation is causal. Two variables can be very strongly correlated but not have a causal relationship.

Practice Together in Small Groups/Individually



If you have access to project the internet, open the following website and project on the front board: <http://istics.net/Correlations/>

Depending on your policy and resources, you can tell students to visit the website themselves using a laptop, tablet or smartphone. Below is a screenshot. If you do not have access to a computer during class, you should take some screenshots in advance and pass the screenshots around to your students. Have several good examples ready to go in that case.

Guessing Correlations

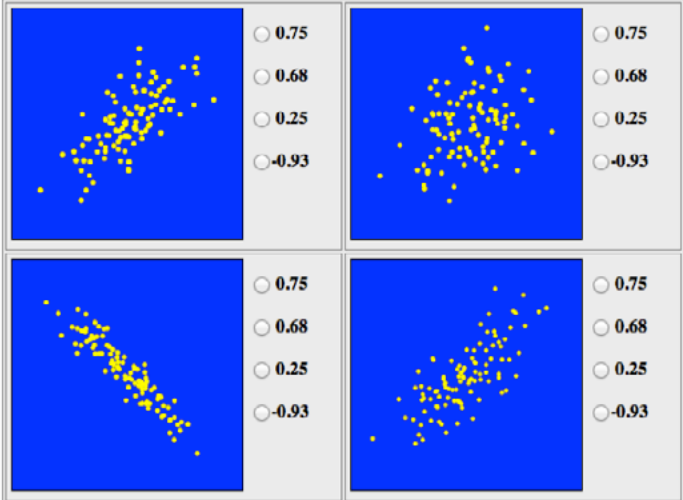

Match the correlations with the scatter plots.

This is a nice activity to hone in on understanding what the correlation coefficient measures. You can call on students to see who can get the most correct in a row. If students have their own devices, just let them explore the website themselves.

Evaluate Understanding



Try a couple of examples from the website together and make sure everybody is clear on the concept of correlation coefficients.

Pick a couple of pairs of quantitative variables, possibly some of the data you collected in the survey at the start of this unit. Ask students, “Do you believe the correlation coefficient for each pair will be positive, negative, or zero? Which correlation coefficient will be most positive? Most negative?”

Choose several pairs that have various signs and strengths. Certainly feel encouraged to use your own examples that will be of particular interest to your students (and you may have collected data). For example:

1. The number of daily text messages sent and the number of hours studying each week.
2. A person’s height (in inches) and foot length (in inches).
3. Number of hours spent at work and the amount of TV watched in a week (in hours).
4. Date of birth (for example 26 born on August 26) and number of texts messages sent on a typical day.
5. Number of siblings and number of Facebook friends.

Commentary *for the Teacher:*

Be sure students are expressing ideas along the lines of when this value is increasing; expect the value of the response variable to go up/down in value.

- Students may confuse no correlation with a negative correlation. For example, “Since I don’t expect any relation to exist between date of birth and texts sent, it must be the most negative.” Be sure you correct this thinking.

- Students confuse a strong correlation as one that must be positive. For example, “Since I expect the amount of time at work and watching TV to have a very strong negative correlation. Since it is strong, I expect the correlation to be positive.” This is also a common error.

Possible Solution:

(Answers can certainly vary. There may be some disagreement about the signs. Encourage students to support their answers with thoughtful reasons.)

1. Negative.
2. Positive.
3. Negative.
4. Close to zero.
5. Positive.

Dataset two seems to have the strongest positive correlation, so its correlation coefficient would be the most positive. Dataset three seems to have the strongest negative correlation, so its correlation coefficient would be the most negative.

Closing Activity



INCLUDED IN THE STUDENT MANUAL

Task #17: Academic Achievement

Medhavi suspects that there is a relationship between the number of text messages high school students send and their academic achievement. To explore this, she asks each student in a random sample of 52 students from her school how many text messages he or she sent yesterday and what his or her grade point average (GPA) was during the most recent marking period. The data are summarized in the scatter plot of number of text messages sent versus GPA, shown below.

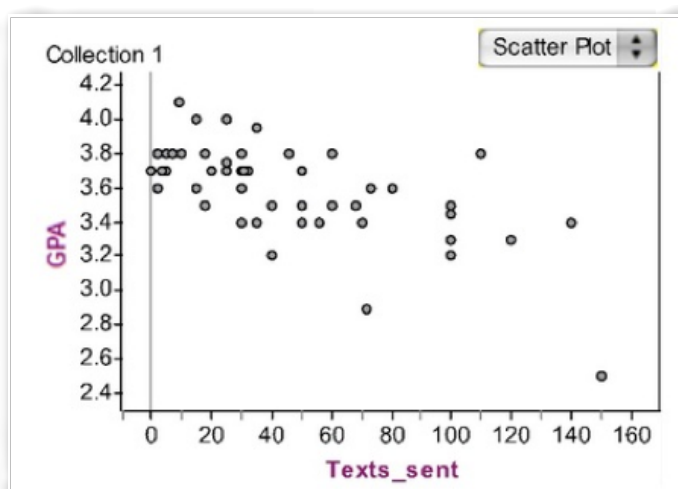

Describe the relationship between number of text messages sent and GPA. Discuss both the overall pattern and any deviations from the pattern.

(<http://www.illustrativemathematics.org/illustrations/975>)

Commentary for the Teacher:

The student should address the form of the relationship (linear, curved, etc.), direction (positive or negative), strength of the relationship between the two variables and also point out any unusual observations.

Possible Solution:

The scatter plot shows a moderate negative linear relationship between the number of texts a student sends and his or her GPA. There is one outlier that has a particularly low GPA and high number of texts sent, though it is in keeping with the overall pattern. It appears that students who send more text messages tend to have lower GPAs.

Independent Practice:

The task below will be covered in Lesson 8. Depending on the comfort level of your students, you can assign this as an optional (or required) assignment to work on outside of class. You can explain that the next class will cover linear regression, so if stuck, you will clear this up in the next class.

INCLUDED IN THE STUDENT MANUAL

Task #17: Academic Achievement #2

Medhavi suspects that there is a relationship between the number of text messages high school students send and their academic achievement. To explore this, she asks a random sample of 52 students at her school how many text messages they sent yesterday and what their grade point average (GPA) was during the most recent marking period. Her data are summarized in the scatter plot below. The least squares regression line is also shown.

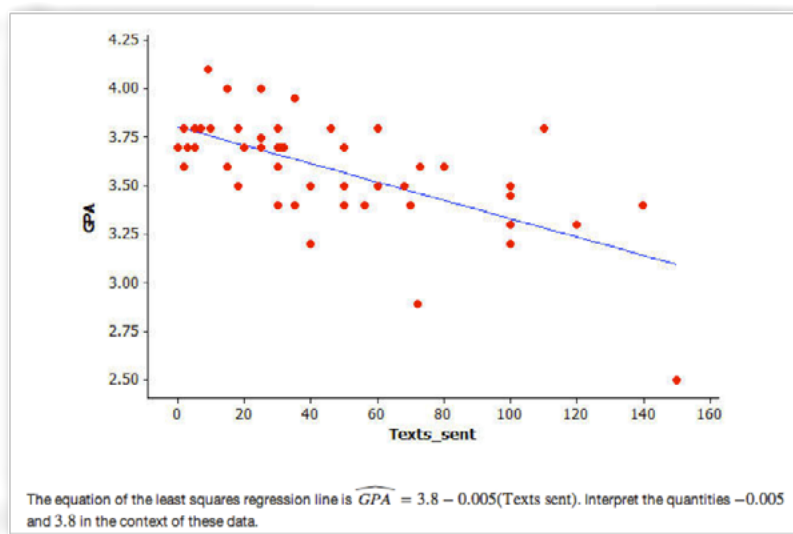

(<http://www.illustrativemathematics.org/illustrations/1028>)

Commentary for the Teacher:

The purpose of this task is to assess ability to interpret the slope and intercept of the least squares regression line in context. There are two common errors that students make when interpreting the slope. Students may not make it clear that the slope is the

Summarizing and Interpreting Statistical Data

Lesson 8 of 8

Interpreting the Line of Best Fit

Description:

Students further analyze the relationship between two quantitative variables using scatterplots. In this lesson, students informally fit their own line of best fit. After constructing a linear model depicting an association between two variables, students use the model to make predictions and interpret the meaning of the slope and the intercept of a linear model in the context of the data.

Georgia Standards of Excellence Addressed:

- MGSE9-12.S.ID.6: Represent data on two quantitative variables on a scatter plot, and describe how the variables are related.
- MGSE9-12.S.ID.6a: Decide which type of function is most appropriate by observing graphed data, charted data, or by analysis of context. Emphasize linear, quadratic and exponential models.
- MGSE9-12.S.ID.6c: Using given or collected bivariate data, fit a linear function for a scatter plot that suggests a linear association.
- MGSE9-12.S.ID.7: Interpret the slope (rate of change) and the intercept (constant term) of a linear model in the context of the data..

Standard(s) for Mathematical Practice Emphasized:

- SMP 2: Reason abstractly and quantitatively.
- SMP 4: Model with mathematics.

Sequence of
Instruction

Activities Checklist

Engage

MATH
4
PRACTICE

Divide the class into three groups. Each group will gather data on three length measurements related to the hand and arm, as follows.

Each member of the team will provide three data values based on length measurements of the hand and arm. These measurements should be given to the nearest quarter or eighth of an inch, according to the precision allowed by the measuring tape. Prior to recording the measurements, the student should hold their hand with the palm facing down, and should try to hold their hand flat while extending the fingers so that the tips of the little finger and the thumb are as far apart as possible. Then, students are to measure the following lengths:

- i) The distance from the tip of the little finger to the tip of the thumb.
- ii) If the hand is tipped towards the face, there is a fold at the wrist. Re-straighten the hand, then measure the distance from the tip of the middle finger to the center of the wrist fold.
- iii) Likewise, if the arm is flexed towards the face, there is a fold at the elbow. Measure the distance from the center of this fold to the center of the wrist fold.

Each team will have recorded a set of data, in inches, for each team member.

For example:

Name	Finger-to-finger	Finger-to-wrist	Wrist-to-inside-elbow
Dave	$8\frac{1}{4}$	$8\frac{3}{8}$	$10\frac{1}{2}$

After converting these measurements to decimals, the group should construct scatterplots for each of the three pairs of variables (FF,FW), (FF,WE) and (FW,WE). Three pages of handouts for recording these results are provided.

The three groups will now have a total of nine scatterplots. On the basis of these scatterplots, have each of the three groups independently determine which of the nine scatterplots displays data showing the strongest correlation and which of the nine scatterplots displays data showing the weakest correlation. Prior to performing any calculations, have each team submit their guesses with a brief written rationale for their decision.

Optional Technology Application:

Finally, for the scatterplots that are selected as having the most extreme correlation coefficients, have the groups use a calculator or computer software to determine the R-values, then comment as to whether the calculations match their guesses.

INCLUDED IN THE STUDENT MANUAL

A Show of Hands/Arm in Arm

FF	FW

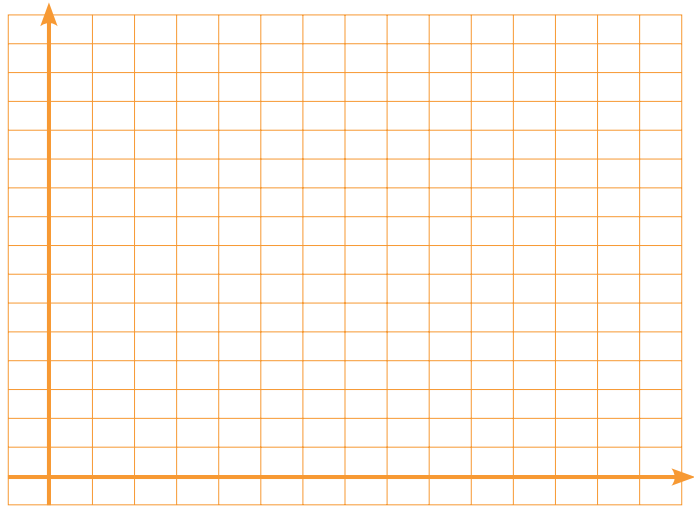

r =

FF	FW

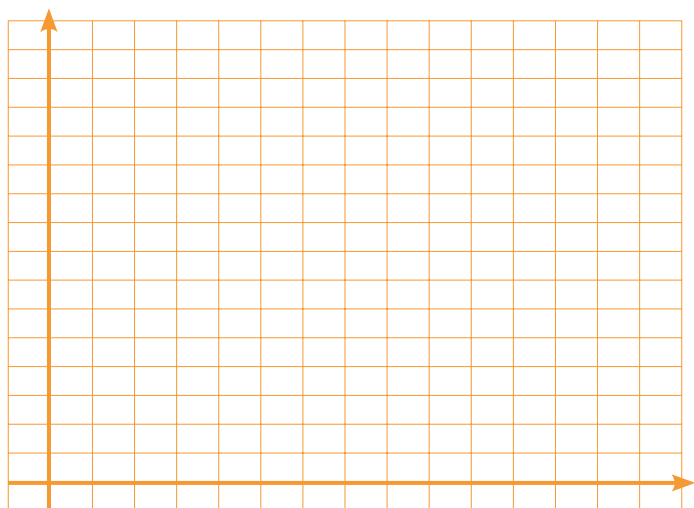

r =

Explore



In each group, have them select the scatterplot that seemed to have the strongest positive correlation. Pose the following:

“Find a formula for linear equation that best fits the model. When constructing your equation, use appropriate notation in place of the generic variables x and y . After you have a formula for this model, interpret the meaning of the slope and the intercept. Include units in your explanations, and say whether the meaning is practical or not.”

If needed, you can remind students of the general slope-intercept form of a linear equation: $y=mx+b$.

After groups have settled on a good formula, ask each to present their formula and interpretations to the class. Make sure students have chosen the correct variable for the input and output in the formula. It is possible some students struggle to recall how to find equations and interpretations for linear models. Be sure you find a confident student willing to take on the responsibility of ensuring everyone in the group understands how to construct the formula of a line.

If more than one group chose the same pair of variables to model, compare their two models. Finally, measure your own finger-to-finger length. Tell students to use the models shared to predict your other two measurements and discuss how close the predictions are.

Possible Solution:

Below is a completely made up example to illustrate the meaning of the parameters in the linear equation. Answers will vary (possibly greatly).

$$WE = 2.2(FF) - 8.4$$

The slope tells us that for each one inch increase in the finger-to-finger length, a person’s wrist-to-inside elbow length is predicted to increase by 2.2 inches.

The vertical intercept tells us that if a person’s finger-to-finger length is zero; their wrist-to-elbow length is predicted to be -8.4 inches. In this context, the vertical intercept does not make sense since it would be impossible to have a negative length.

Ms. Kelly has $FF=8.25$ inches. The model above predicts Ms. Kelly’s WE measurement will be approximately $WE=2.2(8.25)-8.4=9.75$ inches. Ms. Kelly’s actual WE measures 10.25 inches. The approximation is off by -0.5 inches.

Before presenting the Interpreting Slope and Intercept slide, make a point that the actual WE is 10.25 while the predicted WE is 9.75 in. These are typically different values, so we want to be sure we can clearly denote this distinction. One common way to denote the predicted value is putting a “hat” over the predicted value of the response variable. For example:

$$WE = 10.25 \text{ in and } \widehat{WE} = 9.75 \text{ in}$$

Therefore, we can express our formula as:

$$\widehat{WE} = 2.2(FF) - 8.4$$

Explanation

Project the Linear Regression slide.

Be sure to emphasize how helpful and necessary it is to pay attention to the units of the variables when interpreting the values of the slope and intercept.

Be sure students are mindful of the context. It is possible that the intercept or slope might not make practical sense.

Be sure students are clear on the distinction between the correlation coefficient and the slope. They share the same sign, but that is all. An association that is very strong (correlation coefficient close to 1 or -1) can have a slope that is very close to zero. A correlation coefficient which is close to zero might have a slope that is very large or even of the opposite sign.

The correlation coefficient measures the strength of the association (strong, moderate or weak). The slope measures by about how much we expect the response variable to change if the explanatory variable increases by one unit.

Practice Together in Small Groups/Individually



INCLUDED IN THE STUDENT MANUAL

Task #18: Academic Achievement #3

(Independent Practice from Lesson 7. Students may or may not have worked on this in advance.)

Medhavi suspects that there is a relationship between the number of text messages high school students send and their academic achievement. To explore this, she asks a random sample of 52 students at her school how many text messages they sent yesterday and what their grade point average (GPA) was during the most recent marking period. Her data are summarized in the scatter plot below. The least squares regression line is also shown.

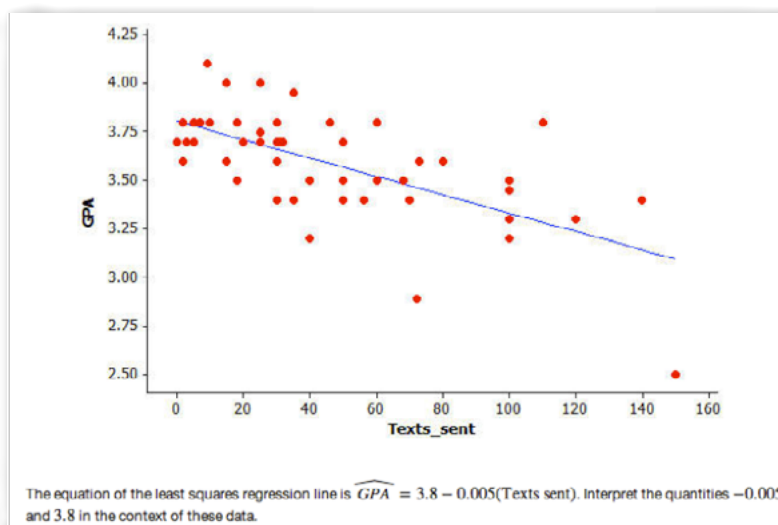

(<http://www.illustrativemathematics.org/illustrations/1028>)

Commentary *for the Teacher:*

The purpose of this task is to assess ability to interpret the slope and intercept of the least squares regression line in context. There are two common errors that students make when interpreting the slope. Students may not make it clear that the slope is the predicted change (not necessarily an actual change) in GPA associated with an increase of one in number of text messages sent. They also often do not clearly communicate that the slope describes change.

You might want to point out that in a linear regression setting, it is not always reasonable to interpret the intercept as the predicted y value when $x = 0$, as this often involves extrapolation far beyond the range of the x values in the data set. In this example, however, it is appropriate because there are observations with $x = 0$ in the data set.

You can also point out that the interpretation of the slope and intercept represents a generalization from the sample of 52 students to the population of all students at the school. This is appropriate because the sample was a random sample of students from the school.

Although this task is short and looks simple, some of the points brought out in this task are subtle. It might be a good strategy to engage in a whole class discussion of the correct interpretations.

Possible Solution:

Interpretation of the slope: For students at this school, the predicted GPA decreases by 0.005 for each additional text message sent or GPA decreases by 0.005, on average, for each additional text message sent.

Interpretation of intercept: The model predicts that students at this school who send no text messages have, on average, a GPA of 3.8.

Closing Activity



INCLUDED IN THE STUDENT MANUAL

Task #19: Olympic Gold Medalist

The scatterplot below shows the finishing times for the Olympic gold medalist in the men's 100-meter dash for many previous Olympic games. The least squares regression line is also shown. (Source: <http://trackandfield.about.com/od/sprintsandrelays/qt/olymp100medals.htm>.)

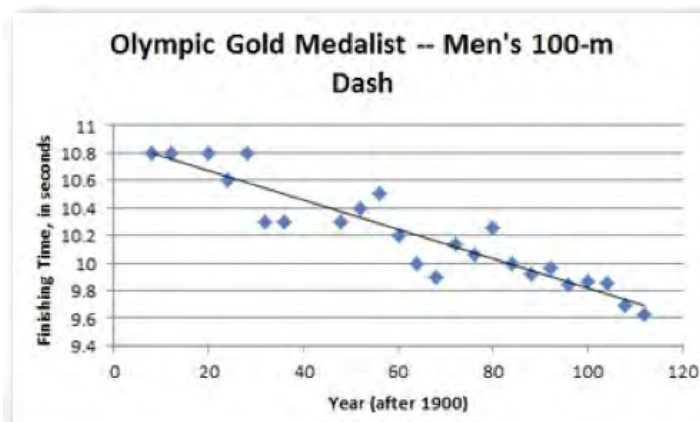

- a. Is a linear model a good fit for the data? Explain, commenting on the strength and direction of the association.
- b. The equation of the linear function that best fits the data (regression line) is $\widehat{\text{Finishing time}} = 10.878 - 0.0106(\text{Year after 1900})$. Given that the summer Olympic games only take place every four years, how should we expect the gold medalist's finishing time to change from one Olympic games to the next?
- c. What is the vertical intercept of the function's graph? What does it mean in context of the 100-meter dash?
- d. Note that the gold medalist finishing time for the 1940 Olympic games is not included in the scatterplot. Use the model to estimate the gold medalist's finishing time for that year.
- e. What is a realistic domain for the linear regression function? Comment on how your answer pertains to using this function to make predictions about future Olympic 100-m dash race times.

(<http://www.illustrativemathematics.org/illustrations/1554>)

Commentary *for the Teacher:*

The task asks students to identify when two quantitative variables show evidence of a linear association, and to describe the strength and direction of that association. Students then utilize a least-squares regression line to make predictions, and to make conjectures about the limitations of the model, which is a very important aspect of MP 4 - Model with Mathematics. They must apply their knowledge of slope and intercept of a linear function in context of the problem (i.e., understand that the slope of a regression line is the predicted change in the response variable per unit change of the explanatory variable, and that the vertical intercept corresponds to a value of zero in the explanatory variable).

Linear models are a very nice connection between statistics and functions in high school mathematics. Coherence in high school mathematics means drawing connections between topics that use the same mathematical concept. In this case we use linear functions to model the relationship between two quantitative variables. We can use the context of investigating if there is an association between two variables to strengthen our understanding of slope and intercept of a linear function.

This task is probably most appropriate for use in instruction. Consider having students work together in pairs or small groups on parts a - d. Part e could then be the basis for a whole class discussion.

*Note in solution, $\widehat{\{\text{Finishing Time}\}}$ means use notation as displayed on the Illustrative Mathematics site.

Solution:

- a. The data in the scatterplot are from two quantitative variables (year and finishing time), and the overall pattern is linear. There are also no obvious outliers, so it is reasonable to fit a linear model to the data. The direction of the association is negative (finishing time decreases as the year after 1900 increases), and the association is strong because the points are tightly clustered in a linear form.

- b. The slope of the regression equation is -0.0106 . This means for every year that passes, we would predict that the finishing time for the 100-m dash decreases by 0.0106 seconds. Since the Olympics take place every four years, we would expect the predicted gold medalist's finishing time to decrease by $4(0.0106)=0.0424$ seconds from one Olympic games to the next.
- c. The vertical intercept of the regression equation's graph is 10.878 . In context, this would be the predicted finishing time (in seconds) for the 100-m dash gold medalist in the 1900 Olympic games.
- d. To predict the finishing time for the 1940 gold medalist, we would simply substitute $\text{Years after } 1900 = 40$ into the regression equation to solve for $\widehat{\text{Finishing Time}}$. This yields $\widehat{\text{Finishing Time}} = 10.878 + 0.0106(40) = 10.454$. The predicted finishing time for the 1940 gold medalist is 10.454 seconds.
- e. At the most basic level, we know that the model will fail to be realistic once we obtain predicted racing times of zero or less. Substituting 0 into the equation for $\widehat{\text{Finishing Time}}$, we can solve for $\text{Years after } 1900 \approx 1026.2$. This equates to roughly the year 2926. If we take into account the current four-year rotation for the summer Olympic games, however, we see that the model will only provide a positive prediction up through the Olympic games in the year 2924. To be even more realistic, we should expect any 100-m dash to be completed in some positive amount of time; however, it may be difficult for students to put a specific value on a reasonable result. This discussion could also open up the topic of extrapolation versus interpolation when using linear regression models.

Resources/Instructional Materials Needed:

- If possible, it would be best to have three cloth measuring tapes, like the type used in sewing. If cloth tapes are unavailable, yardsticks will work as well.
- Computer projector for slides (or paper handouts).

Notes:

SREB Readiness Courses
Transitioning to college and careers

College Readiness Mathematics

Unit 8 . Summarizing and
Interpreting Statistical Data

Student Manual
Version 3

Name



Unit 8 . Summarizing and Interpreting Statistical Data

Table of Contents

Lesson 1.....	3
Lesson 2.....	6
Lesson 3.....	11
Lesson 4.....	17
Lesson 6.....	21
Lesson 7.....	27
Lesson 8.....	31

Statistics: Summarizing and Interpreting Data

In-Class Survey

The purpose of this survey is to provide data for use during the semester. Individuals will not be identified. You may leave any answers blank.

1. Are you male or female?
2. What is your height in inches (e.g., 5'6" = 66 inches)? _____
3. Are you right or left-handed? _____
4. How many siblings do you have? _____
5. What is your birth order (1=oldest/only child, 2=second oldest, etc.)? _____
6. How many hours of exercise do you get in a typical week? _____
7. On average, how many hours of television do you watch per week? _____
8. Make up a very random four-digit number. _____
9. Which award would you rather win: Academy Award, Olympic Gold or Nobel Prize?
10. Record your pulse (beats/minute) after measuring it in class. _____
11. How many piercings (ear, nose, etc.) do you have (count each hole)? _____
12. About how many friends do you have on Facebook (zero if not on Facebook)? _____
13. How many text messages do you send in a typical day? _____
14. What is your preferred social network (Facebook, Twitter, Instagram, FourSquare, etc.)?

15. How do you commute to school? _____
16. Do you use a Mac or PC? _____
17. How many hours of sleep do you get on a typical night? _____

Task #1: Movie Dataset

Film	Lead Studio	Audience score %	Genre	Number of Theatres in US Opening Weekend	Budget (millions of dollars)
Cars 2	Pixar	56	Animation	4115	200
Dolphin Tale	Independent	81	Drama	3507	37
Green Lantern	Warner Bros	48	Action	3816	200
Harry Potter and the Deathly Hallows Part 2	Warner Bros	92	Fantasy	4375	125
Mission Impossible 4	Paramount	86	Action	3448	145
Moneyball	Columbia	89	Drama	2993	50
50/50	Independent	93	Comedy	2458	8
Apollo 18	Weinstein Company	31	Horror	3328	5
Captain America: The First Avenger	Disney	75	Action	3715	140
Contagion	Warner Bros	63	Thriller	3222	60
The Muppets	Disney	87	Comedy	3440	45
X-Men: First Class	Disney	88	Action	3641	160
Zookeeper	Happy Madison Productions	42	Comedy	3482	80

Identify the cases in the dataset.

Identify all of the variables contained in the dataset, and determine whether each variable is quantitative or categorical.

Independent Practice Questions

1. For each situation described below, what are the cases? What is the variable? Is the variable quantitative or categorical?

a. People in a city are asked whether they support increasing the driving age to 18 years old.

b. Measure how many hours a fully charged laptop battery will last.

c. The value of tips a taxi driver receives for each trip.

d. Compare the poverty rates of each country in the world.

2. The manager of a reviews sales and wants to determine whether the amount of sales is associated to the weather outside. How the data is recorded determines whether the variables are quantitative or categorical. Describe how each variable could be measured quantitatively. Describe how each variable could be measured categorically.

“The Star-Spangled Banner”

What is the average length of a word in the “Star-Spangled Banner?”

The first two verses of the “Star-Spangled Banner” are given below. Your task is to select a sample of 10 words you will use to estimate the average length of all words in the first two verses of the song. Pick words that appear to be representative of the population of all the words. Circle the 10 words you choose.

What are the lengths (number of letters) for each of the 10 words you selected?

Note: Do not count apostrophes as letters. For example, “dawn’s” is a word that has a length of five. A hyphenated word, such as star-spangled, counts as a single word.

The “Star-Spangled Banner” (first two verses)	Word	Length
O say can you see, by the dawn’s early light,		
What so proudly we hailed at the twilight’s last gleaming,		
Whose broad stripes and bright stars through the perilous fight,		
Over the ramparts we watched were so gallantly streaming?		
And the rocket’s red glare, the bombs bursting in air,		
Gave proof through the night that our flag was still there,		
O say does that star-spangled banner yet wave,		
Over the land of the free and the home of the brave?		
On the shore dimly seen through the mists of the deep,		
Where the foe’s haughty host in dread silence reposes,		
What is that which the breeze, over the towering steep,		
As it fitfully blows, half conceals, half discloses?		
Now it catches the gleam of the morning’s first beam,		
In full glory reflected now shines in the stream,		
This the star-spangled banner, O long may it wave		
Over the land of the free and the home of the brave!		

Calculate the average number of letters for the 10 words in your sample. _____

Record the average here: _____

“Star-Spangled Banner”: Sampling Revisited

Find each of the 10 words corresponding to the 10 random numbers (between one and 158) that have been assigned to you. Count the number of letters in each of these words and compute the average number of letters in the words in your sample.

O	say	can	you	see	by	the	dawn’s	early	light
1	2	3	4	5	6	7	8	9	10
What	so	proudly	we	hailed	at	the	twilight’s	last	gleaming
11	12	13	14	15	16	17	18	19	20
Whose	broad	stripes	and	bright	stars	through	the	perilous	fight
21	22	23	24	25	26	27	28	29	30
o’er	the	ramparts	we	watched	were	so	gallantly	streaming	And
31	32	33	34	35	36	37	38	39	40
the	rocket’s	red	glare	the	bombs	bursting	in	air	gave
41	42	43	44	45	46	47	48	49	50
proof	through	the	night	that	our	flag	was	still	there
51	52	53	54	55	56	57	58	59	60
O	say	does	that	star-spangled	banner	yet	wave	o’er	the
61	62	63	64	65	66	67	68	69	70
land	of	the	free	and	the	home	of	the	brave
71	72	73	74	75	76	77	78	79	80
On	the	shore	dimly	seen	through	the	mists	of	the
81	82	83	84	85	86	87	88	89	90
deep	Where	the	foe’s	haughty	host	in	dread	silence	reposes
91	92	93	94	95	96	97	98	99	100
What	is	that	which	the	breeze	o’er	the	towering	steep
101	102	103	104	105	106	107	108	109	110
As	it	fitfully	blows	half	conceals	half	discloses	Now	it
111	112	113	114	115	116	117	118	119	120
catches	the	gleam	of	the	morning’s	first	beam	In	full
121	122	123	124	125	126	127	128	129	130
glory	reflected	now	shines	in	the	stream	T’is	the	star-spangled
131	132	133	134	135	136	137	138	139	140
banner	O	long	may	it	wave	O’er	the	land	of
141	142	143	144	145	146	147	148	149	150
the	free	and	the	home	of	the	brave		
151	152	153	154	155	156	157	158		

Task #2: Hours Spent Studying

Suppose you want to estimate the average number of hours that students in our school spend studying each week. Which of the following is the best method of sampling?

- a. Go to the library and ask all the students there how much they study.
- b. Email all students asking how much they study, and use all the data you get.
- c. Choose a sample of friends that resembles the general population of students at our school.
- d. Anonymously survey each student in our class. Require all students to respond.
- e. Stop people at random walking in the halls between classes and ask how much time they spend studying.

Correlation or Causation?

Decide whether each of the statement implies causation or simply association without causation. Identify whether each of the variables in the statement is a categorical or quantitative variable. Identify which variable is the explanatory and which is the response variable. Be sure to base your decision on the wording of the statement, not on your beliefs.

1. If you study more, your grades will improve.

2. Aging of the brain tends to be delayed in people with a college education.

3. Car owners tend to live longer than people who do not own a car.

4. A bad weather forecast leads to less students walking to school.

5. Seatbelts reduce the risk of a severe injury in a car accident.

Task #7: Strict Parents

Students in a high school mathematics class decided that their term project would be a study of the strictness of the parents or guardians of students in the school. Their goal was to estimate the proportion of students in the school who thought of their parents or guardians as “strict”. They do not have time to interview all 1,000 students in the school, so they plan to obtain data from a sample of students.

a. Describe the parameter of interest and a statistic the students could use to estimate the parameter.

b. Is the best design for this study a sample survey, an experiment, or an observational study? Explain your reasoning.

c. The students quickly realized that, as there is no definition of “strict,” they could not simply ask a student, “Are your parents or guardians strict?” Write three questions that could provide objective data related to strictness.

d. Describe an appropriate method for obtaining a sample of 100 students, based on your answer in part (a) above.

(Source: Illustrative Mathematics)

Left or Right Handed? Mac or PC?

Display the data in a two-way table such as the one below.

	Left	Right	Total
Mac	2	8	10
PC	1	14	15
	3	22	25

1. What proportion of students is left-handed? Right-handed?

2. What proportion of students use a Mac? A PC?

3. What proportion of students is left-handed and use a Mac?

4. What proportion of Mac users is right-handed?

5. What proportion of Mac users is left-handed?

6. What proportion of right-handed students use a Mac?

7. What proportion of left-handed students use a Mac?

8. If we want to determine whether left-handed people are more likely to use a Mac than right-handed people, which pair of proportions is more relevant to consider, the proportions in questions four and five or the proportions in six and seven? Why?

9. Do you think the difference is significant?

(Source: Illustrative Mathematics)

Task #10: Vaccine Recipients

In a study of 500 children from a city, 238 were randomly selected to receive a new vaccine. The other 262 children were randomly selected to receive a placebo. The children and the physicians did not know to which group they have been assigned. After five years, 22 of the 238 children who received the vaccine had been infected with malaria; while 28 out of the 262 children who received the placebo had been infected with malaria.

a. Is this an experiment or an observational study?

b. What are the variables? Which are categorical/quantitative? Explanatory/response?

c. Using the information above, set up a two-way table to determine whether the vaccine is effective.

d. Use your two-way table to determine whether the vaccine is effective or not.

e. Do you believe the vaccine is effective?

Task #11: Musical Preferences

The 54 students in one of several middle school classrooms were asked two questions about musical preferences: “Do you like rock?” “Do you like rap?” The responses are summarized in the table below.

	Likes Rap	Doesn't Like Rap	Total
Likes Rock	27	6	33
Doesn't Like Rock	4	17	21
Total	31	23	54

a. Is this a random sample, one that fairly represents the opinions of all students in the middle school?

b. What percentage of the students in the classroom like rock?

c. Is there evidence in this sample of an association in this class between liking rock and liking rap? Justify your answer by pointing out a feature of the table that supports it.

d. Explain why the results for this classroom might not generalize to the entire middle school.

(Source: Illustrative Mathematics)

Task #12: High Temperatures

The high temperature for each day in 2013 is displayed for three different cities on each of the three histograms below.

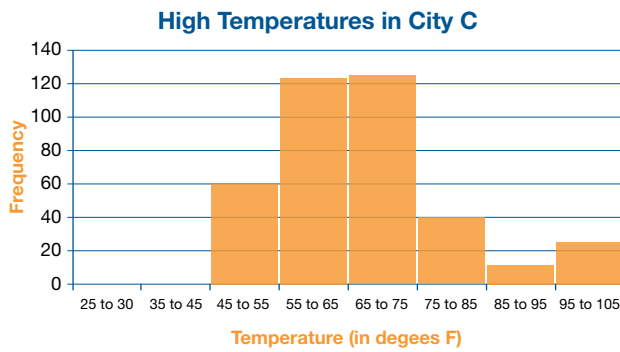
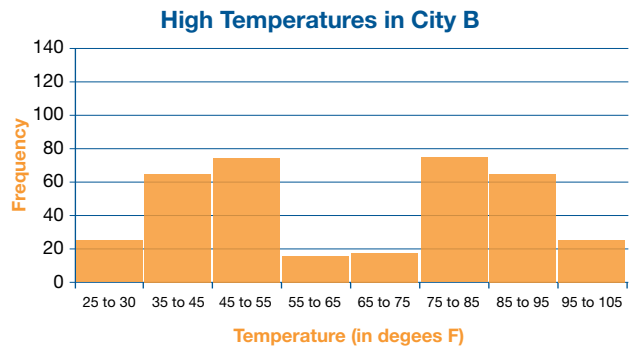
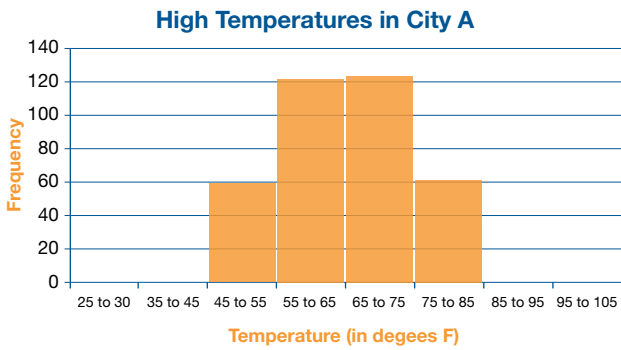

1. How many values are being displayed in each histogram?

2. Explain in this context what it means that city A has a histogram where the height of the bar over the range 45 to 55 is 60?

3. Which city had the most days with a high less than 32 degrees F? _____

4. Which city had the most days over 90 degrees F? _____

5. Approximate the median in each of three graphs. Explain how you determined your answer.

6. If the three graphs represent the high temperature for all 365 days in 2013 in three different cities, write a sentence summarizing the weather of each city in 2013. Which city would you prefer to live in?

7. Which city had the greatest mean high temperature in 2013? How did you determine your answer?

8. Which city has the smallest mean?

Task #13: Insuring a Car

The histogram below shows the distribution in the values of the average cost of insuring a car in each of the fifty states and the District of Columbia.

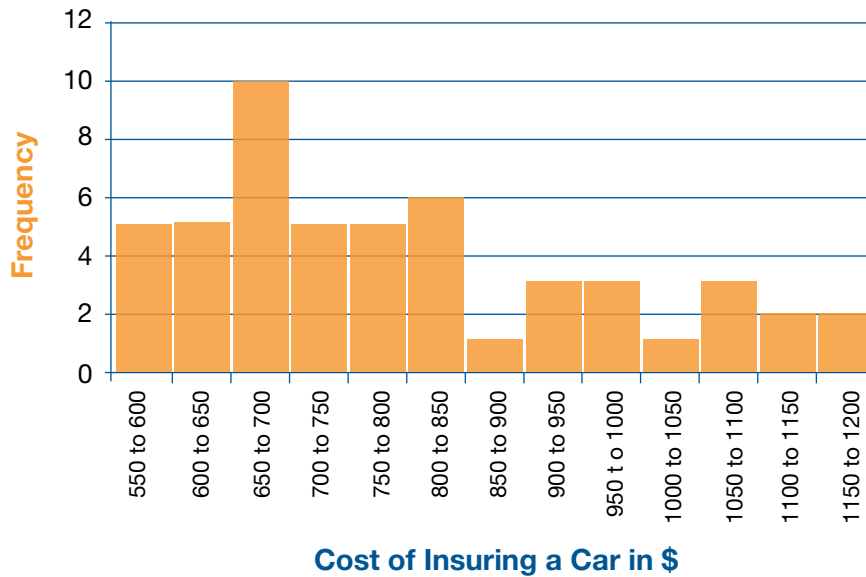

Approximate the median of this distribution. Round your answer to one decimal place and use the appropriate notation when expressing your answer.

Will the mean cost of insuring a car be more or less than the median? How can you tell?

(data found at <http://www.census.gov/hhes/www/hlthins/data/historical/index.html>)

Task #15: The Shape and Center of Data: Quiz Scores

A college statistics professor gave the same quiz (scored out of a total of 10 points) to his students over the past seven years. The distribution of the scores are displayed in the histograms labeled (i)-(vi) below.

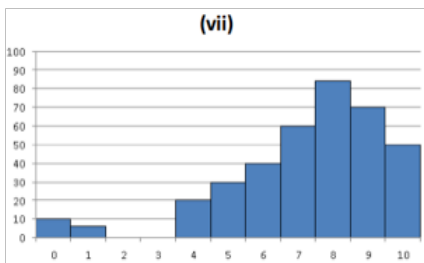
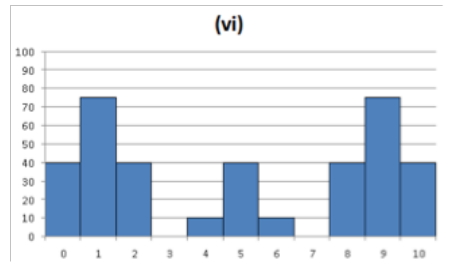
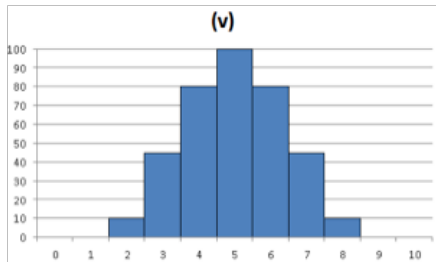
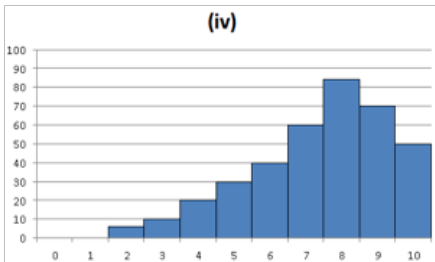
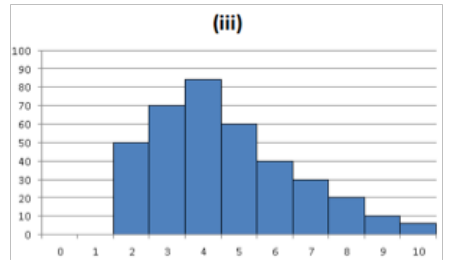
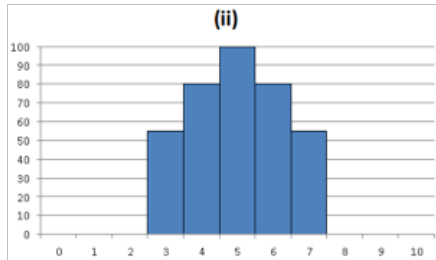
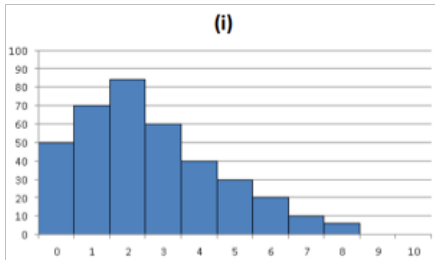

1. Which histogram(s) have a mean which is greater than its median? What does this imply about the distribution of the students' scores?

2. Which histogram(s) have a mean which is equal to its median? What does this imply about the distribution of the students' scores?

3. Which histogram appears to have the smallest mean? Interpret what this means in the context of quiz performance.

4. Which histogram appears to have the largest mean? Interpret what this means in the context of quiz performance.

5. Which histogram appears to have the largest standard deviation? Interpret what this means in the context of quiz performance.

6. Which histogram appears to have the smallest standard deviation? Interpret what this means in the context of quiz performance.

3. Correlations for each pair

The correlation coefficient, denoted by r , is a measure of the strength of the linear association between two variables. Use the values shown in the slides to record the correlation for each of the six pairs of variables, (a) – (f).

	correlation		correlation
(a) Weight vs. CityMPG		(d) Weight vs. QtrMile	
(b) Weight vs. FuelCap		(e) Acc060 vs. QtrMile	
(c) PageNum vs. FuelCap		(f) CityMPG vs. QtrMile	

4. Properties of correlation

Based on your observations of the scatterplots and computed correlations, write down at least three properties that would appear to be true about a sample correlation and its interpretation.

(1)

(2)

(3)

Task #17: Academic Achievement

Medhavi suspects that there is a relationship between the number of text messages high school students send and their academic achievement. To explore this, she asks each student in a random sample of 52 students from her school how many text messages he or she sent yesterday and what his or her grade point average (GPA) was during the most recent marking period. The data are summarized in the scatter plot of number of text messages sent versus GPA, shown below.

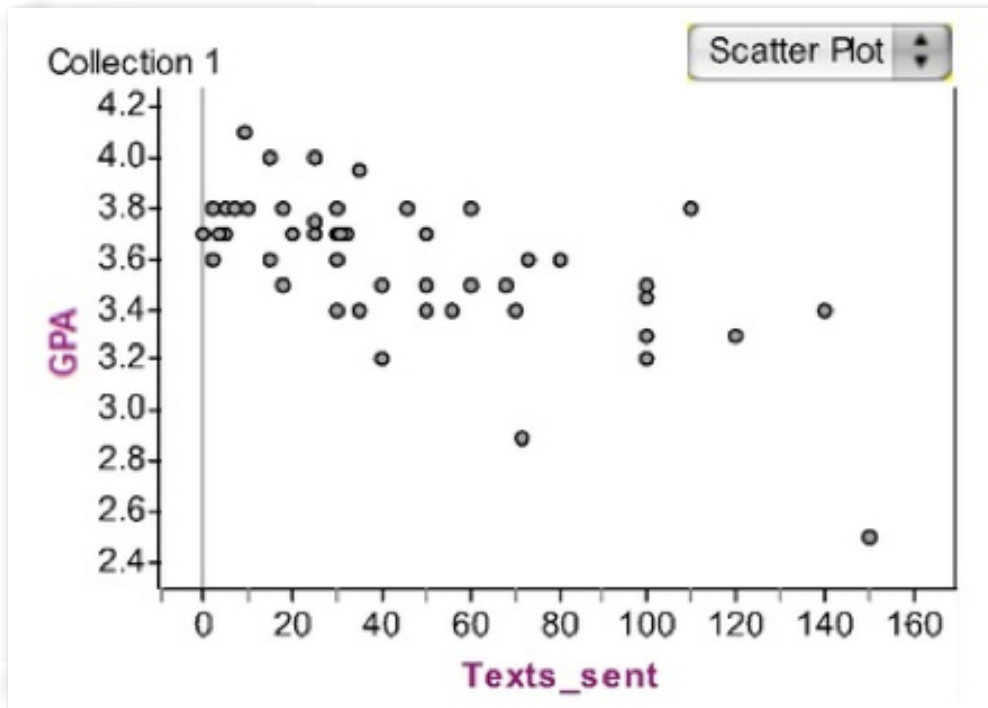

Describe the relationship between number of text messages sent and GPA. Discuss both the overall pattern and any deviations from the pattern.

(Source: Illustrative Mathematics)

Task #18: Academic Achievement #3

Medhavi suspects that there is a relationship between the number of text messages high school students send and their academic achievement. To explore this, she asks a random sample of 52 students at her school how many text messages they sent yesterday and what their grade point average (GPA) was during the most recent marking period. Her data are summarized in the scatter plot below. The least squares regression line is also shown.

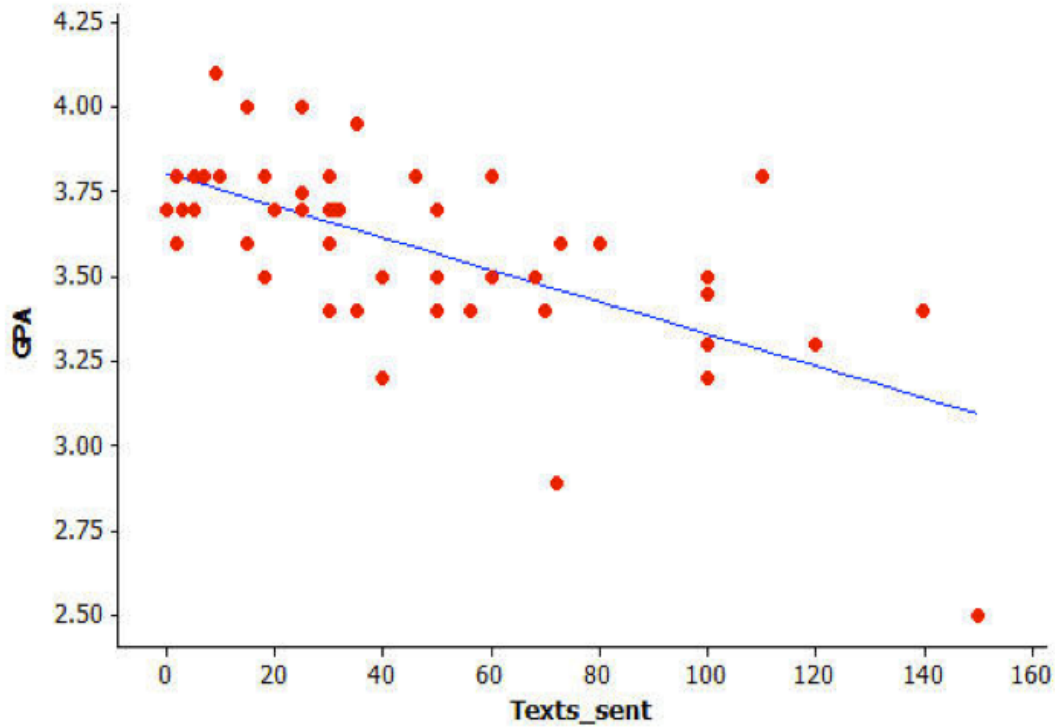

The equation of the least squares regression line is $\widehat{GPA} = 3.8 - 0.005(\text{Texts sent})$. Interpret the quantities -0.005 and 3.8 in the context of these data.

(Source: Illustrative Mathematics)

Task #19: Olympic Gold Medalist

The scatterplot below shows the finishing times for the Olympic gold medalist in the men’s 100-meter dash for many previous Olympic games. The least squares regression line is also shown. (Source: <http://trackandfield.about.com/od/sprintsandrelays/qt/olymp100medals.htm>.)

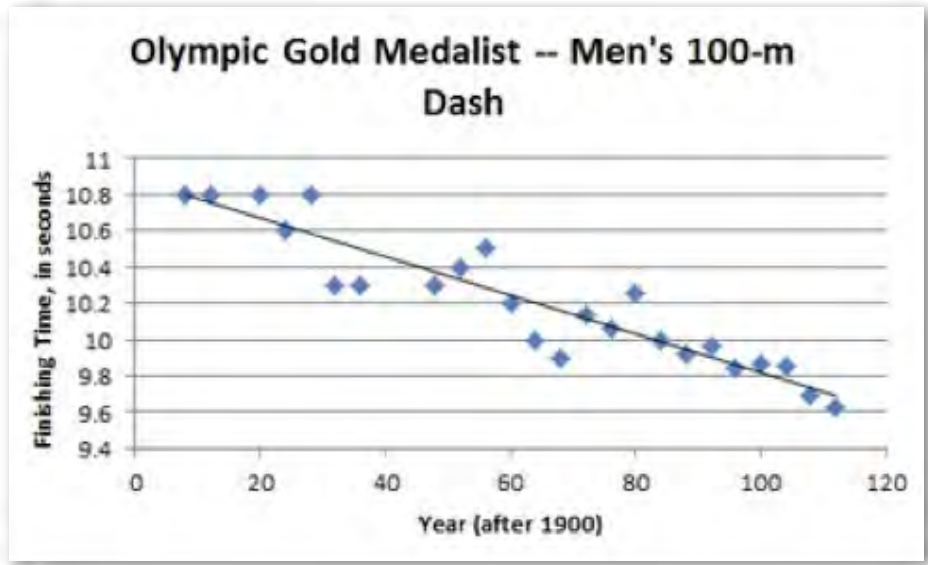

a. Is a linear model a good fit for the data? Explain, commenting on the strength and direction of the association.

b. The equation of the linear function that best fits the data (regression line) is $\hat{y} = 10.878 - 0.0106(\text{Year after 1900})$. Given that the summer Olympic games only take place every four years, how should we expect the gold medalist’s finishing time to change from one Olympic games to the next?

References

Unit 1 Resources:

Task #1: Bucky the Badger

Meyer, Dan. “Bucky the Badger” (Three-Act Math). Video. Dan Meyer — <http://mrmeyer.com/threeacts/buckythebadger/>.

Task #2: Reasoning about Multiplication and Division and Place Value

“6.NS Reasoning about Multiplication and Division and Place Value, Part 1.” Illustrative Mathematics, Illustrations. Creative Commons — <http://www.illustrativemathematics.org/illustrations/272>.

Task #3: Felicia’s Drive

“N-Q Felicia’s Drive.” Illustrative Mathematics, Illustrations. Creative Commons — <http://www.illustrativemathematics.org/illustrations/80>.

Task #4: Miles to Kilometers

“7.EE Miles to Kilometers.” Illustrative Mathematics, Illustrations. Creative Commons — <http://www.illustrativemathematics.org/illustrations/433>.

Task #5: Swimming Pool

Common Core Standards Writing Team. *Progressions for The Common Core State Standards in Mathematics (Draft)*. Grades 6-8, Middle School, Expressions and Equations. Institute for Mathematics and Education, University of Arizona, April 22, 2011 — <http://ime.math.arizona.edu/progressions/>.

Task #8: Sidewalk Patterns

“A06, Sidewalk Patterns.” Mathematics Assessment Project. Mathematics Assessment Resource Service, University of Nottingham and UC Berkeley, 2013 — <http://map.mathshell.org/materials/tasks.php?taskid=254&subpage=apprentice>
Interpreting Algebraic Expressions. Formative Assessment Lesson. Formative Assessment Lesson. Mathematics Assessment Resource Service. University of Nottingham and UC Berkeley, 2012 — <http://map.mathshell.org/materials/download.php?fileid=694>.

Task #10: Kitchen Floor Tiles

“A-SSE Kitchen Floor Tiles.” Illustrative Mathematics, Illustrations. Creative Commons — <http://www.illustrativemathematics.org/illustrations/215>.

Task #11: Distributive Property Using Area and Task #12: Factoring a Common Factor Using Area

“Distributive Properties Using Area” and other topics. Worksheet. Illuminations, National Council of Teachers of Mathematics, 2007 — <http://illuminations.nctm.org/lessons/6-8/DistribArea/distrib-AS-AreaForDistrib.pdf>.

Unit 2 Resource Sheet:

Mathematics Assessment Project (Shell Center):

Formative Assessment Lesson: Sorting Equations and Identities

Sorting Equations and Identities. Formative Assessment Lesson. Mathematics Assessment Resource Service. University of Nottingham and UC Berkely, 2012 — <http://map.mathshell.org/materials/download.php?fileid=688>.

Illustrative Math:

Task #5: Same Solutions

“Same Solutions?” Illustrative Mathematics, Illustrations. Creative Commons, 2013 — <http://www.illustrativemathematics.org/illustrations/613>.

Task #8: How Does the Solution Change?

“A-REI, How Does the Solution Change?” Illustrative Mathematics, Illustrations. Creative Commons, 2013 — <http://www.illustrativemathematics.org/illustrations/614>.

Task #10: Buying a Car

“A-CED, Buying a Car.” Illustrative Mathematics, Illustrations. Creative Commons, 2013 — <http://www.illustrativemathematics.org/illustrations/582>.

Task #12: Equations and Formulas

“A-CED, Equations and Formulas.” Illustrative Mathematics, Illustrations. Creative Commons, 2013 — <http://www.illustrativemathematics.org/illustrations/393>.

Task #15: Fishing Adventures

“7.EE, Fishing Adventures 2.” Illustrative Mathematics, Illustrations. Creative Commons, 2013 — <http://www.illustrativemathematics.org/illustrations/643>.

Task #16: Sports Equipment Set

“7.EE, Sports Equipment Set.” Illustrative Mathematics, Illustrations. Creative Commons, 2013 — <http://www.illustrativemathematics.org/illustrations/986>.

Task #17: Basketball

“A-CED, A-REI, Basketball.” Illustrative Mathematics, Illustrations. Creative Commons, 2013 — <http://www.illustrativemathematics.org/illustrations/702>.

Unit 3 Resource Sheet:

Mathematics Assessment Project (Shell Center):

Formative Assessment Lesson: Evaluating Statements About Enlargements (2D and 3D)

Evaluating Statements About Enlargements (2D and 3D). Formative Assessment Lesson. Mathematics Assessment Resource Service. University of Nottingham and UC Berkeley, 2012 — <http://map.mathshell.org/materials/download.php?fileid=678>.

Formative Assessment Lesson: Calculating Areas and Volumes of Compound Objects

Calculating Areas and Volumes of Compound Objects. Formative Assessment Lesson. Mathematics Assessment Resource Service. University of Nottingham and UC Berkeley, 2012 — <http://map.mathshell.org/materials/download.php?fileid=684>.

Propane Tank

“E16: Propane Tanks.” Mathematics Assessment Project. Mathematics Assessment Resource Service. University of Nottingham and UC Berkeley, 2013 — <http://map.mathshell.org/materials/tasks.php?taskid=288&subpage=expert>.

Metric Speed Questions

“Metric Speed (Velocity).” Math is Fun. 2013 — <http://www.mathsisfun.com/measure/metric-speed.html>.

A Fuel-ish Question

Martin, W. Gary, and Terry Johanson (adaptation). “Feul for Thought.” Activity Sheet. National Council of Teachers of Mathematics, 2012 — http://www.nctm.org/uploaded-Files/Journals_and_Books/Books/FHSM/RSM-Task/Fuel_for_Thought.pdf.

Donald in Mathmagic Land

Donald in Mathmagic Land. Film Clip. Dir. Hamilton S. Luske. Walt Disney, 1959 — http://www.youtube.com/watch?v=oT_Bxgah9zc.

Golden Ratio Face Worksheet

Narain, David L. “The Perfect Face.” Activity. The Golden Ratio. David Narain, 2001 — <http://cuip.uchicago.edu/~dlnarain/golden/activity8.htm>.

Map Activity Sheet

“Map Activity Sheet.” Illuminations, National Council of Teachers of Mathematics, 2007 — <http://illuminations.nctm.org/LessonDetail.aspx?ID=L516>.

If You Hopped Like a Frog Activity

Schwartz, David. *If You Hopped Like a Frog*. Scholastic Press, 1999.

Cartoons and Scale Drawings by Sara Wheeler for the Alabama Learning Exchange

Wheeler, Sara. “Cartoons and Scale Drawings.” Lesson Plan. Alabama Learning Exchange, 2012 — http://alex.state.al.us/lesson_view.php?id=26285.

Comparing TV Areas Image

Lynch, Gerald. “CES 2012: Sharp Super-Sizing 8K Screens.” TechDigest, January 9, 2012 — <http://www.techdigest.tv/sharp-80-inch-8kvk.jpg>.

Area and Perimeter of Irregular Shapes

“Areas of Complex Shapes.” Free Math Resource, 2013 — <http://freemathresource.com/lessons/general-math/91-areas-of-complex-shapes>.

A Pen for Penny

Hess, John et al. “A Pen for Penny.” Worksheet. Area and Perimeter Unit Plan. Mathematics Education Partnership Program. National Security Agency, 2009 — http://www.nsa.gov/academia/_files/collected_learning/high_school/geometry/pen_for_penny.pdf.

Area of a Circle

Weisstein, Eric W. “Circle.” *MathWorld*. Wolfram Research, 2013 — <http://mathworld.wolfram.com/Circle.html>.

“7th Grade Mathematics: Unpacked Content.” Instructional Support Tools for Achieving New Standards. North Carolina department of Public Instruction, February 2012 — <http://www.dpi.state.nc.us/docs/acre/standards/common-core-tools/unpacking/math/7th.pdf>.

Unit 4 Resource Sheet

Mathematics Assessment Project (Shell Center):

Formative Assessment Lesson: Lines and Linear Equations

Lines and Linear Equations. Formative Assessment Lesson. Mathematics Assessment Resource Service, University of Nottingham and UC Berkeley, 2012 — <http://map.mathshell.org/materials/download.php?fileid=1282>.

Illustrative Math:

Task #2: Peaches and Plums

“8.EE, Peaches and Plums.” Illustrative Mathematics, Illustrations. Creative Commons — <http://www.illustrativemathematics.org/illustrations/55>.

Task #4: Coffee by the Pound

“8.EE, Coffee by the Pound.” Illustrative Mathematics, Illustrations. Creative Commons — <http://www.illustrativemathematics.org/illustrations/129>.

Task #5: Who has the best job?

“8.EE, Who Has the Best Job?” Illustrative Mathematics, Illustrations. Creative Commons — <http://www.illustrativemathematics.org/illustrations/184>.

Video Clip: Itunes App Downloads

Meyer, Dan. 25 Billion Downloads. Video. Vimeo, 2013 — <http://vimeo.com/37382647>.

Unit 5 Resource Sheet:

Mathematics Assessment Project (Shell Center):

Formative Assessment Lesson: Classifying Solutions

Classifying Solutions of Systems of Equations. Formative Assessment Lesson. Mathematics Assessment Resource Service, University of Nottingham and UC Berkely, 2012 — <http://map.mathshell.org/materials/download.php?fileid=1213>.

Formative Assessment Lesson: Boomerangs

Optimization Problems: Boomerangs. Formative Assessment Lesson. Mathematics Assessment Resource Service, University of Nottingham and UC Berkely, 2012 — <http://map.mathshell.org/materials/download.php?fileid=1241>.

Formative Assessment Lesson: Defining Regions

Defining Regions Using Inequalities. Formative Assessment Lesson. Mathematics Assessment Resource Service, University of Nottingham and UC Berkely, 2012 — <http://map.mathshell.org/materials/download.php?fileid=690>.

Best Buy Tickets Task

“Best Buy Tickets.” Worksheet. Mathematics Assessment Resource Service, 2011 — <http://map.mathshell.org/materials/download.php?fileid=824>.

Illustrative Math:

Task #6: Dimes and Quarters

“A-CED, Dimes and Quarters.” Illustrative Mathematics, Illustrations. Creative Commons — <http://www.illustrativemathematics.org/illustrations/220>.

Stapel, Elizabeth. “System-of-Equations Word Problems.” Purplemath. <http://www.purplemath.com/modules/systprob.htm>.

Task #8: How Many Solutions?

“8.EE, How Many Solutions?” Illustrative Mathematics, Illustrations. Creative Commons — <http://www.illustrativemathematics.org/illustrations/554>.

Task #14: Writing Constraints

“A-CED, Writing Constraints.” Illustrative Mathematics, Illustrations. Creative Commons — <http://www.illustrativemathematics.org/illustrations/610>.

Task #15: Fishing Adventures

“A-REI, Fishing Adventures 3.” Illustrative Mathematics, Illustrations. Creative Commons — <http://www.illustrativemathematics.org/illustrations/644>.

Task #16: Solution Sets

“A-REI, Solution Sets.” Illustrative Mathematics, Illustrations. Creative Commons — <http://www.illustrativemathematics.org/illustrations/1205>.

NCTM Illuminations:

Bergama Cartoon Dolls

“Supply and Demand.” Illuminations. National Council of Teachers of Mathematics, 2013 — <http://illuminations.nctm.org/LessonDetail.aspx?id=L382>.

Dirt Bike Act

“Dirt Bike Dilemma.” Worksheet. Illuminations. National Council of Teachers of Mathematics, 2008 — <http://illuminations.nctm.org/Lessons/Dirtbike/DirtBike-AS-Packet.pdf>.

Unit 6 Resource Sheet:

Mathematics Assessment Project (Shell Center):

Formative Assessment Lesson: Forming Quadratics

Forming Quadratics. Formative Assessment Lesson. Mathematics Assessment Resource Service. University of Nottingham and UC Berkeley, 2012 — <http://map.mathshell.org/materials/download.php?fileid=700>.

Table Tiling

“Table Tiling.” Worksheet. Mathematics Assessment Resource Service, 2011 — <http://map.mathshell.org/materials/download.php?fileid=818>.

Solving Quadratic Equations: Cutting Corners

“Solving Quadratic Equations: Cutting Corners.” Mathematics Assessment Project. Mathematics Assessment Resource Service, University of Nottingham and UC Berkeley, 2013 — <http://map.mathshell.org/materials/lessons.php?taskid=432&subpage=problem>.

Illustrative Math:

Task: Springboard Dive

“F-IF, A-REI, Springboard Dive.” Illustrative Mathematics, Illustrations. Creative Commons — <http://www.illustrativemathematics.org/illustrations/375>.

Task: Throwing a Ball

“A-CED, Throwing a Ball.” Illustrative Mathematics, Illustrations. Creative Commons — <http://www.illustrativemathematics.org/illustrations/437>.

Task: Two Squares

“A-REI, Two Squared are Equal.” Illustrative Mathematics, Illustrations. Creative Commons — <http://www.illustrativemathematics.org/illustrations/618>.

Video Clip: “A Super Cool Video About Quadratic Systems”

Burdak, Yana, et al., *A Super Cool Video About Quadratic Systems*. Video. December 12, 2011 — <http://www.youtube.com/watch?v=aGM04mFit0Q>.

Illuminations: Egg Launch Lesson from NCTM Illuminations

“Egg launch Contest.” Illuminations. National Council of Teachers of Mathematics, 2013 — <http://illuminations.nctm.org/LessonDetail.aspx?id=L738>.

Shodor – Conic Flyer

“Conic Flyer.” Interactive. Shoder, 2013 — www.Shodor.org/interactive/activities/conicflyer.

NC EMPT – Concentration Games

North Carolina Early Mathematics Placement Testing: A Reality Check for Your Child’s Readiness for College-Level Mathematics. North Carolina Early Mathematics Placement Test Program, East Carolina University, 2008-2009 — <http://digital.ncdcr.gov/cdm/ref/collection/p249901coll22/id/19631>.

Mathematics Teacher Activity

Marcus, Robin et al. “New Thinking About College Mathematics: Implications for High School Teaching.” *Mathematics Teacher*, Vol. 101, No. 5. December 2007.

References Unit 7

Lesson 1

“F-LE, Linear or Exponential?” Illustrative Mathematics, Illustrations. Creative Commons — <http://www.illustrativemathematics.org/illustrations/629>.

“F-LE, A-REI Population and Food Supply.” Illustrative Mathematics, Illustrations. Creative Commons — <http://www.illustrativemathematics.org/illustrations/645>.

Lesson 2

“E06: ‘Ponzi’ Pyramid Schemes.” Mathematics Assessment Project. Mathematics Assessment Resource Service, University of Nottingham and UC Berkeley, 2013 — <http://map.mathshell.org/materials/tasks.php?taskid=278&subpage=expert>.

“F-LE, Snail Invasion.” Illustrative Mathematics, Illustrations. Creative Commons — <http://www.illustrativemathematics.org/illustrations/638>.

“A-SSE, Forms of Exponential Expressions.” Illustrative Mathematics, Illustrations. Creative Commons — <http://www.illustrativemathematics.org/illustrations/1305>.

“F-LE, Exponential Functions.” Illustrative Mathematics, Illustrations. Creative Commons — <http://www.illustrativemathematics.org/illustrations/351>.

“F-LE, Illegal Fish.” Illustrative Mathematics, Illustrations. Creative Commons — <http://www.illustrativemathematics.org/illustrations/579>.

Lesson 3

“Best Credit Card Reviews.” Creditcards.org, 2013 — creditcards.org

“A-SSE, The Bank Account.” Illustrative Mathematics, Illustrations. Creative Commons — <http://www.illustrativemathematics.org/illustrations/390>.

Lesson 4

Comparing Investments. Mathematics Assessment Project. Mathematics Assessment Resource Service, University of Nottingham and UC Berkeley, 2013 — <http://map.mathshell.org/materials/lessons.php?taskid=426&subpage=concept>.

Unit 8 Resource Sheet:

Mathematics Assessment Project (Shell Center): Representing Data 1: Using Frequency Graphs. Formative Assessment Lesson. Mathematics Assessment Resource Service. University of Nottingham and UC Berkeley, 2012 — <http://map.mathshell.org/materials/download.php?fileid=1230>.

Illustrative Math:

Task #1: Public Dataset

Google Drive. Public Dataset — <https://docs.google.com/spreadsheet/ccc?key=0AltK3Tn01ZsWdEJ1cHFjbmVyejhnN1JnQINyWW5IUkE&authkey=CPuZiLcG-gid=29>.

Task #2: School Advisory Panel

“S-IC, School Advisory Panel.” Illustrative Mathematics, Illustrations. Creative Commons — <http://www.illustrativemathematics.org/illustrations/186>.

Task #3: High Blood Pressure

“S-IC, S-ID, Hi Blood Pressure.” Illustrative Mathematics, Illustrations. Creative Commons — <http://www.illustrativemathematics.org/illustrations/1100>.

Task #5: Golf and Divorce

“S-ID Golf and Divorce.” Illustrative Mathematics, Illustrations. Creative Commons — <http://www.illustrativemathematics.org/illustrations/44>.

Task #6: Strict Parents

“S-IC, Strict Parents.” Illustrative Mathematics, Illustrations. Creative Commons — <http://www.illustrativemathematics.org/illustrations/122>.

Task #7: Words and Music

“S-IC, Words and Music.” Illustrative Mathematics, Illustrations. Creative Commons — <http://www.illustrativemathematics.org/illustrations/1029>.

Task #10: Musical Preferences

“S-IC, S-ID, Musical Preferences.” Illustrative Mathematics, Illustrations. Creative Commons — Illustrative Mathematics, Illustrations. Creative Commons — <http://www.illustrativemathematics.org/illustrations/123>.

Task #14: Academic Achievement

“8-SP.1, Texting and Grades I.” Illustrative Mathematics, Illustrations. Creative Commons — <http://www.illustrativemathematics.org/illustrations/975>.

Task #15: Academic Achievement #2

“S-ID.7, Texting and Grades II” Illustrative Mathematics, Illustrations. Creative Commons — <http://www.illustrativemathematics.org/illustrations/1028>.

Task #17: Olympic Gold Medalist

“S-ID.6a,7, Olympic Men’s 100-Meter Dash.” Illustrative Mathematics, Illustrations. Creative Commons — <http://www.illustrativemathematics.org/illustrations/1554>.

SREB

Southern Regional Education Board
592 10th St. N.W.
Atlanta, GA 30318-5776
(404) 875-9211
www.SREB.org

For more information:
See SREB.org/Ready or scan the code.

