

# SREB

## SREB Readiness Courses

# Ready for High School: Math

Math Unit 1/2  
Fractions

Not for Review Copy Distribution

Southern  
Regional  
Education  
Board

592 Tenth Street, NW  
Atlanta, GA 30318  
(404) 875-9211

[www.sreb.org](http://www.sreb.org)

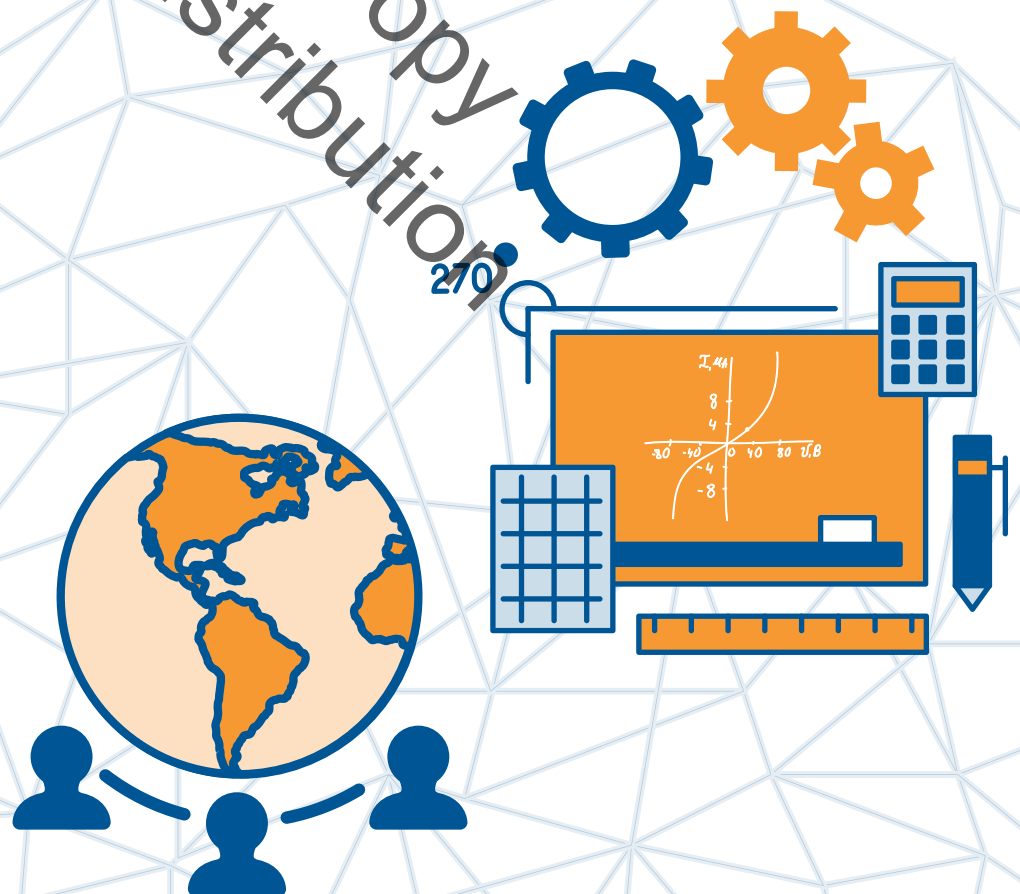

## Unit 1/2 . Fractions

### Overview

This introductory unit encourages a deeper understanding of order, comparison, and computation of fractions through exploration of different fractional models. Students will be encouraged to reflect upon which model works best to represent different situations and create connections between those models to encourage flexibility when solving problems. This unit also introduces students to the type of thinking, questioning, and the general approach to instruction they will encounter throughout the remainder of the course.

### Prior scaffolding knowledge/skills:

Extend understanding of fraction equivalence and ordering.

- Explain why a fraction  $\frac{a}{b}$  is equivalent to a fraction  $\frac{(n \times a)}{(n \times b)}$  by using visual fraction models, with attention to how the number and size of the parts differ even though the two fractions themselves are the same size. Use this principle to recognize and generate equivalent fractions.
- Compare two fractions with different numerators and different denominators, e.g., by creating common denominators or numerators, or by comparing to a benchmark fraction such as  $\frac{1}{2}$ . Recognize that comparisons are valid only when the two fractions refer to the same whole. Record the results of comparisons with symbols  $>$ ,  $=$ , or  $<$ , and justify the conclusions, e.g., by using a visual fraction model.
- Understand a fraction  $\frac{a}{b}$  with  $a > 1$  as a sum of fractions  $\frac{1}{b}$ .
  - Understand addition and subtraction of fractions as joining and separating parts referring to the same whole.
  - Decompose a fraction into a sum of fractions with the same denominator in more than one way, recording each decomposition by an equation. Justify decompositions, e.g., by using a visual fraction model. Examples:  $\frac{3}{8} = \frac{1}{8} + \frac{1}{8} + \frac{1}{8}$ ;  $\frac{3}{8} = \frac{1}{8} + \frac{2}{8}$ ;  $2\frac{1}{8} = 1 + 1 + \frac{1}{8} = \frac{8}{8} + \frac{8}{8} + \frac{1}{8}$ .
  - Add and subtract mixed numbers with like denominators, e.g., by replacing each mixed number with an equivalent fraction, and/or by using properties of operations and the relationship between addition and subtraction.
  - Solve word problems involving addition and subtraction of fractions referring to the same whole and having like denominators, e.g., by using visual fraction models and equations to represent the problem.

- Apply and extend previous understandings of multiplication to multiply a fraction by a whole number.
  - Understand a fraction  $\frac{a}{b}$  as a multiple of  $\frac{1}{b}$ . For example, use a visual fraction model to represent  $\frac{5}{4}$  as the product  $5 \times (\frac{1}{4})$ , recording the conclusion by the equation  $\frac{5}{4} = 5 \times (\frac{1}{4})$ .
  - Understand a multiple of  $\frac{a}{b}$  as a multiple of  $\frac{1}{b}$ , and use this understanding to multiply a fraction by a whole number. For example, use a visual fraction model to express  $3 \times (\frac{2}{5})$  as  $6 \times (\frac{1}{5})$ , recognizing this product as  $\frac{6}{5}$ . (In general,  $n \times (\frac{a}{b}) = (n \times \frac{a}{b})$ .)
  - Solve word problems involving multiplication of a fraction by a whole number, e.g., by using visual fraction models and equations to represent the problem. For example, if each person at a party will eat  $\frac{3}{8}$  of a pound of roast beef, and there will be 5 people at the party, how many pounds of roast beef will be needed? Between what two whole numbers does your answer lie?

### Essential Questions:

---

- How can models be used to determine, compute, compare, and order fractions with like and unlike denominators?
- How can models be used to determine and compare equivalent fractions?
- How are models used to show how fractional parts are combined or separated?
- How can models be used to understand the addition, subtraction, multiplication and division of fractions?

## College- and Career-Readiness Standards:

Use equivalent fractions as a strategy to add and subtract fractions.

- NF.1 Add and subtract fractions with unlike denominators (including mixed numbers) by replacing given fractions with equivalent fractions in such a way as to produce an equivalent sum or difference of fractions with like denominators. For example,  $\frac{2}{3} + \frac{5}{4} = \frac{8}{12} + \frac{15}{12} = \frac{23}{12}$ . (In general,  $\frac{a}{b} + \frac{c}{d} = \frac{ad + bc}{bd}$ .)
- NF.2 Solve word problems involving addition and subtraction of fractions referring to the same whole, including cases of unlike denominators, e.g., by using visual fraction models or equations to represent the problem. Use benchmark fractions and number sense of fractions to estimate mentally and assess the reasonableness of answers. For example, recognize an incorrect result  $\frac{2}{4} + \frac{1}{2} = \frac{3}{7}$ , by observing that  $\frac{3}{7} < \frac{1}{2}$ .

Apply and extend previous understandings of multiplication and division.

- NF.3 Interpret a fraction as division of the numerator by the denominator ( $\frac{a}{b} = a \div b$ ). Solve word problems involving division of whole numbers leading to answers in the form of fractions or mixed numbers, e.g., by using visual fraction models or equations to represent the problem. For example, interpret  $\frac{3}{4}$  as the result of dividing 3 by 4, noting that  $\frac{3}{4}$  multiplied by 4 equals 3, and that when 3 wholes are shared equally among 4 people each person has a share of size  $\frac{3}{4}$ . If 9 people want to share a 50-pound sack of rice equally by weight, how many pounds of rice should each person get? Between what two whole numbers does your answer lie?
- NF.4 Apply and extend previous understandings of multiplication to multiply a fraction or whole number by a fraction.
  - Interpret the product  $(\frac{a}{b}) \times q$  as a parts of a partition of  $q$  into  $b$  equal parts; equivalently, as the result of a sequence of operations  $a \times q \div b$ . For example, use a visual fraction model to show  $(\frac{2}{5}) \times 4 = \frac{8}{5}$ , and create a story context for this equation. Do the same with  $(\frac{2}{3}) \times (\frac{4}{5}) = \frac{8}{15}$ . (In general,  $(\frac{a}{b}) \times (\frac{c}{d}) = \frac{ac}{bd}$ .)
  - Find the area of a rectangle with fractional side lengths by tiling it with unit squares of the appropriate unit fraction side lengths, and show that the area is the same as would be found by multiplying the side lengths. Multiply fractional side lengths to find areas of rectangles, and represent fraction products as rectangular areas.
- NF.5 Interpret multiplication as scaling (resizing), by:
  - Comparing the size of a product to the size of one factor on the basis of the size of the other factor, without performing the indicated multiplication.
  - Explaining why multiplying a given number by a fraction greater than 1 results in a product greater than the given number (recognizing multiplication by whole numbers greater than 1 as a familiar case); explaining why multiplying a given number by a fraction less than 1 results in a product smaller than the given number; and relating the principle of fraction equivalence  $\frac{a}{b} = (n \times a)/(n \times b)$  to the effect of multiplying  $\frac{a}{b}$  by 1.
- NF.6 Solve real world problems involving multiplication of fractions and mixed numbers, e.g., by using visual fraction models or equations to represent the problem. For example, create a story context for  $(\frac{2}{3}) \div (\frac{3}{4})$  and use a visual fraction model to show the quotient; use the relationship between multiplication and division to explain

that  $(\frac{2}{3}) \div (\frac{3}{4}) = \frac{8}{9}$  because  $\frac{3}{4}$  of  $\frac{8}{9}$  is  $\frac{2}{3}$ . (In general,  $(\frac{a}{b}) \div (\frac{c}{d}) = \frac{ad}{bc}$ .) How much chocolate will each person get if 3 people share  $\frac{1}{2}$  lb of chocolate equally? How many  $\frac{3}{4}$  cup servings are in  $\frac{2}{3}$  of a cup of yogurt? How wide is a rectangular strip of land with length  $\frac{3}{4}$  mi and area  $\frac{1}{2}$  square mi?

- NF:7 Apply and extend previous understandings of division to divide unit fractions by whole numbers and whole numbers by unit fractions.
  - Interpret division of a unit fraction by a non-zero whole number, and compute such quotients. For example, create a story context for  $(\frac{1}{3}) \div 4$ , and use a visual fraction model to show the quotient. Use the relationship between multiplication and division to explain that  $(\frac{1}{3}) \div 4 = \frac{1}{12}$  because  $(\frac{1}{12}) \times 4 = \frac{1}{3}$ .
  - Interpret division of a whole number by a unit fraction, and compute such quotients. For example, create a story context for  $4 \div (\frac{1}{5})$ , and use a visual fraction model to show the quotient. Use the relationship between multiplication and division to explain that  $4 \div (\frac{1}{5}) = 20$  because  $20 \times (\frac{1}{5}) = 4$ .
  - Solve real world problems involving division of unit fractions by non-zero whole numbers and division of whole numbers by unit fractions, e.g., by using visual fraction models and equations to represent the problem. For example, how much chocolate will each person get if 3 people share  $\frac{1}{2}$  lb of chocolate equally? How many  $\frac{1}{3}$  cup servings are in 2 cups of raisins?

Apply and extend previous understandings of multiplication and division to divide fractions by fractions.

- NS.1 Interpret and compute quotients of fractions, and solve word problems involving division of fractions

Apply and extend previous understandings of operations with fractions.

- NS.3 Apply and extend previous understandings of multiplication and division and of fractions to multiply and divide rational numbers.

### Lesson Progression Overview:

Lesson Big Idea	Lesson Details	Content Standards	Process Readiness Indicators
<b>Lesson 1: (Entry Event) Fractions as Parts of Wholes and Parts of Set</b>	(This lesson will begin with the unit hook which serves to informally assess students' understanding of fractions)  In this lesson, students will use models to explain the meaning of the numerator and denominator in fractions. Students will use models to identify and represent the fraction of a whole and a group.	Prior Scaffolding Skills NF.4	PRI 2 PRI 3 PRI 6 PRI 7 PRI 9
<b>Lesson 2: Ordering Fractional Measures</b>	Students will compare and order fractions as measures with like and unlike denominators.	Prior Scaffolding Skills	PRI 1 PRI 2 PRI 3 PRI 5 PRI 7 PRI 10
<b>Lesson 3: Equivalent Fractions as a Result of Division</b>	Students will explore fractions as a result of division and use models to determine and compare equivalent fractions.	NF.3	PRI 1 PRI 3 PRI 5 PRI 6 PRI 7 PRI 8
<b>Lesson 4: Adding and Subtracting Fractions</b>	Students will use concrete materials and drawings to model how fractional parts are combined or separated	NF.1 NF.2	PRI 1 PRI 2 PRI 3 PRI 4 PRI 5 PRI 7 PRI 8
<b>Lesson 5: Multiplying and Dividing Fractions</b>	Students will use models to explore multiplication and division of fractions	NF.5 NF.6 NF.7 NS.3	PRI 1 PRI 3 PRI 5 PRI 9 PRI 10
<b>Lesson 6: Formative Assessment Lesson: Interpreting Multiplication and Division</b>	This lesson is designed to help students to interpret the meaning of multiplication and division with fractions using area models.	NS.1 NS.3	PRI 1 PRI 2 PRI 3 PRI 4 PRI 5 PRI 6 PRI 7 PRI 9 PRI 10

## Fractions

# Lesson 1 of 6

## Fractional Parts and Sets

### Description:

---

In this lesson, students will use models to explain the meaning of the numerator and denominator in fractions. Students will use models to identify and represent the fraction of a whole and a group.

### College- and Career-Readiness Standards Addressed:

---

- Prior Scaffolding Skills:
  - Explain why a fraction  $\frac{a}{b}$  is equivalent to a fraction  $(n \times a)/(n \times b)$  by using visual fraction models, with attention to how the number and size of the parts differ even though the two fractions themselves are the same size. Use this principle to recognize and generate equivalent fractions.
  - Compare two fractions with different numerators and different denominators, e.g., by creating common denominators or numerators, or by comparing to a benchmark fraction such as  $\frac{1}{2}$ . Recognize that comparisons are valid only when the two fractions refer to the same whole. Record the results of comparisons with symbols  $>$ ,  $=$ , or  $<$ , and justify the conclusions, e.g., by using a visual fraction model.
- NF.4 Apply and extend previous understandings of multiplication to multiply a fraction or whole number by a fraction.

### Process Readiness Indicator(s) Emphasized:

---

- PRI 2: Reason abstractly and quantitatively by using multiple forms of representations to make sense of and understand mathematics.
- PRI 3: Describe and justify mathematical understandings by constructing viable arguments, critiquing the reasoning of others and engaging in meaningful mathematical discourse.
- PRI 6: Attend to precision.
- PRI 7: Look for and make use of patterns and structure.
- PRI 9: Demonstrate flexible use of strategies and methods while reflecting on which procedures seem to work best for specific types of problems.

Sequence of  
Instruction

Activities Checklist

Engage

PRI 2  
PRI 3  
PRI 6

*Teacher Preparation Notes: Prior to beginning the Lesson - Position Fraction Station signs (attached at the end of this lesson), poster paper, and a stack of post-it notes on the wall throughout the room or along the hallway.*

Teachers will need to create a free Desmos account at <https://teacher.desmos.com/> to assign the independent practice in this lesson as well as other lessons.

**Activity 1: Get to Know One Another** (10 minutes)

As the opening lesson of the unit as well as the course, the lesson is meant to provide the means to formatively assess student conceptual understanding of fractions and to engage student prior knowledge but not necessarily to teach new content.

Create 3 random groups of students. Groups do NOT need to be equal in number.

Ask the following questions and record answers on the board to reinforce the importance of identifying the part and the whole:

- What fraction represents each person in your group? (varies depending on group size)
- What does the numerator represent? (person in the group)
- What does the denominator represent? (number of people in the group)
- Create a fraction to describe a portion of the members of your group. (i.e.  $\frac{3}{4}$  of the group is wearing flip-flops,  $\frac{5}{7}$  of the group is female,  $\frac{1}{9}$  of the group is born in November, etc.).

Switch members of groups and repeat.

Switch members of the groups again but make sure the groups are even in number (If you have an odd amount of students you can become part of the odd group to create evenly numbered groups).

This time tell the students to create a situation to describe  $\frac{1}{2}$  of their group.

Switch groups and repeat with  $\frac{3}{4}$  of the group.

Share situations whole class with a focus on identifying the part and whole.

Explore

PRI 2  
PRI 3  
PRI 6

**Activity 2: Playing Cards Stations** (25 minutes)

Give each student a playing card from the deck and a marker/pencil. Be sure to hand out a combination of both number cards and face cards. Set the stage for the following lesson by explaining to students that the playing cards and all of their characteristics (suit, number, color, face card/number card) will be used throughout the unit in different ways to ultimately gain a better understanding of fractional representation.

Refer students to the *Fraction Stations* positioned around the room/in the hallway. Each station includes a piece of poster paper and post-it notes upon which students will record their responses.



Just as you did in the introduction, students will construct different fractional representations using the cards they have been given. As they combine with other students in the room to create the fractions, they not only have to model their representation but they must be included in at least one representation at each station (they may be included in more than one model, if necessary). This activity not only allows students to create fractions as parts of a whole and parts of a set, but informally introduces them to equivalent fractions. This will allow your students to get to know one another and engage them in constructing viable arguments.

**Pose the Challenge:**

“Your challenge is to position yourselves in groups to create models representing the fractions posted around the room using the different characteristics of your playing cards with as *few models as possible at each station*. Your card must be included in some way at least once at every station by the end of the activity, although your card may be used more than once at any station. Draw your group’s fractional model as well as a verbal explanation of what it represents on the post-it notes provided. Place your group’s post-it on the **BACK** of the poster and record your initials on the station card before moving on to complete the rest. You may complete the stations in any order.”

*Teacher’s note: Placing the post-its on the back of the poster not only provides a large area for students to physically place and move their cards as they create the fractions, but is also meant to keep student decisions from being influenced by those models already created. If students truly understand the challenge, some stations will only have one model (if your class has an even number of students, they can all be part of the same model at the  $\frac{1}{2}$  Station)*

**Before beginning the activity:**

**2-minute Think, Turn and Talk:** “What is your strategy to begin this activity? What problems do you think you’ll run into?” Listen to student conversations as they discuss how to complete the task. Answer any logistical questions before they begin.

*Teacher’s Note: There are eight station cards provided including one ‘create your own’ station. Although students may be included in more than one model at each station, remind students that the challenge is to create the least amount of models at each station. Upon completion of the activity, this is a good place to pause the lesson if teaching in 45-minute periods.*

## Explanation

**PRI 1**  
**PRI 9**  
**PRI 10**

Arrange and affix the post-it notes to the front of the posters so that all fraction models are visible.

Ask the following questions for students to discuss with shoulder partners as you arrange the post-its (90-minute block) OR as their exit ticket (45-minute period).

*“Which station was the easiest to complete and why? Which station do you think was the most difficult to complete and why? What challenge(s) did you overcome? How was it accomplished?”*

Lead a whole class discussion about the responses to the questions above. Focus on which fractions were harder to create with fewer models and why. Be sure to involve students in the discussion if there were instances when students added on to models

that were already created. What did they have to consider? What strategies worked? What strategies needed revised? What were the 'aha's experienced throughout the activity?

At the end of the discussion, collect the cards and exchange each card for three (3) pattern blocks to be used by each student in the next activity.

To wrap up the discussion, be sure to reiterate the models students have created during the Fraction Stations activity are called area models. Area models of fractions are visual representations of sets that are divided into equal parts as determined by the denominator, and the fractional portion of the whole set is shaded to identify what part of the whole is represented.

### Practice Together / in Small Groups / Individually

#### PRI 5

Tell students that they will now use their experiences with proper fraction area models from the station activity to create fractional areas with pattern blocks. Based on your observations with the work on the station activity, homogeneously pair students to complete Task #1: Mosaic Models.

INCLUDED IN THE STUDENT MANUAL

#### Task #1: Mosaic Models

Work in pairs for this activity. Arrange your pattern blocks to design a "mosaic" area model. The area of your "mosaic" will be used for reference to answer parts a thru e.

Here is an example of a "mosaic" area model.

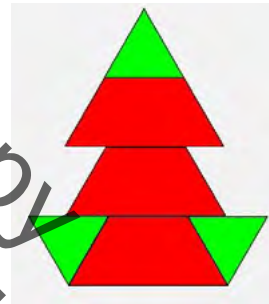

Return the unused pattern blocks to their container. Answer the following questions in pairs.

The mosaic you have created is the whole. For each fraction below, find the pieces of the mosaic and draw it on your paper.

- $\frac{1}{2}$  mosaic
- $1\frac{1}{3}$  mosaics
- 2 mosaics
- $\frac{1}{4}$  mosaic
- $\frac{2}{3}$  mosaic

#### Challenge:

If the students finish this task quickly and easily, challenge them to create a fraction of their own and draw the model that represents the fraction.

*Teacher Note: As students discuss how to create the models with their partners, listen for discussions concerning color, shape and position but do not offer the information before the activity.*

## Evaluate Understanding

### PRI 7

Now that students have explored creating parts from a whole with pattern blocks, they will now create the whole given the part. Students will complete TASK #2: Here's Your Part independently or as homework. When discussing student responses to the questions in Task #2, be sure to point out that the fraction model they used in question number two is called a set model. In the set model, the whole is understood to be a set of objects and the subsets are the fractional parts.

INCLUDED IN THE STUDENT MANUAL

#### Task #2: Here's Your Part...

1. If this rectangle is one-third, what could the whole look like? Show your thinking.



2. If 12 counters are **three-fourths** of a set, how many counters are in the full set? Show your thinking.

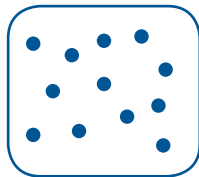

#### Task #2: Here's Your Part... (ANSWER KEY)

2. If this rectangle is one-third, what could the whole look like? Show and explain your thinking.

(Answers will vary. Sample representation shown below)

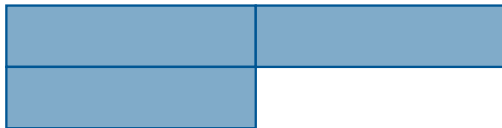

2. If 12 counters are three-fourths of a set, how many counters are in the full set? Show and explain your thinking.

Answers will vary. If 12 counters are  $\frac{3}{4}$  of the set, then 4 counters are  $\frac{1}{4}$  of the set.  $\frac{4}{4}$  make one whole set, so four 4s = 16

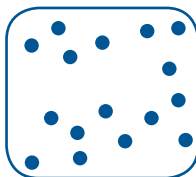

## Closing Activity

---

### Exit Slip – Note card

Tell students to draw the mosaic they created and any pattern block answer(s) they feel unsure about on one side of the note card. Write the fraction that is modeled on the back.

## Independent Practice:

---

Struggling students:

Pair activity: Desmos - [Polygraph: Shaded Rectangles](https://teacher.desmos.com/polygraph/custom/560aa8d79e65da561507a4ea)

<https://teacher.desmos.com/polygraph/custom/560aa8d79e65da561507a4ea>

Independent practice: [Area Model Concentration](https://illuminations.nctm.org/Activity.aspx?id=3563). Click on  $\frac{1}{2} - \frac{2}{3}$  option to play the game. <https://illuminations.nctm.org/Activity.aspx?id=3563>

## Resources/Instructional Materials Needed:

---

Task #1: Mosaic Models

Task #2: Here's Your Part

Post-it Notes

Note cards

Markers

Poster Paper

Fraction Station Cards

Playing Cards

Pattern Blocks

Not for Review Copy  
Not for Distribution



















## Fractions

# Lesson 2 of 6

## Ordering Fractional Measures

### Description:

---

Students will compare and order fractions as measures with like and unlike denominators.

### College- and Career-Readiness Standards Addressed:

---

- Prior Scaffolding Skills:
  - Compare two fractions with different numerators and different denominators, e.g., by creating common denominators or numerators, or by comparing to a benchmark fraction such as  $\frac{1}{2}$ . Recognize that comparisons are valid only when the two fractions refer to the same whole. Record the results of comparisons with symbols  $>$ ,  $=$ , or  $<$ , and justify the conclusions, e.g., by using a visual fraction model.
  - Understand a fraction  $\frac{a}{b}$  with  $a > 1$  as a sum of fractions  $\frac{1}{b}$ .

### Process Readiness Indicator(s) Emphasized:

---

- PRI 1: Make sense of problems and persevere in solving through reasoning and exploration.
- PRI 2: Reason abstractly and quantitatively by using multiple forms of representations to make sense of and understand mathematics.
- PRI 3: Describe and justify mathematical understandings by constructing viable arguments, critiquing the reasoning of others and engaging in meaningful mathematical discourse.
- PRI 5: Use appropriate tools strategically to support thinking and problem solving.
- PRI 7: Look for and make use of patterns and structure.
- PRI 10: Reflect on mistakes and misconceptions to improve mathematical understanding.

Sequence of Instruction

Activities Checklist

Engage

PRI 1  
PRI 2

Project the **concert seating** picture below as students enter the room.

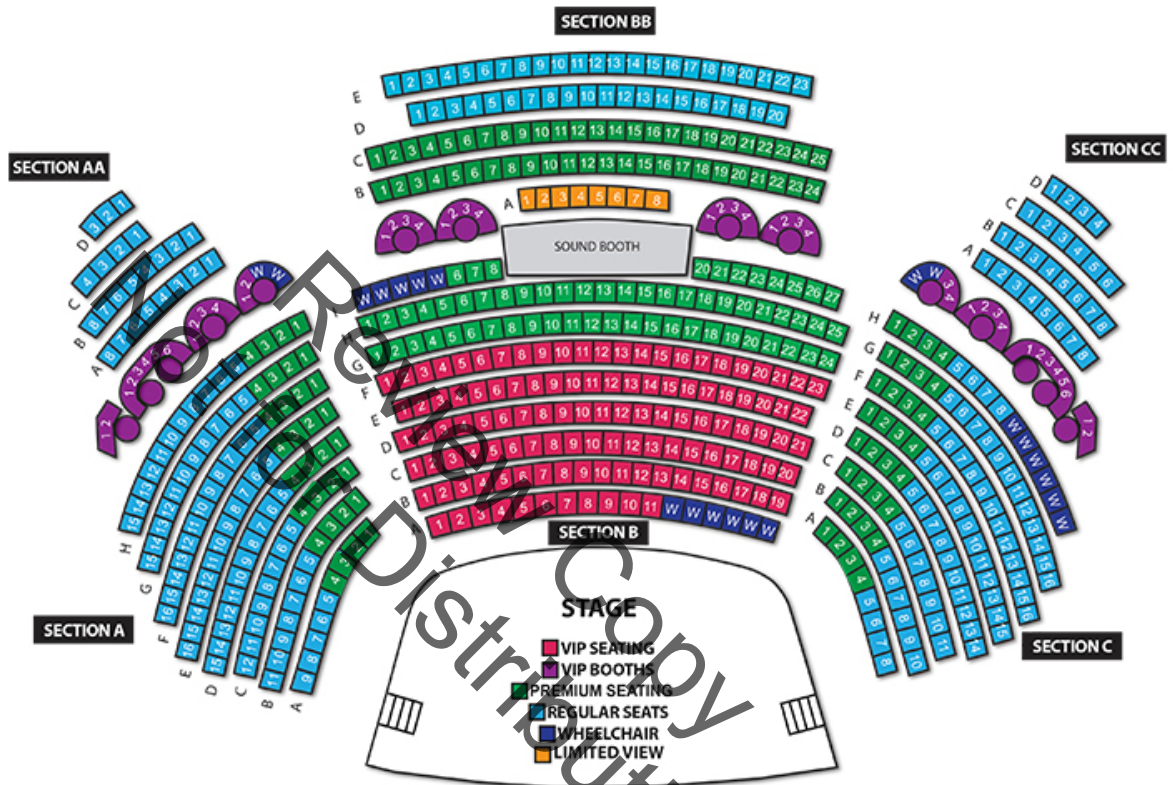

Write the following question on the board: “Have you ever attended an event that requires ticketed seating?” Provide a way for students to indicate “yes” or “no” that can be easily seen by the entire class. Once everyone has casted their vote, ask “What fraction of students have attended a ticketed seating event? What fraction have not? If we add both of those fractions together what should the result be?” These questions are an attempt to activate what was learned in the previous lesson to today’s lesson.

“Although you may not have used pattern blocks as we did in the previous lesson in some time, you may want to go to a concert or event that requires ticketed seating. This is a seating chart for a concert venue which looks a lot like some of the mosaics you created last lesson. Without trying to count the seats, answer questions 1-3 (the estimate column) on Task #3 in your student manual. For the purposes of this activity we have combined the dark blue, purple, and yellow seating areas to identify “Special Seating”. Only display the chart for a short time to discourage students counting seats.

*Teacher’s Note: The picture was intentionally left out of the student manual to deter students from counting the seats and encourage estimation.*

INCLUDED IN THE STUDENT MANUAL

### Task #3: Fabricating Estimates

Refer to the stadium seating to answer the following questions. Do not attempt to count the seats and use simple fractions.

- |   | Estimate | □ | "Actual" |
|---|----------|---|----------|
| 1. About what fraction of the seating is light blue?  | _____    |   | _____    |
| 2. About what fraction represents the amount of green seats?                                | _____    |   | _____    |
| 3. Estimate the fraction representing red seats.  | _____    |   | _____    |
| 4. Estimate the fraction representing special seating (dark blue, purple and yellow) areas. | _____    |   | _____    |
| 5. Estimate the fraction representing VIP and wheelchair areas.                             | _____    |   | _____    |
| 6. Compare each of your estimates with the ones provided (<, >, =)                          | _____    |   | _____    |

7. Draw an area model in the spaces below to represent the comparison between each of your estimates and the ones provided.

(1)	(2)	(3)	(4)

7. (Line a)

---

(Line B)

---

## Explore

### PRI 7

Now that students have estimated fractional portions of the seating have them compare their estimates to the ones below. The fractions below are approximations of the fractional portions for the purpose of this lesson.

Light blue –  $\frac{4}{10}$

Green –  $\frac{3}{10}$

Red –  $\frac{2}{10}$

Special seating –  $\frac{1}{10}$

Have students answer question numbers 4 and 5 on Task #3 (shown on the previous page) by comparing their estimates to the ones provided.

Lead a whole class discussion allowing students to share how they represented their comparisons as an area model. Be sure to share and compare multiple student representations with different denominators, equivalent fractions, and different area model shapes (rectangles, circles, etc.)

Suggested questions to ask during the whole class discussion:

- “How do your estimates look alike/different than those shown?”
- “Did all of your estimates have the same denominators?”
- “Should they have had the same denominators? Why or why not?”
- “Can I place fractions with different denominators on the same line?”

Be sure to make the connection that just as when fractions are used to represent parts of a whole or parts of a set, the units (or denominator) must be alike when dividing into subunits/parts (numerator). This discussion is meant to get them thinking about when like denominators are wanted/needed. Students may elude to the fact that during the estimation activity, like denominators were not necessary to simply estimate, but if the desire was to check that all parts/sections had been included then the sum of the parts equaled the whole (denominator). Although this informally introduces the students to addition of fractions, we begin by exploring fractions as lengths.

#### **Whole class – Pose the challenge:**

“Now that you’ve estimated the fractional portions represented by each seat color as part of the whole seating area, those estimates are going to be used by a fabric company donating material to cover each of the seats for an upcoming event.”

Display the line shown below.



“Consider the length (shown as “line a” in Task #3 in your student manual) as the total amount of material that will be used to cover the seats. Use the line to show how the length of each color can be designated for the material order.”

Give students 1-2 minutes to make sense of the task and sketch their thoughts on the line in their manuals. Have students share with a shoulder partner before completing the line as a whole class. Encourage students to discover that the area model for any fraction can be communicated with a linear representation, such as on a number line.



## Explanation

### PRI 7

Some questions you may ask during the discussion:

“Is it okay if not all students placed the colors in the same order on the line?” *(Yes, commutative property of addition)*

“How is this line used differently than your typical number line?” *(This line segment was used to represent the whole, and the different colored sections represented the parts of that whole, whereas students are typically accustomed to using a number line to represent distance)*

*Sample answer below (answers and labeling will vary):*



Tell students that you would now like them to use “line b” in Task #3 to answer the following question:

- “How would the number line look if I changed the question to ask that you place the lengths of the materials on the number line where they belong?” Although representations may vary, a sample answer is provided below.

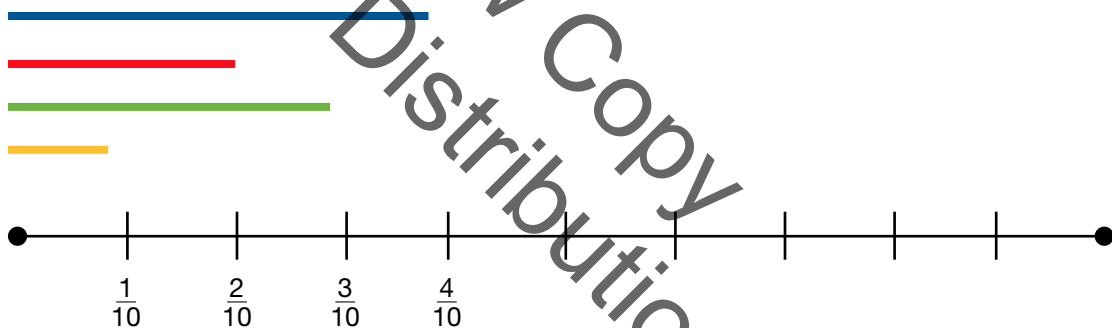

Lead a whole class discussion surrounding the difference between the two questions as well as their representations. The intent of the discussion is to create the connection, as well as the distinction, between representing fractional portions on a line to show a part to whole relationship (line 1) and using a number line to represent individual fractional lengths (line 2).

Some sample questions to use during this discussion:

- “Did the lengths/sections change?” *(No)*
- “If not, then why are the representations different?”
- “What did change?”

Explain to students that they will use fractions as length to complete Task #4.

**Practice Together / in Small Groups / Individually**

**PRI 5**

Instruct students to complete Task #4: Waiting in Line in the student manual. If Unifix cubes or Cuisenaire rods are available, allow students to use the manipulatives to compare lengths. If those are not available, then offer strips of paper and demonstrate how paper folding can be used to compare different fractional lengths.

Upon completion of the task, have students share with a partner to compare their answers. Be sure to explicitly state that the fraction model students have been exploring during this lesson is called the length or measurement model. The linear model of fractions is beneficial when partitioning or subdividing a line of specified length into fractional pieces.

INCLUDED IN THE STUDENT MANUAL

**Task #4: Waiting in Line**

You're attending a concert with five friends but each of you arrived at the venue at different times. The fractions below tell how much of the distance they have already moved since they got in line. (Think about fractions as area models if you need some help!)

You  $\frac{3}{4}$     Andrea  $\frac{1}{2}$     Bart  $\frac{4}{5}$     Camden  $\frac{7}{8}$     Drake  $\frac{3}{7}$     Ethan  $\frac{2}{3}$

1. a. Who do you know is not going to get in the gate first?

\_\_\_\_\_

b. How do you know?

\_\_\_\_\_

\_\_\_\_\_

3. Place each person on the number line below to show where they are between the start and finish.



Who is getting in the gate first?

\_\_\_\_\_

**Task #4: Waiting in Line (ANSWER KEY)**

1. a. Who do you know is not going to get in the gate first? *anyone but Camden*

b. How do you know? *Answers will vary.*

3. Place each person on the number line below to show where they are between the start and finish. *Approximation is acceptable for this activity, however all names should be placed in the relative position on the line.*



Who is getting in the gate first? *Camden*

## Evaluate Understanding

**PRI 3** While students are working independently on Task #4: Waiting in Line, pay close attention to their discussions and justifications. Try to identify students who are struggling, in order to clear up any issues before leaving class. If many students are having difficulty with ordering fractions on a line then a brief whole-class discussion may be necessary before they complete the closing activity.

## Closing Activity

**PRI 3** **I have...Who has...? Fractions as Area Models and Measures**

**PRI 10**

*Teacher's Note: Students will need room to line up against a wall or around the perimeter of the room. You may choose to conduct this entry activity in the hallway if more room is needed.*

Distribute "I have...Who has? Area Models and Measurements cards. Cards are at the end of this lesson.

Some students may receive two cards depending upon how many students are in the class. It is important to use all the cards in the set.

Explain that they will be playing "I have...Who has...?" with proper fractions. After each student reads the "I have" statement on the card, he/she will compare his/her area model with the others already in place and stand against the wall in one of the three groups creating an informal number line:

- a) Less than  $\frac{1}{2}$
- b) Equal to  $\frac{1}{2}$
- c) More than  $\frac{1}{2}$

*\*Students are not to read their "Who has...?" until they are positioned on the number line. Student discussion is encouraged if a student is having trouble getting positioned on the number line.*

*Teacher's Note: If students respond to the "I have..." statement with an equivalent fraction remind students that for this activity we want to use the fraction that expresses the actual part and whole relationship shown and not equivalent (simplified) forms. Students will be engaged in a more formal discussion about equivalence later in the lesson.*

Choose the student with the area model for  $\frac{1}{2}$  to go first, and have him/her say, "**My name is** (student name), and I have \_\_\_\_\_ (fraction that the area model on the top of the card represents)." Position the student with that card in the center of the wall as the anchor fraction. All other students will position themselves in relation to  $\frac{1}{2}$ . Have the student read "**Who has** (the fraction on the bottom of the card)?"

The student holding the card with the area model representing that fraction then responds with "**My name is** (student name), and I have \_\_\_\_\_ (fraction that the area model on the top of the card represents). He/she then positions himself/herself in relation to the student with the area model for  $\frac{1}{2}$ . Once positioned, the student then reads, "Who has (the fraction on the bottom of the card)?"

Every card in the set is connected to a card before it and a card after it. To keep the game moving at a quick pace, all students need to pay attention to every question that's asked.

Play continues in this fashion until all of the cards have been played. The game will end with the same student who started play.

As more students are added to the number line and students compare their area models with those being added to their groups, listen for justifications of placement.

If time allows once all students are positioned on the number line in their groups less than, greater than, or equal to one half have the students order themselves within their groups. Once the groups have ordered themselves, place all students back on the number line and have the class to assess their progress in ordering fractions as measures on a number line.

*Teacher's Note: As students are discussing, be sure to encourage proper terminology, such as "five ninths" instead of using the statements "five out of nine" (unless talking about ratios or probability) or "five over nine". This will encourage the concept that fractions are numbers just like 12 or 147.*

Lead a discussion about parts of a set by posing the following questions to each group:

Spiral review (parts of sets)

- In the set of cards less than  $\frac{1}{2}$ , what fraction represents the number of models that are blue or green? ( $\frac{2}{3}$  or 8 cards)
- In the set of cards equal to  $\frac{1}{2}$ , what fraction represents the number of models that are not blue? ( $\frac{1}{3}$  or 2 cards)
- In the set of cards greater than  $\frac{1}{2}$ , what fraction represents the number of models that are yellow ( $\frac{4}{11}$  or 4 cards)

### Independent Practice:

---

Fraction Feud (Illuminations) <https://illuminations.nctm.org/uploadedFiles/Content/Lessons/Resources/3-5/FractionFeud%20AS.pdf>

Fraction Feud Answer Key (Illuminations) <https://illuminations.nctm.org/uploadedFiles/Content/Lessons/Resources/3-5/FractionFeud%20AS.pdf>

### Resources/Instructional Materials Needed:

---

Task #3: Fabricating Estimates

Task #4: Waiting in Line

I have...Who has? Area Models and Measurement Cards

Crayons/markers







Fraction strips (optional)



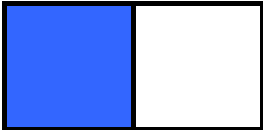
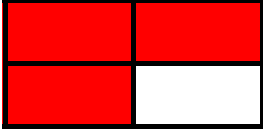

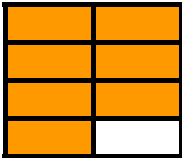
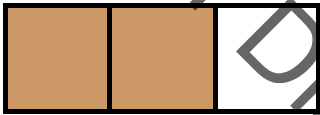
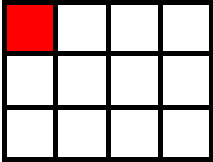
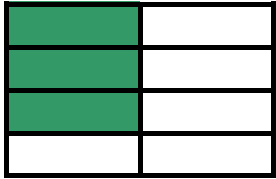

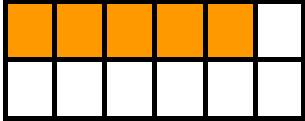
Cuisenaire rods (optional)



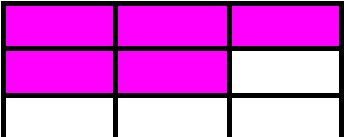

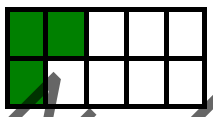
Unifix Cubes (optional)

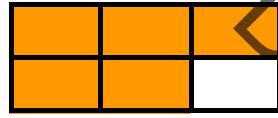
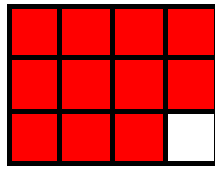
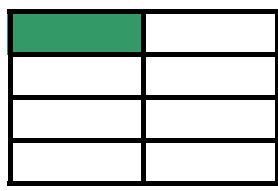
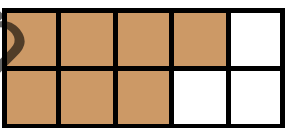
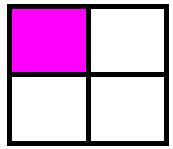
Fraction Feud Practice Sheet

Fraction Feud Answer Key

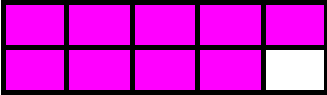
<p>I have </p> <p>Who has <math>\frac{3}{4}</math> ?</p>	<p>I have </p> <p>Who has <math>\frac{2}{5}</math> ?</p>
<p>I have </p> <p>Who has <math>\frac{7}{8}</math> ?</p>	<p>I have </p> <p>Who has <math>\frac{2}{3}</math> ?</p>
<p>I have </p> <p>Who has <math>\frac{1}{12}</math> ?</p>	<p>I have </p> <p>Who has <math>\frac{3}{8}</math> ?</p>
<p>I have </p> <p>Who has <math>\frac{4}{5}</math> ?</p>	<p>I have </p> <p>Who has <math>\frac{5}{12}</math> ?</p>
<p>I have </p> <p>Who has <math>\frac{2}{6}</math> ?</p>	<p>I have </p> <p>Who has <math>\frac{5}{9}</math> ?</p>

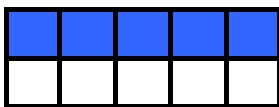
<p>I have </p> <p>Who has <math>\frac{4}{7}</math> ?</p>	<p>I have </p> <p>Who has <math>\frac{3}{10}</math> ?</p>
<p>I have </p> <p>Who has <math>\frac{1}{3}</math> ?</p>	<p>I have </p> <p>Who has <math>\frac{5}{6}</math> ?</p>
<p>I have </p> <p>Who has <math>\frac{11}{12}</math> ?</p>	<p>I have </p> <p>Who has <math>\frac{1}{8}</math> ?</p>
<p>I have </p> <p>Who has <math>\frac{7}{10}</math> ?</p>	<p>I have </p> <p>Who has <math>\frac{1}{4}</math> ?</p>
<p>I have </p> <p>Who has <math>\frac{2}{9}</math> ?</p>	<p>I have </p> <p>Who has <math>\frac{9}{10}</math> ?</p>

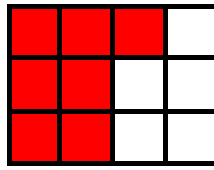
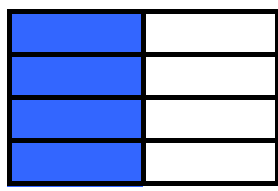
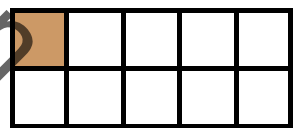
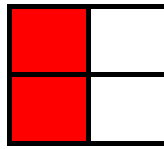
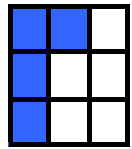
<p>I have </p> <p>Who has <math>\frac{7}{9}</math> ?</p>	<p>I have </p> <p>Who has <math>\frac{3}{5}</math> ?</p>
<p>I have </p> <p>Who has <math>\frac{5}{10}</math> ?</p>	<p>I have </p> <p>Who has <math>\frac{3}{6}</math> ?</p>
<p>I have </p> <p>Who has <math>\frac{7}{12}</math> ?</p>	<p>I have </p> <p>Who has <math>\frac{4}{8}</math> ?</p>
<p>I have </p> <p>Who has <math>\frac{1}{10}</math> ?</p>	<p>I have </p> <p>Who has <math>\frac{2}{4}</math> ?</p>
<p>I have </p> <p>Who has <math>\frac{4}{9}</math> ?</p>	<p>I have </p> <p>Who has <math>\frac{1}{2}</math> ?</p>

## Fractions

# Lesson 3 of 6

## Equivalent Fractions as a Result of Division

### Description:

---

Students will explore fractions as a result of division and use models to determine and compare equivalent fractions.

### College- and Career-Readiness Standards Addressed:

---

- NF.3 Interpret a fraction as division of the numerator by the denominator ( $\frac{a}{b} = a \div b$ ). Solve word problems involving division of whole numbers leading to answers in the form of fractions or mixed numbers, e.g., by using visual fraction models or equations to represent the problem. For example, interpret  $\frac{3}{4}$  as the result of dividing 3 by 4, noting that  $\frac{3}{4}$  multiplied by 4 equals 3, and that when 3 wholes are shared equally among 4 people each person has a share of size  $\frac{3}{4}$ . If 9 people want to share a 50-pound sack of rice equally by weight, how many pounds of rice should each person get? Between what two whole numbers does your answer lie?

### Process Readiness Indicator(s) Emphasized:

---

- PRI 1: Make sense of problems and persevere in solving through reasoning and exploration.
- PRI 3: Describe and justify mathematical understandings by constructing viable arguments, critiquing the reasoning of others and engaging in meaningful mathematical discourse.
- PRI 5: Use appropriate tools strategically to support thinking and problem solving.
- PRI 6: Attend to precision.
- PRI 7: Look for and make use of patterns and structure.
- PRI 8: Look for and express regularity in repeated reasoning.



## Engage

**PRI 1**  
**PRI 3**

### Introductory Activity: Waiting in Another Line

Explain to students that while they were standing in line at the concert there was a downpour and everyone ran for cover losing their place in line. As the venue director, in order to place everyone back in line randomly, you will deal two (2) playing cards to each student. Explain that jacks equal 11, queens equal 12, kings equal 13, and aces are one.

The card in the left hand represents their numerator. The card in the right hand represents their denominator. The fraction their cards create is the distance remaining between them and the concert entrance (classroom door). Just as they did in the closing activity in the last lesson with area models, students are to order themselves on the imaginary number line as they receive their cards. Encourage student conversation to assist one another in properly placing themselves as they add themselves to the number line.

Although this task is similar in nature to the “I have...Who has?” activity, now the denominators and numerators can range from 1-13 allowing for improper fractions increasing the difficulty of the activity. As students discuss where they belong on the line in relation to other numbers that are close to one another you may need to scaffold the experience by asking questions that encourage comparison of numbers using any of the models discussed in the past two lessons. This comparison leads to the discussion of fractions as a result of division.

Lead a whole class discussion asking the following questions:

- “How was this activity like the “I have...Who has?” activity?”
- “How was it different?”
- “Was this harder or easier? Why?”
- “If you had a numerator that was larger than the denominator, what was that fraction called?”
- “How did you decide where to place yourself on the number line?”
- “Which fraction do you feel is harder to place on the line, one with a larger denominator or an improper fraction? Why?”

As students share their thoughts surrounding their comfort level with fractions other than proper, remind them that all fractions begin from a whole and once the whole is identified it is much easier to compare a less common fraction to the numbers surrounding it. The idea of expressing fraction as a result of division is what they will be working on in this lesson.

## Explore

**PRI 1**  
**PRI 5**  
**PRI 6**

### Pair Activity: What's in the Deck?

Ask students to complete Task #5: What's in the Deck? Encourage students to use a blank piece of paper to represent an entire deck of playing cards and to use that rectangle to complete the table. They will use the three different representations to answer the questions about the fractional parts of a deck of cards. (if available, give each pair of students a deck of cards to manipulate during this activity or they can use Geoboards to represent areas and assist their problem solving)

*Note to the teacher:* Reference *Area* models as used in the "I have...Who has?" activity in Lesson 2. Reference *Set* models as used in Task #2, "Here's Your Part". Reference *Length* models as used in Task #4, Waiting in Line.

INCLUDED IN THE STUDENT MANUAL





#### Task #5: What's in the Deck

	Area	Set	Length	What fraction is represented?
1. What fraction of colors in a deck of cards is red?				
2. What fraction of suits in a deck of cards is spades?				
3. What fraction of the heart suit in a deck of cards is king(s)?				
4. What fraction of the heart suit in a deck of cards is face cards?				
5.				
6.				

Ask students to show how they would represent the following within the deck of cards using each of the fraction models: Area, Set, and Length. Ensure students use full sentences to explain.

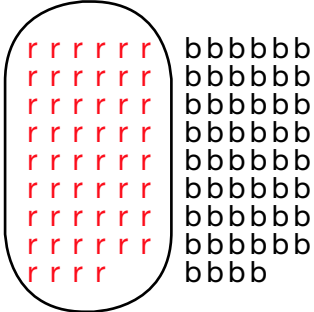
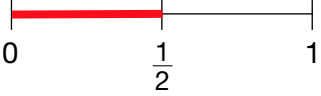
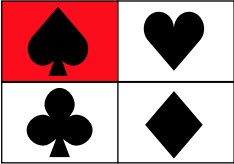
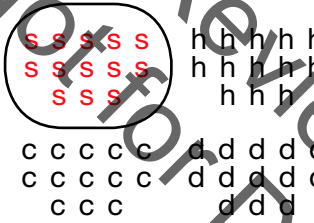
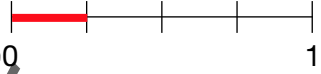
1. What fraction of colors in a deck of cards is red?
2. What fraction of suits in a deck of cards is spades?
3. What fraction of the heart suit in a deck of cards is kings?
4. What fraction of the heart suit in a deck of cards is face cards?

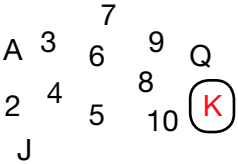
**Task #5: What's in the Deck? (ANSWER KEY)**

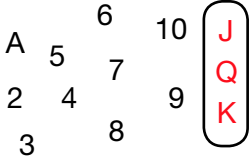
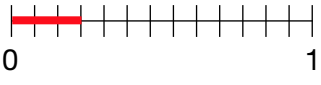
Area	Set	Length	What fraction is represented?
<p>1. What fraction of colors in a deck of cards is red?</p> 			<p><math>\frac{1}{2}</math> the colors in a deck is red.</p>
<p>2. What fraction of suits is a deck of cards is spades?</p> 			<p><math>\frac{1}{4}</math> of the suits in a deck is spades.</p>
<p>3. What fraction of the heart suit in a deck of cards is king(s)?</p> 			<p><math>\frac{1}{13}</math> of the heart suit is kings</p>
<p>4. What fraction of the heart suit in a deck of cards is face cards?</p> 			<p><math>\frac{3}{13}</math> of the hearts suit is face cards.</p>

## Explanation

---

- PRI 3** Allow students to compare their models with other student pairs. As you listen to conversations encourage the discussion of how each of the three models (area, set, length) best represents each set and why.
- Discuss how changing the questions about the deck changed the length, or whole, being represented although they all represent a part of the deck.
- Choose a sample of differing models to share and discuss with the whole class.

## Practice Together / in Small Groups / Individually

---

- PRI 3**  
**PRI 5** Ask students to think about how they could create a set of models to represent the number of face cards within an entire deck of cards in row #5 by iterating the models created in row #4. Although students are to create each model, ask them to choose the model that best represents that fraction or makes more sense to them. Encourage students to share their reasoning for choosing a particular model versus another. Students should have completed row #5 of *Task #5: What's in the Deck* by creating a model of  $\frac{12}{52}$  representing the number of face cards in a deck of playing cards. This iteration will be reflected upon in the lesson on adding fractions.
- Ask students to create a set of models to represent the number of face cards within four decks of cards in row #6 in the table. As students work within their pairs to iterate or partition the fractional portion of a deck, listen to their reasoning for beginning with one model versus another. If you notice students relying on one model versus the others encourage the use of the others, but be sure to ask why one would be more appropriate for certain situations. Attempt to gather a variety of samples, including both iteration and partitioning to display for reference during the classroom discussion. Students should create a model to show  $\frac{48}{208}$  to represent the number of face cards in four decks of playing cards.

## Evaluate Understanding

---

Lead a whole class discussion referring to the models created throughout the lesson and ask questions that will solidify the fact that although the models for the numbers  $\frac{3}{13}$ ,  $\frac{12}{52}$ , and  $\frac{48}{208}$  may have looked different, they all identify the same number or have the same value, therefore they are equivalent fractions.

## Closing Activity

---

- PRI 1**  
**PRI 6**  
**PRI 7**  
**PRI 8** Display and pose the challenge shown on the next page to the whole class:
- Using the whole numbers 1-9 once each, create and place 4 fractions on the number line in the correct order. (fractions B & C are equal)

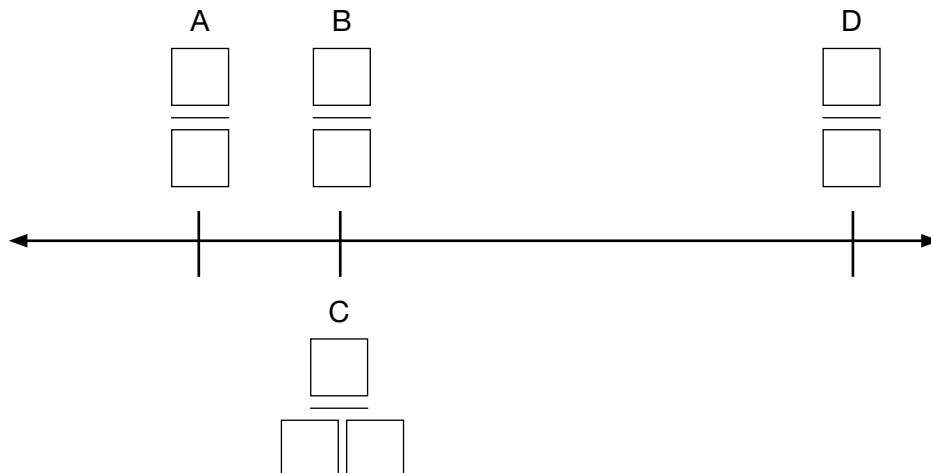

Source: <http://www.openmiddle.com/comparing-and-identifying-fractions-on-a-number-line/>

There are many possible answers. Here are a few:

$A = 1/7, B = 3/8, C = 9/24, D = 5/6$

$A = 1/5, B = 3/9, C = 8/24, D = 6/7$

$A = 5/8, B = 3/4, C = 9/12, D = 6/7$  (or  $D$  could be  $7/6$ )

**Independent Practice:**

Task #6: Humane Fractions (Adapted from Cindy's Cats Task) <http://www.noycefdn.org/documents/math/MARS/MARS2007/tft2007gr5-part3.pdf>

INCLUDED IN THE STUDENT MANUAL

**Task #6: Humane Fractions**

1. The Humane Society tracked the number of times the cats used the doggy/kitty door in a day. This weekend it was used 200 times. The cats used it  $\frac{1}{5}$  of the times and dogs used it  $\frac{8}{10}$  of the times. How many times did the cats use the door? How many times did dogs use the door? Choose and draw a model (area, set, length) and explain how you figured it out.
2. During a weekend adoption event,  $\frac{3}{8}$  of the animals adopted were birds,  $\frac{3}{16}$  were dogs. The remaining adoptions were cats. What fraction of the animals adopted were cats? Draw a different model than used in problem number one to show your thinking and explain how you found the answer.

Extension activity: Group game Fraction Spoons  
<http://games4gains.com/blogs/teaching-ideas/41499524-equivalent-fractions-game-of-spoons>

### Resources/Instructional Materials Needed:

---

Task #5: What's in the Deck

Task #6: Humane Fractions

One deck of cards per pair of students (optional)

Geoboards (optional)

Comparing and Identifying Fractions on a Number Line

<http://www.openmiddle.com/comparing-and-identifying-fractions-on-a-number-line/>

Review Copy  
Not for Distribution

## Fractions

# Lesson 4 of 6

## Adding and Subtracting Fractions

### Description:

---

Students will use concrete materials and drawings to model how fractional parts are combined or separated.

### College- and Career-Readiness Standards Addressed:

---

- NF.1 Add and subtract fractions with unlike denominators (including mixed numbers) by replacing given fractions with equivalent fractions in such a way as to produce an equivalent sum or difference of fractions with like denominators. For example,  $\frac{2}{3} + \frac{5}{4} = \frac{8}{12} + \frac{15}{12} = \frac{23}{12}$ . (In general,  $\frac{a}{b} + \frac{c}{d} = \frac{ad + bc}{bd}$ .)
- NF.2 Solve word problems involving addition and subtraction of fractions referring to the same whole, including cases of unlike denominators, e.g., by using visual fraction models or equations to represent the problem. Use benchmark fractions and number sense of fractions to estimate mentally and assess the reasonableness of answers. For example, recognize an incorrect result  $\frac{2}{4} + \frac{1}{2} = \frac{3}{7}$ , by observing that  $\frac{3}{7} < \frac{1}{2}$ .

### Process Readiness Indicator(s) Emphasized:

---

- PRI 1: Make sense of problems and persevere in solving through reasoning and exploration.
- PRI 2: Reason abstractly and quantitatively by using multiple forms of representations to make sense of and understand mathematics.
- PRI 3: Describe and justify mathematical understandings by constructing viable arguments, critiquing the reasoning of others and engaging in meaningful mathematical discourse.
- PRI 4: Contextualize mathematical ideas by connecting them to real-world situations. Model with mathematics.
- PRI 5: Use appropriate tools strategically to support thinking and problem solving.
- PRI 7: Look for and make use of patterns and structure.
- PRI 8: Look for and express regularity in repeated reasoning.

Sequence of  
Instruction

Activities Checklist

Engage

PRI 2  
PRI 7

Give students a blank sheet of paper. Have them fold it into thirds (tri-fold like a brochure). Label one third “area”, one third “set”, and the final third “length”.

Play Act One video Black Box2. <http://www.101qs.com/1772-black-box2--act-1>

Ask students to draw each of the representations of fraction models for all three problems to help them determine what will come out the other side of the black box. Have students share their representations with shoulder partners. Finally, have students write the equations represented by the Black Box problems.

Allow shoulder partner comparison of models before showing the Act 3 video. Lead a whole class discussion about what students noticed about the sums of the fractions in the video. Sample questions to ask:

- What was different between the first two problems and the third?
- What made it easier or harder to solve?
- What model did you begin with to make sense of the problem and why?
- What two fractions could go into the box to produce five twelfths?
- What would the result be if the following three fractions entered the black box? A third, a half, and a fourth?
- What would happen if five-sixths and one-half went into the box?
- What would happen if five-sixths and one-third went into the box?

Explain that today they will use the different fractional models to add and subtract fractions.

Explore

PRI 5

Ask students to record their answers to the following discussion on Task #7: Estimation Proclamation. This is a teacher guided task.

Explain that they are not to draw or calculate anything, only estimate the sum of the fractional expression that will be displayed. Encourage them to use whole numbers and easy fractions to estimate. Display each expression for 10 seconds before moving on to the next.

1.  $\frac{1}{3} + \frac{5}{6}$

2.  $\frac{3}{5} + \frac{4}{5} + \frac{1}{4}$

3.  $\frac{3}{4} - \frac{1}{3}$

4.  $\frac{7}{8} + \frac{3}{4}$

5.  $1\frac{1}{2} - \frac{5}{8}$



INCLUDED IN THE STUDENT MANUAL

### Task #7: Estimation Proclamation

Each fraction will be displayed for only 10 seconds. DO NOT draw or calculate, only estimate!

1. \_\_\_\_\_

2. \_\_\_\_\_

3. \_\_\_\_\_

4. \_\_\_\_\_

5. \_\_\_\_\_

*Teacher's note: This estimation activity can be differentiated by targeting student answers to the nearest whole or half if more scaffolding is required before moving on. If students display that a tougher challenge is needed, target student answers to the nearest fourth or eighth.*

Lead the discussion of their estimates either using the Whip Around strategy or shoulder partner discussions. The Whip Around strategy is described below.

Say "My estimate to problem number 1 is..." and point to the first person who states their estimate to the class and continue to "Whip" around the room, quickly selecting one student at a time to share their responses. This quick sharing out will allow students to share their responses as well as compare their estimates to others' and self-assess.

After each set of responses has been shared, ask which estimates they heard most often, and ask a few students to verbalize different strategies for estimating the sums and differences.

Now that students have had a chance to estimate the sums ask them to use any available manipulatives (rulers, dot or plain paper, Unifix cubes, fraction strips, etc.) to create a model for the sum in problem #1. Once students have had a chance to sketch their models, take a quick poll to see how many students chose which manipulative or model. Attempt to get a student to share how they used each model to solve the problem.

Emphasize the concept of inability to add the parts (numerators) of different wholes (denominators) by simply adding the numerators and denominators. Ask why this is. Remind students that in order to use the standard algorithm to add or subtract fractions, you must remember to add parts that are the same size or units. The following model practice will emphasize this notion.

## Explanation

**PRI 3**

### Using Area Models

**PRI 5**

Begin by drawing the area model for each fraction.

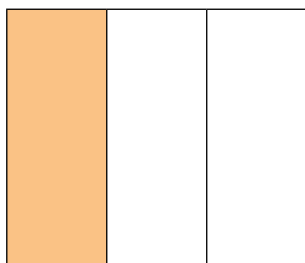

$$\frac{1}{3}$$

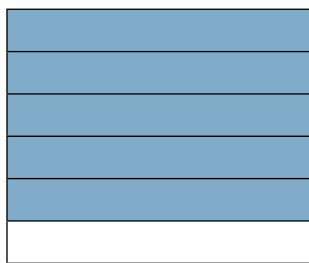

$$\frac{5}{6}$$

Since common units, or wholes, are needed in order to add the two numbers together I will subdivide each model by the other fractions unit as shown below.

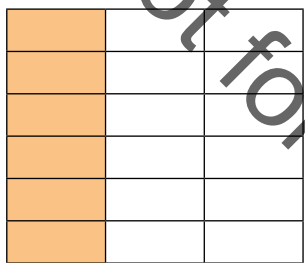

$$\frac{1}{3} = \frac{6}{18}$$

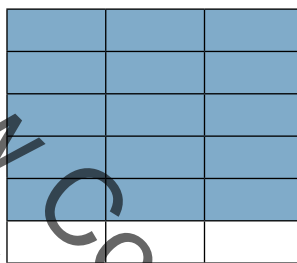

$$\frac{5}{6} = \frac{15}{18}$$

Now that both fractions are identified using the same unit, eighteenths, we can now add the parts.

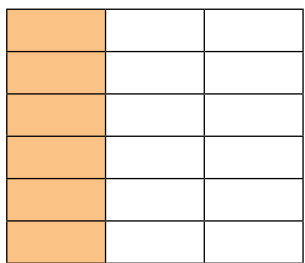

$$\frac{1}{3} = \frac{6}{18}$$

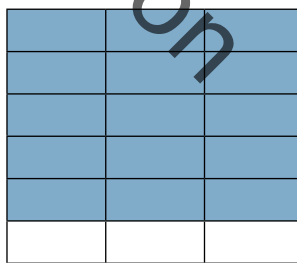

$$\frac{5}{6} = \frac{15}{18}$$

$$\frac{6}{18} + \frac{15}{18} = \frac{?}{?}$$

Ask students:

What will the numerator be?

What will the denominator be?

$$\frac{6}{18} + \frac{15}{18} = \frac{21}{18}$$

Use this opportunity to change the improper fraction shown to a mixed fraction along with its area model.

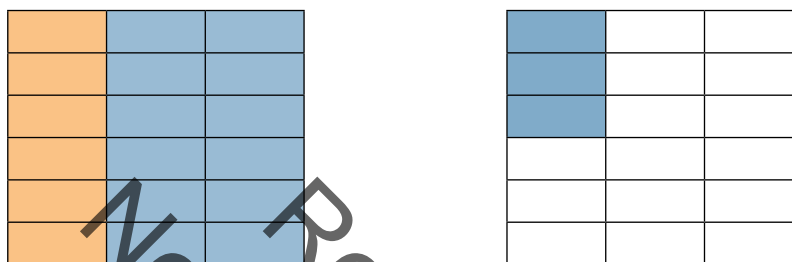

$$\frac{21}{18} = 1 \frac{3}{18}$$

Ask students to identify how to simplify the remaining fractional portion. Students may recognize that the numerator and denominator are divisible by 3, but how can you show it using the area model? Encourage students to explain how the equivalent fractions were formed by changing the parts of a set. In the areas below, the parts were grouped into 6 sets of 3 as opposed to the areas above which showed 18 groups of 1. This regrouping is how equivalent fractions are created by 'simplifying'.

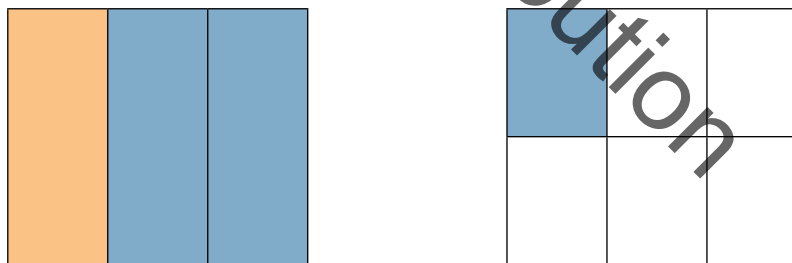

$$1 \frac{3}{18} = 1 \frac{1}{6}$$

Ask students to complete problems #2 ( $\frac{3}{5} + \frac{4}{5} + \frac{1}{4}$ ) and #3 ( $\frac{3}{4} - \frac{1}{3}$ ) using area models and then write the equations they have modeled. Share and compare with a shoulder partner.

### Modeling addition of fractional lengths using a ruler

You will now demonstrate how to use a ruler to add fractions. Begin by identifying the length of the first fraction.

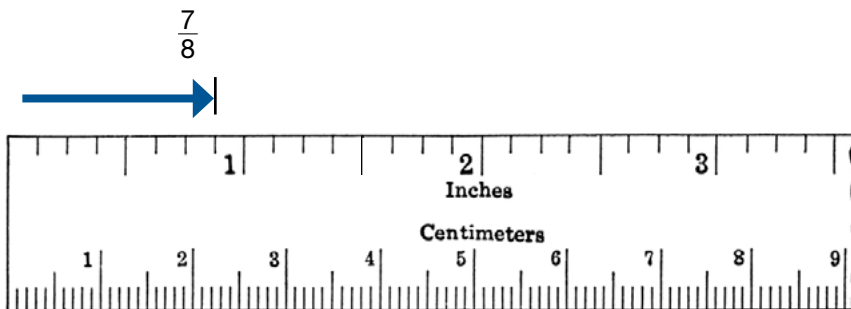

Begin measuring the length of the next fraction at the end of the first. The measurement at the end of the second fraction is the combined length, or sum of the fractions.

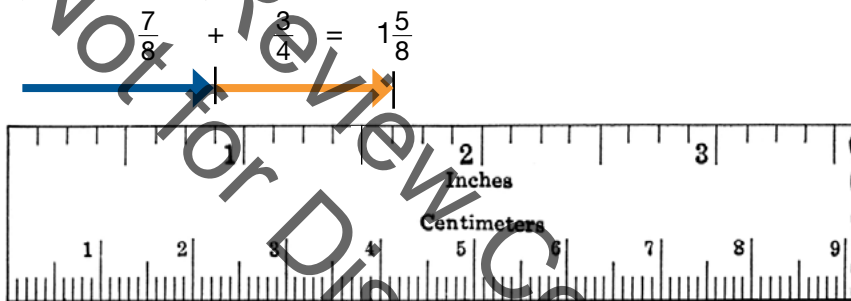

Lead a whole class discussion connecting the models to convention.

Sample questions to ask:

- How does this method differ from the area model method?
- Which one do you prefer and why?
- What patterns did you recognize with regard to the typical conventions of common denominators?

Close the discussion by making the connection between each of the models and how they lend themselves to creating common denominators.

### Practice Together / in Small Groups / Individually

**PRI 1**  
**PRI 4**

Assign Task #8: Salad Dressing either independently or in pairs. This Illustrative Mathematics task and solutions can be found at <https://www.illustrativemathematics.org/content-standards/5/NF/A/2/tasks/1172>.

INCLUDED IN THE STUDENT MANUAL

### Task #8: Salad Dressing

#### Aunt Barb's Salad Dressing Recipe

- $\frac{1}{3}$  cup olive oil
- $\frac{1}{6}$  cup balsamic vinegar
- a pinch of herbs
- a pinch of salt

Makes 6 servings

- a. How many cups of salad dressing will this recipe make? Write an equation to represent your thinking. Assume that the herbs and salt do not change the amount of dressing.
- b. If this recipe makes 6 servings, how much dressing would there be in one serving? Write a number sentence to represent your thinking.

### Evaluate Understanding

PRI 1  
PRI 2

Assign Task #9: The Swim Meet.

INCLUDED IN THE STUDENT MANUAL

### Task #9: The Swim Meet

Estimate your answers first. Draw a model to show your thinking and write the equation that goes with the problem.

1. Thunder was heard causing the swim meet to be stopped in the middle of a heat. The blue team completed  $3\frac{3}{4}$  laps. The red team completed  $2\frac{1}{6}$  laps. How many laps did they complete altogether?
2. Mr. Left and Mrs. Right took the 3 leftover pizzas home from the concession stand after a swim meet. He ate  $\frac{7}{8}$  of a pizza and she ate  $\frac{2}{6}$  of a pizza. How much pizza is left for their kids?

## Closing Activity

### PRI 3

Create “I have...Who has?” cards from the questions call and responses below. Again, as students read their “I have...” statement, reinforces ordering of fractions by having them line themselves up as an informal number line. Once all cards have been used, distribute blank cards to the remaining students.

*The directions for the blank cards can be differentiated.*

Lower level students: Each student is to create only the fraction to place themselves on the number line.

High level students: Each student is to create their own “I have...Who has?” cards to continue the game and place themselves on the number line.

Card No.	Front	Back
1	$3\frac{1}{2}$	I have $3\frac{1}{2}$ . Who has its double?
2	$\frac{1}{2}$	I have $\frac{1}{2}$ . Who has $\frac{1}{4}$ more?
3	$3\frac{3}{8}$	I have $3\frac{3}{8}$ . Who has 2 less?
4	2	I have 2. Who has $\frac{7}{8}$ more?
5	$4\frac{3}{4}$	I have $4\frac{3}{4}$ . Who has $\frac{3}{4}$ less?
6	$1\frac{1}{4}$	I have $1\frac{1}{4}$ . Who has $3\frac{1}{2}$ more?
7	$\frac{3}{8}$	I have $\frac{3}{8}$ . Who has $\frac{1}{8}$ more?
8	$6\frac{7}{8}$	I have $6\frac{7}{8}$ . Who has $6\frac{1}{2}$ less?
9	3	I have 3. Who has 3 more?
10	$1\frac{3}{8}$	I have $1\frac{3}{8}$ . Who has $\frac{5}{8}$ more?
11	4	I have 4. Who has $\frac{5}{8}$ less?
12	6	I have 6. Who has $2\frac{1}{2}$ less?
13	7	I have 7. Who has $\frac{1}{8}$ less?
14	$\frac{1}{8}$	I have $\frac{1}{8}$ . Who has $1\frac{1}{8}$ more?
15	$2\frac{7}{8}$	I have $2\frac{7}{8}$ . Who has $\frac{1}{8}$ more?
16	$\frac{3}{4}$	I have $\frac{3}{4}$ . Who has $\frac{5}{8}$ less?

### Independent Practice:

Choose either task to close this lesson. Both lessons are found at [www.openmiddle.com](http://www.openmiddle.com).

**Task A:** <http://www.openmiddle.com/adding-fractions/>

**Directions:** Make the smallest (or largest) sum by filling in the boxes using the whole numbers 1-9 no more than one time each.

$$\frac{\square}{\square} + \frac{\square}{\square}$$

Solution:  $\frac{9}{1} + \frac{8}{2}$  or  $\frac{8}{9} + \frac{6}{7}$

**Task B:** <http://www.openmiddle.com/adding-mixed-numbers/>

**Directions:** Make the largest sum by filling in the boxes using the whole numbers 1-9 no more than one time each.

$$\frac{\square}{\square} + \frac{\square}{\square}$$

Solution: The best I have found is  $9\frac{6}{7} + 8\frac{4}{5}$  or  $9\frac{4}{5} + 8\frac{6}{7}$ . Otherwise  $9\frac{8}{1} + 7\frac{6}{2}$  or  $9\frac{6}{2} + 7\frac{8}{1}$  would be best, assuming improper fractions could be allowed.

### Resources/Instructional Materials Needed:

Task #7: Estimation Proclamation

Task #8: Salad Dressing

Task #9: The Swim Meet

Ruler

Unifix cubes

Dot paper

Fraction Strips

## Fractions

# Lesson 5 of 6

## Multiplying and Dividing Fractions

### Description:

Students will use models to explore multiplication and division of fractions.

### College- and Career-Readiness Standards Addressed:

- NF.5 Interpret multiplication as scaling (resizing), by:
  - Comparing the size of a product to the size of one factor on the basis of the size of the other factor, without performing the indicated multiplication.
  - Explaining why multiplying a given number by a fraction greater than 1 results in a product greater than the given number (recognizing multiplication by whole numbers greater than 1 as a familiar case); explaining why multiplying a given number by a fraction less than 1 results in a product smaller than the given number; and relating the principle of fraction equivalence  $\frac{a}{b} = \frac{(n \times a)}{(n \times b)}$  to the effect of multiplying  $\frac{a}{b}$  by 1.
- NF.6 Solve real world problems involving multiplication of fractions and mixed numbers, e.g., by using visual fraction models or equations to represent the problem. For example, create a story context for  $(\frac{2}{3}) \div (\frac{3}{4})$  and use a visual fraction model to show the quotient; use the relationship between multiplication and division to explain that  $(\frac{2}{3}) \div (\frac{3}{4}) = \frac{8}{9}$  because  $\frac{3}{4}$  of  $\frac{8}{9}$  is  $\frac{2}{3}$ . (In general,  $(\frac{a}{b}) \div (\frac{c}{d}) = \frac{ad}{bc}$ .) How much chocolate will each person get if 3 people share  $\frac{1}{2}$  lb of chocolate equally? How many  $\frac{3}{4}$  cup servings are in  $\frac{2}{3}$  of a cup of yogurt? How wide is a rectangular strip of land with length  $\frac{3}{4}$  mi and area  $\frac{1}{2}$  square mi?
- NF.7 Apply and extend previous understandings of division to divide unit fractions by whole numbers and whole numbers by unit fractions.
- NS.3 Apply and extend previous understandings of multiplication and division and of fractions to multiply and divide rational numbers.

### Process Readiness Indicator(s) Emphasized:

- PRI 1: Make sense of problems and persevere in solving through reasoning and exploration.
- PRI 3: Describe and justify mathematical understandings by constructing viable arguments, critiquing the reasoning of others and engaging in meaningful mathematical discourse.
- PRI 5: Use appropriate tools strategically to support thinking and problem solving.
- PRI 9: Demonstrate flexible use of strategies and methods while reflecting on which procedures seem to work best for specific types of problems.
- PRI 10: Reflect on mistakes and misconceptions to improve mathematical understanding.



Sequence of Instruction

Activities Checklist

Engage

PRI 1  
PRI 5

Assign students Task #10: Desmos Number Sense – Multiplying Fractions. This activity was created from the interactive activity that can be found at <https://teacher.desmos.com/activitybuilder/custom/560411737786ed1a065481f3>.

Teacher Note: Task #10 was created to be used in conjunction with the interactive activity found at <https://teacher.desmos.com/activitybuilder/custom/560411737786ed1a065481f3>. If students have access to technology to complete the activity online independently, the teacher will have to click the blue “Start a New Session” button found at the link provided and provide students with the class code found on the left side of the screen. If students do not have access to complete the online activity independently, the teacher can project the “Student Screen Preview” found in the upper right corner of the screen and allow students to answer the questions as they complete the activity as a whole class.

INCLUDED IN THE STUDENT MANUAL

**Task #10: Desmos Number Sense: Multiplying and Dividing Fractions**

1. Show problem #1

a. What do you notice? How would you begin?

b. Identify the location representing  $\frac{1}{2}$  of 30



c. Write an equivalent expression showing the division performed

2. Show problem #2

a. How is this problem different from the first?

b. Identify the location representing  $\frac{3}{2}$  of 30

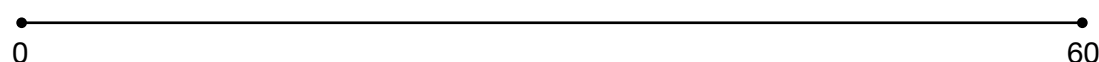

c. Write an equivalent expression showing the division performed

3. Show problem #3

a. How is this problem different from the last two? What makes it seem more difficult/easier?

b. Identify the location representing  $-\frac{1}{3}$  of 21

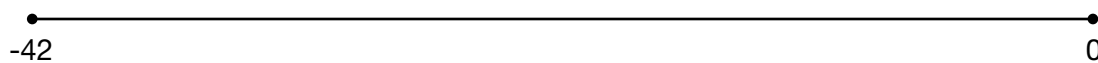

c. Write an equivalent expression showing the division performed.

---

4. Show problem #4

---

a. How would you use subdivision to help you solve this problem?

---

b. Identify the location representing  $-\frac{3}{5}$  of 45

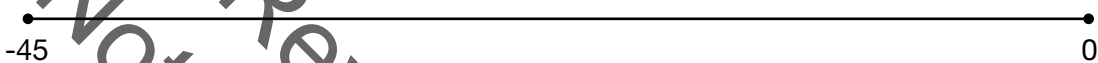

c. Write an equivalent expression showing the division performed

---

5. Show problem #5

---

a. What is different about the information given in this problem?

---

b. Identify the location representing  $\frac{1}{4}$  of -20



c. Write an equivalent expression showing the division performed

---

6. Show problem #6

---

a. How can you use this answer to check your answer to number 5?

---

b. Identify the location representing  $\frac{5}{4}$  of -20

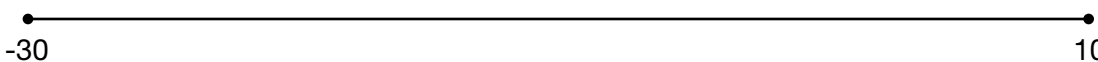

c. Write an equivalent expression showing the division performed

---

## Explore

Now that students have shared what they noticed and their thoughts on how to get started, allow students to identify the fractions in Task #10 on the number line. This activity builds upon the intuitive nature to use a number line by partitioning or subdividing to identify the location of the fraction. As students are constructing their responses, look for and listen to their reasoning as they work through parts 'b' and 'c' of each problem. Students are asked to communicate their number sense in part 'c' of each problem by constructing equivalent expressions to connect the multiplication and division of fractions.

*\*Students may complete this portion of the activity online.*

## Explanation

### PRI 10

Now that students have used the number lines to identify the location of the fraction, they will now use area and set models to extend their thinking.

Lead a discussion about number one and what the question is asking them to do. Ask if they would be more comfortable using the area or set representations of fractions to identify the location on the number line. Which would they have done first?

Below is a simple representation of the thought process your students may go through in order to solve the problem.

The work shown below is that of a student as he worked through all three parts (a, b, c) of problem 1.

1. What do you notice? *The number line is labeled from 0 to 60 but the problem is asking about a part of 30*

### PRI 3 PRI 9

How would you begin? *I would start by figuring out what I need to find in this problem, which is the point on the line that shows  $\frac{1}{2}$  of 30.*

*This student started the problem solving process by drawing a rectangle and labeling it as "30" to represent the whole as 30.*

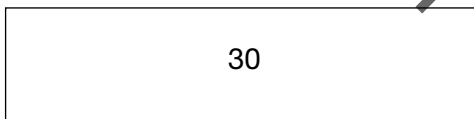

The student then divided the whole of thirty into 2 parts.



The student then added counters within the areas shifting to the set model of the fraction.

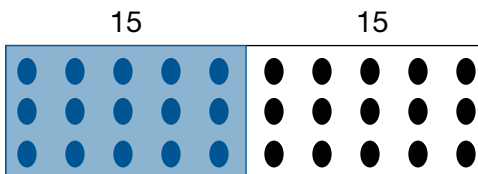

Once the student identified that  $\frac{1}{2}$  of 30 was 15 he then shifted to the length model to show his thinking on a number line.

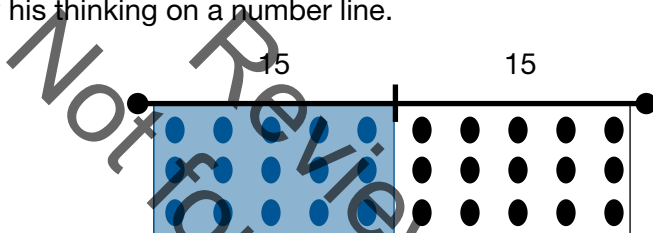

He then positioned the line segment onto the one provided in the problem.



To respond to question c, the student recognized that the location identified  $\frac{1}{4}$  of 60 which led to his answer  $\frac{60}{4}$  showing his understanding of fractions as a result of division. The teacher asked if he could create a multiplication problem from the expression he created. The student stated, "If one half of 30 is the same as  $\frac{30}{2}$ , then one-fourth of 60 should be the same of  $\frac{60}{4}$ ."

Note that the progression of thought shown above is not the only way to solve the problem, but it does exhibit that the student is comfortable with all three fractional representations they have used throughout the unit. As you discuss with your students their thought processes in solving this type of problem it is also important to ask students to verbalize what the problem is asking them to do. Students often struggle with fractional reasoning because they misunderstand what the problem is asking them to find.

To build upon student understanding of using area models, ask students to complete Task #11: Using Rectangles for Multiplying and Dividing Fractions independently. These problems came from the task found at [http://www.uen.org/Lessonplan/downloadFile.cgi?file=23394-2-29223-Using\\_Rectangles.pdf&filename=Using\\_Rectangles.pdf](http://www.uen.org/Lessonplan/downloadFile.cgi?file=23394-2-29223-Using_Rectangles.pdf&filename=Using_Rectangles.pdf)

INCLUDED IN THE STUDENT MANUAL

**Task #11: Using Rectangles for Multiplying and Dividing Fractions**

Shade the rectangle(s) to show each problem, and then use mathematics symbols to show the algorithms for multiplying and dividing.

1a.  $\frac{1}{4} \times 3$

1b.  $\frac{3}{4} \div \frac{1}{4}$

(How much is \_\_\_\_\_  
added \_\_\_\_\_ times?)

(How many times can \_\_\_\_\_  
be subtracted from \_\_\_\_\_ ?)

Students have not been formally instructed how to use areas to multiply and divide at this point in the unit. This part of the lesson is meant to give them the opportunity to make sense of what fraction problems are asking them to do and how it can be represented with areas. Once students have had the opportunity to complete the task, have students share their solutions and how they found them with a shoulder partner before discussing their methods in a whole class discussion.

**Practice Together / in Small Groups / Individually**

**PRI 5**  
**PRI 9**

Students will now solve multiplication and division problems using their understanding of areas and lengths of fractions.

Assign students Task #12: Using Fraction Tiles for Multiplying and Dividing Fractions to complete in pairs. More problems can be found at [http://www.uen.org/Lessonplan/downloadFile.cgi?file=23394-2-29222-Using\\_Fraction\\_Tiles.pdf&filename=Using\\_Fraction\\_Tiles.pdf](http://www.uen.org/Lessonplan/downloadFile.cgi?file=23394-2-29222-Using_Fraction_Tiles.pdf&filename=Using_Fraction_Tiles.pdf)

INCLUDED IN THE STUDENT MANUAL

**Task #12: Using Fraction Tiles for Multiplying and Dividing Fractions**

Use Fraction Tiles, sketches, mathematics symbols, and words to model each problem. Write words in the blank parentheses to represent those problems.

1a.  $\frac{1}{4} \times 3$  (How much is \_\_\_\_\_ added \_\_\_\_\_ times?)

1b.  $\frac{3}{4} \div \frac{1}{4}$  (How many times can \_\_\_\_\_ be subtracted from \_\_\_\_\_ ?)

## Evaluate Understanding

**PRI 5**  
**PRI 9**

Assign students Task #13: Multiplying and Dividing Fractions on a Number Line for independent completion or as homework. More problems can be found at [http://www.uen.org/Lessonplan/downloadFile.cgi?file=23394-2-29681-multiplying\\_dividing.pdf&filename=multiplying\\_dividing.pdf](http://www.uen.org/Lessonplan/downloadFile.cgi?file=23394-2-29681-multiplying_dividing.pdf&filename=multiplying_dividing.pdf).

INCLUDED IN THE STUDENT MANUAL

### Task #13: Multiplying and Dividing Fractions on a Number Line

Place a large point on the number line to represent the first number in each problem. Shade the number line to model the problem and show the answer. Then, use math symbols to set up the problem and find the answer.

1.  $\frac{1}{3} \times 3$  

How much is  $\frac{1}{3}$  added three times?

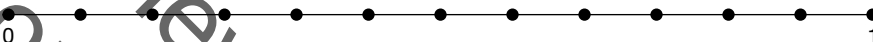
2.  $\frac{1}{3} \times \frac{1}{4}$  

How much is  $\frac{1}{3}$  added  $\frac{1}{4}$  time?

3.  $\frac{5}{6} \times \frac{1}{2}$  

How much is  $\frac{5}{6}$  added  $\frac{1}{2}$  time?

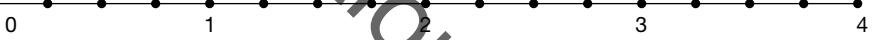
4.  $1\frac{1}{2} \times 1\frac{1}{2}$  

How much is  $2\frac{1}{2}$  added  $1\frac{1}{2}$  times?

## Closing Activity

**PRI 5**  
**PRI 9**

This is the final lesson before the Formative Assessment Lesson: Interpreting Multiplication and Division, so students will play a final round of “I have...Who has” Fraction Review. Cards are provided on the next pages.

10	$\frac{1}{8}$ of 16	2	Which is bigger $\frac{1}{4}$ or $\frac{1}{8}$ ?
$\frac{1}{4}$	$\frac{1}{4}$ of 16	4	$\frac{1}{2}$ of 16
8	Which is bigger $\frac{1}{2}$ or $\frac{1}{3}$ ?	$\frac{1}{2}$	Is $\frac{4}{4}$ the same as 1 whole? True or false?
True	$\frac{1}{2}$ of 24	12	$\frac{1}{8}$ of 24
3	If I have a cake with 16 slices and ate $\frac{1}{8}$ of it. How many slices do I have left?	14	Another fraction that equals $\frac{1}{2}$ with a denominator of 4
$\frac{2}{4}$	I ate $\frac{5}{8}$ of my chocolate bar. What fraction haven't I eaten?	$\frac{3}{8}$	$\frac{1}{4}$ of 20
5	Which is smaller $\frac{1}{8}$ or $\frac{1}{16}$ ?	$\frac{1}{16}$	I have $\frac{7}{8}$ of a cake left. What fraction have I eaten?
$\frac{1}{8}$	$\frac{1}{4}$ the same as $\frac{1}{8}$ . True or false?	False	Another fraction that equals a $\frac{1}{2}$ with a denominator of 8
$\frac{4}{8}$	$\frac{1}{2}$ of 32	16	$\frac{1}{4}$ of 24
6	If I have eaten $\frac{1}{4}$ of a pizza. What fraction is left?	$\frac{3}{4}$	$\frac{1}{2}$ of \$2.00
\$1	$\frac{1}{4}$ of 80c	20c	Another fraction that equals a whole with a denominator of 2
$\frac{2}{2}$	Which is smaller $\frac{2}{8}$ or $\frac{3}{8}$ ?	$\frac{2}{8}$	Another fraction that equals a whole with a denominator of 4
$\frac{4}{4}$	Which is bigger $\frac{1}{4}$ or $\frac{1}{3}$ ?	$\frac{1}{3}$	$\frac{1}{2}$ of 20

### Independent Practice:

---

Numerous opportunities to apply and extend understanding of multiplication and division are available here <https://www.illustrativemathematics.org/content-standards/6/>

### Resources/Instructional Materials Needed:

---

Task #10: Desmos Number Sense: Multiplying and Dividing Fractions

Task #11: Using Rectangles for Multiplying and Dividing Fractions

Task #12: Using Fraction Tiles for Multiplying and Dividing Fractions

Task #13: Multiplying and Dividing Fractions on a Number Line

I have...Who has? Fraction Review cards

Review Copy  
Not for Distribution



## Fractions

# Lesson 6 of 6

## Formative Assessment Lesson: Interpreting Multiplication and Division

### Description:

---

This lesson is designed to help students to interpret the meaning of multiplication and division with fractions using area models.

### College- and Career-Readiness Standards Addressed:

---

- NS.1 Interpret and compute quotients of fractions, and solve word problems involving division of fractions
- NS.3 Apply and extend previous understandings of multiplication and division and of fractions to multiply and divide rational numbers.

### Process Readiness Indicator(s) Emphasized:

---

- PRI 1: Make sense of problems and persevere in solving through reasoning and exploration.
- PRI 2: Reason abstractly and quantitatively by using multiple forms of representations to make sense of and understand mathematics.
- PRI 3: Describe and justify mathematical understandings by constructing viable arguments, critiquing the reasoning of others and engaging in meaningful mathematical discourse.
- PRI 4: Contextualize mathematical ideas by connecting them to real-world situations. Model with mathematics.
- PRI 5: Use appropriate tools strategically to support thinking and problem solving.
- PRI 6: Attend to precision.
- PRI 7: Look for and make use of patterns and structure.
- PRI 9: Demonstrate flexible use of strategies and methods while reflecting on which procedures seem to work best for specific types of problems.
- PRI 10: Reflect on mistakes and misconceptions to improve mathematical understanding.

The following *Formative Assessment Lesson* is a classroom-ready lesson included to help teachers assess and improve students' understanding of mathematical concepts and skills and their ability to use the mathematical process readiness indicators critical for college readiness.

Research has shown that formative assessment, as embodied in the following lesson, is a powerful way to improve student learning and performance. This approach first allows students to demonstrate their prior understandings and abilities in employing the mathematical processes, and then resolve their own difficulties and misconceptions through structured discussion. This results in more secure long-term learning, reducing the need for re-teaching that otherwise takes so much classroom time.

Many often ask, why don't students just remember the procedures they have been taught and practiced? The fact is, that approach works fine in the short term but, as every teacher knows, if procedural knowledge is not underpinned by conceptual understanding, students will quickly forget "how to do it."

Read more about the *Formative Assessment Lesson* rationale, structure, and philosophy using the *Brief Guide for Teachers and Administrators* that can be found at [http://map.mathshell.org/docs/map\\_cc\\_teacher\\_guide.pdf](http://map.mathshell.org/docs/map_cc_teacher_guide.pdf).

Review Copy  
Not for Distribution

---

## CONCEPT DEVELOPMENT

---

Mathematics Assessment Project  
**CLASSROOM CHALLENGES**  
A Formative Assessment Lesson

# Interpreting Multiplication and Division

Mathematics Assessment Resource Service  
University of Nottingham & UC Berkeley

For more details, visit: <http://map.mathshell.org>  
© 2015 MARS, Shell Center, University of Nottingham  
May be reproduced, unmodified, for non-commercial purposes under the Creative Commons license  
detailed at <http://creativecommons.org/licenses/by-nc-nd/3.0/> - all other rights reserved

## BEFORE THE LESSON

### Assessment task: *Multiplication and Division* (15 minutes)

Have students complete this task in class or for homework a few days before the formative assessment lesson. This will give you an opportunity to assess the work and to find out the kinds of difficulties students have with it. You should then be able to target your help more effectively in the subsequent lesson.

Explain what you would like students to do.

*Read this task carefully.*

*Spend a few minutes answering the questions on the sheet.*

*Fill in all the blank boxes.*

*In the second column, explain how to do the problem in words and draw a diagram to show this.*

*In the third column show a calculation to solve the problem.*

*In the final column show the numerical answer.*

*In questions 4 and 5 you have to make up the problems to match the calculations.*

*Do not be too concerned if you cannot finish everything. [Tomorrow] we will have a lesson on these ideas, which should help you to make further progress.*

Problem	Explain how to do the problem, and draw a diagram to help	Calculation	Answer
1 I buy three boxes of yogurt. Each box contains four yogurts. How many yogurts do I buy altogether?	Calculate three groups of four. 	$3 \times 4$ or $4 \times 3$	12
2 Two pizzas are shared equally among five people. How much does each person get?			
3 Max cuts a cake into three equal slices. He eats one half of a piece. What fraction of the cake does he eat?			
4 Make up this problem yourself!		$3 \div \frac{1}{2}$	
5 Make up this problem yourself!		$\frac{1}{2} \div \frac{1}{4}$	

### Assessing students' responses

Collect students' responses to the task. Make some notes on what their work reveals about their current levels of understanding and any difficulties they encounter.

We suggest that you do not score students' work. The research shows that this will be counter-productive as it will encourage students to compare their scores and distract their attention from what they can do to improve their mathematics.

Instead, help students make further progress by summarizing their difficulties as a series of questions. Some suggestions for these are given on the next page. These have been drawn from common difficulties observed in trials of this unit.

We suggest you make a list of your own questions, based on your students' work. We recommend you either:

- write one or two questions on each student's work, or
- give each student a printed version of your list of questions, and highlight appropriate questions for each student.

If you do not have time to do this, you could select a few questions that will be of help to the majority of students and write these on the board when you return the work to students in the follow-up lesson.

Common issues	Suggested questions and prompts
<p><b>Always divides larger numbers by smaller ones</b> For example: The student reverses the division and writes <math>5 \div 2</math> instead of <math>2 \div 5</math> (Q2).</p>	<ul style="list-style-type: none"> <li>• Can you ever divide a smaller number by a larger one? Show me an example.</li> <li>• What kind of answer do you get if you do this?</li> </ul>
<p><b>Always gives smaller answers following a division</b> For example: Student answers <math>1\frac{1}{2}</math> to <math>3 \div \frac{1}{2}</math> (Q4). Or: Student answers <math>\frac{1}{8}</math> to <math>\frac{1}{2} \div \frac{1}{4}</math> (Q5).</p>	<ul style="list-style-type: none"> <li>• How would you say these aloud: <math>3 \div \frac{1}{2}</math> ? <math>\frac{1}{2} \div \frac{1}{4}</math> ? Write down exactly what you would say in words.</li> <li>• Can you do this without using the words ‘divide’ or ‘share’? [E.g. ‘How many halves go into three?’]</li> </ul>
<p><b>Does not identify ‘of’ with multiply</b> For example: Student writes: <math>\frac{1}{3} \div \frac{1}{2}</math> for one half of one third (Q3).</p>	<ul style="list-style-type: none"> <li>• How would you write ‘one half of one fifth’ as a calculation?</li> <li>• Now work this out on a calculator.</li> <li>• Is your answer what you expected? Why?</li> </ul>
<p><b>Uses multiple calculations</b> For example: The student writes <math>1 \div 3 \div 2</math> (Q3).</p>	<ul style="list-style-type: none"> <li>• Can you write <math>1 \div 3 \div 2</math> as a one-step calculation?</li> </ul>
<p><b>Has difficulty expressing the structure using a diagram</b></p>	<ul style="list-style-type: none"> <li>• Can you show me what this calculation means using a diagram? [Supply any appropriate calculation.]</li> <li>• Your diagram does not have to be very artistic or accurate.</li> </ul>
<p><b>Completes the task correctly</b> The student needs an extension task.</p>	<ul style="list-style-type: none"> <li>• Make up some questions that would need some more difficult calculations. For example, can you make up a question where you would need to solve: <math>20 \div 2\frac{1}{4}</math> ?</li> </ul>

## SUGGESTED LESSON OUTLINE

Do not give out the students' assessment task at the beginning of this lesson in order to sort out the difficulties they encountered. This would reduce the opportunities for students to confront their misunderstandings for themselves during the collaborative activity. If you find most of your students had real difficulty with the assessment task then this lesson unit may not be appropriate.

### Whole-class introduction (20 minutes)

Throughout this introduction if students are struggling to answer the questions allow a few minutes to solve the questions individually, then ask them to discuss the question with a partner.

Give out the mini-whiteboards, pens, and erasers.

Show Slide P-1:

**What do these mean?**

$3 \times 6$	$6 \div 3$
$\frac{1}{3} \times 6$	$3 \div 6$

*Think about the meaning of each of these statements.*

*Try to think of more than one way to describe each statement.*

*Can you make a drawing to show one of them?*

Encourage alternative interpretations to emerge and do not correct them at this stage, even if answers are poorly expressed or incorrect. Students may use shading to indicate parts of their drawings and you could draw attention to this as a useful way to represent calculations. If students are struggling with these questions, encourage them to make up a real-life context for each calculation.

At this stage the purpose is to listen and record what students say. This should begin to engage some interest, as disagreements emerge. For example, for  $3 \div 6$  they might say:

*It's threes into six. (Incorrect.)*

*It's three split into six equal parts. (Correct.)*

Explain that some answers may be wrong. You will return to these later and reconsider them. It is not appropriate to lecture students on what is correct, as that will spoil the activities that are to follow. If possible, you could write students' interpretations on the board and leave them there to return to later.

Show the following calculation (See Slide P-2):  $6 \div \frac{1}{2}$ .

Ask the following questions:

*What does this statement mean? [6 divided by a half.]*

*Can you say this in a different way?*

*What is the answer?*

*Can you make up a real-life problem that requires this calculation?*

Students might begin by trying to remember the rules for dividing fractions.

They might read the calculation as ‘six shared by a half’. This description may be meaningless for them, so are unable to suggest a problem.

Alternatively, they may think that the answer is 3.

*How else can we read this calculation? [“How many halves are there in six?”]*

*Do you now know the answer? [12.]*

*Can you now make up a real-life problem that requires this calculation?*

*[“If I buy six pizzas and divide them each in half, how many slices will I end up with?”]*

### **Small-group work: matching Calculations to Words and Diagrams (20 minutes)**

Ask students to work in pairs or threes and give each small group a copy of *Card Set: Calculations* and *Card Set: Words and Diagrams*. These should be cut up. These are also shown on Slides P-3 and P-4. Make sure that blank paper is available in case students want to jot down ideas as they think.

Show Slide P-5 and introduce the process of working on the task:

#### **Matching Calculations and Words/Diagrams**

- Take turns to match a calculation to a word/diagram interpretation of that calculation.
- When a matching is made, explain how you can obtain the answer to the calculation using the diagram.
- Where a diagram does not exist, draw one of your own.

*You might find more than one calculation that matches a word/diagram or more than one word/diagram that matches a calculation. That is fine. Put the cards together however you think they go best.*

This process will encourage students to consider alternative ways of describing multiplication and division. Note that there are several alternative calculation cards that may be matched with some diagrams. This is intentional and should provide some interesting discussions among students.

While students discuss in small groups, you have two tasks: to note different student approaches to the task and to support student learning.

#### **Note different student approaches**

Which of the three representations do students find most difficult/easy to interpret: the calculations, the verbal description of the calculation or the diagram? Is this the same for each scenario or does it depend on the structure of the calculation? Can students explain the relationships between these different representations?

#### **Support student learning**

Try to support students’ thinking and reasoning, rather than prompting them to use any particular methods. Ask questions to help students clarify their thinking and explain their work:

*James, you have matched these two cards together. Can you explain why you think these cards match?*

*How does this diagram represent this calculation?*

You may find the questions in the *Common issues* table useful.

**Whole-class discussion: reviewing the learning (10 minutes)**

Now return to the original questions on the board. Ask learners to say which they now think are correct interpretations and ask them to give reasons.

Ask further questions that encourage students to generalize what they have learned to other calculations. For example, using mini-whiteboards, you could ask students to show answers to the following:

*How would you write these calculations in symbols:*

- *Twenty divided by nine?*
- *How many times does fifteen go into one hundred?*
- *What is one fifth of eighty?*
- *How many thirds are there in sixty?*
- *What is one half of one fifth?*
- *How many times does a third go into 12?*

The emphasis is on getting correct calculations, even if students are not able to work them out.

Avoid going from example to example without students following what other students are saying. Instead, encourage students to comment on what other students have just said:

*Did you understand what Qaylah just said?*

*Can you put it into your own words?*

*Do you agree with her? Why?*

**Extending the lesson over two days**

If you are taking two days to complete the unit then you may want to end the first lesson here. Ensure that students keep a record of the matches they have made and then at the start of the second day, give students time to review their matched cards before asking them to add in the word problems.

**Small-group work: matching Calculations, Interpretations, and Problems (20 minutes)**

Students remain in the same small groups. Give each group a copy of *Card Set: Pizza Problems* (cut up). These are also shown on projector Slide P-6. They will also need a large sheet of paper for making the poster, a glue stick, and some felt-tipped pens.

Display Slide P-7 of the projector resource and explain how students are to work together:

Working Together
<ul style="list-style-type: none"><li>• I want each group to make a poster to show each pizza problem card matched to an appropriate calculation.</li><li>• The calculation should show one correct way of solving the problem.</li><li>• Next to each pairing, explain why the cards match, using diagrams and/or words.</li><li>• You should also write an answer to the problem.</li></ul>

As students work together, watch carefully. If some struggle, ask them to try to explain what the calculations mean in words, as in the previous activity. Also, encourage students to draw their own diagrams to show the problem in a different way.



It is not necessary for every group to match up every problem. If you are short of time, you could ask students to choose four problems from *Card Set: Pizza Problems* and just match these ones.

**Whole-class discussion (20 minutes)**

Ask a representative from each group to choose a problem and calculation that they are sure go together and to explain why they go together to the rest of the class. Then ask the rest of the class if they agree or think they can improve on the explanation.

You might also ask a group that is unsure to talk about a problem or calculation that they cannot match.

Finally ask the class some further questions based on the pizza context.

Show me **a calculation** that matches each of these problems:

- If I share 2 pizzas equally between 4 people, how much pizza will each get? [ $2 \div 4$ .]
- There are eight pizzas at a party. One third are spicy. How many are spicy? [ $(1 \div 3) \times 8$ ]

Show me a pizza problem that would result in each of the following calculations:

$$2 + 8$$

$$\frac{1}{8} \div 2$$

$$\frac{1}{2} \times \frac{1}{8}$$

**Follow-up lesson: reviewing the assessment task (15 minutes)**

Give each student their original papers from the assessment task, *Multiplication and Division*. If you have not added questions to individual pieces of work then write your list of questions on the board. Students should select from this list only those questions they think are appropriate to their own work.

*First look at your original responses and the questions [on the board/written on your script.]  
Answer these questions and revise your response.*

Then give each student a copy of the review task, *Multiplication and Division (revisited)*.



*Now look at the new task sheet, *Multiplication and Division (revisited)*. Can you use what you have learned to answer these questions?*

Some teachers give this as homework.

**SOLUTIONS**



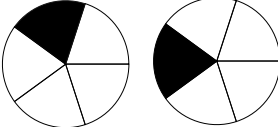
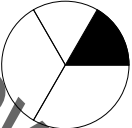

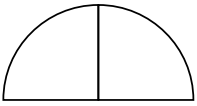
**Assessment task: *Multiplication and Division***

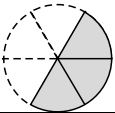

The shaded parts were given. The responses shown below are not the only ones possible.

	Problem	Explain how to do the problem, and draw a diagram to help.	Calculation	Answer
2	Two pizzas are shared equally among five people. How much does each person get?	<p>What is two divided by 5?</p> 	$2 \div 5$ or $\frac{1}{5} \times 2$ or $2 \times \frac{1}{5}$	$\frac{2}{5}$
3	Max cuts a cake into three equal slices. He eats one half of a slice. What fraction of the cake does he eat?	<p>What is one half of one third?</p> 	$\frac{1}{2} \times \frac{1}{3}$ or $\frac{1}{3} \times \frac{1}{2}$ or $\frac{1}{3} \div 2$	$\frac{1}{6}$
4	<i>Make up this problem yourself!</i> E.g. Three pizzas are each divided in half. How many slices are there?	<p>How many halves are there in 3?</p> 	$3 \div \frac{1}{2}$	6
5	<i>Make up this problem yourself!</i> E.g. A glass holds half a pint. A cup holds a quarter of a pint. How many cups can I fill from the glass?	<p>How many quarters are there in one half?</p> 	$\frac{1}{2} \div \frac{1}{4}$	2

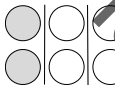
**Main lesson task**

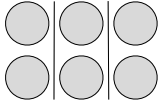
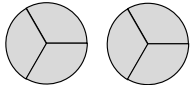

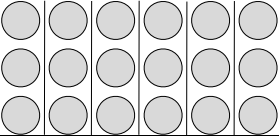
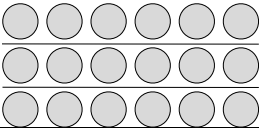
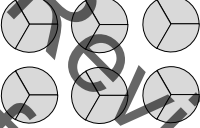
In many cases, more than one calculation can be matched with a diagram; only the most obvious answers are given in the table below. The possible equivalence of different calculations or different ‘words and diagrams’ cards is a useful discussion point. Students sometimes match cards based on the answer rather than on the calculation, and this may be something to draw out.

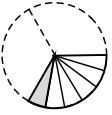
Calculations	Words and Diagrams	Pizza Problems
C3, C8, C9 and C14  $3 \times \frac{1}{6}$ $\frac{1}{6} \times 3$ $\frac{1}{6} \div \frac{1}{3}$ $3 \div 6$ These all have the answer $\frac{1}{2}$	W1 What is three groups of one sixth?  	P10 A whole pizza is divided into six equal slices. I eat three of these. What fraction of the whole pizza do I eat?
	W12 What fraction of one third is one sixth?  	P11 At a restaurant, each person is given one third of a whole pizza. I eat one sixth of a whole pizza. What fraction of my slice do I eat?
	W8 Three divided into six equal parts. How much is each part?  	P8 Three pizzas are divided equally among six people. What fraction of a whole pizza does each person get?
C1, C4, C6 and C11  $\frac{1}{3} \times 6$ $6 \times \frac{1}{3}$ $6 \div 3$ $\frac{1}{3} \div \frac{1}{6}$  These all have the answer 2	W2 What is one third of six?  	P6 There are six pizzas. One third are vegetarian. How many are vegetarian?
	W3 How many one-sixths are there in one third?  	P7 I cut a pizza into six equal slices. I then eat a third of the whole pizza. How many slices do I eat?
	W7 Six divided into three equal groups. How many in each group?  	P4 Six pizzas are placed into three boxes. The same number go into each box. How many is this?
	W6 Six groups of one third. How much altogether?  	P5 Six people are each given one third of a pizza to eat. How many whole pizzas are they given altogether?

<p>C5, C7 and C12</p> <p><math>3 \times 6</math></p> <p><math>6 \times 3</math></p> <p><math>6 \div \frac{1}{3}</math></p> <p>These all have the answer 18.</p>	<p>W4 Six groups of three. How many altogether?</p> 	<p>P2 Six boxes of pizza are delivered to a party. Each box contains three pizzas. How many pizzas are delivered altogether?</p>
	<p>W5 Three groups of six. How many altogether?</p> 	<p>P1 Three boxes of pizza are delivered to a party. Each box contains six pizzas. How many pizzas are delivered altogether?</p>
	<p>W10 Six divided into thirds. How many slices?</p> 	<p>P3 Six boxes, each containing one pizza, are delivered to a party. I divide each pizza into three equal slices. How many slices are there altogether?</p>
<p>C13, C2, C10</p> <p><math>\frac{1}{6} \times \frac{1}{3}</math></p> <p><math>\frac{1}{3} \times \frac{1}{6}</math></p> <p><math>\frac{1}{3} \div 6</math></p> <p>These all have the answer <math>\frac{1}{18}</math>.</p>	<p>W11 How much is one third of one sixth?</p> 	<p>P9 I am given one sixth of a pizza. I only eat one third of this slice. What fraction of the whole pizza do I eat?</p>
	<p>W9 How much is one sixth of one third?</p> 	<p>P12 I cut a pizza into three equal slices. I then eat a sixth of one slice. What fraction of the whole pizza do I eat?</p>

**Assessment task: Multiplication and Division (revisited)**

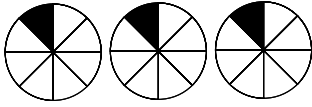
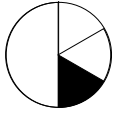
The shaded parts were given. The responses shown below are not the only ones possible.

	Problem	Explain how to do the problem, and draw a diagram to help.	Calculation	Answer
2	Three pizzas are shared equally among eight people. How much does each person get?	<p>Three divided by eight</p> 	$\frac{1}{8} \times 3$ or $3 \times \frac{1}{8}$ or $3 \div 8$	$\frac{3}{8}$
3	Max cuts a cake into two equal slices. He eats one third of a slice. What fraction of the whole cake does he eat?	<p>One third of one half</p> 	$\frac{1}{3} \times \frac{1}{2}$ or $\frac{1}{2} \times \frac{1}{3}$ or $\frac{1}{2} \div 3$	$\frac{1}{6}$
4	<p><i>Make up this problem yourself!</i>                      E.g. Four pizzas are each divided into thirds. How many slices are there?                      A jug holds four pints. A glass holds one third of a pint. How many glasses can I fill from the jug?</p>	<p>How many thirds in four?</p> 	$4 \div \frac{1}{3}$	12
5	<p><i>Make up this problem yourself!</i>                      E.g. A glass holds one third of a pint. A small cup holds a sixth of a pint. How many cups can I fill from the glass?</p>	<p>How many sixths are there in one third?</p> 	$\frac{1}{3} \div \frac{1}{6}$	2

## Multiplication and Division

Complete the gaps in the table. The first row has been done for you.  
The diagram should show the structure of the problem.  
The calculation should show a single multiplication or division.

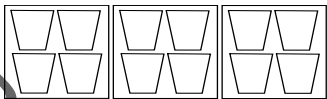
	Problem	Explain how to do the problem, and draw a diagram to help	Calculation	Answer
1	I buy three boxes of yogurt. Each box contains four yogurts. How many yogurts do I buy altogether?	Calculate three groups of four. 	$3 \times 4$ or $4 \times 3$	12
2	Two pizzas are shared equally among five people. How much does each person get?			
3	Max cuts a cake into three equal slices. He eats one half of a piece. What fraction of the cake does he eat?			
4	<i>Make up this problem yourself!</i>		$3 \div \frac{1}{2}$	
5	<i>Make up this problem yourself!</i>		$\frac{1}{2} \square \frac{1}{4}$	

### Card Set: Calculations

C1 $\frac{1}{3} \times 6$	C2 $\frac{1}{3} \times \frac{1}{6}$	C3 $3 \times \frac{1}{6}$
C4 $6 \div 3$	C5 $3 \times 6$	C6 $\frac{1}{3} \div \frac{1}{6}$
C7 $6 \div \frac{1}{3}$	C8 $\frac{1}{6} \times 3$	C9 $\frac{1}{6} \div \frac{1}{3}$
C10 $\frac{1}{3} \div 6$	C11 $6 \times \frac{1}{3}$	C12 $6 \times 3$
C13 $\frac{1}{6} \times \frac{1}{3}$	C14 $3 \div 6$	C15

### Card Set: Words and Diagrams

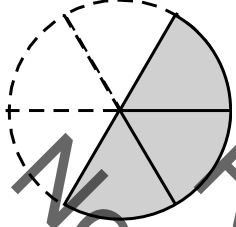
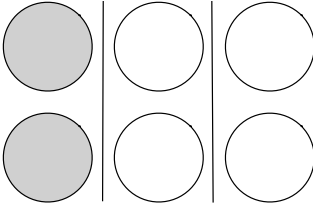
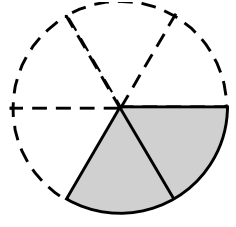
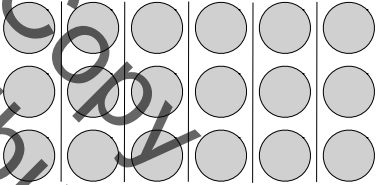
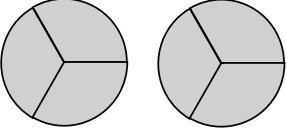
<p>W1 What is three groups of one sixth?</p> 	<p>W2 What is one third of six?</p> 
<p>W3 How many one-sixths are there in one third?</p> 	<p>W4 Six groups of three. How many altogether?</p> 
<p>W5</p>	<p>W6 Six groups of one third. How much altogether?</p> 

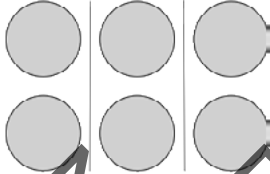
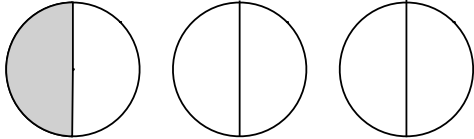
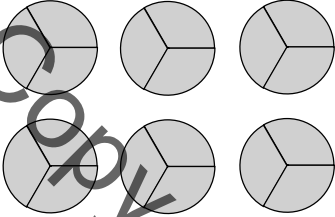
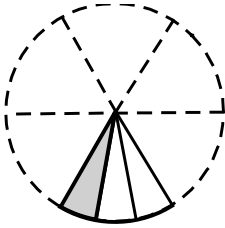
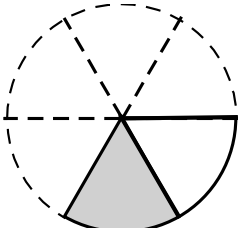

### Card Set: Words and Diagrams (continued)

<p>W7</p> <p>Six divided into three equal groups. How many in each group?</p> 	<p>W8</p> <p>Three divided into six equal parts. How much is each part?</p> 
<p>W9</p>	<p>W10</p> <p>Six divided into thirds. How many slices?</p> 
<p>W11</p> <p>How much is one third of one sixth?</p> 	<p>W12</p> <p>What fraction of one third is one sixth?</p> 

## Card Set: Pizza Problems

<p>P1</p> <p>Three boxes of pizza are delivered to a party. Each box contains six pizzas. How many pizzas are delivered altogether?</p>	<p>P2</p> <p>Six boxes of pizza are delivered to a party. Each box contains three pizzas. How many pizzas are delivered altogether?</p>
<p>P3</p> <p>Six boxes, each containing one pizza, are delivered to a party. I divide each pizza into three equal slices. How many slices are there altogether?</p>	<p>P4</p> <p>Six pizzas are placed in three boxes. The same number go into each box. How many is this?</p>
<p>P5</p> <p>Six people are each given one third of a pizza to eat. How many whole pizzas are they given altogether?</p>	<p>P6</p> <p>There are six pizzas. One third are vegetarian. How many are vegetarian?</p>
<p>P7</p> <p>I cut a pizza into six equal slices. I then eat a third of the whole pizza. How many slices do I eat?</p>	<p>P8</p> <p>Three pizzas are divided equally among six people. What fraction of a whole pizza does each person get?</p>
<p>P9</p> <p>I am given one sixth of a pizza. I eat only one third of this piece. What fraction of the whole pizza do I eat?</p>	<p>P10</p> <p>A whole pizza is divided into six equal slices. I eat three of these. What fraction of the whole pizza do I eat?</p>
<p>P11</p> <p>At a restaurant, each person is given one third of a whole pizza. I eat one sixth of a whole pizza. What fraction of my piece do I eat?</p>	<p>P12</p> <p>I cut a pizza into three equal slices. I then eat a sixth of one piece. What fraction of the whole pizza do I eat?</p>

## Multiplication and Division (revisited)

Complete the gaps in the table. The first row has been done for you.  
The diagram should show the structure of the problem.  
The calculation should show a single multiplication or division.

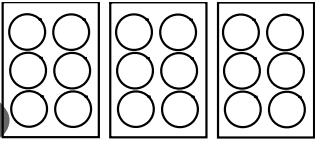
	Problem	Explain how to do the problem, and draw a diagram to help.	Calculation	Answer
1	I buy three boxes of golf balls. Each box contains six balls. How many balls do I buy altogether?	Calculate three groups of six. 	$3 \times 6$ or $6 \times 3$	18
2	Three pizzas are shared equally among eight people. How much does each person get?			
3	Max cuts a cake into two equal slices. He eats one third of a piece. What fraction of the whole cake does he eat?			
4	<i>Make up this problem yourself!</i>		$4 \div \frac{1}{3}$	
5	<i>Make up this problem yourself!</i>		$\frac{1}{3} \square \frac{1}{6}$	

**What do these mean?**

$$3 \times 6$$

$$1\frac{6}{3}$$

$$6 \div 3$$

$$3 \div 6$$

Review Copy  
Not for Distribution

**What does this mean?**

Review Copy  
Not for Distribution  
6  $\frac{1}{2}$  2

P-2



Interpreting Multiplication and Division

Projector Resources

# Calculations

C1	$1\frac{1}{3} \times 6$	C2	$1\frac{1}{3} \times \frac{1}{6}$	C3	$3 \times \frac{1}{6}$
C4	$6 \div 3$	C5	$3 \times 6$	C6	$1\frac{1}{3} \div \frac{1}{6}$
C7	$6 \div \frac{1}{3}$	C8	$1\frac{1}{6} \times 3$	C9	$1\frac{1}{6} \div \frac{1}{3}$
C10	$1\frac{1}{3} \div 6$	C11	$6 \times \frac{1}{3}$	C12	$6 \times 3$
C13	$1\frac{1}{6} \times \frac{1}{3}$	C14	$3 \div 6$	C15	

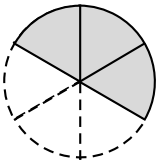
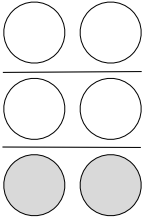
# Words and Diagrams

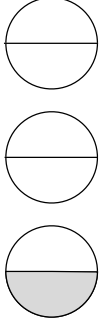
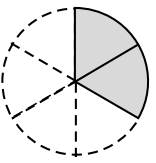
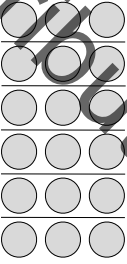
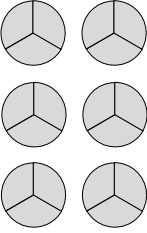
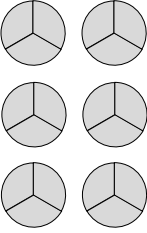
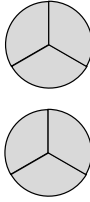
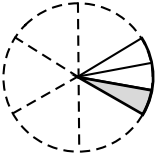
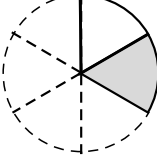
<p>W1 What is three groups of one sixth?</p> 	<p>W2 What is one third of six?</p> 	<p>W7 Six divided into three equal groups. How many in each group?</p> 	<p>W8 Three divided into six equal parts. How much is each part?</p> 
<p>W3 How many one-sixths are there in one third?</p> 	<p>W4 Six groups of three. How many altogether?</p> 	<p>W9 Six divided into thirds. How many slices?</p> 	<p>W10 Six divided into thirds. How many slices?</p> 
<p>W5</p>	<p>W6 Six groups of one third. How much altogether?</p> 	<p>W11 How much is one third of one sixth?</p> 	<p>W12 What fraction of one third is one sixth?</p> 

## Matching Calculations and Words/Diagrams

- Take turns to match a calculation to a word/diagram interpretation of that calculation.
- When a matching is made, explain how you can obtain the answer to the calculation using the diagram.
- Where a diagram does not exist, draw one of your own.



# Pizza Problems

<p>P1 Three boxes of pizza are delivered to a party. Each box contains six pizzas. How many pizzas are delivered altogether?</p>	<p>P2 Six boxes of pizza are delivered to a party. Each box contains three pizzas. How many pizzas are delivered altogether?</p>	<p>P3 Six boxes, each containing one pizza, are delivered to a party. I divide each pizza into three equal slices. How many slices are there altogether?</p>
<p>P4 Six pizzas are placed in three boxes. The same number go into each box. How many is this?</p>	<p>P5 Six people are each given one third of a pizza to eat. How many whole pizzas are they given altogether?</p>	<p>P6 There are six pizzas. One third are vegetarian. How many are vegetarian?</p>
<p>P7 I cut a pizza into six equal slices. I then eat a third of the whole pizza. How many slices do I eat?</p>	<p>P8 Three pizzas are divided equally among six people. What fraction of a whole pizza does each person get?</p>	<p>P9 I am given one sixth of a pizza. I eat only one third of this piece. What fraction of the whole pizza do I eat?</p>
<p>P10 A whole pizza is divided into six equal slices. I eat three of these. What fraction of the whole pizza do I eat?</p>	<p>P11 At a restaurant, each person is given one third of a whole pizza. I eat one sixth of a whole pizza. What fraction of my piece do I eat?</p>	<p>P12 I cut a pizza into three equal slices. I then eat a sixth of one piece. What fraction of the whole pizza do I eat?</p>

## Working Together

- I want each group to make a poster to show each pizza problem card matched to an appropriate calculation.
- The calculation should show one correct way of solving the problem.
- Next to each pairing, explain why the cards match, using diagrams and/or words.
- You should also write an answer to the problem.

## Mathematics Assessment Project **Classroom Challenges**

These materials were designed and developed by the  
Shell Center Team at the Center for Research in Mathematical Education  
University of Nottingham, England:

**Malcolm Swan,**  
**Nichola Clarke, Clare Dawson, Sheila Evans, Colin Foster, and Marie Joubert**  
with  
**Hugh Burkhardt, Rita Crust, Andy Noyes, and Daniel Pead**

We are grateful to the many teachers and students, in the UK and the US,  
who took part in the classroom trials that played a critical role in developing these materials

The classroom observation teams in the US were led by  
**David Foster, Mary Bouck, and Diane Schaefer**

This project was conceived and directed for  
The Mathematics Assessment Resource Service (MARS) by  
**Alan Schoenfeld** at the University of California, Berkeley, and  
**Hugh Burkhardt, Daniel Pead, and Malcolm Swan** at the University of Nottingham

Thanks also to Mat Crosier, Anne Floyde, Michael Galan, Judith Mills, Nick Orchard, and Alvaro Villanueva who contributed to the design and production of these materials

This development would not have been possible without the support of  
**Bill & Melinda Gates Foundation**

We are particularly grateful to  
**Carina Wong, Melissa Chabran, and Jamie McKee**

The full collection of Mathematics Assessment Project materials is available from

<http://map.mathshell.org>

© 2015 MARS, Shell Center, University of Nottingham  
This material may be reproduced and distributed, without modification, for non-commercial purposes,  
under the Creative Commons License detailed at <http://creativecommons.org/licenses/by-nc-nd/3.0/>  
All other rights reserved.

Please contact [map.info@mathshell.org](mailto:map.info@mathshell.org) if this license does not meet your needs.

# SREB

## SREB Readiness Courses

# Ready for High School: Math

### Math Unit 1

### The Number System

Not for Review Copy Distribution

Southern  
Regional  
Education  
Board

592 Tenth Street, NW  
Atlanta, GA 30318  
(404) 875-9211

[www.sreb.org](http://www.sreb.org)



# Unit 1 . The Number System

## Overview

This unit is designed to solidify the understanding of the relationships between fractions, decimals and percents as well as explore scientific notation and irrational numbers.

### Essential Questions:

---

- *What are the relationships between decimals, fractions and percents?*
- *Why is notation of numbers useful in certain contexts?*
- *Why is the form of a number important when solving math problems?*

## College- and Career-Readiness Standards:

---

- NS.2 Apply and extend previous understandings of addition and subtraction to add and subtract rational numbers; represent addition and subtraction on a horizontal or vertical number line diagram.
- NS.3 Apply and extend previous understandings of multiplication and division and of fractions to multiply and divide rational numbers.
- EE.7 Solve multi-step real-life and mathematical problems posed with positive and negative rational numbers in any form (whole numbers, fractions, and decimals), using tools strategically. Apply properties of operations to calculate with numbers in any form; convert between forms as appropriate; and assess the reasonableness of answers using mental computation and estimation strategies.
- NS.4 Know that numbers that are not rational are called irrational. Understand informally that every number has a decimal expansion; for rational numbers show that the decimal expansion repeats eventually, and convert a decimal expansion which repeats eventually into a rational number.
- NS.5 Use rational approximations of irrational numbers to compare the size of irrational numbers, locate them approximately on a number line diagram, and estimate the value of expressions (e.g.,  $\pi^2$ ). For example, by truncating the decimal expansion of  $\sqrt{2}$ , show that  $\sqrt{2}$  is between 1 and 2, then between 1.4 and 1.5, and explain how to continue on to get better approximations.
- EE.10 Use numbers expressed in the form of a single digit times an integer power of 10 to estimate very large or very small quantities, and to express how many times as much one is than the other. For example, estimate the population of the United States as  $3 \times 10^8$  and the population of the world as  $7 \times 10^9$ , and determine that the world population is more than 20 times larger.
- EE.11 Perform operations with numbers expressed in scientific notation, including problems where both decimal and scientific notation are used. Use scientific notation and choose units of appropriate size for measurements of very large or very small quantities (e.g., use millimeters per year for seafloor spreading). Interpret scientific notation that has been generated by technology.

## Prior Scaffolding Knowledge / Skills:

---

- Students should have prior knowledge of methods used to convert numbers to equivalent decimals, fractions and percents.

## Lesson Progression Overview:

Lesson Big Idea	Lesson Details	Content Standards	Process Readiness Indicators
<b>Lesson 1: Entry Event: Examining the Number System</b>	Students will engage in an entry event that requires them to make sense of problems involving various forms such as fractions, decimals, percents, scientific notation and irrational numbers. Students will reason abstractly and quantitatively by and use multiple representations. Some may not know how to order some of the numbers, but they will return to the entry event at the end of the unit.	NS.2 NS.3 NS.4 NS.5 EE.10	PRI 1 PRI 2 PRI 3 PRI 10
<b>Lesson 2: Fractions, Decimals and Percents</b>	Students will convert fractions, decimals and percents to equivalent forms as they describe and justify mathematical understandings by constructing viable arguments, critiquing the reasoning of others and engaging in meaningful discourse. Students will look for and make use of patterns and structure and express regularity in repeated reasoning.	EE.7	PRI 2 PRI 3 PRI 7 PRI 8 PRI 9 PRI 10
<b>Lesson 3: Fractions, Decimals and Percents in Context</b>	Students will solve real-world problems using decimals, fractions and percents and persevere in solving them through reasoning and exploration as they use multiple forms of representations to make sense of the mathematics.	EE.7	PRI 1 PRI 2 PRI 3 PRI 4 PRI 9
<b>Lesson 4: Formative Assessment Lesson: Translating Between Fractions, Decimals and Percents</b>	Students will engage in the Formative Assessment Lesson: Translating Between Fractions, Decimals and Percents. This lesson is intended to help students to compare, convert between and order fractions, decimals, and percents. Students will also use area and linear models of fractions, decimals, and percents to understand equivalence as they attend to precision and look for and make use of patterns and structure.  <a href="http://map.mathshell.org/download.php?fileid=1594">http://map.mathshell.org/download.php?fileid=1594</a>	EE.7	PRI 1 PRI 2 PRI 3 PRI 4 PRI 5 PRI 6 PRI 7 PRI 8 PRI 9 PRI 10
<b>Lesson 5: Addressing Misconceptions about Fractions, Decimals and Percents</b>	Students will be grouped based on misconceptions noted on the post-lesson assessment from the Formative Assessment Lesson: Translating Between Fractions, Decimals and Percents so that they can reflect on mistakes and misconceptions to improve their mathematical understandings. During the lesson they will describe and justify mathematical understanding by constructing viable arguments and critiquing the reasoning of others as they engage in mathematical discourse.	EE.7	PRI 1 PRI 2 PRI 3 PRI 6
<b>Lesson 6: Patterns in Scientific Notation</b>	Students will examine patterns of numbers in scientific notation to develop their own methods as they reason abstractly and quantitatively while using multiple forms of representations. They will look for and express regularity in repeated reasoning and make use of patterns and structure. When appropriate, they will reflect on mistakes and misconceptions as they learn and improve their understanding.	EE.10 EE.11	PRI 1 PRI 2 PRI 3 PRI 5 PRI 6 PRI 7 PRI 8 PRI 9 PRI 10

Lesson Big Idea	Lesson Details	Content Standards	Process Readiness Indicators
<b>Lesson 7: Scientific Notation in Context</b>	Students will make sense of problems as they add, subtract, multiply and divide numbers in scientific notation and apply these operations to real-world problems. They will describe and justify mathematical understandings by constructing viable arguments and engage with others in meaningful discourse.	EE.10 EE.11	PRI 1 PRI 2 PRI 3 PRI 6 PRI 7
<b>Lesson 8: Formative Assessment Lesson: Estimating Length Using Scientific Notation</b>	Students will engage in the Formative Assessment Lesson: Estimating Length Using Scientific Notation. This lesson is intended to help the teacher assess how well students attend to precision and contextualize mathematical ideas as they estimate lengths of everyday objects; convert between decimal and scientific notation; and make comparisons of the size of numbers expressed in both decimal and scientific notation. As students use appropriate tools strategically to support thinking and problem solving, they will also demonstrate flexible use of strategies and methods while reflecting on which procedures seem to work best for specific types of problems. <a href="http://map.mathshell.org/download.php?fileid=1664">http://map.mathshell.org/download.php?fileid=1664</a>	EE.10 EE.11	PRI 1 PRI 2 PRI 3 PRI 4 PRI 5 PRI 6 PRI 7 PRI 8 PRI 9 PRI 10
<b>Lesson 9: Addressing Misconceptions about Scientific Notation</b>	Students will be grouped based on misconceptions noted on the post-lesson assessment for the Formative Assessment Lesson: Estimating Length Using Scientific Notation so that they can reflect on mistakes and misconceptions to improve their mathematical understandings and make sense of problems while persevering in solving. They will also reason abstractly and quantitatively.	EE.10 EE.11	PRI 1 PRI 2 PRI 3 PRI 7 PRI 10
<b>Lesson 10: Rational and Irrational Numbers</b>	Students will demonstrate flexible use of strategies and methods while reflecting on which procedures seem to work best as they compare and contrast the properties of rational and irrational numbers. Throughout the lesson, they will reflect on mistakes and misconceptions and look for and make use of patterns, structure and repeated reasoning.	NS.4 NS.5	PRI 2 PRI 3 PRI 5 PRI 7 PRI 8 PRI 10
<b>Lesson 11: Return to the Entry Event: Examining the Number System</b>	Students will return to the entry event and make sense of problems involving various forms such as fractions, decimals, percents, scientific notation and irrational numbers while reasoning. Students will reason abstractly and quantitatively by using multiple representations as they compare and order numbers in various forms such as fractions, decimals, percents, scientific notation and irrational numbers. Students will reflect on mistakes and misconceptions to improve their mathematical understanding from first lesson as they match equivalent forms of numbers.	NS.2 NS.3 NS.4 EE.10	PRI 1 PRI 2 PRI 3 PRI 10



## The Number System

# Lesson 1 of 11

## Entry Event: Examining the Number System

### Description:

---

Students will make sense of problems involving various forms such as fractions, decimals, percents, scientific notation and irrational numbers. Students will reason abstractly and quantitatively and use multiple representations. Some may not know how to order some of the numbers, but they will return to the entry event at the end of the unit.

### College- and Career-Readiness Standards Addressed:

---

- NS.2 Apply and extend previous understandings of addition and subtraction to add and subtract rational numbers; represent addition and subtraction on a horizontal or vertical number line diagram.
- NS.3 Apply and extend previous understandings of multiplication and division and of fractions to multiply and divide rational numbers.
- NS.4 Know that numbers that are not rational are called irrational. Understand informally that every number has a decimal expansion; for rational numbers show that the decimal expansion repeats eventually, and convert a decimal expansion which repeats eventually into a rational number.
- NS.5 Use rational approximations of irrational numbers to compare the size of irrational numbers, locate them approximately on a number line diagram, and estimate the value of expressions (e.g.,  $\pi^2$ ). For example, by truncating the decimal expansion of  $\sqrt{2}$ , show that  $\sqrt{2}$  is between 1 and 2, then between 1.4 and 1.5, and explain how to continue on to get better approximations.
- EE.10 Use numbers expressed in the form of a single digit times an integer power of 10 to estimate very large or very small quantities, and to express how many times as much one is than the other. *For example, estimate the population of the United States as  $3 \times 10^8$  and the population of the world as  $7 \times 10^9$ , and determine that the world population is more than 20 times larger.*

### Process Readiness Indicator(s) Emphasized:

---

- PRI 1: Make sense of problems and persevere in solving through reasoning and exploration.
- PRI 2: Reason abstractly and quantitatively by using multiple forms of representations to make sense of and understand mathematics.
- PRI 3: Describe and justify mathematical understandings by constructing viable arguments, critiquing the reasoning of others and engaging in meaningful mathematical discourse.
- PRI 10: Reflect on mistakes and misconceptions to improve mathematical understanding.

Sequence of  
Instruction

Activities Checklist

Engage

PRI 1  
PRI 2  
PRI 3

Provide students with three to five cards upon entry to classroom setting. The cards will be in various forms – decimals, fractions, percents, scientific notation, radicals, and irrational numbers. With a partner or alone, students should order the cards from least to greatest at their desks.

*Teacher's Note: Each student will receive a unique set of numbers. The students will not use all the cards in the set at this point. This activity will be completed in the last lesson of the unit. This is only an introduction to the unit.*

Circulate the classroom, and ask questions that will encourage students to justify the placement of the cards. Allow students to work for 5-7 minutes.

Explore

PRI 1  
PRI 2  
PRI 3

*Teacher Notes: Students often have difficulty distinguishing between various representations of rational and irrational numbers. Students also do not commonly understand that scientific notation is a way to represent a very small or very large number. Knowing equivalency for irrational and uncommon rational numbers can also present a challenge.*

Prior to enacting this lesson with students, create a number line in integer format from -30 to 30 using several pieces of chart paper or butcher paper. The number line needs to be large enough for students to place their numbers on it.

Divide the class into groups of 2-4 students. Ask each group to work together to order their cards on the class number line.

Allow students 10-20 minutes depending on whether calculators are provided (teacher choice).

As students are working, formatively assess their understanding. Listen to what students say as they explain their reasoning to their partner. Encourage students to discuss the difference between terminating and repeating decimals, and rational and irrational numbers.

If the majority of the class is struggling with the placement of cards, allow 4-6 students to share one card they are struggling to place. Ask questions such as the following:

- Has anyone placed Susan's card? How did you decide where it should go on the number line?
- Jason placed this card between \_\_\_ and \_\_\_. Why do you think he decided this was the right place for this card?
- Does someone have an irrational number he can place between 0 and 10? How do you know this is the right place for this card?
- Does someone else have a number represented in scientific notation between 0 and 1? How do you know this is the right place for this card?

## Explanation

### PRI 3

Based on class data, ask students to provide written justifications on written response form for the smallest, largest and median numbers; the second smallest, second largest, the third smallest, third largest and fourth smallest, fourth largest.

*Teacher's Note: The written portion can be differentiated by asking students to identify two numbers closest to zero, the number farthest from zero, etc.*

INCLUDED IN THE STUDENT MANUAL

#### Task #1: Written Response Form

Write the numbers on your cards in the space below:

Order the numbers from least to greatest:

How did you determine which number was the largest?

How did you determine which number was the smallest?

How did you determine the order of the other numbers?

## Practice Together / in Small Groups / Individually

### PRI 3

Using colored stickers for each set of identified numbers, ask students to label each identified number by placing the appropriate color sticker on the card. For example, red labels represent the largest, smallest and median numbers. Yellow stickers identify the second smallest, second largest, etc.

*Teacher's Note: If stickers are not available, students can label the identified numbers using specific color markers.*

## Evaluate Understanding

### PRI 3

### PRI 10

Groups either agree or disagree with other group's findings and report out what changes, if any should be made.

Collect the written response form and assess whether students understand the placement of certain numbers on the number line.

## Closing Activity

### PRI 1

### PRI 2

Ask students to choose a number from their poster and write it on their mini-whiteboard. Start an "I have, who has" chain. For example: Say "I have the square root of 2. Who has a number smaller than me?" The first student who answers correctly says "I have \_\_\_\_\_. Who has a number at least one greater than me?" The chain continues.

## Independent Practice:

---

INCLUDED IN THE STUDENT MANUAL

### Lesson 1 Exit Slip

Using what you have learned today, put the following numbers in order from least to greatest:

$$-\frac{1}{2}, \frac{2}{3}, 0.66, 1.3, \sqrt{3}, -0.25, -0.5$$

## Resources/Instructional Materials Needed:

---

- Cards – 100 different numbers including decimals, fractions, %, scientific notation, radicals, irrationals
- Number line (-30 to 30)
- Task #1: Written Response Form
- Colored stickers or markers
- Chart paper
- Mini-whiteboard
- Dry erase markers
- Erasers for the mini-whiteboards

## Notes:

---

- This lesson can be amended when using only two cards per student.
- This lesson is repeated at the end of the unit. All 100 cards should be used at that time.

**-28.75**

**-27.65**

**-26.89**

**-22.45**

**-20.1**

**-19.01**

**-18.67**

**-16.5**

**-14.99**

Review Copy  
Not for Distribution

**-12.3**

**-12.2**

**-7.5**

**-5.4**

**-4.25**

**-1.95**

**-0.66**

**-0.01**

**$0.\overline{3}$**

Review Copy  
Not for Distribution

**0.75**

**2.05**

**4.75**

**5. $\bar{6}$**

**6.75**

**9.75**

**10.05**

**12. $\bar{3}$**

**12.8**

Review Copy  
Not for Distribution

<b>16.25</b>	<b>18.3</b>	<b>19.5</b>
<b>-500%</b>	<b>-425%</b>	<b>-200%</b>
<b>-66%</b>	<b>-10%</b>	<b>0%</b>

Not for Review Copy  
Distribution



<b>30%</b>	<b>50%</b>	<b>80%</b>
<b>210%</b>	<b>350%</b>	<b><math>-3 \times 10^1</math></b>
<b><math>-0.0276 \times 10^3</math></b>	<b><math>-2600 \times 10^{-2}</math></b>	<b><math>-22500 \times 10^{-3}</math></b>

Not for Review Copy  
Distribution

$$-0.00221 \times 10^4$$

$$-0.02 \times 10^3$$

$$-1.9 \times 10^1$$

$$-185 \times 10^{-1}$$

$$-16400 \times 10^{-3}$$

$$-0.0015 \times 10^4$$

$$-0.0124 \times 10^3$$

$$-1125 \times 10^{-2}$$

$$-7350 \times 10^{-3}$$

Not for Review Copy  
Distribution

$$-725 \times 10^{-2}$$

$$-0.0005 \times 10^4$$

$$-0.041 \times 10^2$$

$$-100000 \times -10^5$$

$$-0.05 \times 10^1$$

$$-0.01 \times 10^1$$

$$3000 \times 10^{-4}$$

$$10 \times 10^{-1}$$

$$21 \times 10^{-1}$$

Not for Review Copy  
Distribution

$$5100 \times 10^{-3}$$

$$0.0006 \times 10^4$$

$$0.0065 \times 10^3$$

$$910000 \times 10^{-5}$$

$$0.1 \times 10^2$$

$$0.0013 \times 10^4$$

$$150000 \times 10^{-4}$$

$$0.163 \times 10^2$$

$$1730 \times 10^{-2}$$

Not for Review Copy  
Distribution

$19500 \times 10^{-3}$	$0.002345 \times 10^4$	$0.205 \times 10^2$
$27500 \times 10^{-3}$	<b>20.42</b>	<b>22.6</b>
<b>24.75</b>	<b>27.5</b>	<b>28.4</b>

Not for Review Copy  
Distribution

**29.9**

**$-4\frac{2}{5}$**

**$-\frac{3}{5}$**

**$-\frac{1}{10}$**

**$\frac{1}{3}$**

**$\frac{3}{4}$**

**$\frac{10}{5}$**

**$\frac{35}{7}$**

**$9\frac{4}{5}$**

Review Copy  
Not for Distribution

$$-\pi$$

$$\sqrt{0.1}$$

$$\sqrt{2}$$

$$\pi$$

$$\sqrt{13}$$

$$2\sqrt{7}$$

$$\sqrt{52}$$

$$\sqrt{88}$$

$$\sqrt{99}$$

Review Copy  
Not for Distribution

$$7\sqrt{3}$$

$$8\sqrt{3}$$

$$7\sqrt{5}$$

$$\sqrt{333}$$

$$11\sqrt{13}$$

$$5\sqrt{17}$$

$$\sqrt{510}$$

$$8\sqrt{10}$$

$$\sqrt{790}$$

Not for Review Copy  
Distribution



$$9\sqrt{10}$$

$$5\sqrt{34}$$

$$-1\sqrt{889}$$

$$-\sqrt{757}$$

$$-15\sqrt{3}$$

$$-\sqrt{491}$$

$$\sqrt{510}$$

$$8\sqrt{10}$$

$$\sqrt{790}$$

Review Copy  
Not for Distribution

$$-\sqrt{465}$$

$$-6\sqrt{13}$$

$$-\sqrt{380}$$

$$-7\sqrt{7}$$

$$-10\sqrt{3}$$

$$-10\sqrt{2}$$

$$-\sqrt{145}$$

$$-\sqrt{103}$$

$$-5\sqrt{3}$$

Not for Review Copy  
Distribution

$$-6\sqrt{2}$$

$$-3\sqrt{3}$$

$$-\sqrt{0.001}$$

$$-\sqrt{2}$$

$$-22.\bar{4}$$

$$-7.\bar{5}$$

$$20.42$$

$$22.6$$

$$24.75$$

Review Copy  
Not for Distribution

**27.5**

**28.4**

**29. $\bar{9}$**

**$-\frac{60}{2}$**

**$-27\frac{5}{8}$**

**$-25\frac{3}{4}$**

**$-\frac{48}{2}$**

**$-22\frac{1}{2}$**

**$-\frac{60}{3}$**

Review Copy  
Not for Distribution

$$-19 \frac{1}{10}$$

$$-18 \frac{3}{5}$$

$$-15 \frac{2}{7}$$

$$-14 \frac{4}{5}$$

$$-\frac{36}{3}$$

$$-12 \frac{1}{5}$$

$$-7 \frac{1}{2}$$

$$-7 \frac{1}{3}$$

$$-5 \frac{1}{2}$$

Review Copy  
Not for Distribution

$$-\frac{24}{12}$$

$$\frac{4}{5}$$

$$5\frac{2}{3}$$

$$\frac{35}{5}$$

$$10\frac{1}{5}$$

$$13\frac{4}{5}$$

$$14\frac{2}{3}$$

$$16\frac{1}{4}$$

$$18\frac{1}{4}$$

Review Copy  
Not for Distribution

$$19\frac{1}{2}$$

$$\frac{42}{2}$$

$$22\frac{1}{2}$$

$$\frac{75}{3}$$

$$28\frac{3}{10}$$

$$28\frac{1}{2}$$

$$29\frac{9}{10}$$

Not for Review Copy  
Distribution

**Card Sort Answer Key - Lesson 9 Cards in order from least to greatest**

$-\frac{60}{2}$	-18.67	$-0.0005 \times 10^4$	0.75	$9\frac{4}{5}$	$22\frac{1}{2}$
$-3 \times 10^1$	$-18\frac{3}{5}$	-500%	$\frac{3}{4}$	$\sqrt{99}$	$\sqrt{510}$
$-1\sqrt{889}$	$-7\sqrt{7}$	-4.99	80%	$0.1 \times 10^2$	22.6
-28.75	$-185 \times 10^{-1}$	$-4\frac{2}{5}$	$\frac{4}{5}$	10.05	24.75
-28.4	$-10\sqrt{3}$	-4.25	$10 \times 10^{-1}$	$10\frac{1}{5}$	$\frac{75}{3}$
-27.65	$-16,400 \times 10^{-3}$	-425%	$\sqrt{2}$	$7\sqrt{3}$	$8\sqrt{10}$
$-27\frac{5}{8}$	$-15\frac{2}{7}$	$-0.041 \times 10^2$	$15000 \times 10^{-4}$	$12.\bar{3}$	27.5
$-0.0276 \times 10^3$	$-0.0015 \times 10^4$	$-\pi$	$\frac{10}{5}$	12.8	$27500 \times 10^{-3}$
$-\sqrt{757}$	$-14\frac{4}{5}$	-2.05	210%	$0.0013 \times 10^4$	$\sqrt{790}$
-26.89	$-10\sqrt{2}$	$-\frac{24}{12}$	$21 \times 10^{-1}$	$13\frac{4}{5}$	$28\frac{3}{10}$
$-2600 \times 10^{-2}$	$-0.0124 \times 10^3$	-200%	$0.002345 \times 10^5$	$8\sqrt{3}$	28.4
$-15\sqrt{3}$	-12.3	-1.95	$\pi$	$14\frac{2}{3}$	$9\sqrt{10}$
$-25\frac{3}{4}$	-12.2	$\sqrt{2}$	350%	$7\sqrt{5}$	$28\frac{1}{2}$
$-\frac{48}{2}$	$-12\frac{1}{5}$	$-100000 \times 10^{-5}$	$\sqrt{13}$	$16\frac{1}{4}$	$5\sqrt{34}$
$-22\frac{1}{2}$	$-\sqrt{145}$	-0.66	$1\sqrt{13}$	16.25	$29\frac{9}{10}$
$-22,500 \times 10^{-3}$	$-\frac{36}{3}$	-66%	4.75	$0.163 \times 10^2$	29. $\bar{9}$
-22.45	$-1125 \times 10^{-2}$	$-\frac{3}{5}$	$\frac{35}{7}$	16.5	
-22.4	$-\sqrt{103}$	$-0.05 \times 10^1$	$5100 \times 10^{-3}$	$1730 \times 10^{-2}$	
$-\sqrt{491}$	$5\sqrt{3}$	$-\frac{1}{10}$	$2\sqrt{7}$	$\sqrt{333}$	
$-0.00221 \times 10^4$	$6\sqrt{2}$	-10%	$5.\bar{6}$	$18\frac{1}{4}$	
$-6\sqrt{13}$	-7.5	$-0.01 \times 10^1$	$5\frac{2}{3}$	18.3	
$-\sqrt{465}$	$-7\frac{1}{2}$	$-\sqrt{0.001}$	$0.006 \times 10^4$	19.5	
-20.1	-7.5	-0.01	$0.0065 \times 10^3$	$19\frac{1}{2}$	
$-\frac{60}{3}$	$-7350 \times 10^{-3}$	0%	6.75	$19500 \times 10^{-3}$	
$-0.02 \times 10^3$	$-7\frac{1}{3}$	30%	$\frac{35}{5}$	20.42	
$-\sqrt{380}$	$-725 \times 10^{-2}$	$3000 \times 10^{-4}$	$\sqrt{52}$	$0.205 \times 10^2$	
$-19\frac{1}{10}$	$-5\frac{1}{2}$	$-\sqrt{0.1}$	$910000 \times 10^{-5}$	$5\sqrt{17}$	
-19.01	-5.4	.03	$\sqrt{88}$	$\frac{42}{2}$	
$-1.9 \times 10^1$	$-3\sqrt{3}$	$\frac{1}{3}$	9.75		
		50%			



## The Number System

# Lesson 2 of 11

## Fractions, Decimals and Percents

### Description:

---

Students will convert fractions, decimals and percents to equivalent forms as they describe and justify mathematical understandings by constructing viable arguments, critiquing the reasoning of others and engaging in meaningful discourse. Students will look for and make use of patterns and structure and express regularity in repeated reasoning.

### College- and Career-Readiness Standards Addressed:

---

- EE.7 Solve multi-step real-life and mathematical problems posed with positive and negative rational numbers in any form (whole numbers, fractions, and decimals), using tools strategically. Apply properties of operations to calculate with numbers in any form; convert between forms as appropriate; and assess the reasonableness of answers using mental computation and estimation strategies.

### Process Readiness Indicator(s) Emphasized:

---

- PRI 2: Reason abstractly and quantitatively by using multiple forms of representations to make sense of and understand mathematics.
- PRI 3: Describe and justify mathematical understandings by constructing viable arguments, critiquing the reasoning of others and engaging in meaningful mathematical discourse.
- PRI 7: Look for and make use of patterns and structure.
- PRI 8: Look for and express regularity in repeated reasoning.
- PRI 9: Demonstrate flexible use of strategies and methods while reflecting on which procedures
- PRI 10: Reflect on mistakes and misconceptions to improve mathematical understanding.

Sequence of  
Instruction

Activities Checklist

Engage

PRI 2  
PRI 3  
PRI 7  
PRI 8

Assign students to work in pairs based on similar abilities. Explain they will use the interactive Fraction Models found at <http://illuminations.nctm.org/Activity.aspx?id=3519> to answer the following questions:

1. What happens when you change only the numerator?
2. What happens when you change only the denominator?
3. What does it mean when the numerator is larger than the denominator?
4. What conjecture can you make about the relationship between fractions, decimals and percents?

Facilitate a short whole-class discussion. Ask students to explain their answers to the four questions. Then ask: "How can you prove without using technology 0.75, 75% and  $\frac{3}{4}$  are equivalent?" Allow students a few minutes to discuss the answer with their partner. Ask one or two groups to share their reasoning.

*Alternate Activity for Classes without Computer/Internet Access:*

*Teachers Commentary:*

*For those classrooms where accessing the online activity will not be possible, facilitate a classroom discussion about the same concept. Students should use calculators so that they can answer these questions:*

1. What happens when you change only the numerator?
2. What happens when you change only the denominator?
3. What does it mean when the numerator is larger than the denominator?
4. What conjecture can you make about the relationship between fractions, decimals and percents?

*Use the following examples (create a chart on the board to record the various forms):*

*Start with  $\frac{1}{2}$ .*

*Help students convert this fraction to a decimal and a percent.*

*Now use  $\frac{1}{3}$  and  $\frac{1}{4}$ . Discuss what happens to the decimal and percent as the denominator changes.*

*Go back to  $\frac{1}{2}$ . Now use  $\frac{2}{2}$ ,  $\frac{3}{2}$ ,  $\frac{4}{2}$  and convert them to a decimal and percent.*

*Students should now answer questions 1 through 4.*

## Explore

**PRI 3**  
**PRI 10**

Students work with their partner to complete the following without the use of technology:

INCLUDED IN THE STUDENT MANUAL

### Task #2: Multiple Representations

1. Find the fraction and percent form of each decimal number:

0.5  
0.75  
0.2  
0.8  
1.25

2. Find the decimal and percent form of each fraction:

$\frac{1}{3}$

$\frac{1}{2}$

$\frac{2}{3}$

$\frac{5}{8}$

3. Find the decimal and fraction form of each percent:

50%  
35%  
110%  
15%

4. Answer the following questions on notebook paper:

- Which numbers are the most difficult to convert to decimals? Why?
- Which numbers are the most difficult to convert to fractions? Why?
- Which numbers are the most difficult to convert to percents? Why?

After 20-30 minutes, ask students to compare their answers to at least two other groups of students.

- What did you agree on?
- What did you disagree about?

*Teacher's Notes: You may want to remind students about how to convert between the different forms of numbers. As students work, circulate around the room to help students with their calculations.*

*Once the groups have finished their calculations, they should develop written responses to the questions. Encourage the groups to write detailed explanations about their thinking. Once each group has had a chance to think and write about their ideas, they should compare their calculations and their answers to the questions with another group.*

As students are critiquing each other's reasoning, circulate around the room and select at least three groups to share their thinking. Talk to each group ahead of time to be sure they know that they will be called upon to explain their answers. Facilitate a whole-class discussion about why some calculations are easier than others. The discussion should help clear up misconceptions about how to calculate equivalent forms of numbers.

## Explanation

**PRI 3**  
**PRI 9**

Ask students to put the numbers from the “Explore” part of the lesson on a number line from 0 to 2.

Ask students:

- Why are some numbers in the same location on the number line?
- What conjecture can you make about numbers that are on the same spot on the number line?

Allow students 3-5 minutes to discuss the questions with their partner. Facilitate a whole-class discussion that focuses on equivalent forms of a number. Here are some questions you may want to use during the discussion:

- How do you know that two numbers are equivalent by looking at the number line?
- Can we make things easier by only using one form of the number? Why or why not?
- Why is it important to be able to use all the forms of a number?
- How can you determine the best form to use for a situation? *Teacher's Note: This lesson did not focus on this question. This question allows the teacher to pre-assess students' thinking about this topic, which will be discussed in Lesson 3.*

## Practice Together / in Small Groups / Individually

Students will practice identifying equivalent forms of fractions, decimals and percents using the applet. The game is similar to “Memory.”

<http://illuminations.nctm.org/Activity.aspx?id=3563>

*Teacher's Note: When students go to the Illuminations site, be sure they choose the option located in the second column, third row of the graphic.*

*Students can work alone or with a partner. Allow students 10 minutes.*



## Evaluate Understanding

### PRI 3

INCLUDED IN THE STUDENT MANUAL

#### Task #3: Different Representations

Complete the table, filling in the missing numbers.

Fraction	Decimal	Percent
$\frac{1}{2}$		
	0.05	
		85%

Place all nine numbers from the table onto the number line.



How can you determine if your answers are correct?

Instruct students to complete the table, and place all nine numbers from the table on a number line.

How can you determine if your answers are correct?

*Teacher's Note: Formatively assess students' responses. The best answer will mention only three locations on the number line should be marked since each row in the table shows equivalent numbers.*

## Closing Activity

### PRI 10

#### Exit Ticket

1. What was the most interesting thing you learned today?
2. What do you still need help understanding?

## Independent Practice:

Students may benefit from having more practice. Practice sheets are available at:

[http://www.math-drills.com/fractions/convert\\_fractions\\_decimals\\_percents\\_ratios\\_005.html](http://www.math-drills.com/fractions/convert_fractions_decimals_percents_ratios_005.html)

## Resources/Instructional Materials Needed:

- Internet access
- Student laptops, computers, or tablets
- Task #2: Multiple Representations
- Task #3: Different Representations

## The Number System

# Lesson 3 of 11

## Fractions, Decimals and Percents in Context

### Description:

---

Students will solve real-world problems using decimals, fractions and percents and persevere in solving them through reasoning and exploration as they use multiple forms of representations to make sense of the mathematics.

### College- and Career-Readiness Standards Addressed:

---

- EE.7 Solve multi-step real-life and mathematical problems posed with positive and negative rational numbers in any form (whole numbers, fractions, and decimals), using tools strategically. Apply properties of operations to calculate with numbers in any form; convert between forms as appropriate; and assess the reasonableness of answers using mental computation and estimation strategies.

### Process Readiness Indicator(s) Emphasized:

---

- PRI 1: Make sense of problems and persevere in solving through reasoning and exploration
- PRI 2: Reason abstractly and quantitatively by using multiple forms of representations to make sense of and understand mathematics.
- PRI 3: Describe and justify mathematical understandings by constructing viable arguments, critiquing the reasoning of others and engaging in meaningful mathematical discourse.
- PRI 4: Contextualize mathematical ideas by connecting them to real-world situations. Model with mathematics.
- PRI 9: Demonstrate flexible use of strategies and methods while reflecting on which procedures

## Engage

### PRI 4

Distribute copies of the Summer Daze activity from <http://illuminations.nctm.org/Lesson.aspx?id=2847> to students. Instruct students to complete the activity individually. Limit students to no more than 5 activities.

INCLUDED IN THE STUDENT MANUAL

#### Task #4: How I Spent My Summer Daze



List your activities on a typical summer day in the first column. In the second column, estimate the number of whole hours you spend on this activity in a day. Then, complete each row of the table by converting the number of hours per day to a fraction in lowest terms, a decimal, a percent, and the number of degrees this represents in a circle. Use the values you calculated to create a pie chart that represents your Summer Daze.

DAILY ACTIVITY	HOURS	FRACTION	DECIMAL	PERCENT	DEGREES
TOTAL					

## Explore

---

**PRI 2**  
**PRI 3**  
**PRI 9**

Instruct students to work with a partner to discuss the following questions based on their individual responses to the Summer Daze activity:

1. How did you decide what form the answer should be in (decimal, fraction or percent)?
2. Why does it matter which form the answer is in?
3. Which types of problems were the hardest to solve? Why?

Ask students to discuss and compare their responses to the three questions to at least two other groups of students.

- What did you agree on?
- What did you disagree about?

*Teacher's Notes: You may want to remind your students about how to convert between the different forms of numbers. As students work, circulate around the room to help students with their calculations.*

*Once the groups have finished their calculations, they should develop written responses to the questions. Encourage the groups to write detailed explanations about their thinking. Once each group has had a chance to think and write about their ideas, they should compare their answers with other groups. Students should be comparing their answers on the calculations as well as their answers to the questions.*

*As students are critiquing the reasoning of each other, circulate around the room and find at least three groups to share their thinking. Talk to each group ahead of time to be sure they know that they will be called upon to explain their answers. Lead the class in a discussion about why some calculations are easier than others. The discussion should help clear up misconceptions about how to calculate equivalent forms of numbers.*

## Explanation

---

**PRI 2**  
**PRI 3**

Instruct students after they have talked to at least two other groups about their methods of solving the problems, they should create an instructional guide to solving real-world problems using fractions, decimals and percents. Students should consider the following while creating their instructions:

- Why do we need to be able to use different forms of a number?
- How can we determine the best form to use for a situation?

## Practice Together / in Small Groups / Individually

---

**PRI 1**  
**PRI 2**  
**PRI 4**

Students will be grouped in pairs based on similar abilities. Each group will create a real-world problem for each of the following scenarios:

- a. The answer is a fraction.
- b. The answer is a decimal.
- c. The answer is a percentage.

Students will give their problems to other groups for practice. All problems should have a detailed answer key on a separate piece of paper.



## Evaluate Understanding

---

The teacher will evaluate student understanding by checking the group work.

## Closing Activity

---

**PRI 3**

Exit Ticket:

What is the best way to figure out if an answer should be in the form of a decimal, fraction or percent?

## Independent Practice:

---

<http://downloads.bbc.co.uk/skillswise/maths/ma18comp/worksheet/ma18comp-l1-w-problem-solving-with-fractions-decimals-and-pct.pdf>

or

<https://www.illustrativemathematics.org/content-standards/7/NS/A/3/tasks/298>

## Resources/Instructional Materials Needed:

---

- Internet access
- Student laptops, computers or tablets
- Task #4: How I Spent My Summer Daze

## Notes:

---

---

---

---

---

---

---

---

---

---

---

---

---

---

---

---

---

---

---

---

---

---

---

---

## The Number System

# Lesson 4 of 11

## Formative Assessment Lesson: Translating Between Fractions, Decimals and Percents

### Description:

---

Students will engage in the Shell Center Formative Assessment Lesson: Translating Between Fractions, Decimals and Percents. This lesson is intended to help students to compare, convert between and order fractions, decimals, and percents. Students will also use area and linear models of fractions, decimals, and percents to understand equivalence as they attend to precision and look for and make use of patterns and structure.

### College- and Career-Readiness Standards Addressed:

---

- EE.7 Solve multi-step real-life and mathematical problems posed with positive and negative rational numbers in any form (whole numbers, fractions, and decimals), using tools strategically. Apply properties of operations to calculate with numbers in any form; convert between forms as appropriate; and assess the reasonableness of answers using mental computation and estimation strategies.

### Process Readiness Indicator(s) Emphasized

---

- PRI 1: Make sense of problems and persevere in solving through reasoning and exploration
- PRI 2: Reason abstractly and quantitatively by using multiple forms of representations to make sense of and understand mathematics.
- PRI 3: Describe and justify mathematical understandings by constructing viable arguments, critiquing the reasoning of others and engaging in meaningful mathematical discourse.
- PRI 4: Contextualize mathematical ideas by connecting them to real-world situations. Model with mathematics.
- PRI 5: Use appropriate tools strategically to support thinking and problem solving.
- PRI 6: Attend to precision.
- PRI 7: Look for and make use of patterns and structure.
- PRI 8: Look for and express regularity in repeated reasoning.
- PRI 9: Demonstrate flexible use of strategies and methods while reflecting on which procedures
- PRI 10: Reflect on mistakes and misconceptions to improve mathematical understanding.

Students will engage in the Formative Assessment Lesson: Translating Between Fractions, Decimals and Percents, which can be found at: <http://map.mathshell.org/download.php?fileid=1594>

The following *Formative Assessment Lesson* is a classroom-ready lesson included to help teachers assess and improve students' understanding of mathematical concepts and skills and their ability to use the mathematical process readiness indicators critical for college readiness.

Research has shown that formative assessment, as embodied in the following lesson, is a powerful way to improve student learning and performance. This approach first allows students to demonstrate their prior understandings and abilities in employing the mathematical processes, and then resolve their own difficulties and misconceptions through structured discussion. This results in more secure long-term learning, reducing the need for re-teaching that otherwise takes so much classroom time.

Many often ask, why don't students just remember the procedures they have been taught and practiced? The fact is, that approach works fine in the short term but, as every teacher knows, if procedural knowledge is not underpinned by conceptual understanding, students will quickly forget "how to do it."

Read more about the *Formative Assessment Lesson* rationale, structure, and philosophy using the *Brief Guide for Teachers and Administrators* that can be found at <http://map.mathshell.org/materials/index.php>.

Review Copy  
Not for Distribution

## CONCEPT DEVELOPMENT

Mathematics Assessment Project  
**CLASSROOM CHALLENGES**  
A Formative Assessment Lesson

# Translating between Fractions, Decimals and Percents

Not for Review Copy  
Distribution

Mathematics Assessment Resource Service  
University of Nottingham & UC Berkeley

For more details, visit: <http://map.mathshell.org>  
© 2015 MARS, Shell Center, University of Nottingham  
May be reproduced, unmodified, for non-commercial purposes under the Creative Commons license  
detailed at <http://creativecommons.org/licenses/by-nc-nd/3.0/> - all other rights reserved

## BEFORE THE LESSON

### Assessment task: *Fractions, Decimals, and Percents* (15 minutes)

Have students complete this task, in class or for homework, a few days before the formative assessment lesson. This will give you an opportunity to assess the work and to find out the kinds of difficulties students have with it. You should then be able to target your help more effectively in the subsequent lesson.

Give each student a copy of the assessment task *Fractions, Decimals, and Percents* and briefly introduce the task:

*You are asked to put numbers in order, or to check which number is greater and then explain why.*

*Make sure that you explain your method clearly. You may draw diagrams to help you explain, if you wish.*

*I want to understand how you are working them out.*

It is important that, as far as possible, students are allowed to answer the questions without assistance. They should not have access to calculators.

Students should not worry too much if they cannot understand or do everything, because in the next lesson they will work on a similar task that should help them. Explain to students that by the end of the next lesson they should be able to answer questions such as these confidently. This is their goal.

### Assessing students' responses

Collect students' responses to the task. Make some notes on what their work reveals about their current levels of understanding and their different problem-solving approaches.

We suggest that you do not score students' work. Research shows that this will be counterproductive, as it will encourage students to compare their scores and distract their attention from what they can do to improve their mathematics.

Instead, help students to make further progress by summarizing their difficulties as a series of questions. Some suggestions for these are given in the *Common issues* table on the page T-4. These have been drawn from common difficulties observed in trials of this unit. We suggest you make a list of your own questions, based on your students' work.

**Fractions, Decimals, and Percents**

1. Put the following decimals in order of size, starting with the one with the least value:

0.125    0.4    0.62    1.05    0.05

.....

Least Greatest

Explain your method for doing this.

.....

.....

.....

2. Put the following fractions in order of size, starting with the one with the least value:

$\frac{3}{4}$      $\frac{9}{16}$      $\frac{3}{16}$      $\frac{7}{8}$      $\frac{3}{8}$

.....

Least Greatest

Explain your method for doing this.

.....

.....

.....

Put a check mark in each case to say which number is larger.

Explain your answer each time on the dotted lines underneath.

(a) 40%  or  $\frac{1}{4}$

Explain how you know.

.....

.....

(b) 0.7  or  $\frac{3}{5}$

Explain how you know.

.....

.....

(c) 33%  or 0.4

Explain how you know.

.....

.....

We recommend you either:

- write one or two questions on each student's work, or
- give each student a printed version of your list of questions and highlight appropriate questions for each student.

If you do not have time to do this, you could select a few questions that will be of help to the majority of students, and write these on the board when you return the work to the student in the follow-up lesson.

Review Copy  
Not for Distribution

Common issues	Suggested questions and prompts
<p><b>Assumes the ‘length’ of a decimal determines its relative size (Q1)</b></p> <p>For example: The student assumes <math>0.4 &lt; 0.125</math> because <math>4 &lt; 125</math> (‘longer’ decimals are greater).</p> <p>Or: Assumes <math>0.4 &gt; 0.62</math> because 0.4 is in tenths and 0.62 is in hundredths and tenths are greater than hundredths (‘longer decimals are smaller’).</p> <p>Or: Assumes that <math>0.4 &gt; 0.62</math> because <math>1/4 &gt; 1/62</math> (‘longer decimals are smaller’).</p>	<ul style="list-style-type: none"> <li>• Can you show me on this number line where you would place 0.4, 0.125 and 0.62?</li> <li>• Which is greater in value: 0.5 or 0.50? Why?</li> <li>• Is it true that you can tell which of two decimals is bigger by counting the digits?</li> </ul>
<p><b>Compares numerators and denominators independently when comparing fractions (Q2)</b></p> <p>For example: The student reasons that <math>3/4 &lt; 9/16</math> because <math>3 &lt; 9</math> and <math>4 &lt; 16</math>.</p>	<ul style="list-style-type: none"> <li>• Which is greater <math>2/3</math> or <math>4/6</math>? Why?</li> <li>• If you double the numerator and denominator does this change the size of the fraction? Why?</li> <li>• Can you tell how big a fraction is by looking at the size of the numerator and denominator separately?</li> </ul>
<p><b>Ignores the numerator or denominator when comparing fractions (Q2)</b></p> <p>For example: The student reasons that <math>9/16 &lt; 3/8</math> because sixteenths are smaller than eighths (ignores numerator).</p>	<ul style="list-style-type: none"> <li>• Which is greater <math>3/8</math> or <math>6/16</math>? Why?</li> <li>• Now which is greater <math>9/16</math> or <math>3/8</math>?</li> </ul>
<p><b>Assumes <math>n\%</math> is the same as <math>1/n</math></b></p> <p>For example: The student appears to believe that 40% and <math>1/4</math> are equivalent (Q3).</p>	<ul style="list-style-type: none"> <li>• Can you draw a diagram to show the meaning of <math>1/4</math>?</li> <li>• Can you draw a diagram to show the meaning of 40%?</li> </ul>
<p><b>Assumes that fractions are always smaller/greater than percents</b></p> <p>For example: The student states <math>1/4</math> is smaller than 40% because <math>1/4</math> is a fraction (Q3).</p>	<ul style="list-style-type: none"> <li>• What do you understand by <math>1/4</math>?</li> <li>• What do you understand by 40%?</li> </ul>
<p><b>Focuses on size of digits rather than entire number (Q3)</b></p> <p>For example: The student states 33% is greater than 0.4 because 33 is greater than 4 (or 0.4).</p> <p>Or: The student states 0.7 is greater than <math>3/5</math> (which it is) because 7 is greater than 3 or 5.</p>	<ul style="list-style-type: none"> <li>• What is the difference between 33 and 33%?</li> <li>• What is the difference between 4 and 0.4?</li> <li>• Can you draw a diagram to show the meaning of 0.7?</li> <li>• Can you draw a diagram to show the meaning of <math>3/5</math>?</li> </ul>
<p><b>Answers all questions correctly with valid explanations</b></p>	<ul style="list-style-type: none"> <li>• For each of these pairs of numbers, can you find a number in between them in size?</li> <li>• Can you write each of your numbers as a fraction, decimal and percentage?</li> </ul>

## SUGGESTED LESSON OUTLINE

### Introduction (5 minutes)

Remind students of the task they completed last lesson:

*Do you remember the work you did on fractions, decimals, and percents?*

*Today you are going to develop your understanding of fractions, decimals, and percents further.*

### Collaborative small-group work (40 minutes)

Ask students to work in groups of two or three. Give each group cut-up copies of *Card Set A: Decimals and Percents* and some plain paper. Ask them to fill in the blanks on the cards.

*Figure out the missing decimals or percents and fill them in on the cards.*

*Leave the card with neither a decimal nor percent for now.*

*When you have done, place the cards in order from the smallest on the left to the largest on the right.*

Explain how students are to work together, using Slide P-1:

**Working Together 1**

Take turns to:

1. Fill in the missing decimals and percents.
2. Place a number card where you think it goes on the table, from smallest on the left to largest on the right.
3. Explain your thinking.
4. The other members of your group must check and challenge your explanation if they disagree.
5. Continue until you have placed all the cards in order.
6. Check that you all agree about the order. Move any cards you need to, until everyone in the group is happy with the order.

Students may use their plain paper for rough calculations and to explain their thinking to each other. They should not use calculators.

The purpose of this task is to see what misconceptions students may have, so do not correct them if they place the cards in the wrong order. If students cannot agree on an order, you do not need to help them to resolve this at this stage, as the subsequent work in the lesson will help with that.

When most groups have reached a consensus about the cards, give out *Card Set B: Areas*.

*Most groups have placed some of the cards correctly and some incorrectly. That's okay for the moment. Please leave the cards on the table.*

*I am going to give you some more cards and I want you to match these to the decimals/percents cards.*

*Cards that have the same value should go at the same position, underneath each other. Look up and down to make sure.*

*Fill in any gaps on the cards so that every card has a match. You will need to complete the blank card from Card Set A now too.*

*Check that the cards are in the right order, from smallest to greatest.*

*If you change your mind, then make a note of what you did wrong the first time.*



Slide P-2 summarizes these instructions:

**Working Together 2**

Take turns to:

1. Match each area card to a decimals/percents card.
2. Create a new card or fill in spaces on cards until all the cards have a match.
3. Explain your thinking to your group. The other members of your group must check and challenge your explanation if they disagree.
4. Place your cards in order, from smallest on the left to largest on the right. Check that you all agree about the order. Move any cards you need to, until you are all happy with the order.

As groups continue to work, give out *Card Set C: Fractions* and *Card Set D: Scales*. The instructions are the same and should not need repeating. However, do make sure that students are completing the blank cards so that each number is represented in each of the four ways (decimal/percent; area; fraction; scale.)

The reason we are suggesting that you give the cards out in this order is that students usually associate decimals with number lines and fractions with areas. The process we describe here should encourage them to make connections that they do not normally make.

While students are working you have two tasks: to note different student approaches to the task and to support student problem solving.

#### Note different student approaches

Listen to and watch students carefully. Notice how students make a start on the task, where they get stuck, and how they overcome any difficulties. Which card sets do they find easiest/hardest to order? Which matches do they find easiest/hardest to make? What calculations do they perform? What sketches do they find helpful/unhelpful? What misconceptions are manifest? What disagreements are common?

In particular, notice whether students are addressing the difficulties they experienced in the assessment task. Note also any common mistakes. You may want to use the questions in the *Common issues* table to help address any misconceptions that arise.

#### Support student problem solving

Help students to work constructively together. Remind them to look at Slide P-2 for instructions on how to work. Check that students listen to each other and encourage them to do any necessary calculations or drawings on their plain paper.

Try not to solve students' problems or do the reasoning for them. Instead, you might ask strategic questions to suggest ways of moving forward:

*If you're stuck with that card, you could put it to one side and place the others first.*

*Can you find a fraction equivalent to this one?*

*Which fraction card goes with this diagram?*

*How might you express that card in words? Could you express it any other way? Could you make a drawing to represent it?*

Some groups may not manage to place all of the cards and it is not essential that they do so. It is more important that every student learns something from the cards that they try to place.

If a group of students finish placing all the cards and complete all the blank ones, ask them to create additional matching cards, perhaps with some constraints to make the challenge harder:

*Can you make me a set of cards (decimal/percent; fraction; area; scale) that would lie between  $\frac{3}{4}$  and  $\frac{6}{10}$ ?*

*Can you make me a set of cards that would lie exactly half way between  $\frac{1}{20}$  and  $\frac{3}{4}$ ?*

### **Making posters (15 minutes)**

Once students have had a chance to match/order all 4 sets of cards, give them a piece of poster paper and a glue stick and ask them to glue their cards down in the agreed order. On their poster they need to justify their matches. If they changed their mind about the placement of a card(s) during the activity they should be encouraged to include details of this on their poster as well.

### **Extending the lesson over two days**

If you are taking two days to complete the unit it is likely that you will need to end the first lesson part way through the collaborative small-group work. If this is the case, ensure that students glue their ordered cards onto their posters at the end of the first lesson. Then, at the start of the second day, students can review the cards they have already ordered and complete their posters with the remaining card sets.

### **Whole-class discussion (20 minutes)**

Conduct a whole-class discussion about what has been learned and explore the different orders in which the cards have been placed. What methods have students used? Have you noticed some interesting misconceptions? If so, you may want to focus the discussion on these.

Slides P-3 to P-6, which contain the different card sets, may be useful here.

*Can someone tell us a card that they were very sure where to place? Why were you so sure? Who agrees/disagrees? Why?*

*Does anyone have a different way of explaining it?*

*Does anyone have a card that they couldn't place or were very unsure about? Which one? Why? What do other people think?*

*Can someone say which card or cards they have at the far left, lowest, end? What about at the highest end?*

*Which kinds of cards did you find the easiest/hardest to place? Why do you think that was?*

If the class is confident with this work, you could ask more demanding questions:

*Someone suggest a fraction, decimal, or percent that isn't on any of the cards.*

*Which cards will it lie between?*

*Which other representations should go with it? Why?*

Draw out any issues you noticed as students worked on the activity, making specific reference to any misconceptions you noticed. You may want to use the questions in the *Common issues* table to support your discussion.

### **Follow-up lesson: reviewing the assessment task (20 minutes)**

Give each student a copy of the review task, *Fractions, Decimals, and Percents (revisited)*, and their original scripts from the assessment task, *Fractions, Decimals, and Percents*. If you have not added questions to individual pieces of work then write your list of questions on the board. Students should select from this list only those questions they think are appropriate to their own work.

*Look at your original responses and the questions [on the board/written on your script]. Answer these questions and revise your response.*

*Now look at the new task sheet, Fractions, Decimals, and Percents (revisited). Can you use what you have learned to answer these questions?*

Some teachers give this as homework.

Review Copy  
Not for Distribution

## SOLUTIONS

### Assessment task: Fractions, Decimals, and Percents

1. The correct order is: 0.05 (least); 0.125; 0.4; 0.62; 1.05 (greatest)

Watch for students who use an algorithm without understanding. For example, they fill in zeros so that each decimal has an equal length, then compare as if these are whole numbers. This method may give correct answers but does not usually contribute to the understanding of place value.

2. The correct order is:  $\frac{3}{16}$  (least);  $\frac{3}{8}$ ;  $\frac{9}{16}$ ;  $\frac{3}{4}$ ;  $\frac{7}{8}$  (greatest)

One method is to convert them all to sixteenths:  $\frac{3}{16}$ ;  $\frac{6}{16}$ ;  $\frac{9}{16}$ ;  $\frac{12}{16}$ ;  $\frac{14}{16}$ .

3(a) 40% is greater than  $\frac{1}{4}$ . Students might explain this by converting 40% to  $\frac{2}{5}$  or  $\frac{1}{4}$  to 25% or both to decimals. Alternatively they may draw pictures to illustrate.

(b) 0.7 is greater than  $\frac{3}{5}$ . Students might use similar methods.

(c) 0.4 is greater than 33%. Some students might think 33% is  $\frac{1}{3}$ , which is approximately but not exactly true.

### Collaborative task

The answers are given below, from smallest number on the left to largest on the right.

→								
0.05	0.125	0.2	0.375	0.5	0.6	0.75	0.8	1.25
5%	12.5%	20%	37.5%	50%	60%	75%	80%	125%
$\frac{1}{20}$	$\frac{1}{8}$	$\frac{1}{5}$	$\frac{3}{8}$	$\frac{1}{2}$	$\frac{6}{10}$	$\frac{3}{4}$	$\frac{4}{5}$	$\frac{5}{4}$

Shaded answers indicate missing ones that students needed to create for themselves. In the case of  $\frac{1}{5}$  this could be  $\frac{2}{10}$  etc. and for the area representing  $\frac{1}{2}$  and the number line representing  $\frac{3}{8}$  there are many possibilities. Equally there are various possible area cards for 1.25.

**Assessment task: Fractions, Decimals, and Percents (revisited)**

1. The correct order is: 0.04 (least); 0.258; 0.4; 0.52; 1.25 (greatest)

2. The correct order is:  $\frac{1}{4}$  (least);  $\frac{5}{16}$ ;  $\frac{1}{2}$ ;  $\frac{5}{8}$ ;  $\frac{3}{4}$  (greatest)

One method is to convert them all to sixteenths:  $\frac{4}{16}$ ;  $\frac{5}{16}$ ;  $\frac{8}{16}$ ;  $\frac{10}{16}$ ;  $\frac{12}{16}$ .

3(a) 80% is greater than  $\frac{1}{8}$ . Students might explain this by converting 80% to  $\frac{4}{5}$  or  $\frac{1}{8}$  to 12.5% or both to decimals. Alternatively they may draw pictures to illustrate.

(b)  $\frac{3}{4}$  is greater than 0.6. Students might use similar methods.

(c) 0.7 is greater than 7%. Students might use similar methods.

Review Copy  
Not for Distribution

## Fractions, Decimals, and Percents

1. Put the following decimals in order of size, starting with the one with the least value:

0.125      0.4      0.62      1.05      0.05

.....,	.....,	.....,	.....,	.....
<b>Least</b>				<b>Greatest</b>

Explain your method for doing this.

.....

.....

.....

2. Put the following fractions in order of size, starting with the one with the least value:

$\frac{3}{4}$        $\frac{9}{16}$        $\frac{3}{16}$        $\frac{7}{8}$        $\frac{3}{8}$

.....,	.....,	.....,	.....,	.....
<b>Least</b>				<b>Greatest</b>

Explain your method for doing this.

.....

.....

.....

3. Put a check mark in each case to say which number is larger.

Explain your answer each time on the dotted lines underneath.

(a) 40%  or  $\frac{1}{4}$

Explain how you know.

.....

.....

.....

(b) 0.7  or  $\frac{3}{5}$

Explain how you know.

.....

.....

.....

(c) 33%  or 0.4

Explain how you know.

.....

.....

.....

Not for Review Copy  
Distribution



### Card Set A: Decimals and Percents

<b>0.2</b>	<b>0.05</b>	<b>80%</b>
<b>0.375</b>	<b>12.5%</b>	<b>0.75</b>
<b>1.25</b>	<b>50%</b>	<b>%</b>

*Not for Review Copy Distribution*

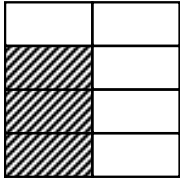
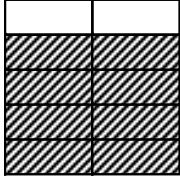
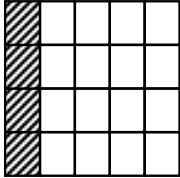
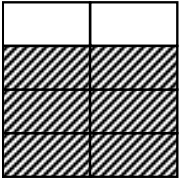
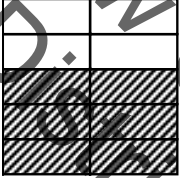
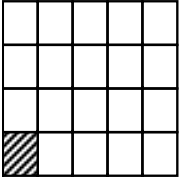
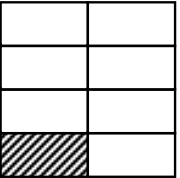

# Card Set B: Areas

Area A 	Area B 	Area C 
Area D 	Area E 	Area F 
Area G 	Area H 	Area I 

Not for Review Copy Distribution

### Card Set C: Fractions

$\frac{3}{8}$	$\frac{4}{5}$	$1\frac{1}{2}$
$\frac{3}{4}$	$\frac{9}{10}$	$5\frac{1}{4}$
$1\frac{1}{8}$		



Not for Review Copy  
Distribution

Student materials

Translating between Fractions, Decimals and Percents  
© 2015 MARS, Shell Center, University of Nottingham

S-5

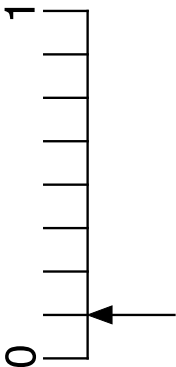
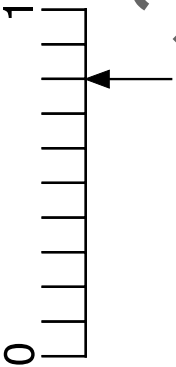
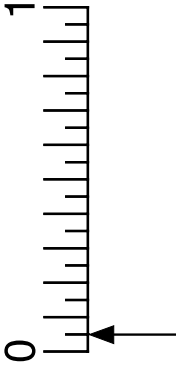
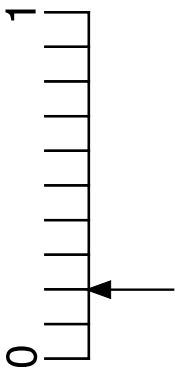
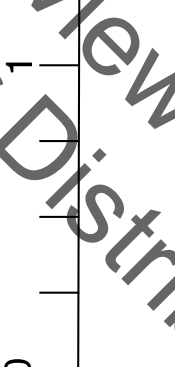
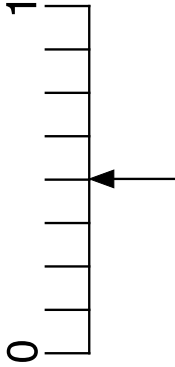
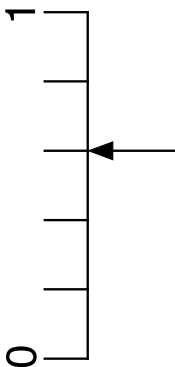
### Card Set D: Scales

<p>Scale A</p> 	<p>Scale B</p> 	<p>Scale C</p> 
<p>Scale D</p> 	<p>Scale E</p> 	<p>Scale F</p> 
<p>Scale G</p> 	<p>Scale H</p> 	<p>Scale I</p> 

Not for Review Copy Distribution

## Fractions, Decimals, and Percents (revisited)

1. Put the following decimals in order of size, starting with the one with the least value:

0.258

0.4

0.52

1.25

0.04

.....,	.....,	.....,	.....,	.....
<b>Least</b>				<b>Greatest</b>

Explain your method for doing this.

.....

.....

.....

2. Put the following fractions in order of size, starting with the one with the least value:

$\frac{5}{16}$

$\frac{1}{2}$

$\frac{3}{4}$

$\frac{5}{8}$

$\frac{1}{4}$

.....,	.....,	.....,	.....,	.....
<b>Least</b>				<b>Greatest</b>

Explain your method for doing this.

.....

.....

.....

3. Put a check mark in each case to say which number is larger.

Explain your answer each time on the dotted lines underneath.

(a) 80%  or  $\frac{1}{8}$

Explain how you know.

.....  
.....  
.....

(b) 0.6  or  $\frac{3}{4}$

Explain how you know.

.....  
.....  
.....

(c) 7%  or 0.7

Explain how you know.

.....  
.....  
.....

Not for Review Copy  
Not for Distribution

## Working Together 1

Take turns to:

1. Fill in the missing decimals and percents.
2. Place a number card where you think it goes on the table, from smallest on the left to largest on the right.
3. Explain your thinking.
4. The other members of your group must check and challenge your explanation if they disagree.
5. Continue until you have placed all the cards in order.
6. Check that you all agree about the order. Move any cards you need to, until everyone in the group is happy with the order.

## Working Together 2

Take turns to:

1. Match each area card to a decimals/percents card.
2. Create a new card or fill in spaces on cards until all the cards have a match.
3. Explain your thinking to your group. The other members of your group must check and challenge your explanation if they disagree.
4. Place your cards in order, from smallest on the left to largest on the right. Check that you all agree about the order. Move any cards you need to, until you are all happy with the order.

# Decimals and Percents

<b>0.2</b>	<b>0.05</b>	<b>80%</b>
<b>0.375</b>	<b>0.75</b>	<b>12.5%</b>
<b>1.25</b>		<b>50%</b>

*Not for Review Distribution*



# Areas

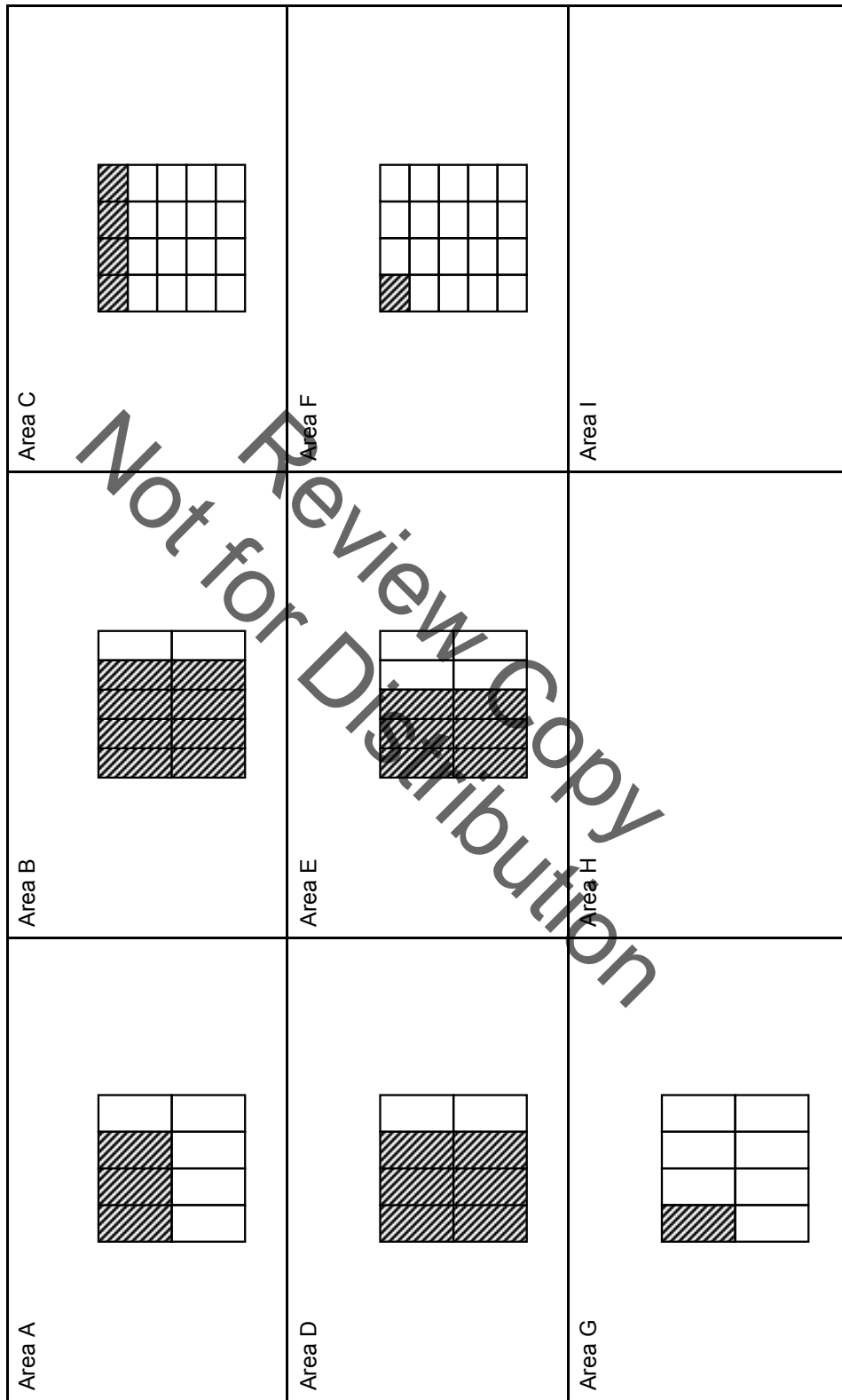

# Fractions

$\frac{3}{8}$	$\frac{4}{5}$	$1\frac{1}{2}$
$\frac{3}{4}$	$\frac{6}{10}$	$5\frac{1}{4}$
$1\frac{1}{8}$		

Not for Review Copy  
Distribution

# Scales

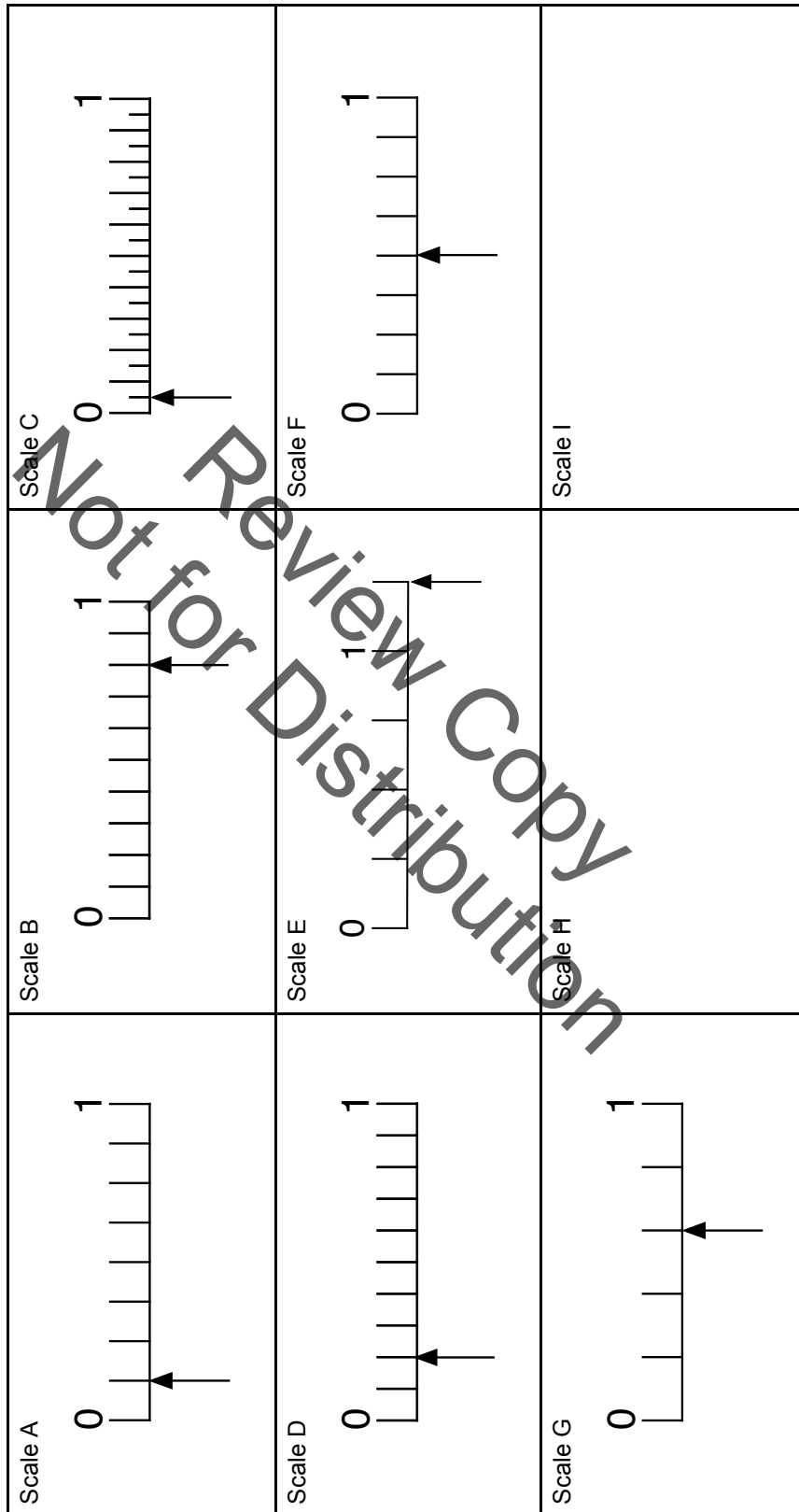

## Mathematics Assessment Project **Classroom Challenges**

These materials were designed and developed by the  
Shell Center Team at the Center for Research in Mathematical Education  
University of Nottingham, England:

**Malcolm Swan,**  
**Nichola Clarke, Clare Dawson, Sheila Evans, Colin Foster, and Marie Joubert**  
with  
**Hugh Burkhardt, Rita Crust, Andy Noyes, and Daniel Pead**

We are grateful to the many teachers and students, in the UK and the US,  
who took part in the classroom trials that played a critical role in developing these materials

The classroom observation teams in the US were led by  
**David Foster, Mary Bouck, and Diane Schaefer**

This project was conceived and directed for  
The Mathematics Assessment Resource Service (MARS) by  
**Alan Schoenfeld** at the University of California, Berkeley, and  
**Hugh Burkhardt, Daniel Pead, and Malcolm Swan** at the University of Nottingham

Thanks also to Mat Crosier, Anne Floyde, Michael Galan, Judith Mills, Nick Orchard, and Alvaro Villanueva who contributed to the design and production of these materials

This development would not have been possible without the support of  
**Bill & Melinda Gates Foundation**

We are particularly grateful to  
**Carina Wong, Melissa Chabran, and Jamie McKee**

The full collection of Mathematics Assessment Project materials is available from

<http://map.mathshell.org>

© 2015 MARS, Shell Center, University of Nottingham  
This material may be reproduced and distributed, without modification, for non-commercial purposes,  
under the Creative Commons License detailed at <http://creativecommons.org/licenses/by-nc-nd/3.0/>  
All other rights reserved.

Please contact [map.info@mathshell.org](mailto:map.info@mathshell.org) if this license does not meet your needs.

## The Number System

# Lesson 5 of 11

## Addressing Misconceptions About Fractions, Decimals and Percents

### Description:

---

Students will be grouped based on misconceptions noted on the post-lesson assessment from the Formative Assessment Lesson: Translating Between Fractions, Decimals and Percents so that they can reflect on mistakes and misconceptions to improve their mathematical understandings. During the lesson they will describe and justify mathematical understanding by constructing viable arguments and critiquing the reasoning of others as they engage in mathematical discourse.

### College- and Career-Readiness Standards Addressed:

---

- EE.7 Solve multi-step real-life and mathematical problems posed with positive and negative rational numbers in any form (whole numbers, fractions, and decimals), using tools strategically. Apply properties of operations to calculate with numbers in any form; convert between forms as appropriate; and assess the reasonableness of answers using mental computation and estimation strategies.

### Process Readiness Indicator(s) Emphasized:

---

- PRI 1: Make sense of problems and persevere in solving through reasoning and exploration
- PRI 2: Reason abstractly and quantitatively by using multiple forms of representations to make sense of and understand mathematics.
- PRI 3: Describe and justify mathematical understandings by constructing viable arguments, critiquing the reasoning of others and engaging in meaningful mathematical discourse.
- PRI 6: Attend to precision.

Sequence of  
Instruction

Activities Checklist

## Engage

Group students based on misconceptions noted on the post-lesson assessment from the Formative Assessment Lesson: Translating Between Fractions, Decimals, and Percents. If possible, students should be grouped with students they did not work with during the Formative Assessment Lesson.

Explain to students they are grouped purposefully and each group will participate in a specific lesson designed to reduce misconceptions and deepen their understanding.

## Explore

PRI 1  
PRI 2  
PRI 3  
PRI 6

### Group #1

*Misconception: Students compare numerators and denominators independently when comparing fractions.*

Instruct students to visit the following website and compare two fractions by modeling them to help them visually see which is bigger and smaller.

[http://www.taw.org.uk/lic/itp/itps/fractions\\_1\\_1.swf](http://www.taw.org.uk/lic/itp/itps/fractions_1_1.swf)

Allow students to pick the fractions that they will compare by rolling four twelve-sided dice. One die will be the denominator of the first fraction. One die will be the numerator of the first fraction. The other two dice will make up the numerator and denominator of the second fraction.

*Teacher's Note: The web site only works for proper fractions. Be sure to instruct students to use proper fractions only.*

### Group #2

*Misconception: Students assume the "length" of a decimal determines its size.*

Instruct students to visit the following web sites to compare various decimals. Students should work in pairs based on similar abilities.

- [https://www.khanacademy.org/math/arithmetic/decimals/comparing-decimals/e/comparing\\_decimals\\_1](https://www.khanacademy.org/math/arithmetic/decimals/comparing-decimals/e/comparing_decimals_1)
- [https://www.khanacademy.org/math/arithmetic/decimals/comparing-decimals/e/comparing\\_decimals\\_2](https://www.khanacademy.org/math/arithmetic/decimals/comparing-decimals/e/comparing_decimals_2)

### Group #3

*Extension: This is for students who showed no weaknesses during the FAL the previous class. Students in this group will use this time to explore equivalent fractions by examining recipes.*

Instruct students to use the Equivalent Fractions – Recipe Activity from the [http://alex.state.al.us/lesson\\_view.php?id=11883](http://alex.state.al.us/lesson_view.php?id=11883) as an example and create their own worksheet.

## Explanation

---

As you circulate to each group (Group #1, Group #2, and Group #3), facilitate whole-group discussions about what processes students have used to complete their tasks as well as what students have learned.

## Practice Together / in Small Groups / Individually

---

### Group #1

Students play Fraction Feud online on Calculation Nation. They can play the “challenge yourself” version or play against a group member in the “challenge others” version.

Directions <http://calculationnation.nctm.org/Games/GameDirections.aspx?GameId=791a122f-bfcb-4b10-9dec-217d5aafb6af>

Game after logged in <http://calculationnation.nctm.org/Games/Game.aspx?GameId=791A122F-BFCB-4B10-9DEC-217D5AAFB6AF>

*Teacher's Note: Students must create a log in to Calculation Nation. It is free.*

### Group #2

Students play [Balloon Pop Math: Decimal Order Level 2](#). This game requires students to pop balloons in order from smallest to largest with various decimals listed on the balloons.

### Group #3

Students individually play the game “Scooter Quest Decimals” at <http://www.sheppardsoftware.com/mathgames/decimals/scooterQuestDecFraction.htm> to practice comparing decimals to fractions.

## Evaluate Understanding

---

Each group will have 3 minutes to report out about what they worked on during the class and what they learned from their lesson. Examples should be used in their presentations.

## Closing Activity

---

Exit Slip:

Each student takes a slip of paper with a fraction written on it and writes the equivalent decimal and percent.

## Independent Practice:

---

For those students having trouble with fractions, use Fractional Clothesline at <http://illuminations.nctm.org/Lesson.aspx?id=2867>

## Resources/Instructional Materials Needed:

---

- Internet access
- Student laptop, computer, or tablet
- 12-sided dice

## The Number System

# Lesson 6 of 11

## Patterns in Scientific Notation

### Description:

---

Students will examine patterns of numbers in scientific notation to develop their own methods as they reason abstractly and quantitatively while using multiple forms of representations. They will look for and express regularity in repeated reasoning and make use of patterns and structure. When appropriate, they will reflect on mistakes and misconceptions as they learn and improve their understanding.

### College- and Career-Readiness Standards Addressed:

---

- EE.10 Use numbers expressed in the form of a single digit times an integer power of 10 to estimate very large or very small quantities, and to express how many times as much one is than the other. For example, estimate the population of the United States as  $3 \times 10^8$  and the population of the world as  $7 \times 10^9$ , and determine that the world population is more than 20 times larger.
- EE.11 Perform operations with numbers expressed in scientific notation, including problems where both decimal and scientific notation are used. Use scientific notation and choose units of appropriate size for measurements of very large or very small quantities (e.g., use millimeters per year for seafloor spreading). Interpret scientific notation that has been generated by technology.

### Process Readiness Indicator(s) Emphasized:

---

- PRI 1: Make sense of problems and persevere in solving through reasoning and exploration
- PRI 2: Reason abstractly and quantitatively by using multiple forms of representations to make sense of and understand mathematics.
- PRI 3: Describe and justify mathematical understandings by constructing viable arguments, critiquing the reasoning of others and engaging in meaningful mathematical discourse.
- PRI 5: Use appropriate tools strategically to support thinking and problem solving.
- PRI 6: Attend to precision.
- PRI 7: Look for and make use of patterns and structure.
- PRI 8: Look for and express regularity in repeated reasoning.
- PRI 9: Demonstrate flexible use of strategies and methods while reflecting on which procedures
- PRI 10: Reflect on mistakes and misconceptions to improve mathematical understanding.



Sequence of  
Instruction

Activities Checklist

## Engage

### PRI 3

Ask students:

1. Have you ever thought about how much money is spent in countries each year? Think about everything you buy, everything your friends buy and everything your families buy. How much do you think that would be?
2. How much do you think the United States spends in one year as a whole?

Chart students' responses to the second question on the board.

Explain to students the amount of money spent on goods and services in a country is called the Gross Domestic Product. We abbreviate it to GDP.

Instruct students to visit <http://data.worldbank.org/indicator/NY.GDP.MKTP.CD> and pick three countries other than the United States for the following questions (this data is also found at the end of this lesson in pdf form):

INCLUDED IN THE STUDENT MANUAL

#### Task #5: Gross Domestic Product Data

1. What is the difference between the GDP of the United States and each of the three countries you chose?
2. If you added up the GDP of the three countries you chose, how much is the difference between that amount and the United States?
3. Put the GDP of the three countries in order from least to greatest.

Allow students 5-10 minutes to collect their information and answer the questions.

Group students in pairs based on similar abilities. Ask students:

- Was it hard to add and subtract such large numbers? Talk to your partner about the strategies you used to find the answers to the three questions above.

Select three student groups to share their strategies with the whole class.

## Explore

### PRI 1

Explain it can be easier to deal with very large (or very small) numbers when we use scientific notation.

### PRI 2

### PRI 3

Group students into pairs and have students examine the following equations:

### PRI 5

$$2.00 \times 10^3 = 2000$$

### PRI 6

$$2.00 \times 10^2 = 200$$

### PRI 7

$$2.00 \times 10^1 = 20$$

### PRI 8

$$2.00 \times 10^0 = 2$$

### PRI 9

$$2.00 \times 10^{-1} = 0.2$$

### PRI10

$$2.00 \times 10^{-2} = 0.02$$

$$2.00 \times 10^{-3} = 0.002$$

Each pair of students should examine the pattern and answer the following questions:

- What pattern do you see?
- What is the value of  $10^0$ ?

Instruct each pair of students to:

- Develop a method for finding the scientific notation form of any number.
- Create a poster explaining your method including examples to prove your method works with numbers other than the examples.
- Share your method with at least two other groups.
- Consider the following questions:
  - Do the methods developed by the other groups work? Why or why not?
  - Which method is the most efficient? Why?

*Teacher Notes: As students work on their methods, talk to each group and determine their misconceptions. Do not tell them any shortcuts that you already know. Allow the groups to develop their own methods using the pattern.*

Once all the groups have had a chance to compare their methods with two other groups, give them sample problems and make sure that each group can accurately find the scientific notation form of a number.

Here are some sample numbers:

345,987

4500

0.789

0.0054

1.987

3

0.5

## Explanation

### PRI 3

Choose three groups and allow them to share their methods with the rest of the class as they discuss their answers. Facilitate a whole-class discussion about which method is the most efficient and why.

Explain to students scientific notation is used when numbers are either very large or very small. Knowing when to use scientific notation is important. For example, when comparing the GDP of various countries, it is very appropriate to convert those numbers to scientific notation. However, it would not be appropriate to use scientific notation when comparing smaller numbers such as someone's weight or the prices of everyday objects such as cars, televisions or clothing.

## Practice Together / in Small Groups / Individually

Students will match numbers with their equivalent form in scientific notation at <http://algebra-regentsprep.wikispaces.com/Scientific+Notation>



## GDP Data

Country Name	2012	2013	2014
Afghanistan	\$ 20,536,542,736.73	\$ 20,458,939,155.27	\$ 20,038,215,159.39
Albania	\$ 12,319,784,787.14	\$ 12,781,029,643.42	\$ 13,211,513,725.59
Arab World	\$ 2,753,999,680,390.12	\$ 2,827,557,148,210.97	\$ 2,845,788,040,651.82
United Arab Emirates	\$ 373,429,543,907.42	\$ 387,192,103,471.75	\$ 399,451,327,433.63
Argentina	\$ 604,378,456,915.58	\$ 614,383,517,369.50	\$ 537,659,972,702.09
Armenia	\$ 10,619,320,048.59	\$ 11,121,465,767.41	\$ 11,644,438,422.98
Antigua and Barbuda	\$ 1,204,713,111.11	\$ 1,200,587,518.52	\$ 1,220,976,011.11
Australia	\$ 1,537,477,830,480.51	\$ 1,563,950,959,269.52	\$ 1,454,675,479,665.84
Austria	\$ 407,373,026,611.61	\$ 428,698,577,647.39	\$ 436,887,543,466.95
Azerbaijan	\$ 68,730,906,313.65	\$ 73,560,484,384.96	\$ 75,198,010,965.19
Burundi	\$ 2,472,384,907.00	\$ 2,714,505,634.53	\$ 3,093,647,226.81
Belgium	\$ 497,780,014,247.47	\$ 521,402,393,365.01	\$ 531,546,586,178.58
Benin	\$ 8,117,100,933.53	\$ 9,110,800,744.88	\$ 9,575,356,734.73
Burkina Faso	\$ 11,166,061,507.80	\$ 12,110,243,992.07	\$ 12,542,221,941.86
Bangladesh	\$ 133,355,749,482.48	\$ 149,990,451,022.29	\$ 172,886,567,164.18
Bulgaria	\$ 53,576,670,827.86	\$ 55,626,359,256.24	\$ 56,717,054,673.72
Bahrain	\$ 30,756,462,765.96	\$ 32,897,606,382.98	\$ 33,851,063,829.79
Bahamas, The	\$ 8,234,470,000.00	\$ 8,431,750,000.00	\$ 8,510,500,000.00
Bosnia and Herzegovina	\$ 16,906,005,781.11	\$ 17,841,444,572.67	\$ 18,286,273,232.94
Belarus	\$ 63,615,445,566.85	\$ 73,097,619,636.82	\$ 76,139,250,364.52
Belize	\$ 1,573,867,300.00	\$ 1,624,294,250.00	\$ 1,699,154,132.06
Bolivia	\$ 27,084,497,539.80	\$ 30,659,338,929.09	\$ 32,996,187,988.42
Brazil	\$ 2,413,135,528,134.76	\$ 2,392,082,463,707.62	\$ 2,346,076,315,118.55
Barbados	\$ 4,313,000,000.00	\$ 4,281,000,000.00	\$ 4,354,500,000.00
Brunei Darussalam	\$ 16,953,505,121.64	\$ 16,110,693,734.02	\$ 17,104,656,669.30
Bhutan	\$ 1,823,692,109.62	\$ 1,798,333,725.84	\$ 1,958,803,866.95
Botswana	\$ 14,792,386,725.47	\$ 14,979,304,170.78	\$ 15,813,364,345.32
Central African Republic	\$ 2,169,706,564.06	\$ 1,537,740,105.46	\$ 1,722,529,061.42
Canada	\$ 1,832,715,597,431.65	\$ 1,838,964,175,409.41	\$ 1,785,386,649,602.19
Central Europe and the Baltics	\$ 1,349,251,615,979.45	\$ 1,419,383,888,513.92	\$ 1,457,322,987,324.99
Switzerland	\$ 665,408,300,271.74	\$ 684,919,206,141.13	\$ 701,037,135,966.05
Chile	\$ 265,231,582,107.40	\$ 276,673,695,234.34	\$ 258,061,522,886.53
China	\$ 8,461,623,162,714.07	\$ 9,490,602,600,148.49	\$ 10,354,831,729,340.40
Cote d'Ivoire	\$ 27,040,562,587.18	\$ 31,292,560,974.45	\$ 34,253,607,832.41
Cameroon	\$ 26,472,056,037.77	\$ 29,567,504,655.49	\$ 32,050,817,632.96
Congo, Rep.	\$ 13,677,930,123.59	\$ 14,085,852,120.48	\$ 14,177,440,494.82
Colombia	\$ 369,659,700,375.52	\$ 380,063,456,192.64	\$ 377,739,622,865.84
Comoros	\$ 550,476,566.06	\$ 598,925,539.67	\$ 623,751,049.73
Cabo Verde	\$ 1,751,888,561.73	\$ 1,837,908,563.30	\$ 1,871,187,071.00
Costa Rica	\$ 45,300,669,857.48	\$ 49,236,710,394.45	\$ 49,552,580,683.15
Caribbean small states	\$ 66,505,519,500.70	\$ 69,287,048,038.15	\$ 71,288,024,078.60
Cyprus	\$ 24,940,600,822.11	\$ 24,057,251,748.56	\$ 23,226,158,986.17
Czech Republic	\$ 206,441,578,342.49	\$ 208,328,435,108.82	\$ 205,269,709,743.47
Germany	\$ 3,539,615,377,794.51	\$ 3,745,317,149,399.13	\$ 3,868,291,231,823.77
Djibouti	\$ 1,353,632,941.52	\$ 1,455,416,073.51	\$ 1,589,026,157.88
Dominica	\$ 485,185,185.19	\$ 506,666,666.67	\$ 524,074,074.07
Denmark	\$ 322,276,544,469.31	\$ 335,877,548,363.83	\$ 342,362,478,767.51
Dominican Republic	\$ 60,595,109,805.12	\$ 61,366,326,096.19	\$ 64,137,819,040.49
Algeria	\$ 209,047,389,599.67	\$ 209,703,529,364.33	\$ 213,518,488,688.12
East Asia & Pacific (developing only)	\$ 10,649,494,095,547.20	\$ 11,729,395,514,462.00	\$ 12,609,716,376,487.10
East Asia & Pacific (all income levels)	\$ 20,643,769,618,337.50	\$ 20,846,726,977,065.70	\$ 21,452,948,649,513.30
Europe & Central Asia (developing only)	\$ 1,750,766,182,639.54	\$ 1,879,644,696,323.62	\$ 1,817,225,993,582.48
Europe & Central Asia (all income levels)	\$ 22,006,778,830,664.60	\$ 22,949,899,696,925.60	\$ 23,182,545,677,138.90

Country Name	2012	2013	2014
Ecuador	\$ 87,924,544,000.00	\$ 94,776,170,000.00	\$ 100,917,372,000.00
Egypt, Arab Rep.	\$ 262,824,255,567.60	\$ 271,972,822,883.38	\$ 286,538,047,765.90
Euro area	\$ 12,636,217,395,544.50	\$ 13,188,775,741,580.40	\$ 13,410,232,162,147.30
Spain	\$ 1,339,946,773,437.24	\$ 1,369,261,671,179.00	\$ 1,381,342,101,735.68
Estonia	\$ 23,135,266,649.13	\$ 25,246,787,741.95	\$ 26,485,161,115.94
Ethiopia	\$ 43,310,721,414.08	\$ 47,648,211,133.22	\$ 55,612,228,233.52
European Union	\$ 17,248,798,723,694.40	\$ 17,987,465,273,840.30	\$ 18,514,155,872,554.50
Fragile and conflict affected situations	\$ 722,861,462,233.95	\$ 731,558,071,200.60	\$ 723,672,091,148.52
Finland	\$ 256,706,466,091.09	\$ 269,190,106,004.86	\$ 272,216,575,502.25
Fiji	\$ 3,977,652,382.81	\$ 4,196,100,792.87	\$ 4,531,817,940.97
France	\$ 2,681,416,108,537.39	\$ 2,810,249,215,589.07	\$ 2,829,192,039,171.84
Micronesia, Fed. Sts.	\$ 325,835,160.29	\$ 315,725,616.96	\$ 318,071,978.58
Gabon	\$ 17,171,447,372.33	\$ 17,590,716,232.49	\$ 18,179,717,776.16
United Kingdom	\$ 2,630,472,981,169.65	\$ 2,712,296,271,989.99	\$ 2,988,893,283,565.20
Georgia	\$ 15,846,474,595.77	\$ 16,140,047,012.14	\$ 16,529,963,187.40
Ghana	\$ 41,939,728,978.73	\$ 47,805,069,494.91	\$ 38,616,536,131.65
Guinea	\$ 5,667,229,758.99	\$ 6,231,725,484.56	\$ 6,624,068,015.50
Guinea-Bissau	\$ 958,857,944.22	\$ 946,629,755.79	\$ 1,022,371,991.53
Equatorial Guinea	\$ 18,011,041,667.13	\$ 17,135,584,684.64	\$ 15,529,729,676.69
Greece	\$ 245,670,666,639.05	\$ 239,509,850,570.45	\$ 235,574,074,998.31
Grenada	\$ 799,882,130.00	\$ 842,571,332.22	\$ 911,803,790.37
Guatemala	\$ 50,388,460,222.63	\$ 53,851,148,431.93	\$ 58,827,085,046.95
Guyana	\$ 2,851,149,182.59	\$ 2,982,036,493.73	\$ 3,096,747,286.98
High income	\$ 51,595,926,314,026.60	\$ 52,256,187,329,042.10	\$ 52,812,577,414,531.50
Hong Kong SAR, China	\$ 262,629,441,493.48	\$ 275,742,650,850.95	\$ 290,895,784,165.80
Honduras	\$ 18,528,601,901.32	\$ 18,496,438,641.48	\$ 19,385,314,718.41
Heavily indebted poor countries (HIPC)	\$ 551,529,245,465.13	\$ 598,851,845,291.30	\$ 630,954,045,632.17
Croatia	\$ 56,485,301,967.42	\$ 57,770,884,728.65	\$ 57,113,389,357.45
Haiti	\$ 7,890,216,807.69	\$ 8,452,718,010.08	\$ 8,713,041,022.95
Hungary	\$ 127,176,184,359.09	\$ 134,401,774,737.92	\$ 138,346,669,914.95
Indonesia	\$ 917,869,913,364.90	\$ 910,478,729,099.04	\$ 888,538,201,025.35
India	\$ 1,831,781,515,472.09	\$ 1,861,801,615,477.85	\$ 2,048,517,438,873.54
Ireland	\$ 224,652,132,155.01	\$ 238,259,956,626.79	\$ 250,813,607,686.11
Iran, Islamic Rep.	\$ 587,209,369,682.67	\$ 511,620,875,086.78	\$ 425,326,068,422.88
Iraq	\$ 218,000,986,222.64	\$ 232,497,236,277.87	\$ 223,508,094,682.68
Iceland	\$ 14,194,519,025.26	\$ 15,376,604,281.45	\$ 17,036,097,481.81
Israel	\$ 259,613,579,190.33	\$ 292,408,330,563.86	\$ 305,674,837,195.00
Italy	\$ 2,074,631,555,455.23	\$ 2,133,539,300,229.70	\$ 2,141,161,325,367.43
Jamaica	\$ 14,746,420,946.17	\$ 14,187,446,660.71	\$ 13,891,359,467.72
Jordan	\$ 30,937,277,605.63	\$ 33,593,843,661.97	\$ 35,826,925,774.65
Japan	\$ 5,954,476,603,961.52	\$ 4,919,563,108,372.50	\$ 4,601,461,206,885.08
Kazakhstan	\$ 203,517,198,088.69	\$ 231,876,282,133.87	\$ 217,872,250,221.41
Kenya	\$ 50,410,164,013.55	\$ 54,930,813,987.92	\$ 60,936,509,777.96
Kyrgyz Republic	\$ 6,605,139,933.41	\$ 7,335,027,591.92	\$ 7,404,412,710.31
Cambodia	\$ 14,038,383,450.19	\$ 15,449,630,418.55	\$ 16,777,820,332.71
Kiribati	\$ 174,984,468.83	\$ 168,951,535.05	\$ 166,756,805.48
St. Kitts and Nevis	\$ 731,919,906.04	\$ 787,290,366.87	\$ 852,203,083.88
Korea, Rep.	\$ 1,222,807,195,712.49	\$ 1,305,604,981,271.91	\$ 1,410,382,988,616.48
Kosovo	\$ 6,500,321,212.90	\$ 7,073,021,773.77	\$ 7,386,758,657.29
Kuwait	\$ 174,070,025,008.93	\$ 174,161,495,063.47	\$ 163,612,438,510.19
Latin America & Caribbean (developing only)	\$ 4,655,107,670,668.17	\$ 4,761,014,358,771.96	\$ 4,774,530,077,043.51
Lao PDR	\$ 9,359,185,244.25	\$ 11,192,471,435.44	\$ 11,997,062,176.69
Lebanon	\$ 43,205,095,854.06	\$ 44,352,418,120.46	\$ 45,730,945,273.63

Country Name	2012	2013	2014
Liberia	\$ 1,735,500,000.00	\$ 1,946,500,000.00	\$ 2,013,000,000.00
Libya	\$ 81,905,365,776.33	\$ 65,509,594,212.02	\$ 41,142,722,414.34
St. Lucia	\$ 1,311,133,139.59	\$ 1,334,385,778.15	\$ 1,404,430,563.81
Latin America & Caribbean (all income levels)	\$ 6,121,616,478,548.56	\$ 6,269,874,859,706.83	\$ 6,181,225,663,720.57
Least developed countries: UN classification	\$ 768,195,368,163.27	\$ 816,890,155,603.36	\$ 888,054,229,547.29
Low income	\$ 342,556,331,364.33	\$ 372,061,684,704.11	\$ 398,567,364,161.38
Sri Lanka	\$ 68,434,422,593.76	\$ 74,317,814,502.32	\$ 78,823,610,056.93
Lower middle income	\$ 5,270,833,310,432.87	\$ 5,473,342,620,945.17	\$ 5,765,816,087,352.00
Low & middle income	\$ 22,596,490,522,207.20	\$ 24,011,494,861,267.10	\$ 25,063,122,781,869.40
Lesotho	\$ 2,384,043,848.96	\$ 2,218,102,350.05	\$ 2,181,300,505.86
Lithuania	\$ 42,852,204,396.45	\$ 46,412,093,986.46	\$ 48,353,937,110.26
Luxembourg	\$ 55,986,712,367.80	\$ 61,794,506,555.51	\$ 64,873,963,098.49
Latvia	\$ 28,023,276,371.58	\$ 30,241,650,059.78	\$ 31,286,809,075.23
Macao SAR, China	\$ 42,991,714,539.61	\$ 51,313,531,848.85	\$ 55,501,734,046.15
Morocco	\$ 98,266,306,615.36	\$ 107,316,974,437.74	\$ 110,009,040,838.42
Moldova	\$ 7,284,686,576.28	\$ 7,985,349,731.46	\$ 7,962,423,551.54
Madagascar	\$ 9,919,780,071.29	\$ 10,613,473,832.74	\$ 10,593,147,380.73
Maldives	\$ 2,514,041,557.49	\$ 2,790,659,901.12	\$ 3,061,829,144.68
Middle East & North Africa (all income levels)	\$ 3,536,261,119,467.85	\$ 3,562,279,554,744.38	\$ 3,496,997,634,326.72
Mexico	\$ 1,184,499,844,413.23	\$ 1,258,773,797,056.06	\$ 1,294,689,733,233.03
Marshall Islands	\$ 184,439,555.47	\$ 190,180,248.29	\$ 186,716,625.75
Middle income	\$ 22,251,429,741,874.90	\$ 23,637,119,652,152.10	\$ 24,662,352,613,439.10
Macedonia, FYR	\$ 9,745,251,126.01	\$ 10,767,448,426.89	\$ 11,323,769,141.48
Mali	\$ 10,340,795,746.54	\$ 10,942,822,487.19	\$ 12,037,229,619.42
Middle East & North Africa (developing only)	\$ 1,690,104,537,680.94	\$ 1,640,224,832,654.45	\$ 1,541,137,033,404.35
Montenegro	\$ 4,087,125,812.67	\$ 4,464,260,488.58	\$ 4,587,928,884.17
Mongolia	\$ 12,292,770,631.23	\$ 12,545,217,934.42	\$ 12,015,944,336.55
Mozambique	\$ 14,534,278,446.31	\$ 16,018,848,990.67	\$ 15,938,468,562.50
Mauritania	\$ 4,845,165,274.16	\$ 5,057,754,938.61	\$ 5,061,180,371.05
Mauritius	\$ 11,445,657,237.94	\$ 11,931,866,299.26	\$ 12,630,332,836.95
Malawi	\$ 4,240,491,999.36	\$ 3,883,521,174.80	\$ 4,258,033,615.30
Malaysia	\$ 314,442,825,692.83	\$ 323,342,854,422.55	\$ 338,103,822,298.27
North America	\$ 18,001,411,134,431.70	\$ 18,612,590,885,409.40	\$ 19,210,139,300,922.00
Namibia	\$ 13,016,447,844.09	\$ 12,754,875,754.78	\$ 12,995,241,138.15
Niger	\$ 6,942,209,594.55	\$ 7,683,045,042.91	\$ 8,168,695,869.87
Nigeria	\$ 460,953,836,444.36	\$ 514,964,650,436.05	\$ 568,508,262,377.80
Nicaragua	\$ 10,460,339,389.38	\$ 10,850,733,052.08	\$ 11,805,641,286.80
Netherlands	\$ 828,946,812,396.79	\$ 864,169,242,952.93	\$ 879,319,321,494.64
High income: nonOECD	\$ 6,175,491,995,936.56	\$ 6,369,893,151,799.64	\$ 6,111,980,956,657.77
Norway	\$ 509,704,856,037.82	\$ 522,349,106,382.98	\$ 499,817,138,323.20
Nepal	\$ 18,851,513,891.07	\$ 19,271,168,018.48	\$ 19,769,642,122.58
High income: OECD	\$ 45,452,373,870,790.80	\$ 45,927,311,632,922.50	\$ 46,711,200,072,078.80
OECD members	\$ 47,425,862,079,709.50	\$ 48,009,763,073,164.40	\$ 48,804,675,844,961.70
Oman	\$ 76,341,482,444.73	\$ 78,182,574,772.43	\$ 81,796,618,985.70
Other small states	\$ 98,381,559,591.03	\$ 99,004,463,561.96	\$ 100,552,408,034.02
Pakistan	\$ 224,646,134,571.40	\$ 231,086,513,914.87	\$ 243,631,917,866.48
Panama	\$ 37,956,200,000.00	\$ 42,648,100,000.00	\$ 46,212,600,000.00
Peru	\$ 192,679,697,094.17	\$ 201,848,484,663.51	\$ 202,596,307,719.12
Philippines	\$ 250,092,093,547.53	\$ 271,927,428,132.55	\$ 284,777,093,019.07
Palau	\$ 215,815,865.59	\$ 228,567,644.08	\$ 250,625,562.79
Papua New Guinea	\$ 15,391,629,871.38	\$ 15,413,232,345.73	\$ 16,928,577,232.47
Poland	\$ 500,227,851,988.33	\$ 524,059,039,422.89	\$ 544,966,555,714.06
Portugal	\$ 216,368,178,659.45	\$ 226,073,492,966.50	\$ 230,116,912,513.59

Country Name	2012	2013	2014
Paraguay	\$ 24,611,039,786.13	\$ 29,078,927,134.81	\$ 30,880,859,579.51
Pacific island small states	\$ 7,986,838,125.01	\$ 8,227,972,578.75	\$ 8,699,784,931.29
Qatar	\$ 190,289,835,164.84	\$ 201,885,439,560.44	\$ 210,109,065,934.07
Romania	\$ 172,043,567,268.32	\$ 191,587,217,163.98	\$ 199,043,652,215.45
Russian Federation	\$ 2,016,112,133,645.48	\$ 2,079,024,782,973.32	\$ 1,860,597,922,763.44
Rwanda	\$ 7,219,657,132.22	\$ 7,522,006,198.23	\$ 7,890,190,336.75
South Asia	\$ 2,301,943,612,414.63	\$ 2,361,515,495,718.04	\$ 2,588,688,024,254.73
Saudi Arabia	\$ 733,955,733,333.33	\$ 744,335,733,333.33	\$ 746,248,533,333.33
Sudan	\$ 62,688,889,672.54	\$ 66,480,141,187.35	\$ 73,814,947,340.90
Senegal	\$ 14,045,681,414.37	\$ 14,951,667,193.55	\$ 15,657,551,477.20
Singapore	\$ 289,935,584,540.29	\$ 302,245,904,259.57	\$ 307,859,758,503.67
Solomon Islands	\$ 1,025,124,684.36	\$ 1,059,690,062.43	\$ 1,158,183,053.76
Sierra Leone	\$ 3,740,395,424.17	\$ 4,838,115,453.12	\$ 4,837,512,587.35
El Salvador	\$ 23,813,600,000.00	\$ 24,350,900,000.00	\$ 25,163,700,000.00
Serbia	\$ 40,742,313,861.14	\$ 45,519,650,911.41	\$ 43,866,423,166.94
Sub-Saharan Africa (developing only)	\$ 1,563,441,527,310.93	\$ 1,649,422,075,764.72	\$ 1,729,214,909,241.65
South Sudan	\$ 10,368,813,559.32	\$ 13,257,635,693.01	\$ 13,282,084,041.62
Sub-Saharan Africa (all income levels)	\$ 1,582,711,920,242.48	\$ 1,668,119,248,410.01	\$ 1,746,140,688,213.95
Small states	\$ 172,873,917,216.74	\$ 176,519,484,178.87	\$ 180,546,705,730.21
Sao Tome and Principe	\$ 265,592,759.79	\$ 305,632,896.59	\$ 337,413,478.15
Suriname	\$ 4,980,000,000.00	\$ 5,130,909,090.91	\$ 5,210,303,030.30
Slovak Republic	\$ 93,049,721,684.12	\$ 98,033,841,689.22	\$ 100,248,607,784.10
Slovenia	\$ 46,239,997,124.66	\$ 47,675,804,618.00	\$ 49,491,440,620.37
Sweden	\$ 543,880,647,757.40	\$ 578,742,001,487.57	\$ 571,090,480,171.00
Swaziland	\$ 4,912,817,411.96	\$ 4,562,432,045.38	\$ 4,412,891,830.03
Seychelles	\$ 1,134,239,543.20	\$ 1,411,035,753.70	\$ 1,422,608,276.10
Chad	\$ 12,368,070,168.97	\$ 12,949,853,281.25	\$ 13,922,224,560.79
Togo	\$ 3,915,776,459.27	\$ 4,338,575,823.82	\$ 4,518,443,476.63
Thailand	\$ 397,471,809,439.86	\$ 420,166,569,029.49	\$ 404,823,952,117.93
Tajikistan	\$ 7,633,036,366.04	\$ 8,506,615,265.14	\$ 9,241,627,840.61
Turkmenistan	\$ 35,164,210,526.32	\$ 41,012,982,456.14	\$ 47,931,929,824.56
Timor-Leste	\$ 1,295,000,000.00	\$ 1,319,000,000.00	\$ 1,417,000,000.00
Tonga	\$ 457,244,315.21	\$ 432,893,161.19	\$ 434,380,116.96
Trinidad and Tobago	\$ 24,580,844,842.60	\$ 27,257,473,690.75	\$ 28,882,663,253.84
Tunisia	\$ 45,131,250,400.15	\$ 46,920,723,825.94	\$ 48,612,652,412.09
Turkey	\$ 788,863,301,670.38	\$ 823,242,587,404.14	\$ 798,429,233,036.33
Tuvalu	\$ 39,875,750.67	\$ 38,322,359.53	\$ 37,859,550.40
Tanzania	\$ 39,087,748,240.44	\$ 44,384,603,619.54	\$ 48,056,680,982.15
Uganda	\$ 23,236,898,742.13	\$ 24,662,957,430.38	\$ 26,998,477,288.85
Ukraine	\$ 175,781,379,051.43	\$ 183,310,146,378.08	\$ 131,805,126,738.29
Upper middle income	\$ 16,972,931,446,091.30	\$ 18,155,014,821,574.90	\$ 18,887,373,566,891.70
Uruguay	\$ 51,384,870,651.20	\$ 57,524,653,093.51	\$ 57,471,030,095.37
United States	\$ 16,163,158,000,000.00	\$ 16,768,053,000,000.00	\$ 17,419,000,000,000.00
Uzbekistan	\$ 51,183,443,224.99	\$ 56,795,656,324.58	\$ 62,643,953,021.76
St. Vincent and the Grenadines	\$ 692,933,757.41	\$ 720,636,189.63	\$ 729,309,384.44
Vietnam	\$ 155,820,001,920.49	\$ 171,222,025,390.00	\$ 186,204,652,922.26
Vanuatu	\$ 781,702,874.11	\$ 801,787,555.86	\$ 814,954,306.97
West Bank and Gaza	\$ 11,262,141,134.37	\$ 12,473,235,848.01	\$ 12,737,613,125.02
World	\$ 74,154,982,300,295.00	\$ 76,236,796,175,538.20	\$ 77,845,107,169,905.00
Samoa	\$ 804,163,067.66	\$ 795,753,602.49	\$ 800,418,989.62
South Africa	\$ 397,386,418,270.40	\$ 366,243,783,486.35	\$ 350,085,020,840.25
Congo, Dem. Rep.	\$ 27,463,220,379.99	\$ 30,014,905,126.10	\$ 33,121,070,959.39
Zambia	\$ 24,939,314,028.71	\$ 26,820,806,278.84	\$ 27,066,230,009.10
Zimbabwe	\$ 12,392,715,461.99	\$ 13,490,227,100.00	\$ 14,196,912,534.63

## The Number System

# Lesson 7 of 11

## Scientific Notation in Context

### Description:

---

Students will make sense of problems and persevere in solving them through reasoning and exploration as they add, subtract, multiply and divide numbers in scientific notation and apply these operations to real-world problems. They will describe and justify mathematical understandings by constructing viable arguments and engage with others in meaningful discourse.

### College- and Career-Readiness Standards Addressed:

---

- EE.10 Use numbers expressed in the form of a single digit times an integer power of 10 to estimate very large or very small quantities, and to express how many times as much one is than the other. *For example, estimate the population of the United States as  $3 \times 10^8$  and the population of the world as  $7 \times 10^9$ , and determine that the world population is more than 20 times larger.*
- EE.11 Perform operations with numbers expressed in scientific notation, including problems where both decimal and scientific notation are used. Use scientific notation and choose units of appropriate size for measurements of very large or very small quantities (e.g., use millimeters per year for seafloor spreading). Interpret scientific notation that has been generated by technology.

### Process Readiness Indicator(s) Emphasized:

---

- PRI 1: Make sense of problems and persevere in solving through reasoning and exploration
- PRI 2: Reason abstractly and quantitatively by using multiple forms of representations to make sense of and understand mathematics.
- PRI 3: Describe and justify mathematical understandings by constructing viable arguments, critiquing the reasoning of others and engaging in meaningful mathematical discourse.
- PRI 6: Attend to precision.
- PRI 7: Look for and make use of patterns and structure.



Sequence of Instruction

Activities Checklist

Engage

Play the Star Size Comparison Video at <https://www.youtube.com/watch?v=HEehh1BH34Q>

*Teacher's Note: This video will be used as a starting point to talk about comparing numbers using scientific notation.*

Explore

- PRI 1
- PRI 2
- PRI 3
- PRI 6
- PRI 7

Explain to students the numbers below represent the diameters of the planets in our solar system, Pluto, and the Sun. Ask students to work with a partner to compare each set of numbers and determine which is larger. Students should provide a written explanation for each problem.

INCLUDED IN THE STUDENT MANUAL

**Task #6: Diameters of Planets**

Work with a partner to compare each set of numbers and determine which is larger. Provide a written explanation for each problem.

1.  $1.39822 \times 10^8$  m      or       $5.0724 \times 10^7$  m

2.  $4.9248 \times 10^7$  m      or       $1.16464 \times 10^8$  m

3.  $2.4 \times 10^6$  m      or       $4.878 \times 10^6$  m

4.  $1.392684 \times 10^9$  m      or       $1.39822 \times 10^8$  m

5.  $6.78 \times 10^6$  m      or       $5.0724 \times 10^7$  m

6.  $1.2756 \times 10^7$  m      or       $1.2104 \times 10^7$  m

Ask students to compare their answers with another group.

- How was the other group's method different than yours?
- Which method was more efficient?

*Teacher's Note: As students work on their methods, talk to each group and determine their misconceptions. Do not tell them any shortcuts that you already know.*

Select three groups to share their methods with the rest of the class as students discuss the correct answers. Facilitate a whole-class discussion about how to compare the numbers.

INCLUDED IN THE STUDENT MANUAL

### Task #7: Size Matters: An Examination of Planets and Stars

Below are the planets in our solar system (including Pluto) in alphabetical order. The numbers beside each planet name is the diameter of the planet in meters. Rearrange the order of the planets so that they are arranged from the smallest diameter to the largest diameter.

Earth:  $1.28 \times 10^7$   
Mars:  $6.79 \times 10^6$   
Mercury:  $4.88 \times 10^6$   
Jupiter:  $1.43 \times 10^8$   
Neptune:  $4.95 \times 10^7$   
Pluto:  $2.37 \times 10^6$   
Saturn:  $1.21 \times 10^8$   
Uranus:  $5.11 \times 10^7$   
Venus:  $1.21 \times 10^7$

Select two or three groups to share their methods with the rest of the class as students discuss the correct answers.

Ant and Elephant retrieved from <https://www.illustrativemathematics.org/content-standards/tasks/476> on 05/21/2014.

Students will work with their partner to answer the question below.

INCLUDED IN THE STUDENT MANUAL

### Task #8: Ant and Elephant

1. An ant has a mass of approximately  $4 \times 10^{-3}$  grams and an elephant has a mass of approximately 8 metric tons. How many ants does it take to have the same mass as an elephant? (Note: 1 kg = 1000 grams, 1 metric ton = 1000 kg, 1 m = 100 cm, 1 km = 1000 m)

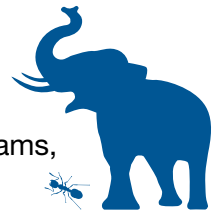

When groups are finished, instruct them to compare their answer with another group. Students should consider:

- Did your group use the same method?
- If not, which one is more efficient?

*Teacher's Note: As you talk to groups, you may find that some students will need help. Be sure to use guiding questions, but do not give them explicit instructions at this point. One example of a question would be "How can you use what you know about decimals to solve this problem?"*

Once the groups have determined an answer and compared with another group, give them the rest of the task:

INCLUDED IN THE STUDENT MANUAL

2. An ant is  $10^{-1}$  cm long. If you put all these ants from your answer to part (a) in a line (front to back), how long would the line be?
3. Find two cities in the United States that are a similar distance apart to illustrate this length.

*Teacher's Note: The complete task can be found here:*

<https://www.illustrativemathematics.org/content-standards/tasks/476>

## Explanation

Scientific numbers are very useful when working with very large or very small numbers. When adding or subtracting numbers in scientific notation, the numbers must be the same magnitude.

Example: To add  $2.57 \times 10^2$  to  $3.45 \times 10^4$ , you must change one of the numbers.

So, change  $3.45 \times 10^4$  to  $345 \times 10^2$

Now, you can add them using the distributive property:

$$2.57 \times 10^2 + 345 \times 10^2 = (2.57 + 345) \times 10^2 = 347.57 \times 10^2$$

Rewrite the answer as  $3.4757 \times 10^4$

Multiplying and Dividing is a lot easier. All we have to do is use the properties of exponents.

$$(5.87 \times 10^{-2})(7.45 \times 10^{-4})$$

$$(5.87 \times 7.45)(10^{-2} \times 10^{-4})$$

$$(43.7315)(10^{-6})$$

$$4.37315 \times 10^{-5}$$

*Teacher Commentary:*

*You will need to formatively assess how much practice your students may need on the procedures used to add, subtract and multiply numbers in scientific notation. Remember that the purpose of this unit is to determine and manage student misconceptions about the number system, not to focus on the procedures used in calculations. The background of your students will determine how much practice and review will be required at this point.*

## Practice Together / in Small Groups / Individually

**PRI 1**  
**PRI 2**  
**PRI 4**  
**PRI 6**  
**PRI 7**

Students work in pairs based on similar abilities to create their own scientific notation practice problems to give to other students.

INCLUDED IN THE STUDENT MANUAL

### Task #9: Scientific Notation Problems

Here are the requirements for the problems:

1. There must a scenario for each problem. Hint: Use information from the video.
2. Each group must create one problem using large numbers and one problem using small numbers.
3. Each group must have at least one problem using addition or subtraction and one problem using multiplication or division.
4. Each group must create an accurate answer key.
5. Each group will trade problems with another group (decided by the teacher) and then collect the answers from the other group.
6. Submit work to the teacher.

For students who need more practice, go to this website:

<https://janus.astro.umd.edu/astro/scinote/>

## Evaluate Understanding

Teacher will evaluate students' understanding by scoring the student-created problems and answer key based on the above criteria.

## Closing Activity

### PRI 3

Exit Slip:

How is the method for adding and subtracting numbers in scientific notation similar to the method used with decimals?

## Independent Practice:

Choosing Appropriate Units: retrieved from <https://www.illustrativemathematics.org/content-standards/tasks/1981> on 05/21/2015

INCLUDED IN THE STUDENT MANUAL

### Task #10: Choosing Appropriate Units

Retrieved from <https://www.illustrativemathematics.org/content-standards/tasks/1981> on 05/21/2015

1. A computer has 128 gigabytes of memory. One gigabyte is  $1 \times 10^9$  bytes. A floppy disk, used for storage by computers in the 1970's, holds about 80 kilobytes. There are 1000 bytes in a kilobyte. How many kilobytes of memory does a modern computer have? How many gigabytes of memory does a floppy disk have? Express your answers both as decimals and using scientific notation.
2. George told his teacher that he spent over 21,000 seconds working on his homework. Express this amount using scientific notation. What would be a more appropriate unit of time for George to use? Explain and convert to your new units.
3. A certain swimming pool contains about  $3 \times 10^7$  teaspoons of water. Choose a more appropriate unit for reporting the volume of water in this swimming pool and convert from teaspoons to your chosen units.
4. A helium atom has a diameter of about 62 picometers. There are one trillion picometers in a meter. The diameter of the sun is about 1,400,000 km. Express the diameter of a helium atom and of the sun in meters using scientific notation. About many times larger is the diameter of the sun than the diameter of a helium atom?

For students who need more practice, go to this website:  
<https://janus.astro.umd.edu/astro/scinote/>

## Resources/Instructional Materials Needed:

- The source for the planet diameters: <http://planetfacts.org/size-of-planets-in-order/>
- Task #6: Diameters of Planets
- Task #7: Size Matters: An Examination of Planets and Stars
- Task #8: Ant and Elephant
- Task #9: Scientific Notation Problems
- Task #10: Choosing Appropriate Units

## The Number System

# Lesson 8 of 11

## Formative Assessment Lesson: Estimating Length Using Scientific Notation

### Description:

---

Students will engage in the Shell Center Formative Assessment Lesson: Estimating Length Using Scientific Notation. This lesson is intended to help the teacher assess how well students attend to precision and contextualize mathematical ideas as they estimate lengths of everyday objects; convert between decimal and scientific notation; and make comparisons of the size of numbers expressed in both decimal and scientific notation. As students use appropriate tools strategically to support thinking and problem solving, they will also demonstrate flexible use of strategies and methods while reflecting on which procedures seem to work best for specific types of problems.

### College- and Career-Readiness Standards Addressed:

---

- EE.10 Use numbers expressed in the form of a single digit times an integer power of 10 to estimate very large or very small quantities, and to express how many times as much one is than the other. *For example, estimate the population of the United States as  $3 \times 10^8$  and the population of the world as  $7 \times 10^9$ , and determine that the world population is more than 20 times larger.*
- EE.11 Perform operations with numbers expressed in scientific notation, including problems where both decimal and scientific notation are used. Use scientific notation and choose units of appropriate size for measurements of very large or very small quantities (e.g., use millimeters per year for seafloor spreading). Interpret scientific notation that has been generated by technology.

### Process Readiness Indicator(s) Emphasized:

---

- PRI 1: Make sense of problems and persevere in solving through reasoning and exploration
- PRI 2: Reason abstractly and quantitatively by using multiple forms of representations to make sense of and understand mathematics.
- PRI 3: Describe and justify mathematical understandings by constructing viable arguments, critiquing the reasoning of others and engaging in meaningful mathematical discourse.
- PRI 4: Contextualize mathematical ideas by connecting them to real-world situations. Model with mathematics.
- PRI 5: Use appropriate tools strategically to support thinking and problem solving.
- PRI 6: Attend to precision.
- PRI 7: Look for and make use of patterns and structure.

- PRI 8: Look for and express regularity in repeated reasoning.
- PRI 9: Demonstrate flexible use of strategies and methods while reflecting on which procedures
- PRI 10: Reflect on mistakes and misconceptions to improve mathematical understanding.

Students will engage in the Formative Assessment Lesson: Estimating Length Using Scientific Notation, which can be found at: <http://map.mathshell.org/download.php?fileid=1664>

The following *Formative Assessment Lesson* is a classroom-ready lesson included to help teachers assess and improve students' understanding of mathematical concepts and skills and their ability to use the mathematical process readiness indicators critical for college readiness.

Research has shown that formative assessment, as embodied in the following lesson, is a powerful way to improve student learning and performance. This approach first allows students to demonstrate their prior understandings and abilities in employing the mathematical processes, and then resolve their own difficulties and misconceptions through structured discussion. This results in more secure long-term learning, reducing the need for re-teaching that otherwise takes so much classroom time.

Many often ask, why don't students just remember the procedures they have been taught and practiced? The fact is, that approach works fine in the short term but, as every teacher knows, if procedural knowledge is not underpinned by conceptual understanding, students will quickly forget "how to do it."

Read more about the *Formative Assessment Lesson* rationale, structure, and philosophy using the *Brief Guide for Teachers and Administrators* that can be found at <http://map.mathshell.org/materials/index.php>.

---

## CONCEPT DEVELOPMENT

---

Mathematics Assessment Project  
**CLASSROOM CHALLENGES**  
A Formative Assessment Lesson

# Estimating Length Using Scientific Notation

Mathematics Assessment Resource Service  
University of Nottingham & UC Berkeley

For more details, visit: <http://map.mathshell.org>  
© 2015 MARS, Shell Center, University of Nottingham  
May be reproduced, unmodified, for non-commercial purposes under the Creative Commons license  
detailed at <http://creativecommons.org/licenses/by-nc-nd/3.0/> - all other rights reserved

## BEFORE THE LESSON

### Assessment task: *Size It Up* (15 minutes)

Ask the students to complete this task, in class or for homework, a day or more before the formative assessment lesson. This will give you an opportunity to assess the work and to find out the kinds of difficulties students have with it. You will then be able to target your help more effectively in the subsequent lesson.

Give each student a copy of the task *Size It Up*.

*Read through the questions and try to answer them as carefully as you can.*

It is important that, as far as possible, students are allowed to answer the questions without your assistance.

Students should not worry if they cannot understand or do everything because in the next lesson they will work on a similar task, which should help them. Explain that by the end of the next lesson, students should be able to answer questions such as these confidently. This is their goal.

### Assessing students' responses

Collect students' responses to the task, and note down what their work reveals about their current levels of understanding and their different approaches.

We suggest that you do not score students' work. The research shows that this will be counter-productive, as it will encourage students to compare their scores and will distract their attention from what they can do to improve their mathematics.

Instead, help students to make further progress by summarizing their difficulties as a list of questions. Some suggestions for these are given in the *Common issues* table on the next page. We suggest that you make a list of your own questions, based on your students' work, using the ideas in the table. We recommend you write one or two questions on each student's work. If you do not have time to do this, you could:

- Select a few questions that will be of help to the majority of students, and write these questions on the board when you return the work to the students; or
- Give each student a printed version of your list of questions and highlight the questions for each individual student.

**Size It Up**

1. The table contains seven measurements written in decimal and scientific notation.

(a) Complete the table so that each measurement is written in both decimal and scientific notation.

(b) In the last column, rank the measurements in order of size.  
(1 = smallest, 2 = next smallest, and so on up to 7 = largest)

Decimal Notation	Scientific Notation	Rank 1 = smallest 7 = largest
	$1 \times 10^{-2}$ m	
0.004 m	=	
200 m	=	
	$8 \times 10^5$ m	
40,000,000 m	=	
40 m	=	
	$8 \times 10^{-4}$ m	

2 (a) Complete the following statement using two numbers in *decimal notation* from the table.

.....  $\times 4000 =$  .....

2 (b) Complete the following statement using two numbers in *scientific notation* from the table.

.....  $\times 50,000 =$  .....



Common issues:	Suggested questions and prompts:
<p><b>Converts measurements from scientific to decimal notation incorrectly</b> For example: The student writes <math>1 \times 10^{-2}</math> m as 0.001 m.</p>	<ul style="list-style-type: none"> <li>• What does <math>\times 10^{-1}</math> mean? What does <math>\times 10^{-2}</math> mean?</li> <li>• How can you check your answer is correct?</li> </ul>
<p><b>Does not remember the requirements for scientific notation</b> For example: The student writes 40,000,000 m as <math>40 \times 10^6</math> m.</p>	<ul style="list-style-type: none"> <li>• Have any of these numbers been written in scientific notation? <math>20 \times 10^{-2}</math>, <math>0.6 \times 10^4</math>, <math>5 \times 10^3</math></li> <li>• How do you know?</li> </ul>
<p><b>Does not fully understand the effects of negative exponents</b> For example: The student assumes that <math>8 \times 10^{-4}</math> is bigger than <math>1 \times 10^{-2}</math>.</p>	<ul style="list-style-type: none"> <li>• Is <math>10^{-4}</math> bigger than <math>10^{-2}</math>? How do you know?</li> <li>• In scientific notation, which has a bigger effect on the size of a number, the coefficient or the exponent? Explain.</li> <li>• Is <math>9 \times 10^1</math> bigger than <math>1 \times 10^2</math>? What is the difference between the two numbers?</li> <li>• Is <math>9 \times 10^{-2}</math> bigger than <math>1 \times 10^{-1}</math>? What is the difference between the two numbers?</li> </ul>
<p><b>Fails to complete the size rankings for the measurements</b></p>	<ul style="list-style-type: none"> <li>• Which measurement is the smallest? Which measurements is the biggest? How do you know?</li> </ul>
<p><b>Makes incorrect assumptions when comparing measurements</b> For example: The student assumes that question 2 cannot be completed as the coefficients in the scientific notation are limited to 1, 2, 4 and 8 and so you can't multiply any of these by either 50 or 4000 to get another listed coefficient.</p>	<ul style="list-style-type: none"> <li>• Can you use the decimal notation to help you to complete the second question?</li> <li>• Numbers in scientific notation include an integer power of ten. What effect does this have?</li> </ul>
<p><b>Completes the task</b> The student needs an extension task.</p>	<ul style="list-style-type: none"> <li>• Choose two measurements that you have not yet used in Q2. Can you work out how much bigger one measurement is than the other?</li> <li>• How much bigger is the measurement you have ranked as 2 than rank 1? Can you compare your other rankings in this way?</li> </ul>

## SUGGESTED LESSON OUTLINE

### Whole-class introduction (20 minutes)

Give each student a mini-whiteboard, pen and eraser.

Display slide P-1 of the projector resource:

A slide titled "What's the Number?" with three input boxes containing the following expressions:

$$30,000 \times 10^{-1}$$
$$3 \times 10^3$$
$$0.3 \times 10^4$$

*These three expressions all represent the same number.  
Write the number on your whiteboard [3000.]*

*Which of the expressions did you use to work out the number?  
Why did you choose this expression?*

*Did you check that the other expressions gave the same number?*

It is likely that students will use the second representation to figure out the number. Ask students to justify why all three expressions are equal.

Display slide P-2 of the projector resource, which contains the same numbers as slide 1.

*Which of these three expressions is written in scientific notation?*

Some students may assume that all three expressions are in scientific notation. Spend some time discussing student responses and address any misconceptions that arise. Students should have a clear understanding that  $3 \times 10^3$  is the only expression written using scientific notation and be able to justify why the other two representations are not scientific notation.

*A number is written in scientific notation when it is of the form  $a \times 10^n$ , where  $1 \leq a < 10$  and  $n$  is an integer.*

(Note that, when the decimal number is negative,  $-10 < a \leq -1$ , but in this lesson we focus on physical lengths, which are greater than zero.)

Display slide P-3 of the projector resource:

A slide titled "Which is Greater?" with two input boxes containing the following expressions:

$$8 \times 10^{-3}$$
$$4 \times 10^{-1}$$

*Write on your whiteboard the number you think is the greater of the two.*

If students' opinions are divided, ask students to pair up with another student with the same choice.

*In your pair, work out how much greater your chosen number is than the other number.*

Once students have had a chance to complete this calculation, choose a few pairs of students to feedback their choice and any calculations they have carried out. A common misconception is to ignore the exponent and assume that  $8 \times 10^{-3}$  is twice as big as  $4 \times 10^{-1}$  due to the fact that  $4 \times 2 = 8$ . If all students have correctly identified the greater of the two numbers, it may be appropriate to explore the different methods used to compare the two numbers and address any differences in the comparison of sizes.

**Collaborative activity: Card Set A: Measurements (15 minutes)**

Organize the class into groups of two or three students.

Give each group *Card Set A: Measurements*.

Explain how students are to work collaboratively. Slide P-4 of the projector resource summarizes these instructions.

*Take turns to match a card in decimal notation with a card in scientific notation.*

*Each time you match a pair of cards, explain your thinking clearly and carefully. Place your cards side by side on your desk, not on top of one another, so that everyone can see them.*

*Partners should either agree with the explanation, or challenge it if it is not clear, or not complete.*

*It is important that everyone in the group understands the matching of each card.*

*You should find that two cards do not have a match. Write the alternative notation for these measurements on the blank cards to produce a pair.*

If students are struggling to get started, it may be appropriate to demonstrate a correct match with the whole class. It may also be helpful for students to divide the cards into separate piles dependent on notation, before looking for matches.

As students work, you have two tasks: to note student approaches to the task and to support student reasoning.

**Note student approaches to the task**

Listen and watch students carefully. In particular, notice how students make a start on the task, where they get stuck, and how they overcome any difficulties. Do students prefer to convert from scientific to decimal notation or the other way around? How are they working out the value of the exponent? You can use this information to focus a whole-class discussion towards the end of the lesson.

**Support student reasoning**

Try not to make suggestions that move students towards a particular matching. Instead, ask questions to help students to reason together. You may want to use some of the questions in the *Common issues* table. If you find one student within the group has matched a particular pair of cards, challenge another student in the group to explain the match.

*Chen matched these two cards. Christie, why does Chen think these two cards match?*

When completing the blank measurement cards, some students may assume that for negative exponents, the magnitude of the exponent corresponds to the number of zeros after the decimal point (for example, assuming that  $1.2 \times 10^{-2} = 0.0012$  rather than 0.012.) Encourage students to explain their reasoning and use this process as a method for checking their work.

### Extending the lesson over two days

If you are taking two days to complete the unit then you may want to end the first lesson here. At the start of the second day, briefly remind students of their previous work before moving on to the next collaborative activity.

### Collaborative activity: Card Set B: Objects (15 minutes)

When students have finished matching the measurement cards, give each group *Card Set B: Objects*.

Students may already have noticed that each measurement card has an ‘m’ at the end. Ask students to suggest what this represents and clarify that all of the measurements are in meters.

For the next part of the lesson students will be matching up an everyday object from *Card Set B* with the appropriate measurement cards from *Card Set A*. It might be helpful to illustrate the rough size of a meter. Explain to students that the distance from your nose to a fingertip is about one meter.

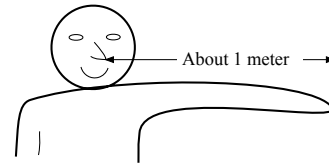

Ask students to match the objects in *Card Set B* with the corresponding paired measurements from *Card Set A*.

If students are struggling, suggest putting the object cards in order of size first and then matching them up to the measurements cards based on order of size.

As students complete all matches, ask them to check their work against that of a neighboring group.

*If there are differences between your matching, ask for an explanation. If you still don't agree, explain your own thinking.*

*You must not move the cards for another group. Instead, explain why you disagree with a particular match and explain which cards you think need to be changed.*

Slide P-5 of the projector resource summarizes these instructions.

### Collaborative activity: Card Set C: Comparisons (20 minutes)

When students are satisfied with their matches, give each group *Card Set C: Comparisons*, a glue stick, and a large sheet of paper for making a poster:

*You are now to place an arrow card between two sets of measurements/objects to show how much bigger one object is than another.*

*For example, you may choose to start with the arrow that has “ $\times 3$ ” on it. Are there two objects that have measurements such that the measurement for one of the objects multiplied by 3 gives the measurement for the other object?*

*Alternatively, you may want to start with two measurements/objects and see if there is an arrow that describes how much bigger one object is compared to the other. There are some blank arrow cards for you to use if needed.*

*Once you have linked a pair of measurements/objects, stick the cards down on your poster and see if you can compare another pair of objects. Do this for as many pairs as possible.*

Their finished poster may look something like this:

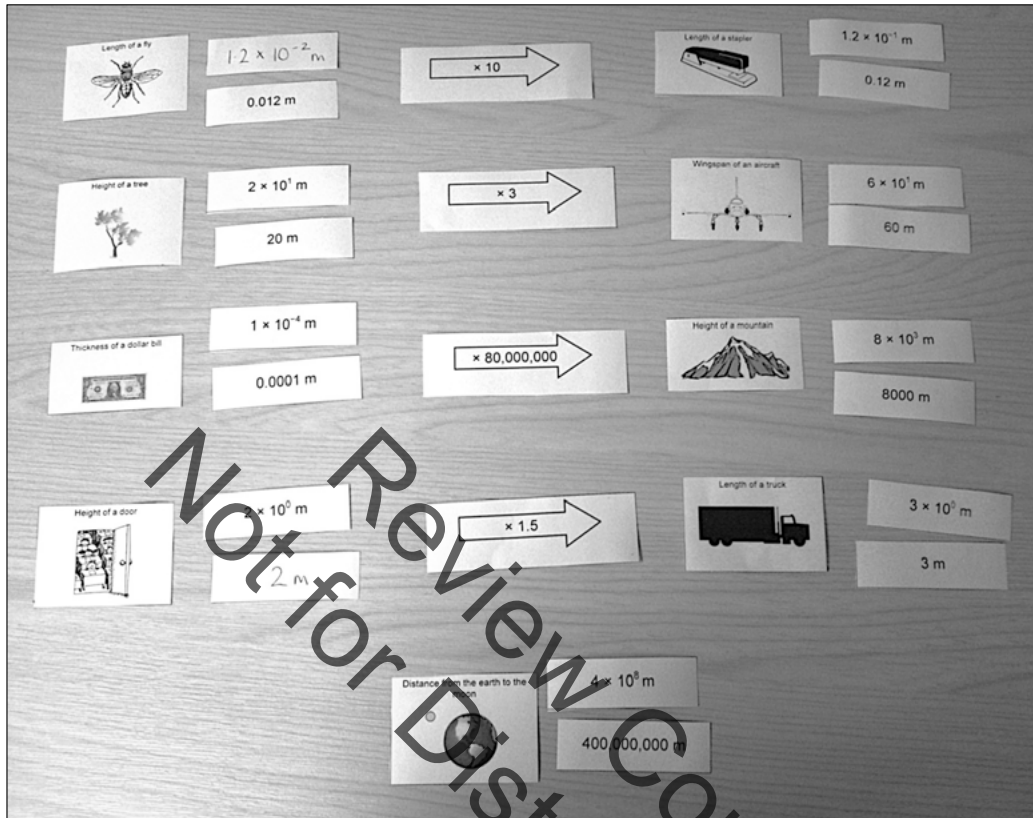

Students will be able to make a maximum of four paired comparisons with one set of object/measurement cards left over. These can be used in the extension activity if time allows. They will not need all of the arrow cards.

As students work on the task, encourage them to check their work. They may find it helpful to think about the matched objects to check whether or not their comparison is realistic, before carrying out any calculations:

*Roughly how many times bigger is the height of a tree than the height of a door? Is this a realistic comparison? Can you now check it mathematically?*

Students should be encouraged to justify the comparisons made and describe their methods:

*Can you explain why you placed this arrow here?*

*In this task, do you find it easier to use the decimal notation card or the scientific notation card? Why?*

When students have completed as many comparisons as possible and stuck them down, ask them to stick down any remaining matched up object/measurement cards on their poster as well.

### Extension activity

If a group successfully completes four comparisons, ask them to compare their remaining object with an object of their own choice. They need to decide on an object and its measurement and state how many times bigger it is. They can either select one of the unused arrow cards or write their own.

**Whole-class discussion (10 minutes)**

Organize a discussion about what has been learned and encourage students to explore the different methods used. It is likely that each poster will be slightly different, depending on the comparisons made.

*Michael, explain how you matched one arrow card with two measurement/object cards.*

*Did anyone else complete the same comparison?*

In addition to asking for a variety of methods, pursue the theme of listening and comprehending others' methods by asking students to rephrase others' reasoning.

*Can someone else put that into your own words?*

*Does anyone disagree with this comparison?*

There will not be time to discuss all the comparisons, but a good coverage of measurements should be encouraged.

**Follow-up lesson: Reviewing the assessment task (15 minutes)**

Give each student a copy of the review task, *Resize It Up!*, and their original scripts from the assessment task, *Size It Up*. If you have not added questions to individual pieces of work, then write your list of questions on the board. Students should select from this list only those questions they think are appropriate to their own work.

*Read through your scripts from Size It Up, and the questions [on the board/written on your script.]*

*Use what you have learned to answer these questions.*

*Now look at the new task sheet, Resize It Up! Can you use what you have learned to answer these questions?*

**SOLUTIONS**

**Assessment Task: Size It Up**

1.

Decimal Notation	Scientific Notation	Rank order
0.01 m	$1 \times 10^{-2} m$	3
0.004 m	$4 \times 10^{-3} m$	2
200 m	$2 \times 10^2 m$	5
800,000 m	$8 \times 10^5 m$	6
40,000,000 m	$4 \times 10^7 m$	7
40 m	$4 \times 10^1 m$	4
0.0008 m	$8 \times 10^{-4} m$	1

2 (a) There are two alternatives:

$$0.01 \text{ m} \quad \times 4000 \quad = \quad 40 \text{ m}$$

$$200 \text{ m} \quad \times 4000 \quad = \quad 800,000 \text{ m}$$

2 (b) There are two alternatives:

$$8 \times 10^{-4} \text{ m} \quad \times 50,000 \quad = \quad 4 \times 10^1 \text{ m}$$

$$4 \times 10^{-3} \text{ m} \quad \times 50,000 \quad = \quad 2 \times 10^2 \text{ m}$$

**Assessment Task: *Resize It Up!***

1.

Decimal Notation	Scientific Notation	Rank order
6 m	$6 \times 10^0 m$	4
120,000 m	$1.2 \times 10^5 m$	7
0.0012 m	$1.2 \times 10^{-3} m$	2
300 m	$3 \times 10^2 m$	5
0.6 m	$6 \times 10^{-1} m$	3
0.0009 m	$9 \times 10^{-4} m$	1
6,000 m	$6 \times 10^3 m$	6

2 (a) There are two alternatives:

$$300 \text{ m} \quad \times 20 \quad = \quad 6,000 \text{ m}$$

$$6,000 \text{ m} \quad \times 20 \quad = \quad 120,000 \text{ m}$$

2 (b) There are two alternatives:

$$6 \times 10^{-1} \text{ m} \quad \times 500 \quad = \quad 3 \times 10^2 \text{ m}$$

$$1.2 \times 10^{-3} \text{ m} \quad \times 500 \quad = \quad 6 \times 10^{-1} \text{ m}$$



**Collaborative activity**

The measurements in **bold** correspond to blank cards.

Scientific Notation	Decimal Notation	Object
$1 \times 10^{-4}$ m	0.0001 m	Thickness of a dollar bill
<b><math>1.2 \times 10^{-2}</math> m</b>	0.012 m	Length of a fly
$1.2 \times 10^{-1}$ m	0.12 m	Length of a stapler
$2 \times 10^0$ m	<b>2 m</b>	Height of a door
$3 \times 10^0$ m	3 m	Length of a truck
$2 \times 10^1$ m	20 m	Height of a tree
$6 \times 10^1$ m	60 m	Wingspan of an aircraft
$8 \times 10^3$ m	8000 m	Height of a mountain
$4 \times 10^8$ m	400,000,000 m	Distance from the earth to the moon

There are numerous comparisons that can be made. For example:

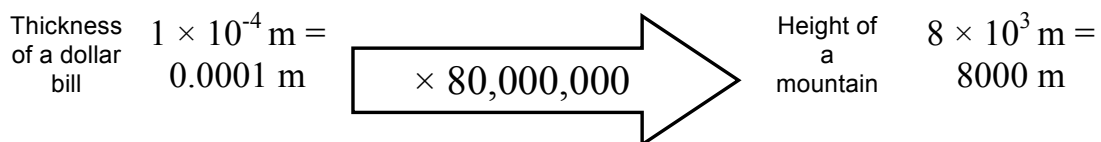
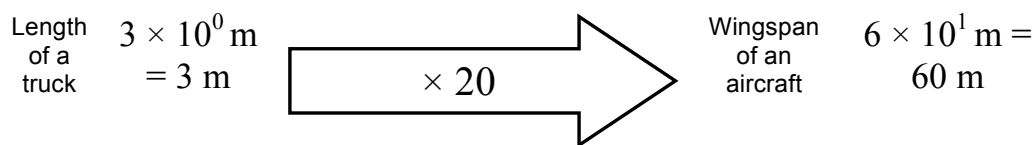

Some of the arrows will be redundant depending on the comparisons made.

## Size It Up

1. The table contains seven measurements written in decimal and scientific notation.
- (a) Complete the table so that each measurement is written in *both* decimal *and* scientific notation.
- (b) In the last column, rank the measurements in order of size.  
(1 = smallest, 2 = next smallest, and so on up to 7 = largest)

Decimal Notation	Scientific Notation	Rank 1 = smallest 7 = largest
	$1 \times 10^{-2} \text{ m}$	
0.004 m		
200 m		
	$8 \times 10^5 \text{ m}$	
40,000,000 m		
40 m		
	$8 \times 10^{-4} \text{ m}$	

- 2 (a) Complete the following statement using two numbers in *decimal notation* from the table.

$$\underline{\hspace{2cm}} \times 4000 = \underline{\hspace{2cm}}$$

- 2 (b) Complete the following statement using two numbers in *scientific notation* from the table.

$$\underline{\hspace{2cm}} \times 50,000 = \underline{\hspace{2cm}}$$

### Card Set A: Measurements









#### Decimal notation

20 m	60 m	0.012 m
0.12 m	3 m	8000 m
400,000,000 m	0.0001 m	

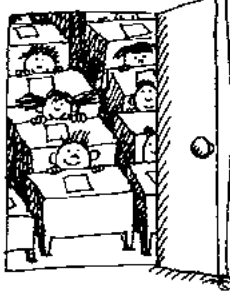
#### Scientific notation

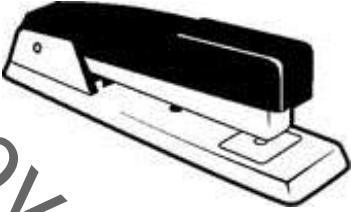
$2 \times 10^0$ m	$1 \times 10^{-4}$ m	$8 \times 10^3$ m
$3 \times 10^0$ m	$2 \times 10^1$ m	$4 \times 10^8$ m
$6 \times 10^1$ m	$1.2 \times 10^{-1}$ m	

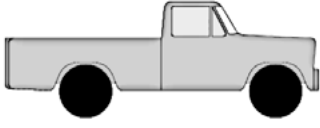
### Card Set B: Objects

<p>Height of a tree</p> 	<p>Distance from the earth to the moon</p> 	<p>Height of a door</p> 
<p>Height of a mountain</p> 	<p>Thickness of a dollar bill</p> 	<p>Length of a stapler</p> 
<p>Length of a fly</p> 	<p>Length of a truck</p> 	<p>Wingspan of an aircraft</p> 

### Card Set C: Comparisons

$\times 1200$	$\times 1.5$
$\times 20,000$	$\times 10$
$\times 20$	$\times 400$
$\times 3$	$\times 80,000,000$
$\times 4000$	$\times 120$
$\times 30$	$\times 30,000$

## Resize It Up!

1. The table contains seven measurements written in decimal and scientific notation.
- (a) Complete the table so that each measurement is written in *both* decimal *and* scientific notation.
- (b) In the last column, rank the measurements in order of size.  
(1 = smallest, 2 = next smallest, and so on up to 7 = largest)

Decimal Notation	Scientific Notation	Rank 1 = smallest 7 = largest
	$6 \times 10^0$ m	
120,000 m		
0.0012 m		
	$3 \times 10^2$ m	
0.6 m		
	$9 \times 10^{-4}$ m	
6000 m		

- 2 (a) Complete the following statement using two numbers in *decimal notation* from the table.

$$\text{.....} \times 20 = \text{.....}$$

- 2 (b) Complete the following statement using two numbers in *scientific notation* from the table.

$$\text{.....} \times 500 = \text{.....}$$

## What's the Number?

$$30,000 \times 10^{-1}$$

$$3 \times 10^3$$

$$0.3 \times 10^4$$

## Scientific Notation or Not?

$$30,000 \times 10^{-1}$$

$$3 \times 10^3$$

$$0.3 \times 10^4$$



## Which is Greater?

$$8 \times 10^{-3}$$

$$4 \times 10^{-1}$$

Not for Review Copy  
Distribution

## Matching Card Set A

1. Take turns to match a card in scientific notation with a card in decimal notation.
2. Each time you match a pair of cards explain your thinking clearly and carefully. Place your cards side by side on your desk, not on top of one another, so that everyone can see them.
3. Partners should either agree with the explanation, or challenge it if it is not clear or not complete.
4. It is important that everyone in the group understands the matching of each card.
5. You should find that two cards do not have a match. Write the alternative notation for these measurements on the blank cards to produce a pair.

## Matching Card Set B

1. Match the objects in *Card Set B* with the corresponding paired measurements from *Card Set A*. You may want to put the objects in size order first to help you.
2. It is important that everyone in the group agrees on each match.
3. When you have finished matching the cards, check your work against that of a neighboring group.
4. If there are differences between your matching, ask for an explanation. If you still don't agree, explain your own thinking.
5. You must not move the cards for another group. Instead, explain why you disagree with a particular match and explain which cards you think need to be changed.

## Mathematics Assessment Project **Classroom Challenges**

These materials were designed and developed by the  
Shell Center Team at the Center for Research in Mathematical Education  
University of Nottingham, England:

**Malcolm Swan,**  
**Nichola Clarke, Clare Dawson, Sheila Evans, Colin Foster, and Marie Joubert**  
with  
**Hugh Burkhardt, Rita Crust, Andy Noyes, and Daniel Pead**

We are grateful to the many teachers and students, in the UK and the US,  
who took part in the classroom trials that played a critical role in developing these materials

The classroom observation teams in the US were led by  
**David Foster, Mary Bouck, and Diane Schaefer**

This project was conceived and directed for  
The Mathematics Assessment Resource Service (MARS) by  
**Alan Schoenfeld** at the University of California, Berkeley, and  
**Hugh Burkhardt, Daniel Pead, and Malcolm Swan** at the University of Nottingham

Thanks also to Mat Crosier, Anne Floyde, Michael Galan, Judith Mills, Nick Orchard, and Alvaro Villanueva who contributed to the design and production of these materials

This development would not have been possible without the support of  
**Bill & Melinda Gates Foundation**

We are particularly grateful to  
**Carina Wong, Melissa Chabran, and Jamie McKee**

The full collection of Mathematics Assessment Project materials is available from

<http://map.mathshell.org>

© 2015 MARS, Shell Center, University of Nottingham  
This material may be reproduced and distributed, without modification, for non-commercial purposes,  
under the Creative Commons License detailed at <http://creativecommons.org/licenses/by-nc-nd/3.0/>  
All other rights reserved.  
Please contact [map.info@mathshell.org](mailto:map.info@mathshell.org) if this license does not meet your needs.

## The Number System

# Lesson 9 of 11

## Addressing Misconceptions about Scientific Notation

### Description:

---

Students will be grouped based on misconceptions noted on the post-lesson assessment for the Formative Assessment Lesson: Estimating Length Using Scientific Notation so that they can reflect on mistakes and misconceptions to improve their mathematical understandings and make sense of problems while persevering in solving. They will also reason abstractly and quantitatively.

### College- and Career-Readiness Standards Addressed:

---

- 8.EE.10 Use numbers expressed in the form of a single digit times an integer power of 10 to estimate very large or very small quantities, and to express how many times as much one is than the other. *For example, estimate the population of the United States as  $3 \times 10^8$  and the population of the world as  $7 \times 10^9$ , and determine that the world population is more than 20 times larger.*
- 8.EE.11 Perform operations with numbers expressed in scientific notation, including problems where both decimal and scientific notation are used. Use scientific notation and choose units of appropriate size for measurements of very large or very small quantities (e.g., use millimeters per year for seafloor spreading). Interpret scientific notation that has been generated by technology.

### Process Readiness Indicator(s) Emphasized:

---

- PRI 1: Make sense of problems and persevere in solving through reasoning and exploration
- PRI 2: Reason abstractly and quantitatively by using multiple forms of representations to make sense of and understand mathematics.
- PRI 3: Describe and justify mathematical understandings by constructing viable arguments, critiquing the reasoning of others and engaging in meaningful mathematical discourse.
- PRI 7: Look for and make use of patterns and structure.

Sequence of  
Instruction

Activities Checklist

## Engage

Group students based on misconceptions noted on the post-lesson assessment from the Formative Assessment Lesson: Estimating Length using Scientific Notation. If possible, students should be grouped with students that they did not work with during the FAL.

Explain to students they are grouped purposefully and each group will participate in a specific lesson designed to reduce misconceptions and deepen their understanding.

## Explore

PRI 1  
PRI 2  
PRI 7

### Group #1

*Misconception: Students convert from scientific notation to decimal form incorrectly.*

Instruct Students to visit the following web sites and do the Scientific Notation Intuition and the Scientific Notation Practice Problems.

<https://www.khanacademy.org/math/pre-algebra/pre-algebra-exponents-radicals/pre-algebra-scientific-notation/e/scientific-notation>

Students should complete this activity on their own or in small groups.

### Group #2

*Misconception: Students do not understand the effects of negative exponents.*

Group students in pairs based on similar abilities. Give pairs of students a number line that is broken into sections labeled as 0, 0.1, 0.01, 0.001, 0.0001, 0.00001, ...

Give students cards that contain numbers written in scientific notation with only negative exponents. Students must convert the scientific notation to decimal form and then place the cards on the number line. Students should write mathematical rules about negative exponents in scientific notation based on what they learned from looking at the completed number line.

Students should complete a gallery walk of the other groups that completed the same task. They should make notes on the other groups' results and math rules. All notes should be in the form of a question.

### Group #3

*Extension: This is for students that showed no weaknesses during the FAL the previous lesson. Students will use this time to create their own card sets for use in unit review or remediation.*

Instruct students to create four card sets.

- Card Set # 1: Students should make a list of objects (small and large) they want to use and choose a piece of clipart to go with it. This information will go on the first set of cards. They should research the exact size of the objects they have chosen.
- Card Set #2: The measurements written in decimal form should be written on the second card set.

- Card Set #3: The scientific notation form of the measurements should be written on the third card set.
- Card Set #4: The students should figure out what the multipliers would be to go from one card set to the others and put them on the fourth card set.

## Explanation

---

As you circulate to each group (Group #1, Group #2, and Group #3), facilitate whole-group discussions about what processes students have used to complete their tasks as well as what students have learned.

**PRI 3**

## Practice Together / in Small Groups / Individually

---

### Groups #1 and #2

Group students in pairs based on similar abilities (one student from Group 1 and one student from Group 2). Each group will make two sets of cards on different color paper. On one color write numbers in scientific notation. Be sure to include numbers that have both positive and negative exponents. On the other color make cards that have the decimal equivalents written on them.

**PRI 1**  
**PRI 2**  
**PRI 7**

Each pair of students will swap their card sets with another pair and work through them to check for errors.

### Group #3:

Students swap their card sets with another group and work through them to check for errors.

## Evaluate Understanding

---

Each group will have 3 minutes to report out to then whole class about what they worked on during the class and what they learned from their lesson. Examples should be used in their presentation.

**PRI 3**

## Closing Activity

---

Exit Slip:

Each student must take a slip of paper and create and write a number in scientific notation form with a positive exponent and a number in scientific notation form with a negative exponent. They must convert each to decimal form.

## Resources/Instructional Materials Needed:

---

- Internet access
- Computer, laptop, or tablet
- Printer
- Colored paper
- Glue or tape
- Poster board or chart paper

## The Number System

# Lesson 10 of 11

## Rational and Irrational Numbers

### Description:

---

Students will demonstrate flexible use of strategies and methods while reflecting on which procedures seem to work best as they compare and contrast the properties of rational and irrational numbers. Throughout the lesson, they will reflect on mistakes and misconceptions and look for and make use of patterns, structure and repeated reasoning.

### College- and Career-Readiness Standards Addressed:

---

- NS.4 Know that numbers that are not rational are called irrational. Understand informally that every number has a decimal expansion; for rational numbers show that the decimal expansion repeats eventually, and convert a decimal expansion which repeats eventually into a rational number.
- NS.5 Use rational approximations of irrational numbers to compare the size of irrational numbers, locate them approximately on a number line diagram, and estimate the value of expressions (e.g.,  $\pi^2$ ). *For example, by truncating the decimal expansion of  $\sqrt{2}$ , show that  $\sqrt{2}$  is between 1 and 2, then between 1.4 and 1.5, and explain how to continue on to get better approximations.*

### Process Readiness Indicator(s) Emphasized:

---

- PRI 2: Reason abstractly and quantitatively by using multiple forms of representations to make sense of and understand mathematics.
- PRI 3: Describe and justify mathematical understandings by constructing viable arguments, critiquing the reasoning of others and engaging in meaningful mathematical discourse.
- PRI 5: Use appropriate tools strategically to support thinking and problem solving.
- PRI 7: Look for and make use of patterns and structure.
- PRI 8: Look for and express regularity in repeated reasoning.
- PRI 10: Reflect on mistakes and misconceptions to improve mathematical understanding.



Sequence of  
Instruction

Activities Checklist

## Engage

- PRI 2** Students are provided with a number on a large card or piece of paper. The numbers are various types of rational and irrational numbers in various forms (sample numbers can be found in the notes section at the end of this lesson). Place four to six posters around the room labeled as follows: Rational, Irrational, Whole, Natural, Integers. Students stand near the poster they believe is the proper classification for their numbers.

## Explore

- PRI 2** *Teacher's Note: Students may have a common misconception that every radical is irrational and that decimals extending beyond the tenths place are irrational.*
- PRI 3**
- PRI 8**
- PRI 10** Ask students to record their numbers on the poster they are standing near. Encourage conversation and debate between group members and also between groups as to appropriate placement. Students may realize that their numbers can be a part of more than one group. After 3-5 minutes, ask students to move to another group/poster and encourage the same debate. Pose questions such as "Why do you belong in this group? How can you justify being a part of more than one group?" Students should then record their number on the poster if he/she believes it belongs there. Repeat steps one or two more times.

## Explanation

- PRI 2**
- PRI 3**
- PRI 5**  
(if allowed  
calculators)
- PRI 7**
- PRI 8** Facilitate a whole-group discussion about each poster. Review a few ratios and ask students to demonstrate converting fractions to terminating decimals. Compare and contrast in a think/share on numbers that do not terminate. Students should generate several more irrational numbers and prepare a justification as to why they are not rational — in written form. Choose several for presentation.

## Practice Together / in Small Groups / Individually

- PRI 2**
- PRI 3**
- PRI 7** Students should generate several more irrational numbers and prepare a justification as to why they are not rational - in written form.

## Evaluate Understanding

- PRI 2**
- PRI 3**
- PRI 7**
- PRI 8** Students now write their generated rational and irrational numbers on a sheet of paper and arrange themselves in order from least to greatest across the front or back of room. Two to four student checkers must walk up and down the line to determine accuracy. Facilitator asks questions of students standing in order such as: How do you know you are less than \_\_\_\_ (the person next to you)? Can you justify that you are greater than \_\_\_\_ (another person on line)?

Select five numbers students have created and write them on the board. Ask students to write them in order from least to greatest on their mini-whiteboards. This serves as quick formative assessment of student understanding.

## Closing Activity

Exit Slip:

Complete the following statements.

1. I know a number is irrational when...
2. I know a number is rational when...

## Independent Practice:

[http://www.online.math.uh.edu/MiddleSchool/Modules/Module\\_3\\_Measurement/Content/IrrationalNumbers.pdf](http://www.online.math.uh.edu/MiddleSchool/Modules/Module_3_Measurement/Content/IrrationalNumbers.pdf)

*Teacher's note: This assignment is traditional in nature and can be used in chunks for students who need direct instruction or remediation in a particular area. The independent practice was chosen as a resource for teachers to personalize assistance for students. It should NOT be assigned as a whole for independent practice.*

## Resources/Instructional Materials Needed:

- Masters of numbers (35) including rational, irrational, natural, integer, whole numbers
- 4-6 pieces of large poster paper or areas that can be written on
- Markers, crayons or sticky notes to record numbers

## Notes:

Numbers for handing out to students:

10	$\frac{2}{3}$	0.454455444555
4.35	$\frac{1}{8}$	$\frac{21}{55}$
-10	10%	$\frac{5}{4}$
$-\frac{4}{2}$	15	$\frac{25}{9}$
0.33333333	6	$\frac{5}{8}$
0.30	0.31311311131111	$\frac{1}{4}$
$\pi$	7.15151515	19.5%
$\sqrt{10}$	0.001	$\frac{1}{4}$
$\sqrt{9}$	$\frac{1}{100}$	-0.0052
$\sqrt{2}$	100	150
$\sqrt{1}$	$\frac{253}{10}$	$\sqrt{15}$
$\frac{3}{2}$	2.9	0.2492109532
0		

## The Number System

# Lesson 11 of 11

## Return to the Entry Event: Examining the Number System

### Description:

---

Students will return to the entry event and make sense of problems involving various forms such as fractions, decimals, percents, scientific notation and irrational numbers while reasoning. Students will reason abstractly and quantitatively by using multiple representations as they compare and order numbers in various forms such as fractions, decimals, percents, scientific notation and irrational numbers. Students will reflect on mistakes and misconceptions to improve their mathematical understanding from first lesson as they match equivalent forms of numbers.

### College- and Career-Readiness Standards Addressed:

---

- NS.2 Apply and extend previous understandings of addition and subtraction to add and subtract rational numbers; represent addition and subtraction on a horizontal or vertical number line diagram.
- NS.3. Apply and extend previous understandings of multiplication and division and of fractions to multiply and divide rational numbers.
- NS.4 Know that numbers that are not rational are called irrational. Understand informally that every number has a decimal expansion; for rational numbers show that the decimal expansion repeats eventually, and convert a decimal expansion which repeats eventually into a rational number.
- NS.5 Use rational approximations of irrational numbers to compare the size of irrational numbers, locate them approximately on a number line diagram, and estimate the value of expressions (e.g.,  $\pi^2$ ). *For example, by truncating the decimal expansion of  $\sqrt{2}$ , show that  $\sqrt{2}$  is between 1 and 2, then between 1.4 and 1.5, and explain how to continue on to get better approximations.*
- EE.10 Use numbers expressed in the form of a single digit times an integer power of 10 to estimate very large or very small quantities, and to express how many times as much one is than the other. *For example, estimate the population of the United States as  $3 \times 10^8$  and the population of the world as  $7 \times 10^9$ , and determine that the world population is more than 20 times larger.*

### Process Readiness Indicator(s) Emphasized:

---

- PRI 2: Reason abstractly and quantitatively by using multiple forms of representations to make sense of and understand mathematics.
- PRI 3: Describe and justify mathematical understandings by constructing viable arguments, critiquing the reasoning of others and engaging in meaningful mathematical discourse.

- PRI 5: Use appropriate tools strategically to support thinking and problem solving.
- PRI 7: Look for and make use of patterns and structure.
- PRI 8: Look for and express regularity in repeated reasoning.
- PRI 10: Reflect on mistakes and misconceptions to improve mathematical understanding.

Sequence of Instruction

Activities Checklist

Engage

PRI 1  
PRI 2  
PRI 3

*Teacher's Note: Reuse or once again print and cut the cards from the lesson 1 entry event. These cards will be used again in this lesson.*

This activity is an extension of the Entry Event from Lesson 1. The students should now be able to compare more numbers than they could in Lesson 1. Encourage students to discuss their methods for comparing numbers and how it has changed since the last time they completed this activity.

Provide students with three to five cards upon entry to classroom setting. The cards will be in various forms – decimals, fractions, percents, scientific notation, radicals, and other irrational numbers. With a partner or alone, students should order the cards from least to greatest at their desks.

*Teacher's Note: Each student will receive a unique set of numbers.*

Circulate the classroom, and ask questions that will encourage students to justify the placement of the cards. Allow students to work for 5-7 minutes.

Explore

PRI 1  
PRI 2  
PRI 3

*Teacher Notes: Students often have difficulty distinguishing between various representations of rational and irrational numbers. Students also do not commonly understand that scientific notation is a way to represent a very small or very large number. Knowing equivalency for irrational and uncommon rational numbers can also present a challenge.*

*Prior to enacting this lesson with students, create a number line in integer format from -30 to 30 using several pieces of chart paper or butcher paper. The number line needs to be large enough for students to place their numbers on it.*

Divide the class into groups of 2-4 students. Ask each group to work together to order their cards on the class number line.

Allow students 10-20 minutes depending on whether calculators are provided (teacher choice).

As students are working, formatively assess their understanding. Listen to what students say as they explain their reasoning to their partner. Encourage students to discuss the difference between terminating and repeating decimals, and rational and irrational numbers.

If the majority of the class is struggling with the placement of cards, allow 4-6 students to share one card they are struggling to place. Ask questions such as the following:

- Has anyone placed Susan's card? How did you decide where it should go on the number line?
- Jason placed this card between \_\_\_ and \_\_\_. Why do you think he decided this was the right place for this card?
- Does someone have an irrational number he can place between 0 and 10? How do you know this is the right place for this card?
- Does someone else have a number in scientific notation between 0 and 1? How do you know this is the right place for this card?

Ask students to compare and contrast in a think/share on numbers that do not terminate.

## Explanation

---

### PRI 3

Ask students to provide written justifications on written response form for the smallest, largest and median numbers; the second smallest, second largest, the third smallest, third largest and fourth smallest, fourth largest.

*Teacher's Note: The written portion can be differentiated by asking students to identify two numbers closest to zero, the number farthest from zero, etc.*

## Practice Together / in Small Groups / Individually

---

### PRI 3

Using colored stickers for each set of identified numbers, ask students to label each identified number by placing the appropriate color sticker on the card. For example, red labels represent the largest, smallest and median numbers. Yellow stickers identify the second smallest, second largest, etc.

*Teacher's Note: If stickers are not available, students can label the identified numbers using specific color markers.*

## Evaluate Understanding

---

### PRI 3

### PRI 10

Groups either agree or disagree with other group's findings and report out what changes, if any should be made.

Collect the written response form and assess whether students understand the placement of certain numbers on the number line.

## Closing Activity

---

### PRI 3

### PRI 10

Students reflect on the growth they have had in this unit in a written assignment. Students should answer the following questions:

1. Explain how you determined the order of the cards.
2. How is your method better than the one you used at the beginning of this unit?
3. Give at least three examples to show that you now know more about numbers than you did before this unit.

### Resources/Instructional Materials Needed:

---

- Cards – 100 different numbers of decimals, fractions, %, scientific notation, radicals, irrationals
- Number line (-30 to 30)
- Written response form
- Colored stickers or markers
- Chart paper or butcher paper

Review Copy  
Not for Distribution

# SREB

## SREB Readiness Courses

# Ready for High School: Math

### Math Unit 2

### Ratio and Proportional Relationships

Not for Review Copy Distribution



Southern  
Regional  
Education  
Board

592 Tenth Street, NW  
Atlanta, GA 30318  
(404) 875-9211

[www.sreb.org](http://www.sreb.org)

## Unit 2 . Ratio and Proportional Relationships

### Overview

This unit was designed to solidify students' understanding of ratios and develop understanding of proportionality to solve single- and multi-step problems.

### Essential Questions:

---

- *How is a ratio or rate used to compare two quantities or values?*
- *How can I model and represent rates, ratios and proportions?*
- *How can I use proportions to determine if two figures are similar and solve for missing sides of similar figures?*
- *How can I use equations to represent proportional situations?*
- *Where is the constant of proportionality seen in a graph?*
- *How is a unit rate related to the slope of a line?*
- *How do scale drawings assist in problem solving?*



## College- and Career-Readiness Standards:

---

- RP.1 Understand the concept of a ratio and use ratio language to describe a ratio relationship between two quantities.
- RP.2 Understand the concept of a unit rate  $a/b$  associated with a ratio  $a:b$  with  $b \neq 0$ , and use rate language in the context of a ratio relationship.
- RP.3 Use ratio and rate reasoning to solve real-world and mathematical problems.
- RP.4 Compute unit rates associated with ratios of fractions, including ratios of lengths, areas and other quantities measured in like or different units.
- RP.5 Recognize and represent proportional relationships between quantities.
  - a. Decide whether two quantities are in a proportional relationship, e.g., by testing for equivalent ratios in a table or graphing on a coordinate plane and observing whether the graph is a straight line through the origin.
  - b. Identify the constant of proportionality (unit rate) in tables, graphs, equations, diagrams, and verbal descriptions of proportional relationships.
  - c. Represent proportional relationships by equations. For example, if total cost  $t$  is proportional to the number  $n$  of items purchased at a constant price  $p$ , the relationship between the total cost and the number of items can be expressed as  $t = pn$ .
  - d. Explain what a point  $(x, y)$  on the graph of a proportional relationship means in terms of the situation, with special attention to the points  $(0, 0)$  and  $(1, r)$  where  $r$  is the unit rate.
- RP.6 Use proportional relationships to solve multi-step ratio and percent problems.
- G.1 Solve problems involving scale drawings of geometric figures, including computing actual lengths and areas from a scale drawing and reproducing a scale drawing at a different scale.
- EE.12 Graph proportional relationships, interpreting the unit rate as the slope of the graph. Compare two different proportional relationships represented in different ways. For example, compare a distance-time graph to a distance-time equation to determine which of two moving objects has greater speed.
- EE.13 Use similar triangles to explain why the slope  $m$  is the same between any two distinct points on a non-vertical line in the coordinate plane; derive the equation  $y = mx$  for a line through the origin and the equation  $y = mx + b$  for a line intercepting the vertical axis at  $b$ .

## Prior Scaffolding Knowledge / Skills:

---

- Understand the concept of a ratio and use ratio language to describe a ratio relationship between two quantities.
- Understand the concept of a unit rate  $a/b$  associated with a ratio  $a : b$  with  $b$  not equal to 0, and use rate language in the context of a ratio relationship.
- Use ratio and rate reasoning to solve real-world and mathematical problems, e.g., by reasoning about tables of equivalent ratios, tape diagrams, double number line diagrams, or equations.

### Lesson Progression Overview:

Lesson Big Idea	Lesson Details	Content Standards	Process Readiness Indicators
<b>Lesson 1: Entry Event: Ratios and Proportions</b>	Students will be introduced to this unit using an interactive lesson requiring them to apply their knowledge of ratios, unit rates, and proportions to sort through the clues and deduce which suspect robbed the National Bank of Illuminations.	RP.1 RP.2 RP.4 RP.6	PRI 1 PRI 2 PRI 3 PRI 4 PRI 6 PRI 9 PRI 10
<b>Lesson 2: Ratios</b>	In this lesson students will learn what a ratio is and how it can be used in comparison. Students will also determine how to combine a sports drink in powder form and water to make enough for a whole football team. Students will be encouraged to use different strategies such as ratios and proportions.	RP.1 RP.2 RP.3 RP.4	PRI 2 PRI 3 PRI 4 PRI 7
<b>Lesson 3: Unit Rate</b>	Students will extend their understanding of ratios and solve unit rate problems including those involving constant speed. Students will use rate and unit rate to determine if a relationship is proportional.	RP.3 RP.5	PRI 1 PRI 3 PRI 4 PRI 6 PRI 7
<b>Lesson 4: Proportional Reasoning</b>	Students will develop proportional reasoning skills by comparing quantities, looking at the relative ways numbers change, and thinking about proportional relationships in linear functions.	RP.5	PRI 1 PRI 3 PRI 4
<b>Lesson 5: Formative Assessment Lesson: Classifying Proportion and Non-Proportion Situations</b>	This lesson will assess whether students are able to identify when two quantities vary in direct proportion to each other; distinguish between direct proportion and other functional relationships; and solve proportionality problems using efficient methods.	RP	PRI 1 PRI 2 PRI 3 PRI 5 PRI 6 PRI 7 PRI 8 PRI 9 PRI 10
<b>Lesson 6: Proportions</b>	In this lesson, students will work with relationships in which two quantities vary together. They will understand the multiplicative nature of proportional reasoning and develop a wide variety of strategies for solving proportion and ratio problems.	RP.5	PRI 1 PRI 2 PRI 7 PRI 7 PRI 8 PRI 9 PRI 10
<b>Lesson 7: Identifying Similar Figures Using Proportionality</b>	In this lesson, students will learn about similar figures, corresponding sides and scale factors.	RP.5	PRI 1 PRI 2 PRI 3 PRI 7 PRI 8

Lesson Big Idea	Lesson Details	Content Standards	Process Readiness Indicators
<b>Lesson 8: Slope Part 1</b>	Students will examine slope and y-intercept within the context of a real-world problem. They will write and graph a linear equation given two points on a line and discuss what it means for a function to be linear. In this lesson, students will graph proportional relationships and interpret the unit rate as the slope of the line. Students will construct a function to model a linear relationship between two quantities. Students will also explore similar triangles and use them to explain why the slope is constant between any two points on a given line.	EE.12 EE.13	PRI1 PRI2 PRI3 PRI4 PRI5
<b>Lesson 9: Slope Part 2 (optional)</b>	Students will examine slope and y intercept within the context of a real world problem. They will write and graph a linear equation given two points on a line and discuss what it means for a function to be linear.	EE.12 EE.13	PRI5 PRI7 PRI8
<b>Lesson 10: Scaling</b>	This lesson will explore scale models and scale drawings. Scale factors are discussed. Students will solve problems involving scale drawings of geometric figures, including computing actual lengths and areas from a scale drawing and reproducing a scale drawing at a different scale.	G.1 EE.12	PRI 1 PRI 6 PRI 10
<b>Lesson 11: Formative Assessment Lesson: Drawing to Scale: Designing a Garden</b>	This lesson is intended to help assess how well students are able to interpret and use scale drawings to plan a garden layout. This involves using proportional reasoning and metric units.	RP G EE	PRI 1 PRI 2 PRI 3 PRI 4 PRI 5 PRI 6 PRI 8 PRI 9 PRI 10
<b>Lesson 12: Ratios and Proportions Revisited</b>	Students will return to the entry event interactive lesson requiring them to apply their knowledge of ratios, unit rates, and proportions to sort through the clues and deduce which suspect robbed the National Bank of Illuminations.	RP.1 RP.2 RP.4 RP.6	PRI 1 PRI 2 PRI 3 PRI 4 PRI 6 PRI 9 PRI 10

## Ratio and Proportional Relationships

# Lesson 1 of 12

## Entry Event: Ratios and Proportions

### Description:

---

Students will be introduced to this unit using an interactive lesson requiring them to apply their knowledge of ratios, unit rates, and proportions to sort through the clues and deduce which suspect robbed the National Bank of Illuminations.

### College- and Career-Readiness Standards Addressed:

---

- RP.1 Understand the concept of a ratio and use ratio language to describe a ratio relationship between two quantities.
- RP.2 Understand the concept of a unit rate  $a/b$  associated with a ratio  $a:b$  with  $b \neq 0$ , and use rate language in the context of a ratio relationship.
- RP.4 Compute unit rates associated with ratios of fractions, including ratios of lengths, areas and other quantities measured in like or different units.
- RP.6 Use proportional relationships to solve multi-step ratio and percent problems.

### Process Readiness Indicator(s) Emphasized:

---

- PRI 1: Make sense of problems and persevere in solving through reasoning and exploration.
- PRI 2: Reason abstractly and quantitatively by using multiple forms of representations to make sense of and understand mathematics.
- PRI 3: Describe and justify mathematical understandings by constructing viable arguments, critiquing the reasoning of other and engaging in meaningful mathematical discourse.
- PRI 4: Contextualize mathematical ideas by connecting them to real-world situations. Model with mathematics.
- PRI 6: Attend to precision.
- PRI 9: Demonstrate flexible use of strategies and methods while reflecting on which procedures seem to work best for specific types of problems.
- PRI 10: Reflect on mistakes and misconceptions to improve mathematical understanding

Sequence of Instruction

Activities Checklist

Engage

**Entry Event Commentary for the Teacher:** *In this lesson, students assume the role of a detective investigating a bank robbery. Students use four clues to help them apprehend the thief. This content is from a lesson titled “Highway Robbery” found at <http://illuminations.nctm.org/Lesson.aspx?id=3128>*

Below is a suspect matrix with the clue values needed to make a particular suspect the actual thief. Before class, choose one, and fill in the blanks on the Clue Sheet Overhead. The information you put on the Clue Sheet will lead the students to your chosen thief. You can also create your own suspect list, using people you make up or people you know, such as other teachers or classmates. Having two or three possible values for each characteristic makes it easier to have students find suspects to match their calculations.

**Suspect Matrix**

Roy G. Biv	Jen Eric	Matthew Matics
Clue 1 Question 1: 15 cm	Clue 1 Question 1: 13.2 cm	Clue 1 Question 1: 15 cm
Clue 2 Question 2: 25 pounds	Clue 2 Question 2: 25 pounds	Clue 2 Question 2: 32 pounds
Clue 3 Question 5: 16 miles/gallon	Clue 3 Question 5: 9 miles/gallon	Clue 3 Question 5: 8 miles/gallon
Polly Hedron	Evan Number	Al T. Tude
Clue 1 Question 1: 13.2 cm	Clue 1 Question 1: 13.2 cm	Clue 1 Question 1: 15 cm
Clue 2 Question 2: 32 pounds	Clue 2 Question 2: 25 pounds	Clue 2 Question 2: 32 pounds
Clue 3 Question 5: 8 miles/gallon	Clue 3 Question 5: 25 miles/gallon	Clue 3 Question 5: 16 miles/gallon

Give each student a pretend police badge as they enter the classroom. Explain they are police detectives today.

Address the class with an opening statement like, “Detectives, we have received an urgent email from the captain of police. We have been chosen for this task because of our superior math skills. I have created a copy of the note for everyone.” Display the Clue Sheet Overhead found below and at <http://illuminations.nctm.org/uploadedFiles/Content/Lessons/Resources/6-8/Clue%20Sheet%20OH.pdf>.

*Dear Detective,*

*Someone has robbed the National Bank of Illuminations in Washington D.C. It is your job to use the clues left by the perpetrators to locate and apprehend the robber. Your tools will be your power of deduction and your mathematical knowledge. Good luck cracking this case!*

*Sincerely, Captain P. Thagoras*

**CLUES:**

- The perpetrator is \_\_\_\_ cm tall in the security camera image.
- \_\_\_\_ pounds of quarters were stolen.
- The getaway car was a silver 1989 HN Cosine which travels \_\_\_\_ miles per gallon of gas.

## Explore

**PRI 1**  
**PRI 2**  
**PRI 4**  
**PRI 6**

Engage students in quantitative reasoning practices that include attending to the meaning of quantities and considering the units involved. Also, ask students to attend to precision as they utilize the clues to find the perpetrator.

**Commentary for the Teacher:** We recommend grouping students by like abilities throughout this activity. This will allow students to work at their own level and to be an active participant in the learning process.

Group students in pairs. Instruct students to find Task #1: Clue Activity Sheet in the Student Manual. Continue to display the Clue Sheet Overhead on the board.

*Teacher's Note:* The Task #1: Clue Activity Sheet can be found in the Student Manual and at [http://illuminations.nctm.org/uploadedFiles/Content/Lessons/Resources/6-8/Clue\\_Sheet\\_AS.pdf](http://illuminations.nctm.org/uploadedFiles/Content/Lessons/Resources/6-8/Clue_Sheet_AS.pdf).

INCLUDED IN THE STUDENT MANUAL

### Task #1: Clue Activity Sheet

# Clue Sheet

Dear Detective,

Someone has robbed the National Bank of Illuminations in Washington D.C. It is your job to use the clues left by the perpetrators to locate and apprehend the robber. Your tools will be your power of deduction and your mathematical knowledge. Good luck cracking this case!

Sincerely,  
Captain P. Thagoras

CLUES:

- The perpetrator is \_\_\_\_\_ cm tall in the security camera image.
- \_\_\_\_\_ pounds of quarters were stolen.
- The getaway car was a silver 1989 HN Cosine which travels \_\_\_\_\_ miles per gallon of gas.

INCLUDED IN THE STUDENT MANUAL

## Clues Sheet

NAME \_\_\_\_\_

Dear Detective,

Someone has robbed the National Bank of Illuminations in Washington D.C. It is your job to use the clues left by the perpetrators to locate and apprehend the robber. Your tools will be your power of deduction and your mathematical knowledge. Good luck cracking this case!

Sincerely,  
Captain P. Thagoras

### Clue 1

1. One surveillance camera was able to capture the image on the next page. The image shows the thief standing next to the door. In real life the door measures 84 inches but it is only 16.8 centimeters in the picture. If the person in the photo is \_\_\_\_\_ cm tall, how tall is suspect in real life? Report the height in feet and inches.

### Clue 2

2. The robber stole only \_\_\_\_\_ pounds of quarters out of the coin machine. Quarters are weighed in ounces. If there are 16 ounces in 1 pound, how many ounces of quarters were stolen?
3. Each quarter weighs 0.2 ounces. How much money has been stolen from the bank?

### Clue 3

4. A witness at the bank saw the getaway car stop at a nearby gas station. The gas station attendant said that the thief's tank was practically empty, and that he filled it completely. Luckily, he was also able to find the thief's receipt. Determine how many gallons of gas the thief purchased.





INCLUDED IN THE STUDENT MANUAL



 © 2009 National Council of Teachers of Mathematics  
<http://illuminations.nctm.org>  
Resources for Teaching Math

INCLUDED IN THE STUDENT MANUAL

5. The getaway car was a silver 1989 HN Cosine. The car gets \_\_\_\_\_ miles per gallon of gas. If the car continued until it ran out of gas again, how far could it go?

**Clue 4**

6. Using only one tank of gas, what is the farthest city that the thief can reach?

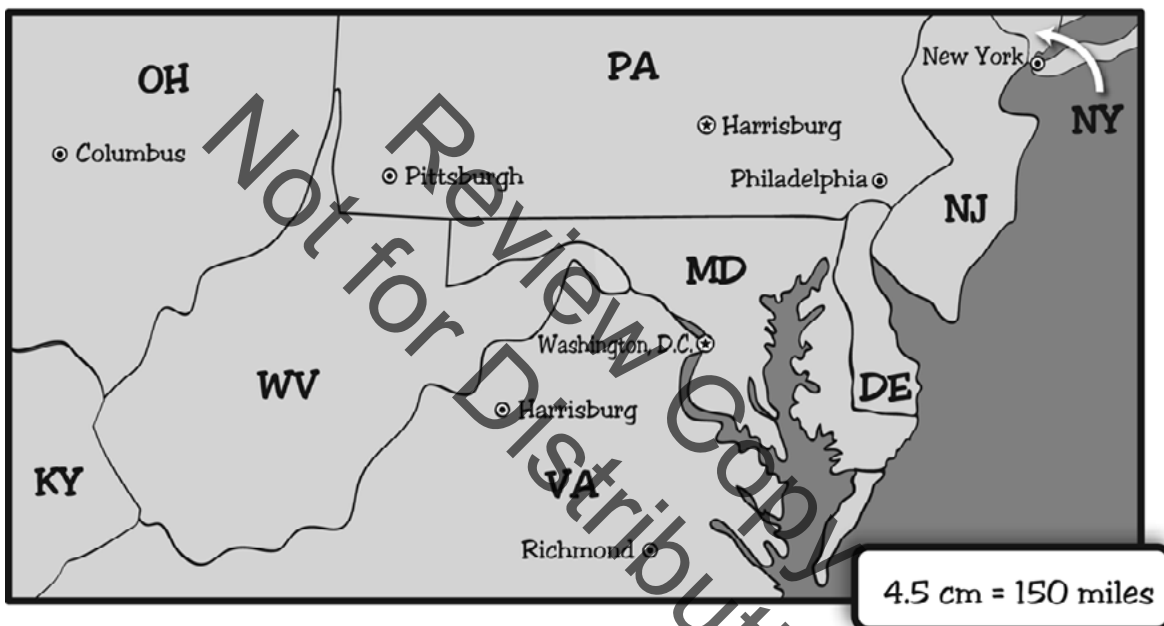

Facilitate a whole-class discussion about the clues. Students will contextualize mathematical ideas by connecting them to real-world situations. Ask students questions like the following:

- “What do you think the perpetrator would do with \_\_\_ pounds of quarters?”
- “If the perpetrator’s car gets \_\_\_ miles per gallon, do you think he/she is very far away?”

*Teacher’s Note: Some students, especially students whose first language is not English, may not be familiar with the vocabulary words perpetrator, apprehend, and deduction. As you read the letter, pause to ask for volunteers who can define each of these words.*

- *Perpetrator* – a person who committed the crime
- *Apprehend* – to arrest someone
- *Deduction* – to reach a conclusion

Instruct students to fill in the blanks in Questions 1, 2, and 5 on Task #1: Clue Activity Sheet. Instruct students to find Task #2: Suspect List Activity Sheet included in the Student Manual, which summarizes what is known about each person. Discuss Item 1 on Task #2: Suspect List Activity Sheet with the class and explain that students will need both Task #1: Clue Activity Sheet and Task #2: Suspect List Activity Sheet to find the perpetrator.

*Teacher’s Note: Task #2: Suspect List Activity Sheet can be found in the Student Manual and at [http://illuminations.nctm.org/uploadedFiles/Content/Lessons/Resources/6-8/Suspect\\_List%20AS.pdf](http://illuminations.nctm.org/uploadedFiles/Content/Lessons/Resources/6-8/Suspect_List%20AS.pdf).*







INCLUDED IN THE STUDENT MANUAL

### Task #2: Suspect List Activity Sheet

## Suspect List

NAME \_\_\_\_\_

1. Below is a list of possible suspects, their heights, where they were arrested, and how much stolen money they had. Use the answers from the Clue Sheet to select the culprit.

 <p>ROY G. BIV APPREHENDED IN PITTSBURGH, PA WITH \$500 HEIGHT: 6'3"</p>	 <p>JENERIC APPREHENDED IN PHILADELPHIA, PA WITH \$500 HEIGHT: 5'6"</p>	 <p>MATTHEW MATICS APPREHENDED IN RICHMOND, VA WITH \$640 HEIGHT: 6'3"</p>
 <p>POLLY HEDRON APPREHENDED IN HARRISBURG, PA WITH \$640 HEIGHT: 5'6"</p>	 <p>EVAN NUMBER APPREHENDED IN COLUMBUS, OHIO WITH \$500 HEIGHT: 5'6"</p>	 <p>AL T. TUDE APPREHENDED IN NEW YORK CITY WITH \$640 HEIGHT: 6'3"</p>

INCLUDED IN THE STUDENT MANUAL

2. Write a letter to the Captain explaining who you think is the thief. Make sure to justify your answer by explaining how you came to your decision.

Dear Captain,

Using the clues you have given me, I have deduced that \_\_\_\_\_  
is the person that robbed the bank.

Review Copy  
Not for Distribution

CASE  
CLOSED

Monitor students' work, and listen for students who are struggling. Students may have difficulty with answering Question 1 on Task #1: Clue Activity Sheet correctly. Some students will leave their answers as decimals, but the suspect list does not have decimal heights.

Here are some examples of guiding questions:

- What do you notice about the relationship between the missing information and the information given on the "Suspect List"?
- How can this relationship help you to solve this problem?
- Do any of your answers match the answers on the suspect list? What do you notice about the answers on the suspect list? So what do you have to do?
- *The most common problem will be students' making the decimal the number of inches, like 5.5 feet must be 5 feet 5 inches. Ask, "How many inches are in half a foot? Then, what should the height be?"*

**Commentary for the Teacher:** Students will use their answers from Clue 3 in Clue 4. After measuring the scale line in centimeters, a proportion will help them find the perpetrator's city. Be prepared to help students read a ruler. Remind them that the smaller lines represent millimeters, which are 0.1 centimeters.

## Explanation

**PRI 3**  
**PRI 9**  
**PRI 10**

Students will demonstrate flexible use of strategies and methods while reflecting on which procedures seem to work best for specific types of problems and reflect on mistakes and misconceptions to improve mathematical understanding. Students will also construct viable arguments and critique the reasoning of others using the following questions in a whole class discussion:

1. How did your group solve the problem? Does your group agree with this method?  
Explain. *[At this point, do not give evaluative feedback. Just allow students to share and critique.]*
2. What are some things in real life that would have affected the answers you got?  
*[Questions 2 and 3 assume that all the quarters weigh exactly the same. Question 6 assumes that the car was getting 25 miles per gallon. Gas mileage varies based on driving conditions, such as speed.]*
3. What is a tip you can give a student who is struggling to solve these problems? What possible misconceptions or mistakes do you think other students might make in completing this activity?

*Teacher's Note: Encourage students to make note of the methods and strategies they used in solving this problem to reflect on at the end of the unit.*

## Practice Together / in Small Groups / Individually

**PRI 1**

Students will continue working in the same pairs on the Robbery problem. At the end of this lesson, the teacher should make a note of misconceptions in the students' work. This will aid the teacher in future planning for this unit. This activity provides students with an opportunity to persevere when addressing problems of this type.

## Evaluate Understanding

---

Have students work backward. Assign different suspects to different pairs of students to create their own sets of clues. For example, assign one group the suspect “Matthew Matics”. This group uses the information on the “Suspect List” to work backward and create clues that would lead to this suspect. Then have students swap and try to find the new perpetrator.

INCLUDED IN THE STUDENT MANUAL

### Task #3: Lesson 1 - Exit Ticket

1. What methods/strategies did you and your partner use to solve this problem?
2. Summarize what you learned in this lesson.
3. How are the skills you used/learned in this lesson helpful in the real-world? Explain.

**Commentary for the Teacher:** Be sure students keep their work for this activity in their Student Manual because at the end of this unit students will return to this activity and discuss what new strategies they may use to solve this activity.

## Closing Activity

---

Reflection/Exit Slip:

## Resources/Instructional Materials Needed:

---

- Rulers
- Task #1: Clue Activity Sheet <http://illuminations.nctm.org/uploadedFiles/Content/Lessons/Resources/6-8/Clue%20Sheet%20A.pdf>
- Task #2: Suspect List Activity Sheet [http://illuminations.nctm.org/uploadedFiles/Content/Lessons/Resources/6-8/Clue\\_Sheet\\_AS.pdf](http://illuminations.nctm.org/uploadedFiles/Content/Lessons/Resources/6-8/Clue_Sheet_AS.pdf)
- Task #3: Lesson 1 - Exit Ticket [http://illuminations.nctm.org/uploadedFiles/Content/Lessons/Resources/6-8/Suspect\\_List%20AS.pdf](http://illuminations.nctm.org/uploadedFiles/Content/Lessons/Resources/6-8/Suspect_List%20AS.pdf)

## Ratio and Proportional Relationships

# Lesson 2 of 12

## Ratios

### Description:

---

In this lesson, students will learn what a ratio is and how it can be used in comparison. Students will also determine how to combine a sports drink in powder form and water to make enough for a whole football team. Students will be encouraged to use different strategies such as ratios and proportions.

### College- and Career-Readiness Standards Addressed:

---

- RP.1 Understand the concept of a ratio and use ratio language to describe a ratio relationship between two quantities.
- RP.2 Understand the concept of a unit rate  $a/b$  associated with a ratio  $a:b$  with  $b \neq 0$ , and use rate language in the context of a ratio relationship.
- RP.3 Use ratio and rate reasoning to solve real-world and mathematical problems.
- RP.4 Compute unit rates associated with ratios of fractions, including ratios of lengths, areas and other quantities measured in like or different units.

### Process Readiness Indicator(s) Emphasized:

---

- PRI 2: Reason abstractly and quantitatively by using multiple forms of representations to make sense of and understand mathematics.
- PRI 3: Describe and justify mathematical understandings by constructing viable arguments, critiquing the reasoning of other and engaging in meaningful mathematical discourse.
- PRI 4: Contextualize mathematical ideas by connecting them to real-world situations. Model with mathematics.
- PRI 7: Look for and make use of patterns and structure.



Sequence of  
Instruction

Activities Checklist

## Engage

### PRI 4

**Commentary for the Teacher:** We recommend grouping students by like abilities throughout this activity. This will allow students to work at their own level and to be an active participant in the learning process.

Students will contextualize mathematical ideas by connecting them to a real-world situation. Using a Think-Pair-Share Model, ask students:

“How many sugar packets do you think are inside a 20-oz bottle of soda? Guess as close as you can.” It may be helpful to have a 20 oz soda bottle to display for students to give them a frame of reference.

“Now give an answer you know is too high and an answer you know is too low.”

**Commentary for the Teacher:** In the Think-Pair-Share Model, a problem is posed, students have time to think about it individually and then they work in pairs to solve the problem and share their ideas with the class. Think-Pair-Share helps students develop conceptual understanding of a topic, develop the ability to filter information and draw conclusions, and develop the ability to consider other points of view.

Show students the Dan Meyer “Sugar Packets - Act one” video. <http://threeacts.mrmeyer.com/sugarpackets/>

At the end of the lesson, students will return to this scenario and will use real-world data involving ratios to accurately calculate the number of sugar packets inside a 20-oz bottle of soda.

## Explore

### PRI 2

Display the following ratio examples for your students. Students will reason abstractly and quantitatively by using multiple forms of representations to make sense of and understand mathematics.

- Americans prefer McDonald’s fries to Burger King fries at a ratio of 4 to 1.
- The ratio of dogs to cats in my neighborhood is 24 dogs to 8 cats.
- The ratio of red rocks to total rocks in the bowl is 82 red rocks to 125 rocks.
- The ratio of boys to girls at State University is  $\frac{1}{6}$ .
- The exchange rate is 1 dollar American: 0.94 Canadian.
- The mixture calls for 5 cups of white milk for every 2 cups chocolate milk.

Ask students to read these examples to themselves. With a partner, ask students to discuss if each statement is a part-to-part ratio, part-to- whole ratio, or is it comparing two different kinds of things? Discuss students’ responses as a whole group.

Remind students that it is important to understand ratios if we are going to determine how many sugar packets are in a 20-oz bottle of soda.

## Explanation

Many real-world problems involve scaling a ratio up or down to find an equivalent ratio. This requires making use of patterns and structure to find larger or smaller numbers with the same relationship as the numbers in the original ratio. Draw students' attention to the previous lesson and how ratios were used. For example, the ratio 1:2, 2:4, and 3:6 are all equivalent. Suppose a shade of green paint is made with 3 parts yellow paint mixed with 2 parts blue paint. You would get the same shade of green whether you mixed 3 gallons of yellow paint to 2 gallons of blue paint, 6 gallons of yellow paint to 4 gallons of blue paint, or 9 gallons of yellow paint to 6 gallons of blue paint. Ask students to determine other possible combinations for the following example: 5 parts cocoa to 2 part milk = \_\_\_ parts cocoa to \_\_\_ part milk.

If ratios were not used as a strategy during the "Sugar Packets" task, ask students:

- How might ratios have helped you solve the "Sugar Packets" problem?

Facilitate a whole-group discussion.

## Practice Together / in Small Groups / Individually

### PRI 4

**Commentary for the Teacher:** Before displaying the following information, be sure students understand the context. It's probable that many of them have never mixed up a sports drink before. Ask students: How many of you have ever mixed up Kool-Aid? At this point you may want to bring in a package of Kool-Aid or a sports drink powder and mix it with the proper amount of water and serve it to the class. This will give students a visualization of the situation that they are about to examine.

*Task #4: The Proper Mixture can be found in the Student Manual. (It was sourced from [http://alex.state.al.us/lesson\\_view.php?id=24076](http://alex.state.al.us/lesson_view.php?id=24076).)*

Instruct students to locate Task #4: The Proper Mixture in the Student Manual. Read the scenario with the class.

#### INCLUDED IN THE STUDENT MANUAL

### Task #4: The Proper Mixture

Johnny and Fred are the managers for their high school football team. The head coach of the team, Coach Grenade, fired last year's managers because they didn't know how to make the sports drink taste very good. It was always too sweet or too watery. The sports drink is made by mixing powder with water. Since the boys were just freshmen and they wanted to be managers next year, they decided to test some of their mixtures to see which one the players like the best.

The boys mixed up four different recipe combinations:

**Mix 1**  
1 cup power  
4 cups water

**Mix 2**  
2 cups power  
3 cups water

**Mix 3**  
3 cups power  
5 cups water

**Mix 4**  
3 cups power  
6 cups water

Making use of patterns and structure, “similar-ability” partners will, answer the following questions in the task.

1. Which mix will make the drink that is the sweetest? Explain. {Mix 2}
2. Which mix will make the drink that is the least sweet? Explain. {Mix 1}
3. Assume that each football player will drink 1 cup of sports drink. For each mix, how much powder and how much water are needed to make the sports drink for 75 football players? Explain.

Circulate and make sure students are not just using the amount of powder used as a marker for how sweet the drink will be. Encourage the students to make a table or drawings to aid in their understanding.

If students are having difficulties allow them to build visual representations. This can be done by giving the students green and white cubes and asking them to construct a model of the number of cups of powder and water are needed to make enough drink for 75 football players. Additional practice can be found using the following link: [http://www.transum.org/software/SW/Starter\\_of\\_the\\_day/Students/Ratio.asp](http://www.transum.org/software/SW/Starter_of_the_day/Students/Ratio.asp)

#### Extension

Students can create their own mixtures and trade with other groups to answer the same questions with the newly created mixtures. Have students discuss other methods that could be used to solve these questions (e.g., proportions).

### Evaluate Understanding

---

#### PRI 3

When group work is complete, call on students to share their reasoning to support their answers on the task. Students should construct viable arguments and critique the reasoning of others as they discuss their results, strategies they used, and explain why their results make sense.

### Closing Activity

---

Return to the “Sugar Packet” activity. (<http://threeacts.mrmeyer.com/sugarpackets/>)

Ask students, “What information will you need to know to solve the problem?”

Display the 2 images on the next page detailing nutritional information for a 20-oz bottle of soda and a sugar packet. Using this information, ask students to again determine “How many sugar packets do you think are inside a 20-oz bottle of soda? How accurate was your initial guess?” Discuss their findings as a whole group.

<b>Nutrition Facts</b>	
Serving Size 1 bottle	
Servings Per Container 1	
<b>Amount Per Serving</b>	
<b>Calories</b> 240	
<b>% Daily Value*</b>	
<b>Total Fat</b> 0g	<b>0%</b>
<b>Sodium</b> 75mg	<b>3%</b>
<b>Total Carbohydrate</b> 65g	<b>22%</b>
Sugars 65g	
<b>Protein</b> 0g	
Not a significant source of fat calories, saturated fat, trans fat, cholesterol, fiber, vitamin A, vitamin C, calcium and iron.	
*Percent Daily Values (DV) are based on a 2,000 calorie diet.	

<b>Nutrition Facts</b>	
Serving size 1 Teaspoon (4g )	
<b>Amount Per Serving</b>	
<b>Calories</b> 15	
<b>% Daily Value*</b>	
<b>Total Fat</b> 0g	<b>0%</b>
<b>Sodium</b> 0mg	<b>0%</b>
<b>Total Carbohydrate</b> 4g	<b>1%</b>
Sugars 4g	
<b>Protein</b> 0g	
*Percent Daily Values are based on a 2,000 calorie diet.	

Play the “Act Three” video to display the answer.

**INCLUDED IN THE STUDENT MANUAL**

**Task #5: Lesson 2 - Exit Ticket**

1. Summarize what you learned in this lesson.
2. How is this skill helpful in the real-world? Explain.
3. Would this skill have helped you in the opening activity, “Highway Robbery?” Explain.



## Ratio and Proportional Relationships

# Lesson 3 of 12

## Unit Rate

### Description:

---

Students will extend their understanding of ratios to solve unit rate problems including those involving constant speed. Students will use rate and unit rate to determine if a relationship is proportional.

### College- and Career-Readiness Standards Addressed:

---

- RP.3 Use ratio and rate reasoning to solve real-world and mathematical problems, e.g., by reasoning about tables of equivalent ratios, tape diagrams, double number line diagrams, or equations.
- RP.5 Recognize and represent proportional relationships between quantities. Decide whether two quantities are in a proportional relationship, e.g., by testing for equivalent ratios in a table or graphing on a coordinate plane and observing whether the graph is a straight line through the origin.

### Process Readiness Indicator(s) Emphasized:

---

- PRI 1: Make sense of problems and persevere in solving through reasoning and exploration.
- PRI 3: Describe and justify mathematical understandings by constructing viable arguments, critiquing the reasoning of others and engaging in meaningful mathematical discourse.
- PRI 4: Contextualize mathematical ideas by connecting them to real-world situations. Model with mathematics.
- PRI 6: Attend to precision.
- PRI 7: Look for and make use of patterns and structure.

Sequence of  
Instruction

Activities Checklist

## Engage

### PRI 1

**Commentary for the Teacher:** During this activity, help students to see that rates are a part of the ratio family discussed in the previous lesson. This activity and supporting materials can be found at <http://math.serpmedia.org/dragonfly/dragonfly.pdf>.

Share with students the following piece of information: “A common green dragonfly, the fastest insect in the world, can fly a distance of 50 feet in 2 seconds.”

In order to make sense of the problem, ask students:

- Has anyone ever seen a dragonfly? *Teacher’s Note: It may help to show students a few pictures of a dragonfly.*
- How long is 50 feet? *Students should know from their rulers how long one foot is but help them to understand 50 feet (20-25 steps for a typical adult) by finding a similar distance at the school so you can help them visualize the distance.*
- How long is two seconds? *Help the students visualize how fast that is. Have them picture a dragonfly flying the 50-foot distance in two seconds.*
- Can you run as fast as a dragonfly? *The world’s fastest sprinters run at about 35 feet per second.*

## Explore

### PRI 6

Group students in pairs based on similar abilities. Instruct students to find Task #6: Basic Dragonfly Prompt in their Student Manual. Ask students to create a math question that can be answered using the information in the statement. Explain they can provide more information in their question if necessary and should attend to precision, showing all work and answering the question they have created. Groups can use the handout to organize their work.

While students are working, look for pairs that have created examples of each of the three types of rate problems among those the students are making.

1. How long does it take to fly a [given] distance?
2. How far can it fly in a given time?
3. How fast is it going?

*Teacher’s Note: It is possible one type of problem will not be represented in students’ work. Create your own examples of each of the three types of rate problems prior to this lesson. You may need one of your problems to round out the list in the “Explanation” section.*

INCLUDED IN THE STUDENT MANUAL

### Task #6: Basic Dragonfly Prompt

HANDOUT 1



## Basic Dragonfly Prompt

A common green dragonfly, the fastest insect in the world, can fly a distance of 50 feet in 2 seconds.

1. Use a diagram, table, chart or other method to show this situation.

Not for Review Copy  
Distribution

2. Write the question that you are going to try to answer using this information, and then show your work on that question.

Your question:

---

---

work area



## Explanation

Select several groups to present their problems. Be sure all three types of problems are represented. If one type is missing, use a teacher-created problem. Ask students to classify the problems shared as:

- Find the time (how long did it take?)
- Find the distance (how far?)
- Find the rate (how fast?)

Facilitate a whole-group discussion.

## Practice Together / in Small Groups / Individually

**PRI 3**

**PRI 4**

Ask students to find Task #7: Three More Dragonfly Questions in their Student Manual. Display the following questions and ask students to use the spaces on the sheet to solve the problems:

INCLUDED IN THE STUDENT MANUAL

### Task #7: Three More Dragonfly Questions

1. How long does it take a dragonfly to fly 375 feet? 15 seconds
2. How far can it fly in 20 seconds? 500 feet
3. How fast is it going? 25 feet per second

Give students time to think independently, share with their same partner, and critique the reasoning of others.

**Commentary for the Teacher:** Do not show students how to solve the problems. The purpose of this activity is to elicit the variety of ways of thinking students use to solve the problem. Do not show students your way of thinking yet. You want students to provide examples along the progression of thinking. To see this progression refer to <http://math.serpmedia.org/dragonfly/dragonfly.pdf>.

Select three or four groups to present to the whole class. Presentations should span the learning progression beginning with the least sophisticated and progressing to the most. This will generally range from skip counting to using unit rate.

During the presentations, guide students to use the grade-level mathematics – the unit rate. As the presentations proceed, ask the class about the connections across presentations using questions like “How do parts of the first presentation correspond to parts of the second presentation?” After the last presentation, trace the connections and ask students how the different ways of thinking are related. Ask where the unit rate is in each way of thinking.

*Teacher’s Note:* Notice how it is hidden in the skip counting because you don’t need it to get an answer. It shows up in the table in the 1, 25 row. The unit rate is the grade-level mathematics students have to learn, so skip counters need to see and understand it in the tables and the equations. And the equation solvers need to see how it relates to tables and skip counting.

Questions to ask across the presentations:

1. What is the relationship between pairs of numbers in the tables?
2. Where is the unit rate in each way of thinking?

3. What would a slower insect look like in each way of thinking? Faster insect?
4. Which way of thinking is best for solving any problem, like with really big or really small numbers?

## Evaluate Understanding

Assess students' understanding of using unit rate to solve problems by having them independently complete Task #8: The Frog Problem in the Student Manual using two different ways of thinking.

INCLUDED IN THE STUDENT MANUAL

### Task #8: The Frog Problem

**HANDOUT 3**



## The Frog Problem

A frog can hop at a maximum speed of about 60 feet every 4 seconds.

How far can the frog go in 30 seconds? Show your work on this problem using two or three of the methods that were discussed in the dragonfly problem.

*work area*

© 2012 SERP      Dragonfly - Diagnostic Math Lesson      13

## Closing Activity

Select two or three students to present their solutions to pull student thinking along the progression to the target mathematics. Help students to see and understand the pros and cons of each method presented.

INCLUDED IN THE STUDENT MANUAL

### Task #9: Lesson 3 - Exit Ticket

1. Summarize what you learned in this lesson.
2. How is this skill helpful in the real-world? Explain.
3. Would this skill have helped you in the opening activity, "Highway Robbery?" Explain.

## Independent Practice

Assign Task #10: The Printer Problem.

INCLUDED IN THE STUDENT MANUAL

### Task #10: The Printer Problem

**HANDOUT 4**

**The Printer Problem**

A printer can print 3 high-quality photographs in 2 minutes.

How long will it take that printer to print 14 photos? Show 2 or 3 methods that you can use to understand and solve this problem.

*work area*

© 2012 SERP      Dragonfly - Diagnostic Math Lesson      14

**Resources/Instructional Materials Needed:**

---

- Task #6: Basic Dragonfly Prompt
- Task #7: Three More Dragonfly Questions
- Task #8: The Frog Problem
- Task #9: Exit Ticket
- Task #10: The Printer Problem

**Notes:**

Review Copy  
Not for Distribution

## Ratio and Proportional Relationships

# Lesson 4 of 12

## Proportional Reasoning

### Description:

---

Students will develop proportional reasoning skills by comparing quantities, looking at the relative ways numbers change, and thinking about proportional relationships in linear functions.

### College- and Career-Readiness Standards Addressed:

---

- RP.5 Recognize and represent proportional relationships between quantities.
  - a. Decide whether two quantities are in a proportional relationship, e.g., by testing for equivalent ratios in a table or graphing on a coordinate plane and observing whether the graph is a straight line through the origin.

### Process Readiness Indicator(s) Emphasized:

---

- PRI 1: Make sense of problems and persevere in solving through reasoning and exploration.
- PRI 3: Describe and justify mathematical understandings by constructing viable arguments, critiquing the reasoning of others and engaging in meaningful mathematical discourse.
- PRI 4: Contextualize mathematical ideas by connecting them to real-world situations. Model with mathematics.

Sequence of  
Instruction

Activities Checklist

## Engage

Play the video “World’s Biggest Burger” found at <https://www.youtube.com/watch?v=L4Y6VVdk2XY><https://www.youtube.com/watch?v=XqIWPvCgi9g>

Explain it takes 16 hours to cook 210 pounds of hamburger. The burger cooks down to a 140-pound patty. Ask students:

Why do you think the burger weighs 140 pounds after it’s cooked instead of 210 pounds? (The rest becomes grease.)

## Explore

### PRI 4

The following exercise will connect proportional reasoning to real-world situations and allow them to model with mathematics.

Ask students the following questions:

1. If you consume a burger that weighed 1 pound before cooking and assuming the weight of the original beef, beef that becomes grease, and final burger weight are proportional, what part of the original 1-pound burger should remain after cooking? ( $\frac{2}{3}$  pound)
2. If a restaurant wants to have a 400-pound patty after it has been cooked, what weight should they start out with? (600 pounds)
3. If your family bought one 360-pound burger from Mallies’ Sports Grill and each person ate a  $\frac{2}{3}$  pound serving every evening (and could keep it so that it wouldn’t spoil), how many days would your family be eating hamburger? NOTE: Assume the burger weighed 360 pounds after it was cooked. (Answers vary according to the number of people in a family. Two people would take 270 days. Three people would take 180 days. Four people would take 135 days. Five people would take 108 days.)

Facilitate a whole-group discussion about the answers, allowing students to share their answers as well as their processes for solving the problems.

## Explanation

### PRI 1

*Teacher’s Note: In this video, students will learn how ratios, tables, and graphs can help identify proportional relationships.*

Play the video at <http://www.pbslearningmedia.org/resource/muen-math-rp-proportionalrelationships/proportional-relationships/>.

In discussing the video afterward, emphasize that Carl needs to keep the ratio of juice to ginger ale consistent if he wants the punch to taste the same as he makes more and more. This is a multiplicative process; he has to double, triple, or quadruple the quantities of both the juice and the ginger ale for the punch to taste the same. Contrast this with what would happen if he started with a recipe of 2 cups of juice and 1 cup of ginger ale and added 1 more cup of each. Ask students:

- Would the punch taste more or less “juicy”? (less juicy)
- What if he added 5 cups of juice and 5 cups of ginger ale? (even less juicy)
- If Carl took this additive approach, would the punch taste the same as the original or different? (It would taste very different from the original recipe.)

*Teacher’s Note: This discussion should be connected with what was discussed when completing the sports drinks problem in the first lesson.*

**Commentary for the Teacher:** Proportional reasoning is at the core of many important concepts student will encounter. However, merely focusing on the procedure of finding the missing value in a proportion encourages students to apply rules without thinking and thus the ability to reason proportionally does not develop. Therefore, it is recommended that the instructor not introduce the cross-product algorithm until students have had many experiences with intuitive and conceptual methods. Help students to make sense of problems and persevere in solving them through reasoning and exploration.

### Practice Together / in Small Groups / Individually

#### PRI 3

*Teacher’s Note: In the classroom activity that accompanies the video, students use a classic mathematical task to improve their understanding of ratios and proportions.*

Group students with differing abilities in pairs. Instruct them to complete problems 1 and 2 on Task #11: Making Punch Worksheet in the Student Manual ([http://d43fweuh3sg51.cloudfront.net/media/media\\_files/muen\\_act\\_proportional\\_relationships.pdf](http://d43fweuh3sg51.cloudfront.net/media/media_files/muen_act_proportional_relationships.pdf)). This will give them the opportunity to critique the reasoning of others as well as justify their mathematical understandings by engaging in meaningful mathematical discourse.

By presenting them with problems that require them to think both multiplicatively and additively, students will develop their proportional reasoning skills. If needed, allow students to watch the video (<http://www.pbslearningmedia.org/resource/muen-math-rp-proportionalrelationships/proportional-relationships/>) again as they solve the problems on the worksheet.

Some of the mixtures provided on the worksheet will be proportional; however, many will not be. The students’ task is to use proportional reasoning techniques like doubling, halving, and relating to benchmark fractions to figure out how the different mixtures relate. Graphing the mixtures, as shown in the video, can also help them determine which mixture tastes more like juice.

INCLUDED IN THE STUDENT MANUAL

### Task #11: Making Punch Worksheet



## Making Punch Worksheet

1. Carl makes a punch using the following recipe:



Give two other recipes that would taste exactly the same.

Key	
	= Ginger ale
	= Juice

2. Look at the following recipes. Would each pair (a and b) taste the same? If not, which punch would taste more like plain juice? Use proportional reasoning, ratios, and graphs to help. Explain your reasoning for each.

<p>a. </p> <p>b. </p>	<p>a. </p> <p>b. </p>
<p>a. </p> <p>b. </p>	<p>a. </p> <p>b. </p>
<p>a. </p> <p>b. </p>	<p>a. </p> <p>b. </p>



INCLUDED IN THE STUDENT MANUAL

3. Write a punch recipe that uses at least five cups total of juice and ginger ale. Record the recipe below.

a. Write a recipe that is proportional (one that tastes the same) to the one you just created.

b. Write a recipe that is *less* juicy. What makes this recipe less juicy?

c. Write a recipe that is *more* juicy. What makes this recipe more juicy?

## Evaluate Understanding

### PRI 3

Review problems 1 and 2 on the worksheet as a class. Ask students to explain how they solved some of the problems in section 2.

KEY:

same	B
B	same
B	A

Examine their logic for examples of ratios and proportional reasoning. At the end of class, pick one recipe pair from the worksheet and make each version of the punch of juice and ginger ale. Have students taste test to see if they can tell which recipe is “punchier” or “juicier.” Students evaluate their own reasoning – Does the mathematics confirm the results of taste test?

Ask students to independently complete problems 3a, 3b, and 3c on Task #11: Making Punch Worksheet. After 10-15 minutes, ask several students to share their recipes and explain why they are more or less juicy than or taste the same as the original recipe.

## Closing Activity

### PRI 4

Either of the following activities can be used to capstone the lesson.

1) <http://ny.pbslearningmedia.org/resource/mket-math-rp-horsepark/horsepark/>

This lesson builds on a demonstration from a video of the length of Man o’ War’s stride versus the length of a person’s stride by allowing students to measure their own strides versus that of the great racehorse. This resource is part of the Math at the Core: Middle School Collection. Support materials are included.

2) <http://map.mathshell.org/lessons.php?unit=6230&collection=8>

This lesson unit is intended to help you assess how well students are able to reason proportionally when comparing the relationship between two quantities expressed as unit rates and/or part-to-part ratios. In particular, it will help you assess how well students are able to:

- Describe a ratio relationship between two quantities.
- Compare ratios expressed in different ways.
- Use proportional reasoning to solve a real-world problem.

Select a two or three students to present their solutions to pull student thinking along the progression to the target mathematics. Help students to see and understand the pros and cons of each method presented.

INCLUDED IN THE STUDENT MANUAL

### Task #12: Lesson 4 - Exit Ticket

1. Summarize what you learned in this lesson.
2. How is this skill helpful in the real-world? Explain.
3. Would this skill have helped you in the opening activity, “Highway Robbery?” Explain.

**Independent Practice:**

Students complete Task #13: Mammoth Mouthfuls in the Student Manual.

You are planning on opening your own large burger grill named “Mammoth Mouthfuls.” You will create huge burgers that can be cut up and shared by large groups. You will need to determine how much you will need of each ingredient and how much the burger should cost. A 4-pound total weight burger will cost \$12.00. Complete the table by reasoning your way from the 270-pound burger to get to the quantities of the 30-, 10- and 4-pound burgers.

INCLUDED IN THE STUDENT MANUAL

**Task #13: Mammoth Mouthfuls**

You are planning on opening your own large burger grill named “Mammoth Mouthfuls.” You will create huge burgers that can be cut up and shared by large groups. You will need to determine how much you will need of each ingredient and how much the burger should cost. A 4-pound total weight burger will cost \$12.00. Complete the table by reasoning your way from the 270-pound burger to get to the quantities of the 30-, 10- and 4-pound burgers.

Original weight of beef in pounds	Final weight of cooked beef in pounds	Weight of bun in pounds	Weight of cheese in pounds	Combined weight of toppings	Total pounds of burger (final weight of beef, bun cheese and toppings)	Cost
270	180	100	20	60	360	(1080)
$\frac{45}{2}$	15	$\frac{25}{3}$	$\frac{5}{3}$	5	30	(90)
$\frac{15}{2}$	5	$\frac{25}{9}$	$\frac{5}{9}$	$\frac{5}{3}$	10	(30)
3	2	$\frac{10}{9}$	$\frac{2}{9}$	$\frac{2}{3}$	4	\$12

Answers are in orange.

### Resources/Instructional Materials Needed:

---

- Graph paper
- Juice
- Ginger ale (or water)
- Making Punch video <http://www.pbslearningmedia.org/resource/muen-math-rp-proportionalrelationships/proportional-relationships/>.
- World's Biggest Burger Video <https://www.youtube.com/watch?v=L4Y6VVdk2XY>
- Task #11: Making Punch Worksheet
- Task #12: Lesson 4 - Exit Ticket
- Task #13: Mammoth Mouthfuls

### Notes:

---

The links below have additional tasks and problems to support this lesson.

- This lesson builds on a demonstration from a video of the length of Man o' War's stride versus the length of a person's stride by allowing students to measure their own strides versus that of the great racehorse. This resource is part of the Math at the Core: Middle School Collection. <http://ny.pbslearningmedia.org/resource/mket-math-rp-horsepark/horsepark/>
- The site includes hints and an additional video if students are showing any lack of confidence. <https://www.khanacademy.org/math/cc-seventh-grade-math/cc-7th-ratio-proportion/cc-7th-proportional-rel/e/analyzing-and-identifying-proportional-relationships>

## Ratio and Proportional Relationships

# Lesson 5 of 12

## Formative Assessment Lesson: Classifying Proportion and Non-Proportion Situations

### Description:

---

This lesson will assess whether students are able to identify when two quantities vary in direct proportion to each other; distinguish between direct proportion and other functional relationships; and solve proportionality problems using efficient methods.

From the Shell Center Formative Assessment Lesson:  
Classifying Proportion and Non-Proportion Situations

### College- and Career-Readiness Standards Addressed:

---

- RP Analyze proportional relationships and use them to solve real-world and mathematical problems.

### Process Readiness Indicator(s) Emphasized:

---

- PRI 1: Make sense of problems and persevere in solving through reasoning and exploration
- PRI 2: Reason abstractly and quantitatively by using multiple forms of representations to make sense of and understand mathematics.
- PRI 3: Describe and justify mathematical understandings by constructing viable arguments, critiquing the reasoning of others and engaging in meaningful mathematical discourse.
- PRI 5: Use appropriate tools strategically to support thinking and problem solving.
- PRI 6: Attend to precision.
- PRI 7: Look for and make use of patterns and structure.
- PRI 8: Look for and express regularity in repeated reasoning.
- PRI 9: Demonstrate flexible use of strategies and methods while reflecting on which procedures seem to work best for specific types of problems.
- PRI 10: Reflect on mistakes and misconceptions to improve mathematical understanding.

Students will engage in the Formative Assessment Lesson: Ratio and Proportional Relationships which can be found at:

<http://map.mathshell.org/download.php?fileid=1633>

The following *Formative Assessment Lesson* is a classroom-ready lesson included to help teachers assess and improve students' understanding of mathematical concepts and skills and their ability to use the mathematical process readiness indicators critical for college readiness.

Research has shown that formative assessment, as embodied in the following lesson, is a powerful way to improve student learning and performance. This approach first allows students to demonstrate their prior understandings and abilities in employing the mathematical processes, and then resolve their own difficulties and misconceptions through structured discussion. This results in more secure long-term learning, reducing the need for re-teaching that otherwise takes so much classroom time.

Many often ask, why don't students just remember the procedures they have been taught and practiced? The fact is, that approach works fine in the short term but, as every teacher knows, if procedural knowledge is not underpinned by conceptual understanding, students will quickly forget "how to do it."

Read more about the *Formative Assessment Lesson* rationale, structure, and philosophy using the *Brief Guide for Teachers and Administrators* that can be found at <http://map.mathshell.org/materials/index.php>.

Review Copy  
Not for Distribution

---

CONCEPT DEVELOPMENT

---

Mathematics Assessment Project  
**CLASSROOM CHALLENGES**  
A Formative Assessment Lesson

**Classifying Proportion  
and Non-proportion  
Situations**

Mathematics Assessment Resource Service  
University of Nottingham & UC Berkeley

For more details, visit: <http://map.mathshell.org>  
© 2015 MARS, Shell Center, University of Nottingham  
May be reproduced, unmodified, for non-commercial purposes under the Creative Commons license  
detailed at <http://creativecommons.org/licenses/by-nc-nd/3.0/> - all other rights reserved

**BEFORE THE LESSON**

**Assessment task: Getting Things in Proportion (15 minutes)**

Give this task, in class or for homework, a few days before the formative assessment lesson. This will give you an opportunity to assess the work and to find out the kinds of difficulties students have with it. You should then be able to target your help more effectively in the subsequent lesson.

Explain what you would like students to do:

- Read this task carefully.*
- Spend a few minutes answering the questions on the sheet. Make sure to explain all your reasoning carefully.*
- Do not be too concerned if you cannot finish everything. [Tomorrow] we will have a lesson on these ideas, which should help you to make further progress.*

It is important that, as far as possible, students are allowed to answer the questions without assistance. Some students may find it difficult to get started: be aware that if you offer help too quickly, students will merely do what you say and will not think for themselves. If, after several minutes, students are still struggling, try to help them understand what is required.

When all students have made a reasonable attempt at the task, reassure them that they will have time to revisit and revise their solutions later.

- Do not worry if you have struggled with completing this task. We will have a lesson [tomorrow] that should help you improve your work.*

### Getting Things in Proportion



**Q1. Leon**  
 Leon has \$40.  
**How many Mexican Pesos can Leon buy with his dollars?**  
 Explain how you figure this out.

**Q2. Minna**  
 This is the call plan for Minna's cell phone:  
*\$15 a month plus free texts plus \$0.20 per minute of call time.*  
 Minna made 30 minutes of calls this month, and 110 texts.  
**How much does she have to pay the phone company?**  
 Explain how you figure this out.

**Q3. Nuala**  
 Nuala drives to her grandma's.  
 She drives at 20 miles per hour.  
 The journey takes 50 minutes.  
**How long would the journey take if Nuala drove at 40 miles per hour?**  
 Explain how you figure this out.

**Q4. Orhan**  
 Orhan mixes some purple paint.  
 He uses three parts of blue paint for every five parts of red paint.  
 Orhan wants to mix more paint exactly the same color.  
 He has  $7\frac{1}{2}$  parts of red paint.  
**How much blue paint does he need?**  
 Explain how you figure this out.

**Exchange Rate**  
 \$1 US = 12  
 Mexican Pesos

**Q5.** Here are two statements about the math in Q1 to Q4 above.  
 For each question, decide which statements are **true**. Explain your answers.

	If you double one quantity, you double the other.	The ratio: first quantity : second quantity is always the same.
<b>Q1 Leon</b>	Dollars, Mexican Pesos	Dollars : Mexican Pesos
<b>Q2 Minna</b>	Minutes, Dollars	Minutes : Dollars
<b>Q3 Nuala</b>	Speed, Time	Speed : Time
<b>Q4 Orhan</b>	Blue paint, Red paint	Blue paint : Red paint



### Assessing students' responses

Collect students' responses to the task. Make some notes on what their work reveals about their current levels of understanding and any difficulties they encounter.

We suggest that you do not score students' work. Research shows that this will be counterproductive as it will encourage students to compare their scores and distract their attention from what they can do to improve their mathematics.

Instead, help students to make further progress by summarizing their difficulties as a series of questions. Some suggestions for these are given in the *Common issues* table on the next page. These have been drawn from common difficulties observed in trials of this unit.

We suggest you make a list of your own questions, based on your students' work. We recommend you either:

- write one or two questions on each student's work, or
- give each student a printed version of your list of questions and highlight the questions for each individual student.

If you do not have time to do this, you could select a few questions that will be of help to the majority of students and write these on the board when you return the work to the students in the follow-up lesson.

Common issues	Suggested questions and prompts
<p><b>Uses mental strategies</b></p> <p>For example: The student has calculated solutions, but written very little.</p>	<ul style="list-style-type: none"> <li>• Explain in more detail how you figured out your solution.</li> <li>• How can you make your mathematical reasoning clear to others?</li> </ul>
<p><b>Uses informal strategies</b></p> <p>For example: The student has used doubling and halving with addition.</p>	<ul style="list-style-type: none"> <li>• Can you think of a method that could be used for any quantity? E.g. What if you had ... cans of paint?</li> <li>• You had to do a lot of work to figure out that answer. Can you think of a more efficient way of solving this kind of problem?</li> </ul>
<p><b>Identifies the problem structure as additive rather than multiplicative when answering proportional questions</b></p> <p>For example: The student calculates <math>3 + 12\frac{1}{2}</math> (Q4).</p>	<ul style="list-style-type: none"> <li>• What is the relationship between red cans and blue cans of paint?</li> <li>• How many cans of blue paint would you use for one single red can? How can you use that in your solution?</li> </ul>
<p><b>Uses method of cross multiplying proportions when answering proportional questions</b></p> <p>For example: The student writes <math>\frac{17\frac{1}{2}}{x} = \frac{5}{3}</math>, which is correct, but manipulates the equation incorrectly (Q4).</p> <p>Or: The student writes: <math>\frac{x}{5} = \frac{17\frac{1}{2}}{3}</math>, which is incorrect (Q4).</p>	<ul style="list-style-type: none"> <li>• Which of these numbers relate to red paint? Blue paint? Explain how your method works.</li> </ul>
<p><b>Does not recognize when quantities vary in direct proportion</b></p> <p>For example: The student does not answer Q5.</p> <p>Or: The student says that the paint question (Q4) is not a proportional relationship.</p> <p>Or: The student claims that the cell phone question (Q2) is a proportional relationship.</p>	<ul style="list-style-type: none"> <li>• What properties must proportional relationships have?</li> <li>• Does this relationship have the following properties? <ul style="list-style-type: none"> <li>- It is a linear function;</li> <li>- if one quantity is zero so is the other;</li> <li>- if one quantity doubles, so does the other.</li> </ul> </li> </ul>
<p><b>Does not justify claims</b></p> <p>For example: The student distinguishes correctly between proportional and other functions, but does not explain how s/he made the distinctions.</p>	<ul style="list-style-type: none"> <li>• What properties do proportional relationships have?</li> <li>• How do you know this relationship is directly proportional?</li> </ul>
<p><b>Completes the task</b></p>	<ul style="list-style-type: none"> <li>• Write an interesting question from everyday life in which the quantities vary in direct proportion. Now answer your own question.</li> </ul>

### SUGGESTED LESSON OUTLINE

#### Whole-class introduction: *Properties of Direct Proportion (10 minutes)*

Students often incorrectly think that in proportional situations the figures in the problem influence the operation used in the calculation. One aim of this discussion is to address this misconception. Another aim is to check that students have vocabulary (‘proportional’, ‘quantities that vary in direct proportion’, and ‘proportional relationship’) to talk about that structure.

Give each student a mini-whiteboard, a pen, and an eraser.

Show Slide P-1 of the projector resource:

**Buying Cheese**

10 ounces of cheese costs \$2.40.

Ross wants to buy ..... ounces of cheese.

Ross will have to pay \$ .....



*This problem has some numbers missing.*

*Suggest two reasonable numbers to put in.*

Ask students to show you their mini-whiteboards and note down their ideas in a table on the board:

<b>Ounces bought</b>	10	100	20	5	15
<b>Total cost</b>	\$2.40	\$24	\$4.80	\$1.20	\$3.60

Ask students to share their methods. These will vary. Typically, some may use informal halving and adding strategies, such as:

10 ounces costs \$2.40, so 5 ounces costs \$1.20, so 15 ounces costs \$2.40 + \$1.20 = \$3.60.

*Are any of the numbers on the board easy to use? Why?*

*Now choose some harder numbers to use.*

Again ask students to show you their whiteboards and add their ideas to the table:

<b>Ounces bought</b>	10	100	20	5	15	8	27	3½
<b>Total cost</b>	\$2.40	\$24	\$4.80	\$1.20	\$3.60	\$1.92	\$6.48	\$0.84

You may find some students think you must divide when small numbers are used and multiply when large numbers are used.

*Mike, why did you choose these numbers?*

*How did you figure out the cost?*

*Does someone have a different method?*

*Which method do you prefer? Why?*

*So now we have a question that we could answer.*

Draw students' attention to the properties of direct proportion.

*What are the two quantities (variables) in this situation? [Ounces bought, total cost.]*

*What do you notice about the relationship between them?*

*How could you find the cost for any number of ounces in **one** step?*

*[One ounce costs 24 cents, so you could just multiply every amount by 0.24 to get the total cost.]*

Explain to students that the two variables are directly proportional to each other.

Now ask students for ideas on the properties of direct proportion. Write their ideas on the board.

Then ask the following questions in turn:

*How much would it cost if you buy zero ounces? [Zero dollars.]*

*What happens to the total cost if you double the amount you buy? [The cost doubles.]*

*What would a graph of this situation look like? [Straight line through origin.]*

*Make a sketch of the graph.*

After a few minutes ask two or three students with contrasting graphs to explain them. Encourage the rest of the class to ask questions and challenge their reasoning.

Slide P-2 of the projector resources summarizes the properties of direct proportion:

Properties of Direct Proportion
<ul style="list-style-type: none"><li>• One quantity is a multiple of the other.</li><li>• If the first quantity is zero, the second quantity is zero.</li><li>• If you double one quantity, the other also doubles.</li><li>• The graph of the relationship is a straight line through the origin.</li></ul>

Leave the list of properties on the board during the lesson. It is important that students have this Slide to refer to during the subsequent parts of the lesson.

**Collaborative small-group work (1): write your own questions (20 minutes)**

Organize students into pairs or groups of three.

Give each group a pack of cards from the lesson task *Direct Proportion or Not?* and explain to students what they are being asked to do:

*I've given you some cards relating to different situations.*

*There are two quantities in each situation, with blanks instead of numbers.*

*You are going to put numbers into these blanks and then classify the cards based on whether or not the two quantities vary in direct proportion.*

Display Slide P-3, which shows the instructions for working:

**Working Together**

Choose one of the cards to work on together.

1. Choose some easy numbers to fill in the blanks.  
Answer the question you have written.  
Write all your reasoning on the card.
2. Now choose harder numbers to fill in the blanks.  
Answer your new question together.  
Write all your reasoning on the card.
3. Decide whether the quantities vary in direct proportion.  
Write your answer and your reasoning on the card.

When you have finished one card, choose another.

Go through these carefully and check that students understand what they are being asked to do.

While students write their questions you have two tasks: to note different student approaches to the task and to support student learning/problem solving.

#### Note different student approaches

By carefully listening and watching students as they work together you will get a better idea of students' range of understanding, be in a better position to ask questions to help them progress, and be more purposeful in who you select to explain solutions to the whole-class.

Notice the methods students use to solve the problems. Do they use multiplication or informal doubling and halving strategies? Do they use the same methods when they introduce harder numbers? Do students choose efficient methods? Can they use those methods to solve problems accurately? Do students check their solutions and try to make sense of the answers? Are students able to identify the properties of direct proportion? Do they check all three properties from Slide P-2 before classifying?

#### Support student learning/problem solving

Try to support students' thinking and reasoning, rather than prompting them to use any particular method. You may find the questions in the *Common issues* table useful.

If the whole-class is struggling on the same issue, you could write one or two relevant questions on the board and hold a brief whole-class discussion.

Challenge students to use difficult numbers (with fractions or decimals) the second time they write on a card. Ask what methods students have used. Suggest that students try using the same method second time through.

*Is your method still effective?*

*Can you think of a method that will work, no matter how difficult the numbers?*

Ask questions to help students notice the properties of proportional relationships that have already been noted.

*Is the relationship between the amount of fuel and the cost directly proportional?*

*How do you know?*

Draw students' attention to other properties of direct proportion as they emerge in their work.

*What would the graph look like?*

*Can you change the numbers for this card (INTERNET or CELL PHONE) so that the quantities are directly proportional? [Put the fixed charge equal to zero.]*

Prompt students to compare cards:

*How are these two problems similar and how are they different?*

If students are progressing well, you could ask them to sketch on the cards the graphs of each situation.

**Collaborative small-group work (2): sharing questions and answers (15 minutes)**

Give each group a couple of blank *Swapping Questions* cards.

Ask students to pick a completed *Direct Proportion or Not?* card and copy it onto a blank *Swapping Questions* card.

*You are now going to exchange questions with another group.*

*You can pick the easy numbers version or the hard numbers version.  
Make sure you do not write in the answer!*

*Choose one that you think is a direct proportion question and another that is not.*

Give students a few minutes to copy out their questions.

Then ask them to exchange questions with a neighboring group.

*Work together as a pair.*

*Answer the questions the other group has given you.*

*Write all your calculations and reasoning on the card.*

*Decide which question is a direct proportion question and which is not and write reasons for your decisions.*

Give students time to work on this. Support them in recording all their calculations and reasons for decisions in writing.

As students are finishing, ask them to swap back and check each other's work.

Show Slide P-4 to help explain to students what they have to do:

**Analyzing Each Other's Work**

- Carefully read each solution in turn.
  - Is there anything you don't understand?
  - Do you notice any errors?
- Compare the work to your own solution to the question.
  - Have you used the same methods?
  - Do you have the same numerical answers?
- Do you agree about which question involves direct proportion?

After a few minutes, ask students to work again with their neighbor.

*Take turns to discuss any differences you see.*

*It is important that you all agree and understand the methods used.*

While students are working, observe and support as before. Notice whether students have any common errors or difficulties. It may be useful to discuss these as a whole-class. Note two or three questions for which there was disagreement for use in the whole-class discussion that follows.

**Whole-class discussion (15 minutes)**

You may find it helpful to use Slides P-5 to P-12 in the projector resource to support this discussion. These show the cards from the lesson task.

Begin by asking groups to choose a card that resulted in differences of opinion. Allow them to explain how they resolved these differences. Ask other students to compare the methods described with those they used on their own versions of the problem.

*Which story situations were the easiest for you to solve? What made them so?*

*Which of the story situations were the most challenging to solve? What made them so?*

*When you found that you were ‘stuck’, what did you do to get ‘unstuck’?*

*Did you solve your version of the question the same way?*

*Did anyone use a different method?*

Ask students to decide whether the group’s question is a proportion question. Ask them to explain why they agree or disagree with the decisions about direct proportionality, referring to the list of properties on Slide P-2.

*Is your version of the question a proportion question? How do you know?*

*Does anyone agree? How do you know?*

*Did anyone decide differently? What properties did you not find?*

Once students have reached an agreement about the classification of the card, encourage them to generalize.

*When you’re deciding whether or not it’s a proportion question, does it make any difference what numbers you put in? [It makes a difference to the cards INTERNET and CELL PHONE.]*

*Choose some numbers that make the relationship proportional. [Fixed cost = 0.]*

*How does the graph change? Show me. [Students may recognize that for the graph  $y = mx + b$ ; only when  $b = 0$  is the relationship directly proportional.]*

*Is there any difference between the graph representing the quantities for the INTERNET and the graph representing the quantities for the CELL PHONE? Show me.*

Students may note, for example, that INTERNET is directly proportional if they ignore the free minutes. This corresponds to changing the ‘zero’ on the time axis. All linear relationships can be converted to directly proportional relationships by a suitable translation of either variable.

Project Slide P-13 showing the following graphs:

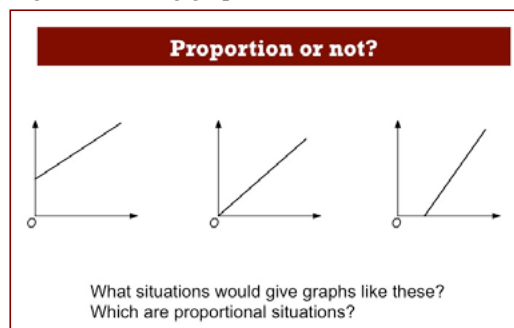

*Describe situations that could be represented by each of these graphs.  
Which are proportional and which are not?*

**Follow-up lesson: *Getting Things in Proportion (revisited)* (15 minutes)**

Give students their scripts from the first task, *Getting Things in Proportion* and a copy of the new task, *Getting Things in Proportion (revisited)*.

If you have not written questions on individual students' scripts, display your list of questions on the board now. Students can select from this list those questions they think apply to their own work.

*Do you recall the work about direct proportion? Remember how you wrote your own questions?*

*I would like you to spend some time reviewing your work. Read through your script and my questions carefully. Answer these questions and revise your response.*

*Now have a go at the new task, *Getting Things in Proportion (revisited)*. Can you use what you've learned to help you to answer these new questions?*

Some teachers like to give this task for homework.

Not for Review Copy  
Distribution



## SOLUTIONS

### Assessment task: *Getting Things in Proportion*

- Q1 This proportion question does not require a succinct or formal method and may elicit effective but inefficient use of repeated addition for multiplication, or strategies involving doubling and halving with addition. Two possible methods are shown below.

*Mental doubling.*

For each \$1 Leon could buy 12 Mexican Pesos.  
Doubling, for \$2 he could buy 24 Mexican Pesos.  
Doubling again, for \$4 he could buy 48 Mexican Pesos.  
Multiplying by 10, for \$40 he could buy 480 Mexican Pesos.

*Direct multiplication.*

For each \$1, Leon could buy 12 Mexican Pesos.  
For \$40, he could buy 40 times as much.  $40 \times 12 = 480$  Mexican Pesos.

- Q2 The cell phone plan is a linear but not a proportional relationship. Minna must pay  $\$15 + \$0.20x$ , where  $x$  is the number of minutes per month. (Students may try to make use of the number of texts, even though they are free and so do not contribute to cost.) Minna pays  $\$15 + \$0.20 \times 30 = \$15 + \$6 = \$21$ .
- Q3 Nuala takes 50 minutes when driving at 20 miles per hour. The distance is fixed. If she drives twice as fast, she will get there in half the time, in 25 minutes. (This is an ‘inverse proportional relationship’.) Students sometimes use an inefficient method that involves calculating her journey distance. They might calculate  $20 \times (50 \div 60)$  to find the distance in miles and then divide this answer by 40 to calculate the time in hours.
- Q4 As with Q1, this question involves a proportional relationship and students may make use of various effective but sometimes inefficient methods.

*Method A*

For 5 pints of red paint Orhan needs 3 pints of blue.  
For  $5 + 5 + 5$  pints of red,  $3 + 3 + 3$  pints of blue.  
For  $2\frac{1}{2}$  pints of red,  $1\frac{1}{2}$  pints of blue.  
So for  $17\frac{1}{2}$  pints of red paint, Orhan needs  $10\frac{1}{2}$  pints of blue paint.

*Method B*

The amount of red paint increases from 5 to  $17\frac{1}{2}$ .

This gives a scale factor of  $\frac{17\frac{1}{2}}{5} = \frac{35}{10} = 3.5$

The amount of blue paint required is  $3.5 \times 3 = 10.5$  or  $10\frac{1}{2}$  pints.

*Method C*

The amount of red paint per pint of blue paint is  $\frac{3}{5}$

So the amount of blue paint required for  $17\frac{1}{2}$  pints of red paint is

$$\frac{3}{5} \times 17\frac{1}{2} = \frac{3}{5} \times \frac{35}{2} = \frac{21}{2} = 10\frac{1}{2} \text{ pints.}$$

Q5

	<b>If you double one quantity, you double the other.</b>	<i>first quantity : second quantity</i> <b>This ratio is always the same.</b>
Q1 Leon	True. The number of Mexican Pesos is $12 \times$ the number of dollars. If you double the number of dollars, you double the number of Mexican Pesos. Students may show this by providing a few examples.	Dollars : Mexican Pesos True. The ratio is Dollars : Pesos = 1 : 12
Q2 Minna	False. Minna pays $\$15 + \$0.20x$ , where $x$ is the number of minutes of calls. If $x = 1$ , $\$15 + \$0.20 = \$15.20$ If $x = 2$ , $\$15 + \$0.20 \times 2 = \$15.40$ . $15.40 \neq 2 \times \$15.20$ .	Minutes : Dollars False. If $x = 1$ , $\$15 + \$0.20 = \$15.20$ giving 1 : 15.20. If $x = 10$ , $\$15 + \$2 = \$17$ giving 1 : 1.7.
Q3 Nuala	False. Doubling the speed halves the time it takes to cover the fixed distance to Grandma's house.	Speed (mph) : Time (minutes) False. If the speed is 20mph, the ratio is $20 : 50 = 2 : 5$ , but if the speed is 40 mph the ratio is $40 : 25 = 8 : 5$ .
Q4 Orhan	True. The ratio between the two quantities is fixed, so multiplying one quantity by a number increases the other quantity by the same factor.	Blue paint (pints) : Red paint (pints) True. The ratio is given as 3 : 5.

**Assessment Task: *Getting Things in Proportion (revisited)***

Again, students' methods may vary considerably so these solutions are only indicative.

- Q1 The cost of the taxi ride is not a proportional relationship. Cherie must pay  $\$4 + \$1.50x$ , where  $x$  is the number of miles. So the total cost is  $4 + 1.5 \times 7 = \$14.50$ .
- Q2 This is a proportional relationship. 13 cards at  $\$0.80$  per card is  $13 \times 0.8 = \$10.40$ .  
As before, this proportional question does not require a succinct or formal method, and may elicit effective but inefficient use of repeated addition for multiplication, or strategies involving doubling and halving with addition. For example, students may calculate  $10 \times 0.8 = 8$  and then add on  $0.8 + 0.8 + 0.8 = 2.4$  giving a total of  $\$10.40$ .
- Q3 In a scale drawing, the ratio between the length on the drawing and the real-life length is fixed. In this case, the width of the drawing of the room is 4"; the real room is 10' wide.  
So the ratio is 4" : 10' or 1" : 2.5'. So 12.5' in real life is 5" on the plan.  
Students may make a common error on ratio problems and see the relationship as additive. For example, a student might write:  
4" : 10'. 10' increases to 12.5'. Increase by 2.5. The line on the plan should be 6.5" long.
- Q4 This is not a proportional relationship. The time it takes to rise to the 5th floor is 40 seconds, but the lift then stops for 1 minute. After that, the lift continues to rise at a steady rate. In total, the lift takes  $15 \times 10 + 60 = 210$  seconds to reach the 16th floor. Note that a common error here is to multiply by 16 rather than 15.

Q5

	<b>If you double one quantity, you double the other.</b>	<i>first quantity: second quantity</i> <b>This ratio is always the same.</b>
Q1 Cherie	<p>False.</p> <p>Cherie pays <math>\\$4 + \\$1.50x</math>, where <math>x</math> is the number of miles.</p> <p>If <math>x = 1</math>, <math>\\$4 + \\$1.50 = \\$5.50</math>.</p> <p>If <math>x = 2</math>, <math>\\$4 + \\$3 = \\$7</math>.</p> <p>Doubling the number of miles does not double the fare.</p>	<p>Distance (miles) : Cost (\$)</p> <p>False.</p> <p>The ratio changes as the distance varies.</p>
Q2 Ellie	<p>True.</p> <p>The number of cards <math>\times</math> <math>\\$0.80</math> gives the price you pay.</p> <p>If you double the number of card you buy, you double the price you pay because this involves a fixed unit cost.</p>	<p>Number of cards : Cost (\$)</p> <p>True.</p> <p>The ratio is 1:0.8.</p>
Q3 Dexter	<p>True.</p> <p>Doubling the length on the plan doubles the length represented from the real room.</p> <p>If the line is 4" long, the real room is 10' long.</p> <p>If the line is 8" long, the real room is 20' long.</p>	<p>Length on drawing : length in room</p> <p>True.</p> <p>The ratio is 1:30.</p>
Q4 Fred	<p>False.</p> <p>The time taken to reach the fifth floor is 40 seconds. The time taken to reach the 10<sup>th</sup> floor is 90 second plus an extra 60 seconds, that is, 150 seconds in total.</p>	<p>Floor the lift has reached : Time (seconds)</p> <p>False.</p> <p>The ratio changes as the lift ascends.</p>

**Lesson task: Direct Proportion or Not?**

- Driving** The relationship between the variables is inverse proportion. Doubling the speed halves the time it takes to cover a fixed distance. In this case,  $s = d/t$ .
- Cell Phone** The relationship between the number of minutes and the cost may or may not be proportional, depending on the assumptions made. E.g. The relationship may be discrete, if fractions of minutes are rounded up to whole minutes in pricing.
- If the cost per month is nonzero, the relationship will be linear, but not directly proportional. In that case, if the number of minutes of use in a month is zero, the phone will cost whatever the student specifies as the monthly charge.
- If students decide that the cost per month is zero, the relationship will be one of direct proportion.
- Internet** The relationship between the GB used and the cost is directly proportional if zero GB are supplied free each month, otherwise the relationship is linear but not directly proportional.
- Map** The relationship between distances on the map and distances in real life is proportional.
- Toast** The relationship in 'Toast' involves a discrete function (the graph would be a step function). The toaster has two slots. Suppose it takes  $x$  minutes to toast two slices. If you make an even number of slices of toast,  $2n$ , it will take  $nx$  minutes to make all the toast.
- Suppose you make  $2n+1$  slices of toast ( $n = 0, 1, 2, \dots$ ). It will take as long to make the one extra slice as it would to make another two slices of toast. In that case, it will take  $(n+1)x$  minutes to make all the slices.

<i>number of slices</i>	1	2	3	4	5	6	7
<i>time</i>	$x$	$x$	$2x$	$2x$	$3x$	$3x$	$4x$

Students may also want to consider how long it would take to make a fractional part of a slice of toast!

- Smoothie** The relationships between the ingredients will all be proportional.
- Triangles** In the card 'TRIANGLES', similarity is a directly proportional relationship. The ratio between corresponding sides **within** each triangle stays the same as the triangle is scaled. If one side were zero, the other side would also be zero, so the graph of one length against another would pass through  $(0, 0)$ . The ratio of corresponding sides **between** two triangles is invariant. The numbers students put into the gaps will specify  $x$ .
- Line** Assume the straight line passes through the origin and the point  $(a, ka)$ . Then it will also pass through the point  $(x, kx)$  and the relationship between the coordinates is proportional.

## Getting Things in Proportion

### Q1. Leon

Leon has \$40.

**How many Mexican Pesos can Leon buy with his dollars?**

Explain how you figure this out.

Exchange Rate

\$1 US = 12  
Mexican Pesos

### Q2. Minna

This is the call plan for Minna's cell phone:

*\$15 a month plus free texts plus \$0.20 per minute of call time.*

Minna made 30 minutes of calls this month and 110 texts.

**How much does she have to pay the phone company?**

Explain how you figure this out.

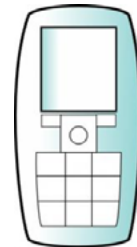

### Q3. Nuala

Nuala drives to her grandma's.

She drives at 20 miles per hour.

The journey takes 50 minutes.

**How long would the journey take if Nuala drove at 40 miles per hour?**

Explain how you figure this out.

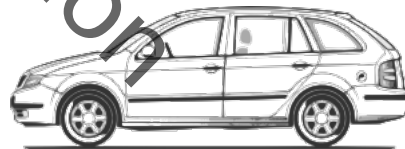

**Q4. Orhan**

Orhan mixes some purple paint.  
 He uses three pints of blue paint for every five pints of red paint.  
 Orhan wants to mix more paint exactly the same color.  
 He has  $17\frac{1}{2}$  pints of red paint.

**How much blue paint does he need?**

Explain how you figure this out.



**Q5.** Here are two statements about the math in Q1 to Q4 above.  
 For each question, decide which statements are true. Explain your answers.

**If you double one quantity,  
 you double the other.**

**The ratio:  
 first quantity : second quantity  
 is always the same.**

<b>Q1 Leon</b>	Dollars, Mexican Pesos	Dollars : Mexican Pesos
<b>Q2 Minna</b>	Minutes, Dollars	Minutes : Dollars
<b>Q3 Nuala</b>	Speed, Time	Speed : Time
<b>Q4 Orhan</b>	Blue paint, Red paint	Blue paint : Red paint

## Direct Proportion or Not? (1)

### DRIVING



If I drive at ..... miles per hour, my journey will take ..... hours.

How long will my journey take if I drive at ..... miles per hour?

### CELL PHONE

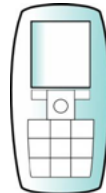

A cell phone company charges \$..... per month  
plus \$..... per call minute.

I used ..... call minutes last month.

How much did this cost?



## Direct Proportion or Not? (2)

### INTERNET



An internet service provides ..... GB  
(gigabites) free each month.

Extra GB used is charged at \$..... per GB.  
I used ..... GB last month. How much did this cost?

### MAP



A road ..... inches long on a map is ..... miles long in real life.

A river is ..... inches long on the map.  
How long is the river in real life?

### Direct Proportion or Not? (3)

#### TOAST



My toaster has two slots for bread.

It takes ..... minutes to make ..... slices of toast.

How long does it take to make ..... slices of toast?

#### SMOOTHIE



To make three strawberry smoothies, you need:

..... cups of apple juice

..... bananas

..... cups of strawberries

How many bananas are needed for ..... smoothies?

## Direct Proportion or Not? (4)

### TRIANGLES

These triangles are similar.

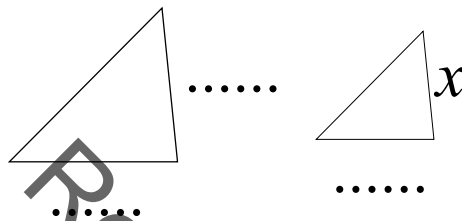

Calculate the length marked  $x$ .

### LINE

A straight line passes through the points  $(0, 0)$  and  $(\dots, \dots)$ .

It also passes through the point  $(\dots, y)$ .

Calculate the value of  $y$ .

## Swapping Questions



## Getting Things in Proportion (revisited)

### Q1. Cherie

Cherie wants to go home in a taxi.

She lives 7 miles away.

The taxi firm charges \$4 plus \$1.50 per mile.

**How much will the fare be?**

Explain how you figure this out.



### Q2. Ellie

Ellie is buying greeting cards.

The cards cost \$0.80 each.

She wants to buy 13 cards.

**How much will she pay the store clerk?**

Explain how you figure this out.



### Q3. Dexter

Dexter makes a scale drawing of his room.

In real life, the room is 10' wide and 12' 6" long.

In Dexter's drawing, the room is 4" wide.

**What measure should the length be?**

Explain how you figure this out.

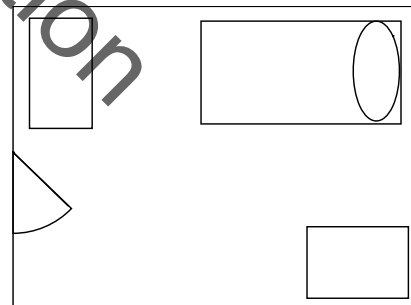

**Q4. Fred**

Fred lives on the 16<sup>th</sup> floor.

The elevator goes up one floor each 10 seconds.

It stops at the fifth floor for 1 minute for people to get out.

**How long does it take Fred to get to the 16<sup>th</sup> floor?**

Explain how you figure this out.



**Q5.** Here are some statements about the math in Q1 to Q4 above.

For each question, decide which statements are **true**. Explain your answers.

**If you double one quantity,  
 you double the other.**

**The ratio:  
 first quantity : second quantity  
 is always the same.**

<b>Q1 Cherie</b>	Distance, Cost	Distance : Cost
<b>Q2 Ellie</b>	Number of cards, Cost	Number of cards : Cost
<b>Q3 Dexter</b>	Length on drawing, Length in room	Length on drawing : Length in room
<b>Q4 Fred</b>	Time, Floor the lift has reached	Time : Floor the lift has reached

## Buying Cheese

10 ounces of cheese costs \$2.40.  
Ross wants to buy ..... ounces of cheese.  
Ross will have to pay \$ .....



## Properties of Direct Proportion

- One quantity is a multiple of the other.
- If the first quantity is zero, the second quantity is zero.
- If you double one quantity, the other also doubles.
- The graph of the relationship, is a straight line through the origin.



## Working Together

Choose one of the cards to work on together.

1. Choose some easy numbers to fill in the blanks.  
Answer the question you have written.  
Write all your reasoning on the card.
2. Now choose harder numbers to fill in the blanks.  
Answer your new question together.  
Write all your reasoning on the card.
3. Decide whether the quantities vary in direct proportion.  
Write your answer and your reasoning on the card.

When you have finished one card, choose another.

## Analyzing Each Other's Work

- Carefully read each solution in turn.
  - Is there anything you don't understand?
  - Do you notice any errors?
- Compare the work to your own solution to the question.
  - Have you used the same methods?
  - Do you have the same numerical answers?
- Do you agree about which question involves direct proportion?

# Driving

If I drive at ..... miles per hour,  
my journey will take ..... hours.



How long will my journey take  
if I drive at ..... miles per hour?

# Internet

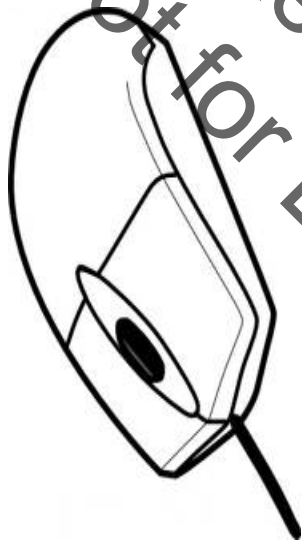

An internet service provides ..... GB  
(gigabytes) free each month.  
Extra GB used is charged at \$ ..... per GB.  
I used ..... GB last month.  
How much did this cost?

## Cell Phone

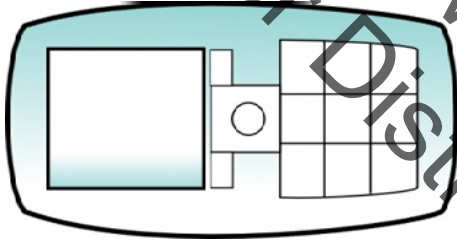

A cell phone company charges \$..... per month  
plus \$..... per call minute.  
I used ..... call minutes last month.  
How much did this cost?

# Map

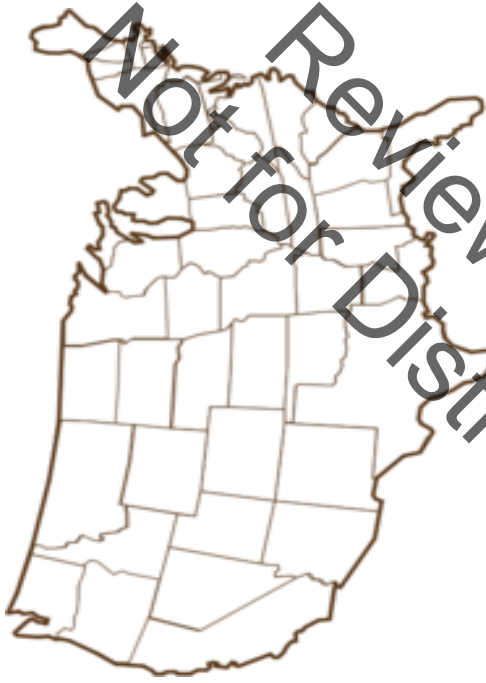

A road ..... inches long on a map  
is ..... miles long in real life.  
A river is ..... inches long on the map.  
How long is the river in real life?

# Toast



My toaster has two slots for bread.

It takes ..... minutes to make ..... slices of toast.

How long does it take to make ..... slices of toast?

# Smoothie

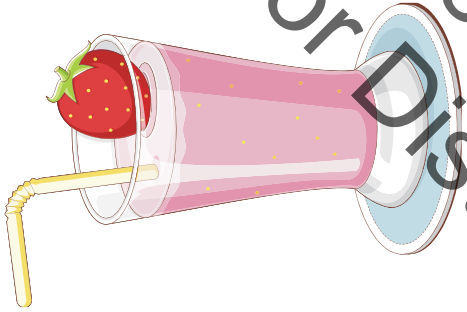

To make three strawberry smoothies, you need:

..... cups of apple juice

..... bananas

..... cups of strawberries

How many bananas are needed for .... smoothies?



# Triangles

**These triangles are similar.**

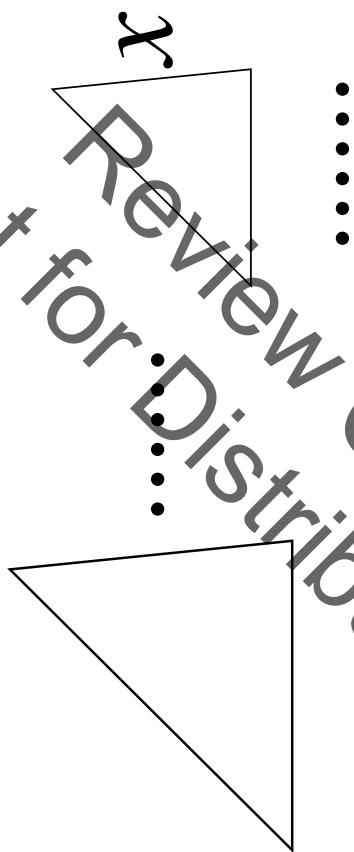

**Calculate the length marked  $x$ .**

## Line

A straight line passes through the points  $(0,0)$  and  $(\dots, \dots)$ .

It also passes through the point  $(\dots, y)$ .  
Calculate the value of  $y$ .

# Proportion or not?

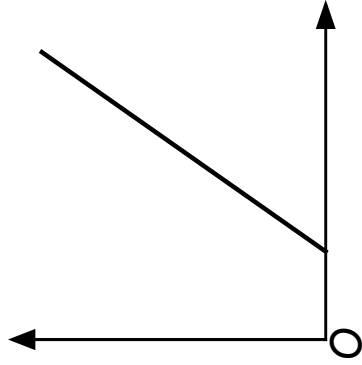
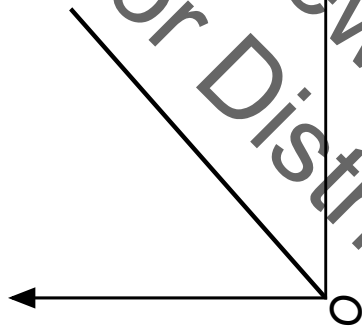
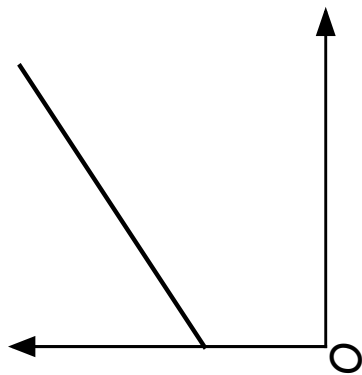

Review Copy  
Not for Distribution

What situations would give graphs like these?  
Which are proportional situations?

## Mathematics Assessment Project **Classroom Challenges**

These materials were designed and developed by the  
Shell Center Team at the Center for Research in Mathematical Education  
University of Nottingham, England:

**Malcolm Swan,**  
**Nichola Clarke, Clare Dawson, Sheila Evans, Colin Foster, and Marie Joubert**  
with  
**Hugh Burkhardt, Rita Crust, Andy Noyes, and Daniel Pead**

We are grateful to the many teachers and students, in the UK and the US,  
who took part in the classroom trials that played a critical role in developing these materials

The classroom observation teams in the US were led by  
**David Foster, Mary Bouck, and Diane Schaefer**

This project was conceived and directed for  
The Mathematics Assessment Resource Service (MARS) by  
**Alan Schoenfeld** at the University of California, Berkeley, and  
**Hugh Burkhardt, Daniel Pead, and Malcolm Swan** at the University of Nottingham

Thanks also to Mat Crosier, Anne Floyde, Michael Galan, Judith Mills, Nick Orchard, and Alvaro Villanueva who contributed to the design and production of these materials

This development would not have been possible without the support of  
**Bill & Melinda Gates Foundation**

We are particularly grateful to  
**Carina Wong, Melissa Chabran, and Jamie McKee**

The full collection of Mathematics Assessment Project materials is available from

<http://map.mathshell.org>

© 2015 MARS, Shell Center, University of Nottingham  
This material may be reproduced and distributed, without modification, for non-commercial purposes,  
under the Creative Commons License detailed at <http://creativecommons.org/licenses/by-nc-nd/3.0/>  
All other rights reserved.  
Please contact [map.info@mathshell.org](mailto:map.info@mathshell.org) if this license does not meet your needs.

## Ratio and Proportional Relationships

# Lesson 6 of 12

## Proportions

### Description:

---

In this lesson, students will work with relationships in which two quantities vary together. They will understand the multiplicative nature of proportional reasoning and develop a variety of strategies for solving proportion and ratio problems.

### College- and Career-Readiness Standards Addressed:

---

- RP.5 Recognize and represent proportional relationships between quantities.
  - a. Decide whether two quantities are in a proportional relationship, e.g., by testing for equivalent ratios in a table or graphing on a coordinate plane and observing whether the graph is a straight line through the origin.

### Process Readiness Indicator(s) Emphasized:

---

- PRI 1: Make sense of problems and persevere in solving through reasoning and exploration
- PRI 2: Reason abstractly and quantitatively by using multiple forms of representations to make sense of and understand mathematics.
- PRI 7: Look for and make use of patterns and structure.
- PRI 8: Look for and express regularity in repeated reasoning.
- PRI 9: Demonstrate flexible use of strategies and methods while reflecting on which procedures
- PRI 10: Reflect on mistakes and misconceptions to improve mathematical understanding.

Sequence of  
Instruction

Activities Checklist

Engage

PRI 9

Play the video of the Statue of Liberty at <http://www.watchknowlearn.org/Video.aspx?VideoID=25172&CategoryID=3746> or a similar site.

Ask students:

- The Statue of Liberty's nose is 4 feet 6 inches long from the bridge to the tip. How long do you think her right arm is? *Teacher's Note: Her right arm is the one holding the torch.*

Create a list of students' guesses on the board.

Explore

PRI 1  
PRI 10

Form groups of three to four students by differing ability. Each student is to assume one of the following roles: recorder, calculator, task master and presenter. Distribute string, rulers, and calculators. Explain students can use these tools to determine the length of the Statue of Liberty's right arm. Allow each group to decide on their problem solving strategies and methods and to proceed on their own.

*Teacher's Note: Students can solve this problem without knowing formal procedures for solving proportions. However, if students completed Lesson 5 of this unit (the Formative Assessment Lesson) remind them to utilize those same strategies in this activity.*

Allow 15-20 minutes for students to create posters that show their strategies as well as their solutions. Each group should post their chart paper so all strategies can be compared. To allow students time to reflect on their mistakes and misconceptions, conduct a gallery wall, having each group visit the other posters and consider the following questions:

- How was your strategy different than this group's strategy?
- How accurate do you think this group's strategy is? Explain.

*Teacher's Note: The actual length of the Statue of Liberty's arm is 42 feet according to <http://www.nps.gov/stli/learn/historyculture/statue-statistics.htm>*

Facilitate a whole-group discussion about students' strategies and solutions. Ask questions such as:

- Which strategy was the easiest to understand? Why?
- Which strategy did you like best? Why?
- How could you improve your strategy?

**Commentary to the Teacher:** Help students to see the proportional relationship represented in this scenario.

If some groups did not arrive at 42 feet, explore possible reasons for the discrepancies. Answers may include: the measure of their nose might not have been from the bridge to the tip; her body is not in proportion; her arm and torch would look too long if it were in proportion; if the arm is too long, it may not be able to withstand the weather and time; the artist did not know mathematics.

## Explanation

**PRI 7**  
**PRI 2**

A proportion is a name we give to a statement that two ratios are equal. Have each student compare the ratios of the measurement of the length of their nose to the length of their arm, the length of their foot to the length of their leg, etc. Are the ratios proportional? Based on the class data, and making use of patterns and structure, ask students to either support an argument for or against making a generalized statement concerning this ratio.

## Practice Together / in Small Groups / Individually

**PRI 9**

For this activity, students will work in groups of two. Give each group 10 jumbo and 16 standard paper clips. One person of the group will measure objects with a chain of jumbo paper clips and the other student with a chain of standard clips. Have students measure and record the lengths of five objects in the room in both jumbo and standard paper clip units on Task #14: Paper Clip Comparisons in the Student Manual.

INCLUDED IN THE STUDENT MANUAL

### Task #14: Paper Clip Comparisons



Object Measured	Jumbo Clips Long	Standard Clips Long

Students will make a coordinate graph of their data and answer the questions on the task.

- What is the independent variable for the coordinate graph?
- What is the dependent variable?
- What patterns do you see? (Be sure to use mathematical language.)
- How could you use that pattern to determine something in standard clips if you knew how long it was in jumbo clips?

## Evaluate Understanding

### PRI 8

Facilitate a whole-group discussion about students' graphs and answer to the questions. Assess students' answers and explanations to Task #14: Paper Clip Comparisons. Students should see there is a proportional relationship (understanding the multiplicative nature of proportional reasoning) between the regular paper clips and the jumbo paper clips – **it takes 1.5 regular paper clips to match the length of one jumbo paper clip.**

## Closing Activity

INCLUDED IN THE STUDENT MANUAL

### Task #15: Proportion Practice

1. Each of the data sets represents points on a line. In which table is one variable directly related to the other? Fill in the missing entry in each table.

x	y
0	4
10	19
16	

x	y
0	0
10	15
16	

Plot the data from the tables in the previous question on the same set of axes and use a ruler to draw a line through each set of points. By looking at the graph, how could you recognize the direct variation? What similarities and differences are there between the two lines drawn?

2. Create a proportion from each set of numbers. Only use 4 numbers from each set of numbers.

1. 6, 2, 9, 3	2. 4, 2, 32, 1, 8
3. 12, 24, 5, 10	4. 13, 12, 20, 4, 39

#### Possible Answers:

- In which table is one variable directly related to the other? (table on the right)  
Fill in the missing entry in each table. First table  $Y = \frac{3}{2}X + 4$ , If  $X = 16$  then  $Y = 28$ , second table  $Y = \frac{3}{2}X$ , If  $X = 16$  then  $Y = 24$
1.  $(\frac{2}{6} = \frac{3}{9})$  Answers may vary. E.g.,  $\frac{9}{3} = \frac{6}{2}$  would also be correct.  
2.  $(\frac{8}{32} = \frac{1}{4})$  Answers may vary  
3.  $(\frac{12}{24} = \frac{5}{10})$  Answers may vary  
4.  $(\frac{13}{39} = \frac{4}{12})$  Answers may vary



INCLUDED IN THE STUDENT MANUAL

**Task #16: Lesson 6 - Exit Ticket**

1. Summarize what you learned in this lesson.
2. How is this skill helpful in the real-world? Explain.
3. Would this skill have helped you in the opening activity, “Highway Robbery?” Explain.

**Independent Practice:**

INCLUDED IN THE STUDENT MANUAL

**Task #17: Mixing Paint**

1. Bobby was mixing blue paint and yellow paint in the ratio of 2:3 to make green paint. He wants to make 45 liters of green paint. He began to make a table to help him think about the problem but is unsure of what to do next.

Liters of Blue Paint	Liters of Yellow Paint	Liters of Green Paint
2	3	5
4	6	10

- a.) Explain how to continue to add values to the table.
- b.) Write an explanation to Mark about how he can use his table to find how many liters of blue paint and how many liters of yellow paint will he need to make 45 liters of green paint.
- c.) Mark decides to buy 15 liters of blue paint. He still wants to mix blue paint and yellow paint in the ratio of 2:3 to make green paint. How many liters of yellow paint should he buy, and how many gallons of green paint he can make?

Use mathematical reasoning to justify your answer.

Possible Answers:

- (18 and 27)
- (14, 21)
- (Will only use 14 liters of blue)

INCLUDED IN THE STUDENT MANUAL

### Task #18: Racing Robots

1. Carli's class built some solar-powered robots. They raced the robots in the parking lot of the school. The graphs below are all line segments that show the distance  $d$ , in meters, that each of three robots traveled after  $t$  seconds.
  - a.) Each graph has a point labeled. What does the point tell you about how far that robot has traveled?
  - b.) Carli said that the ratio between the number of seconds each robot travels and the number of meters it has traveled is constant. Is she correct? Explain.
  - c.) How fast is each robot traveling? How did you compute this from the graph?

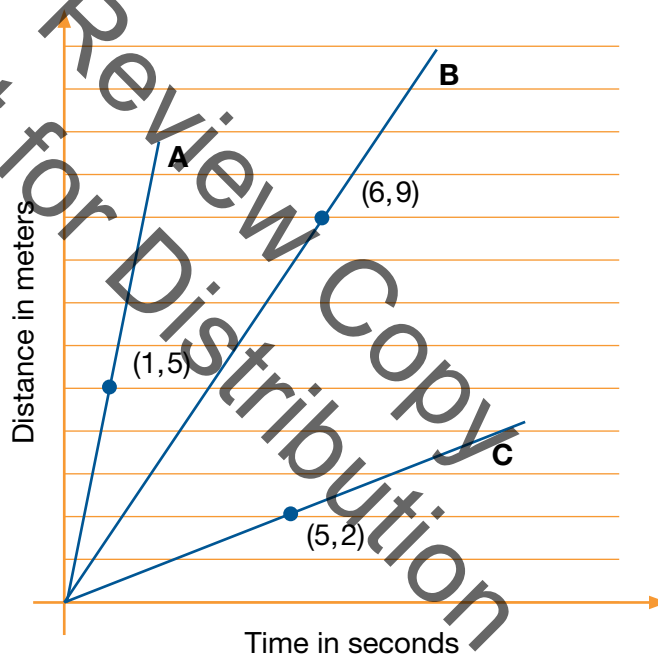

The answers are:

- a.) The point (1, 5) tells that robot A traveled 5 meters in 1 second. The point (6, 9) tells that robot B traveled 9 meters in 6 seconds. The point (5, 2) tells that robot C traveled 2 meters in 5 seconds.
- b.) Carli is correct. Whenever the ratio between two quantities is constant, the graph of the relationship between them is a straight line through (0,0). We can also say that for each robot, the relationship between the time and distance is a proportional relationship.
- c.) The speed can be seen as the  $d$ -coordinate of the graph when  $t=1$ . This is the robot's unit rate: Robot A traveled 5 meters per second, as shown by the point (1, 5) on its graph. Robot B traveled 1.5 meters per second, as shown by the point (1, 1.5) on its graph. Robot C traveled 0.4 meters per second, as shown by the point (1, 0.4) on its graph.

*Teacher's Note: The speed of each robot can also be seen in the steepness of its graph, which is quantified as slope.*

Activity from <https://www.illustrativemathematics.org/content-standards/tasks/181>

### Resources/Instructional Materials Needed:

---

- Jumbo and standard paper clips
- Rulers
- String
- Computer access
- Chart paper
- Colored markers
- <http://www.watchknowlearn.org/Video.aspx?VideoID=25172&CategoryID=3746>
- Task #14: Paper Clip Comparison
- Task #15: Proportion Practice
- Task #16: Lesson 6 - Exit Ticket
- Task #17: Mixing Paint
- Task #18: Racing Robots

### Additional Practice:

---

Dan Meyer's "Leaky Faucet" task found at <http://www.101qs.com/423>.

## Ratio and Proportional Relationships

# Lesson 7 of 12

## Identifying Similar Figures Using Proportionality

### Description:

---

In this lesson students will learn about similar figures, corresponding sides and scale factors.

### College- and Career-Readiness Standards Addressed:

---

- RP.5 Recognize and represent proportional relationships between quantities.
  - a. Decide whether two quantities are in a proportional relationship, e.g., by testing for equivalent ratios in a table
  - b. Identify the constant of proportionality (scale factor) in tables, graphs, equations, diagrams, and verbal descriptions of proportional relationships.
  - c. Represent proportional relationships by equations. For example, if total cost  $t$  is proportional to the number  $n$  of items purchased at a constant price  $p$ , the relationship between the total cost and the number of items can be expressed as  $t = pn$ .
  - d. Explain what a point  $(x, y)$  on the graph of a proportional relationship means in terms of the situation, with special attention to the points  $(0, 0)$  and  $(1, r)$  where  $r$  is the unit rate.

### Process Readiness Indicator(s) Emphasized:

---

- PRI 1: Make sense of problems and persevere in solving through reasoning and exploration
- PRI 2: Reason abstractly and quantitatively by using multiple forms of representations to make sense of and understand mathematics.
- PRI 3: Describe and justify mathematical understandings by constructing viable arguments, critiquing the reasoning of others and engaging in meaningful mathematical discourse.
- PRI 7: Look for and make use of patterns and structure.
- PRI 8: Look for and express regularity in repeated reasoning.

Sequence of  
Instruction

Activities Checklist

Engage

**PRI 1**  
**PRI 3**

*Teacher's Note: To save instructional time, print on card stock and cut out the triangles for this lesson prior to class. Also, this activity can be found at <http://www.uen.org/Lessonplan/preview.cgi?LPid=20100>*

Place students in groups of 2 or 3 based on similar ability. Display the triangles on the board. Ask students to locate Task #19: Triangles in the Student Manual.

INCLUDED IN THE STUDENT MANUAL

**Task #19: Triangles**

How could you group these triangles based on similar characteristics? Explain your grouping strategy using words.



Allow students a few minutes to come up with a way to group the triangles. Instruct them to answer the question in their Student Manual.

Select several groups with different strategies to share their explanations. Facilitate a whole-class discussion and encourage students to construct viable arguments and critique the reasoning of others. Ask probing questions, such as:

- Which of the strategies did you like best? Why?
- Which group's reasoning and explanations made the most sense? Why?

## Explore

PRI 7

PRI 8

Using repeated reasoning and making use of patterns, this discussion should bring out the topic of similar triangles. If it does not, guide students in this direction by asking them to label the triangles as in the image below.

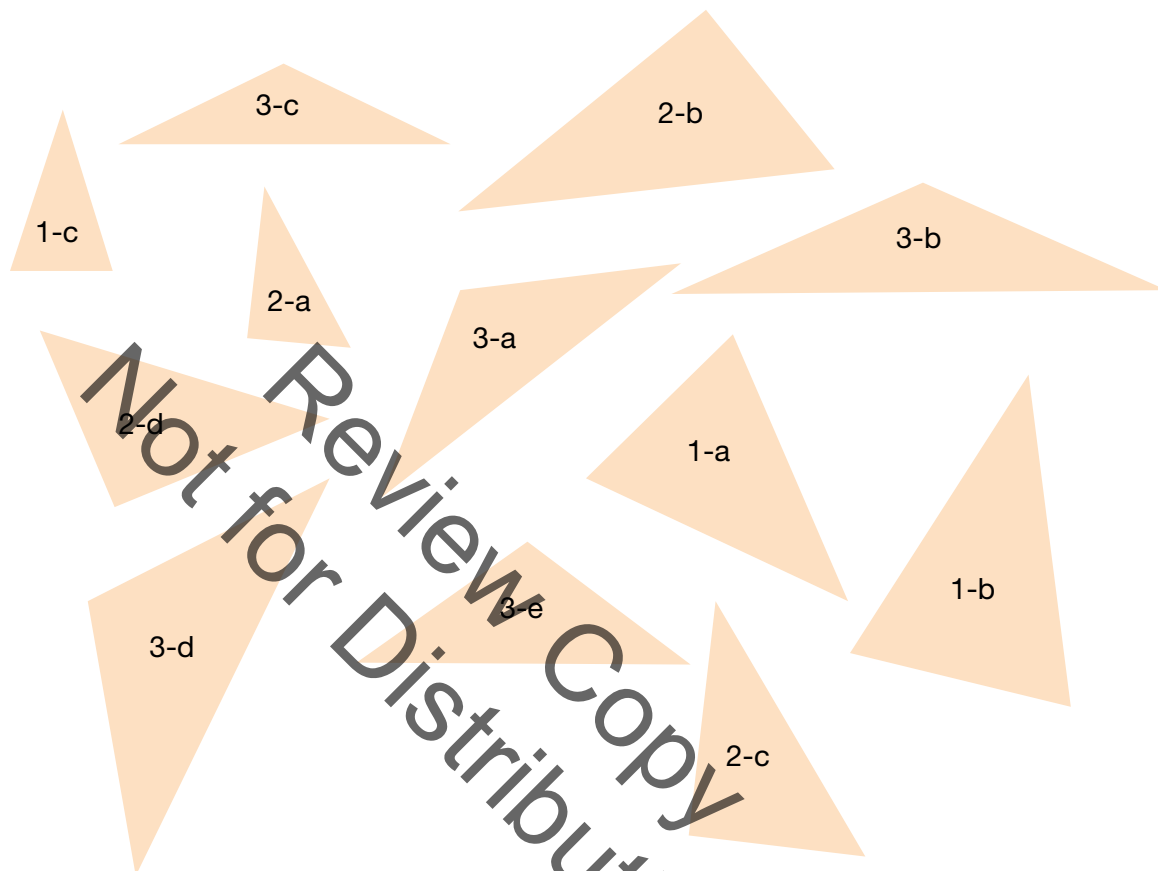

Hold up the triangles from Group 1. Match the corresponding angles by placing one triangle on top of the other, lining up the corners. Do this for each pair of corresponding angles. Ask students:

- What do you notice about the angles in these triangles? (The angles are congruent.)
- So if the angles are congruent, what can be said about these triangles? (They are similar figures.)

Repeat the process for the triangles in Group 2 and Group 3.

**Commentary for the Teacher:** Students should realize the corresponding angles of the similar triangles are congruent. To prove this, have them check by measuring each angle with a protractor. To save time, you could assign one-third of the class to examine the triangles in Group 1, another one-third to Group 2, and the last one-third to Group 3.

Once students have the understanding that the corresponding angles in similar figures are congruent, they can investigate how to use scale factor, which they will learn about in this lesson, and corresponding side lengths. Ask students:

- What does corresponding side lengths mean? *(They are the lengths of the corresponding sides of similar figures. Each pair of corresponding side lengths in similar figures will be proportional.)*
- How can we find corresponding sides for each of our triangles in our groups?

Have the students label the corresponding side lengths of the triangles in their Student Manual using the appropriate markings.

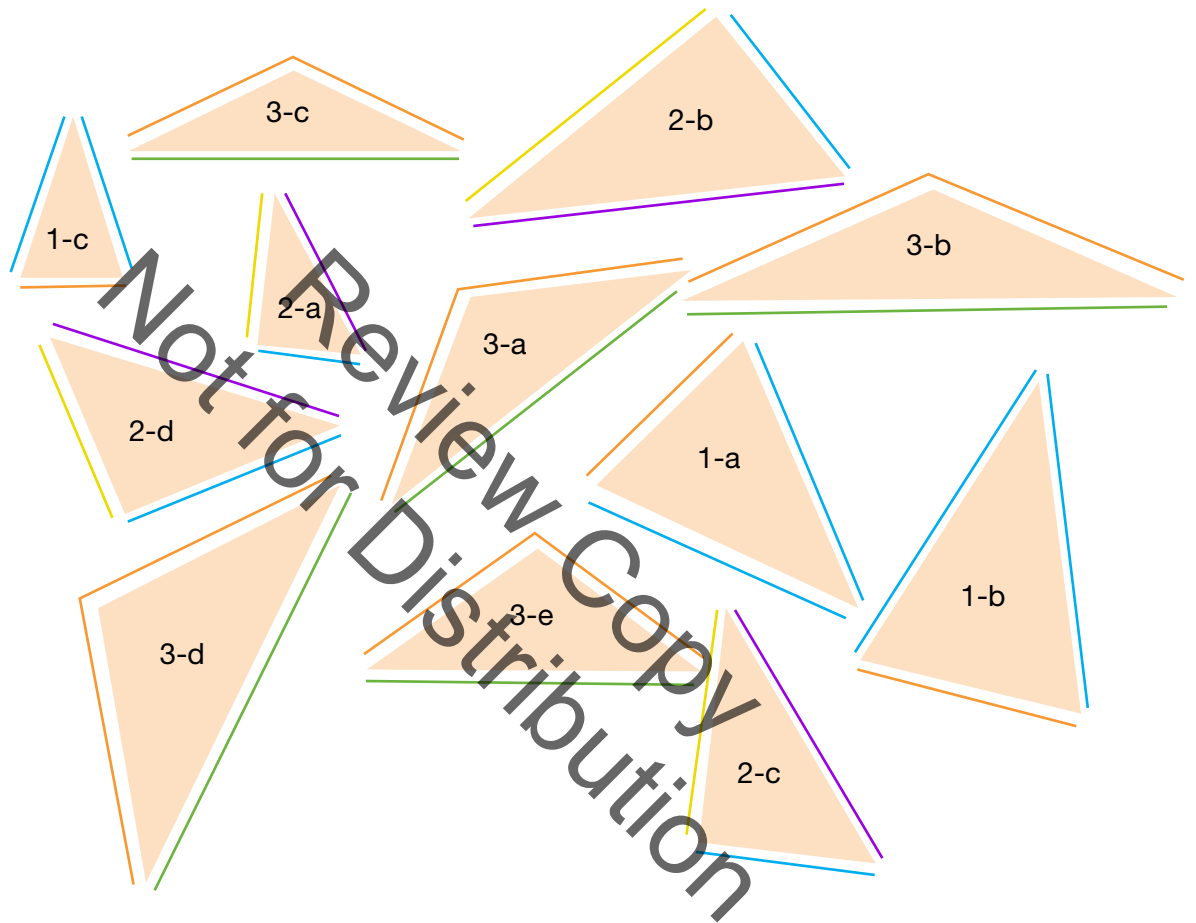

**INCLUDED IN THE STUDENT MANUAL**

**Task #19: Triangles contd.**

	Triangle 1a	Triangle 1b	Ratio of side b to side a (to the nearest cm)
Length of corresponding sides			
Length of corresponding side			
Length of corresponding side			

Ask students to measure the sides of Triangles 1a and 1b using centimeters and place their measurements in the correct location. Allow a student to fill in the table on the board. Ask the class to assess whether the student has correctly measured and labeled corresponding sides.

- What do you notice about the ratio of each of the corresponding side lengths?
- Do you think this will always happen with similar triangles?

Instruct students to work with their partner(s) to complete the tables for the Group 2 triangles.

**Task #19: Triangles contd.**

	Triangle 2a	Triangle 2b	Ratio of side b to side a (to the nearest cm)
Length of corresponding sides			
Length of corresponding side			
Length of corresponding side			

	Triangle 2c	Triangle 2d	Ratio of side b to side a (to the nearest cm)
Length of corresponding sides			
Length of corresponding side			
Length of corresponding side			



## Explanation

### PRI 3

Asking students the following questions will give students the opportunity to construct viable arguments and engage in meaningful mathematical discourse:

- Did the same pattern hold true for the triangles in Group 2 as it did for the triangles in Group 1?
- What do we call the ratio of the corresponding side lengths? (Scale factor: The ratio of any two corresponding lengths in two similar geometric figures.)
- If you know the scale factor of a similar figure and the side lengths of one triangle, how could you determine the side lengths of the similar figure? How? Explain?
- Thinking back to Lesson 6 of this unit, how do you think scale factor and proportionality are related?

## Practice Together / in Small Groups / Individually

### PRI 2

### PRI 3

In order to allow students to reason abstractly and quantitatively, collect the rulers from students. Instruct students to complete the tables using the information given and without measuring.

**Task #19: Triangles contd.**

	Triangle 3a	Triangle 3b	Ratio of side b to side a (to the nearest cm)
Length of corresponding sides	2.6 cm	3.9 cm	$\frac{3}{2}$
Length of corresponding side	2.6 cm	3.9 cm	$\frac{3}{2}$
Length of corresponding side	4.4 cm	6.6 cm	$\frac{3}{2}$

	Triangle 3c	Triangle 3d	Ratio of side d to side c (to the nearest cm)
Length of corresponding sides	2.4 cm	3 cm	$\frac{5}{4}$
Length of corresponding side	2.4 cm	3 cm	$\frac{5}{4}$
Length of corresponding side	4 cm	5 cm	$\frac{5}{4}$

Facilitate a whole-class discussion about the missing information in the tables. Asking students the following questions will give students the opportunity construct viable arguments and critique the reasoning of others:

- What strategy did you use to complete the table for Triangles 3a and 3b?
- How was your strategy for the table with Triangles 3c and 3d different?
- Why couldn't you use the exact same steps for both tables?

## Evaluate Understanding/Closing Activity

### PRI 3

Use the Think-Pair Share model to assess students' understanding of similar figures and scale factor.

Think: Have the students individually answer the following questions in their Student Manual.

#### INCLUDED IN THE STUDENT MANUAL

#### Task #20: Vocabulary

Write the definition of the following vocabulary terms in your own words.

- similar figures
- corresponding sides
- scale factor

List three things you learned about similar figures.

Pair: Instruct students to get together with the person beside or across from them and discuss their answers with each other. The students will share with each other what they think and critique their reasoning.

Share: Have different individuals or pairs share to the whole class their reasoning to each question.

**Commentary for the Teacher:** *The teacher should rotate throughout the room listening to the conversations and asking clarifying questions as necessary to correct any misunderstandings that may have occurred. When sharing, ask different groups or individuals to share different parts of the closing activity, not every part of it to save time.*

#### INCLUDED IN THE STUDENT MANUAL

#### Task #21: Lesson 7 - Exit Ticket

1. Summarize what you learned in this lesson.
2. How is this skill helpful in the real-world? Explain.
3. Would this skill have helped you in the opening activity, "Highway Robbery?" Explain.

### Independent Practice:

Students will complete Task #22: Similar Figures and Triangles activity.

INCLUDED IN THE STUDENT MANUAL

#### Task #22: Similar Figures and Triangle

Each problem can be solved using the concepts of similar triangles that you have worked on in class.

Set up the proportions and solve for the missing side of the triangle. Show your work and draw pictures if necessary to help you.

1.

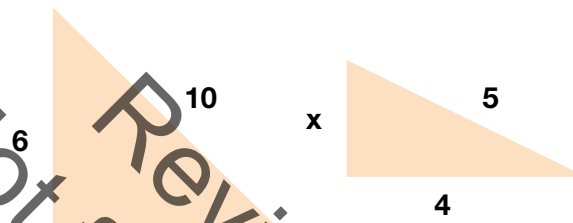

$x = \underline{6}$

2. You are standing out in front of a large tree. The sun is casting a shadow from both you and the tree. Your friend measures your shadow and records the measurements in the diagram below. Use similar triangles to determine the height of the tree.

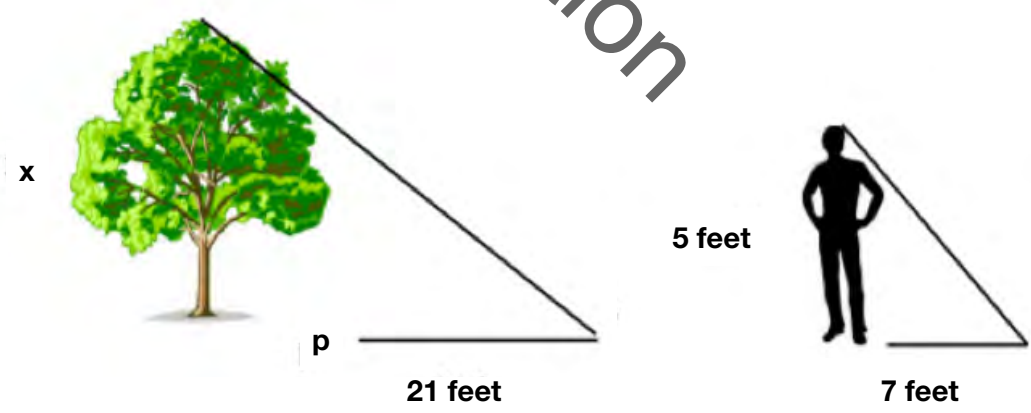

$x = \underline{15 \text{ feet}}$

3. Now it's your turn. You and a friend need to find a tree (or a flagpole or building – some tall object that is casting a shadow that you can measure). The tree or object needs to be too big for you to measure the height of it. Using the example set up in the picture above, determine the height of the object by using the shadows and the concepts of similar triangles. Illustrate your problem below, indicating recorded measurements, unknown measurements (x) and then solve the problem.

---

---

---

Height of your object \_\_\_\_\_

4. The following figures are similar. Fill in the lengths of the sides for the second figure if the scale factor is  $\frac{3}{4}$ .



### Additional Activities:

- Prior to beginning this lesson, students who need additional practice could complete an interactive activity on similar shapes found at <http://www.beaconlearningcenter.com/WebLessons/SamsSimilarShapes/default.htm>

### Resources/Instructional Materials Needed:

- Rulers
- Calculator (if needed)
- Protractor
- Task #19: Triangles
- Task #20: Vocabulary
- Task #21: Lesson 7 - Exit Ticket
- Task #22: Similar Figures and Triangles

## Ratio and Proportional Relationships

# Lesson 8 of 12

## Slope Part 1

### Description:

---

In this lesson, students will graph proportional relationships and interpret the unit rate as the slope of the line. Students will construct a function to model a linear relationship between two quantities. Students will also explore similar triangles and use them to explain why the slope is constant between any two points on a given line.

### College- and Career-Readiness Standards Addressed:

---

- EE.12 Graph proportional relationships, interpreting the unit rate as the slope of the graph. Compare two different proportional relationships represented in different ways. For example, compare a distance-time graph to a distance-time equation to determine which of two moving objects has greater speed.
- EE.13 Use similar triangles to explain why the slope  $m$  is the same between any two distinct points on a non-vertical line in the coordinate plane; derive the equation  $y = mx$  for a line through the origin and the equation  $y = mx + b$  for a line intercepting the vertical axis at  $b$ .

### Process Readiness Indicator(s) Emphasized:

---

- PRI 1: Make sense of problems and persevere in solving through reasoning and exploration
- PRI 3: Describe and justify mathematical understandings by constructing viable arguments, critiquing the reasoning of others and engaging in meaningful mathematical discourse.
- PRI 4: Contextualize mathematical ideas by connecting them to real-world situations. Model with mathematics.
- PRI 5: Use appropriate tools strategically to support thinking and problem solving.

Sequence of Instruction

Activities Checklist

Engage

*Teacher's Note: This task can be found at <https://www.illustrativemathematics.org/content-standards/8/EE/B/5/tasks/86>.*

Ask students:

- Who has ever had a sore throat?
- What are some remedies for a sore throat?

Explain to students they will examine a task today that involves two students who are sick with sore throats.

Explore

PRI 1  
PRI 4  
PRI 5

Instruct students to locate Task#23: Sore Throats, Variation 2 in their Student Manual.

INCLUDED IN THE STUDENT MANUAL

**Task #23: Sore Throats, Variation 2**

Nia and Trey both had a sore throat so their mom told them to gargle with warm salt water.

Nia mixed 1 teaspoon salt with 3 cups of water. Trey mixed  $\frac{1}{2}$  teaspoon salt with  $1\frac{1}{2}$  cups of water.

Nia tasted Trey's salt water. She said, "I added more salt so I expected that mine would be more salty, but they taste the same."

a. Explain why the salt water mixtures taste the same.

b. Find an equation that relates  $s$ , the number of teaspoons of salt, with  $w$ , the numbers of cups of water, for both of these mixtures.

c. Draw the graph of your equation from part b.

d. Your graph in part c should be a line. Interpret the slope as a unit rate.

Ask students to make sense of the problem using appropriate tools to answer the questions on the task.

Provide students tools such as rulers and graph paper as they ask for them. Allow students 10-20 minutes to complete the task with their partner. Circulate the class asking guiding questions.

### Solution: Finding equivalent ratios

- a. The ratio of the number of teaspoons of salt to the number of cups of water is 1:3 in Nia's solution. If we divide the amount of salt and the amount of water by 3, the ratio will be the same.

Thus 1:3 is equivalent to the ratio  $\frac{1}{3}$ , which means that Nia's solution has a teaspoon of salt for every cup of water. The ratio of the number of teaspoons of salt to the number of cups of water is 1:1.5 in Trey's solution. If we divide the amount of salt and the amount of water by 1.5, the ratio will be the same.

So Trey's ratio is also equivalent to the ratio  $\frac{1}{3}$ . Since each mixture has the same amount of salt for every cup of water, they are equally salty.

- b. One equation is  $s = \frac{1}{3}w$ . An equivalent equation is  $w = 3s$ .
- c. If the number of cups of water is represented on the horizontal axis, then the graph will be a line through (0,0) and (3,1). If the number of teaspoons of salt is represented on the horizontal axis, then the graph will be a line through (0,0) and (1,3).
- d. If the number of cups of water is represented on the horizontal axis, then the slope is  $\frac{1}{3}$  which means that there is  $\frac{1}{3}$  teaspoon of salt per cup of water. If the number of teaspoons of salt is represented on the horizontal axis, then the slope is 3 which means that there are 3 cups of water per teaspoon of salt.

Another way to solve the first part:

- a. Another, simpler way to solve the first part is to note that if you divide both quantities in Nia's ratio by 2, you get Trey's ratio. You will still have to interpret the unit rate for the other parts of the task.

## Explanation

Facilitate a whole-class discussion about the answers to the task. Ask different pairs of students to share their responses. Ask the rest of the class to agree or disagree with the explanations and expand on what other students have said.

When the discussion turns to part d, discuss with students why the slope can be interpreted as the unit rate for the problem. Ask students to draw one right triangle for each mixture. Each triangle should connect the origin to the mixture point. The triangles should look like this picture.

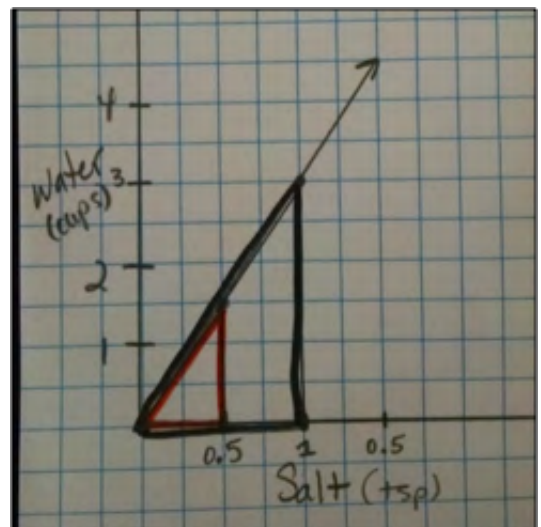

Ask students:

- What types of triangles are these? (similar triangles)
- How do you know these are similar triangles? (Two of their angles are congruent and all three sets of corresponding sides are proportional.)

Discuss with students how using similar triangles can help us see why the slope  $m$  is the same between any two distinct points on a non-vertical line in the coordinate plane.

### Practice Together / in Small Groups / Individually

Ask students to locate Task #24: Who Has the Best Job? in their Student Manual. This task can also be found at <https://www.illustrativemathematics.org/content-standards/8/EE/B/5/tasks/184>

Students can complete this task with their partner or individually.

INCLUDED IN THE STUDENT MANUAL

#### Task #24: Who Has the Best Job?

Kell works at an after-school program at an elementary school. The table below shows how much money he earned every day last week.

Time worked	1.5 hours	2.5 hours	4 hours
Money earned	\$12.60	\$21.00	\$33.60

Mariko has a job mowing lawns that pays \$7 per hour.

- Who would make more money for working 10 hours? Explain or show work.
- Draw a graph that represents, the amount of money Kell would make for working hours, assuming he made the same hourly rate he was making last week.
- Using the same coordinate axes, draw a graph that represents, the amount of money Mariko would make for working hours.
- How can you see who makes more per hour just by looking at the graphs? Explain.

---

---



**Solution**

a. Mariko would make  $7 \times 10 = 70$  dollars for working 10 hours. Kell's hourly rate can be found by dividing the money earned by the hours worked each day.

Time worked	1.5 hours	2.5 hours	4 hours
Money earned	\$12.60	\$21.00	\$33.60
Pay rate	\$8.40per/hr	\$8.40 per/hr	\$8.40 per/hr

If Kell works for 10 hours at this same rate, he will earn  $8.4 \times 10 = 84$  dollars. So Kell will earn more money for working 10 hours.

Alternatively, we could reason proportionally without computing the unit rate.

b. You can see that Kell will make more per hour if you look at the points on the graph where  $X = 1$  since this will tell you how much money each person will make for working 1 hour. You can also compare the slopes of the two graphs, which are equal to the hourly rates. See the figure below.

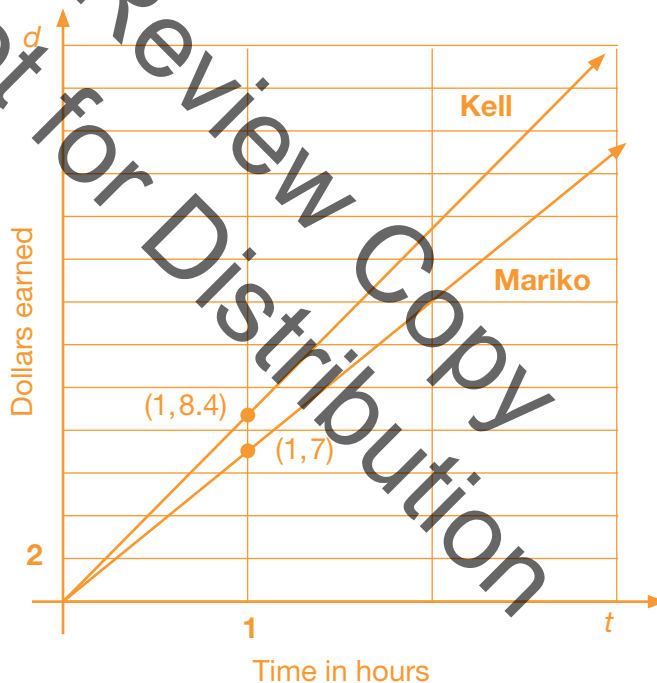

**Evaluate Understanding**

**PRI 3**

Evaluate students' understanding based on the explanations to their partners. Facilitate a whole-group discussion about the answers to Task #24: Who Has the Best Job. Ask different pairs of students to share their responses.

**Closing Activity**

On a sheet of paper, write the unit rate for Kell and Mariko and explain how to determine the unit rate by looking at the graph.

### Independent Practice:

Task #25: Stuffing Envelopes which can be found in the Student Manual and at <https://www.illustrativemathematics.org/content-standards/8/EE/B/5/tasks/1552>

INCLUDED IN THE STUDENT MANUAL

#### Task #25: Stuffing Envelopes

Anna and Jason have summer jobs stuffing envelopes for two different companies. Anna earns \$14 for every 400 envelopes that she finishes. Jason earns \$9 for every 300 envelopes that he finishes.

- a. Draw graphs and write equations that show the earnings,  $y$  as functions of the number of envelopes stuffed,  $n$  for Anna and Jason.
- b. Who makes more from stuffing the same number of envelopes? How can you tell this from the graph?

---

---

---

- c. Suppose Anna has savings of \$100 at the beginning of the summer and she saves all her earnings from her job. Graph her savings as a function of the number of envelopes she stuffed,  $n$ .

How does this graph compare to her previous earnings graph? What is the meaning of the the slope in each case?

---

---

---

Solution:

The amount of money earned,  $y$ , and the number of envelopes stuffed,  $n$ , are proportional to each other. Since Anna earns \$14 for 400 envelope, she makes  $14/400 = 0.035$  dollars per envelope. Therefore, we have  $y = 0.035n$  for Anna's equation.

Jason earns \$9 for every 300 envelopes he stuffs, so he makes  $9/300 = 0.03$  dollars per envelope. So we have  $y = 0.03n$  for Jason's equation.

Since Anna's equation has a larger unit rate, 0.035 dollars per envelope vs. 0.03 dollars per envelope for Jason, she has the higher paying job.

We know that we can find the unit rate of proportional relationships by finding the point on the line with horizontal coordinate 1.

For every envelope they stuff, Anna makes half a cent more than Jason. Since Anna makes more money per envelope, her earnings increase faster than Jason's. Therefore, her earnings line is steeper than Jason's.

Anna still earns money at the same rate as before, but now her earnings are added to her savings of \$100. The graph showing her total savings, including the money she earns, is still linear but it has a higher starting value. The new line is parallel to the previous earnings line but while the previous line went through the point (0,0), the new line starts at the point (0,100). This shows that when she starts working she already has \$100 in savings.

For her earnings graph, we see that she will make \$0.035 for every envelope she stuffs, but for her savings, she will save an *additional* \$0.035 for every *additional* envelope she stuffs.

### Reflection:

INCLUDED IN THE STUDENT MANUAL

#### Task #26: Lesson 8 - Exit Ticket

1. Summarize what you learned in this lesson.
2. How is this skill helpful in the real-world? Explain.
3. Would this skill have helped you in the opening activity, "Highway Robbery?" Explain.

### Extension:

Extend this lesson to include using slope in similar triangles by the adding the Illumination Activity listed below. This activity will tie back into the similar triangle lesson that the students have previously completed. They are asked to count the slope, using the graphs. <http://illuminations.nctm.org/Lesson.aspx?id=2570>

### Resources:

- Task #23: Sore Throats, Variation 2
- Task #24: Who Has the Best Job?
- Task #25: Stuffing Envelopes
- Task #26: Lesson 8 - Exit Ticket

## Ratio and Proportional Relationships

# Lesson 9 of 12

## Slope Part 2

*(optional: Depending on student's background, you may want to wait until Unit 6 to include this lesson)*

### Description:

---

Students will examine slope and y-intercept within the context of a real-world problem. They will write and graph a linear equation given two points on a line and discuss what it means for a function to be linear.

### College- and Career-Readiness Standards Addressed:

---

- EE.12 Graph proportional relationships, interpreting the unit rate as the slope of the graph. Compare two different proportional relationships represented in different ways. For example, compare a distance-time graph to a distance-time equation to determine which of two moving objects has greater speed.

### Process Readiness Indicator(s) Emphasized:

---

- PRI 4: Contextualize mathematical ideas by connecting them to real-world situations. Model with mathematics.
- PRI 5: Use appropriate tools strategically to support thinking and problem solving.
- PRI 6: Attend to precision.
- PRI 7: Look for and make use of patterns and structure.
- PRI 8: Look for and express regularity in repeated reasoning.

Sequence of  
Instruction

Activities Checklist

Explore

**PRI 4**  
**PRI 7**  
**PRI 8**

Explain to the students they are going to determine how much Domino's is really charging for their pizza. Play the video found at <http://www.mathalicious.com/lessons/domino-effect/teach>.

*Teacher's Note: This video shows someone ordering a two-topping medium pizza online from Domino's in Washington, DC, and find out that it costs \$13.97 before tax. This lesson is adapted from the website <http://www.uen.org/Lessonplan/preview.cgi?LPid=20100>.*

Ask students how much they think Domino's charges for toppings for a medium pizza. The students should make use of repeated reasoning and find various patterns within the topping problem.

Chart students' responses on the board. Some possible responses might be:

- Since a 2-topping pizza costs \$13.97, each topping must cost  $\$13.97 \div 2$  toppings = \$6.99/topping.
- Other students might realize that this is unreasonable; not only does this seem absurdly expensive, but they may know that the pizza also includes a base price.

To prompt students' thinking, ask guiding questions about the relationship between the cost per topping and the base price. The purpose of this and the discussion is to get the students to realize they need more information in order to determine the cost of a medium pizza with toppings at Domino's. Some guiding questions might be:

- What else do you think Domino's charges for besides the toppings?
- What other information would you need to determine the cost?

Explore

**PRI 7**  
**PRI 8**

Explain students will work in groups of 2-3 to complete the following tasks. Instruct students to locate Task #27: Act 1, Meaty Yum in the Student Manual. They will complete Act One with their partner.

*Teacher's Note: Working in pairs will allow the students to build on each other's knowledge and gain a deeper understanding of the mathematical patterns and relationships that they are seeking. The students will need to think strategically with the various tasks in order to effectively problem solve.*



Allow students 10-15 minutes to explore this task.

INCLUDED IN THE STUDENT MANUAL

### Task #27: Act One: Meaty Yum

#### Act One: Meaty Yum

- 1 Below are prices for a medium 2-topping pizza and a medium 4-topping pizza from Domino's in Washington, DC. Plot them on your graph and use the information to answer the following questions.

ITEM	PRICE	ITEM	PRICE
 Medium (12") Hand Tossed Pizza Whole: Pepperoni, Green Peppers	\$13.97	 Medium (12") Hand Tossed Pizza Whole: Bacon, Premium Chicken, Green Peppers, Mushrooms	\$16.95

- a. Based on the information above, how much do you think Domino's is charging for each topping?
- b. A medium 3-topping pizza costs \$15.46. What would it mean if it cost *more* than this, e.g. \$16?

*For two additional toppings, you pay an additional \$16.95 - \$13.97 = \$2.98. Therefore, each topping costs \$2.98 ÷ 2 = \$1.49.*

*If a 2-topping pizza costs \$13.97, we'd expect a 3-topping pizza to cost \$13.97 + \$1.49 = \$15.46.*

*If it cost more than this, though, it would mean that Domino's wasn't charging a constant \$1.49 per additional topping, since the fourth topping would cost less than the third.*

- c. For the 2-topping pizza, how much in total are you spending on toppings? For the 4-topping pizza?
- d. If you wanted to order a medium cheese pizza, how much would you expect to spend? Explain.

*For 2 toppings: \$1.49(2) = \$2.98 on toppings  
 For 4 toppings: \$1.49(4) = \$5.96 on toppings*

*A two topping pizza costs \$13.97. Since \$2.98 of that is spent on toppings, the base price of a plain cheese pizza must be \$13.97 - \$2.98 = \$10.99.*

*The same result could be calculated by using a 3 or 4-topping pizza.*

- e. Now write an equation for the price of a medium pizza, and explain what the equation means.
- f. Does a pizza with 12 toppings cost twice as much as a pizza with 6 toppings? Why or why not?

*Let C = price of pizza and t = number of toppings*

$$C = 10.99 + 1.49t$$

*What this equation means is that, for a medium pizza, Domino's is charging a \$10.99 base price plus \$1.49 for each topping.*

*6 topping pizza: \$10.99 + \$1.49(6) = \$19.93  
 12 topping pizza: \$10.99 + \$1.49(12) = \$28.87*

*The 12-topping pizza isn't twice as expensive. The reason is because you don't double the base price; you only double the amount that you're spending on the toppings.*

### Explanation

#### PRI 6

Facilitate a whole-group discussion about the answers to Act One. Select several groups to share their work.

*Teacher's Note: Students should come to the conclusion they need to find the unit rate for cost per topping. They should determine how much is the cost per pizza increasing when more toppings are added. A reasonable answer is that the price of the pizza is*

increasing by \$2.98 per two toppings, so the unit rate would be  $\$2.98 \div 2 = \$1.49$ . This is a time to bring in the vocabulary that the rate of change is the slope. The rate of change is the slope because it determines how fast the graph is growing or declining. For this case, the rate of change, or slope, is \$1.49 per topping. It is important for the students to be precise with the vocabulary and the labeling of rates.





**Practice Together / in Small Groups / Individually**

Instruct students to locate Task #28: Act Two: Pizza Tracker in their Student Manual. Explain students will work with their partner(s) to analyze the cost of small and large pizzas. They will determine the cost per topping for each size pizza and then write an equation for each small and large pizza.

INCLUDED IN THE STUDENT MANUAL

**Task #28: Act Two: Pizza Tracker**

2 Below are the prices for two small pizzas and two large pizzas from Domino's. Write an equation to calculate the cost of each size based on the number of toppings you order.

ITEM	PRICE	ITEM	PRICE
 Small (10") Hand Tossed Pizza Whole: Pepperoni	\$9.99	 Large (14") Hand Tossed Pizza Whole: Sliced Italian Sausage, Green Peppers, Roasted Red Peppers, Mushrooms	\$19.75
 Small (10") Hand Tossed Pizza Whole: Premium Chicken, Black Olives, Jalapeno Peppers	\$11.99	 Large (14") Hand Tossed Pizza Whole: Philly Steak	\$14.68

3 Now graph the equation for each pizza size, and answer the following:

<p>a. Which graph – small, medium, or large – is the steepest, and why do you think this is?</p>	<p>b. Which graph has the lowest starting value, and is this what you'd expect? Explain.</p>
--	--

4 Look at the graph of how much Domino's really charges for pizza in Washington, DC. How is the actual situation different than what you expected...and why do you think Domino's does this?

## DOMINO EFFECT

How much does Domino's charge for pizza?



name \_\_\_\_\_

date \_\_\_\_\_



### Act One: Meaty Yum

- 1 Below are prices for a medium 2-topping pizza and a medium 4-topping pizza from Domino's in Washington, DC. Plot them on your graph and use the information to answer the following questions.

ITEM	PRICE	ITEM	PRICE
 Medium (12") Hand Tossed Pizza Whole: Pepperoni, Green Peppers	\$13.97	 Medium (12") Hand Tossed Pizza Whole: Bacon, Premium Chicken, Green Peppers, Mushrooms	\$16.95

a. Based on the information above, how much do you think Domino's is charging for each topping?	b. A medium 3-topping pizza costs \$15.46. What would it mean if it cost <i>more</i> than this, e.g. \$16?
c. For the 2-topping pizza, how much in total are you spending on toppings? For the 4-topping pizza?	d. If you wanted to order a medium cheese pizza, how much would you expect to spend? Explain.
e. Now write an equation for the price of a medium pizza, and explain what the equation means.	f. Does a pizza with 12 toppings cost twice as much as a pizza with 6 toppings? Why or why not?

Not for Review Copy Distribution

#### Explanation & Guiding Questions

Following Act One, students – particularly those on autopilot – might incorrectly assume that Domino's is charging the same amount for a small and large topping as they are for a medium: \$1.49. If so, ask them whether \$1.49 will get them from \$9.99 (small 1-topping) to \$11.99 (small 3-topping). It won't. Instead, they must calculate the cost per topping from scratch...pardon the pun! With the small pizza, two more toppings cause the price to increase by \$2, which clearly suggests that Domino's isn't charging \$1.49 per small topping, but rather \$1.

Once they have the cost per topping for the small and large pizzas, students can use the same process as before to determine the total spent on toppings, the base price, and the equation for each size.

- Does Domino's charge \$1.49 per topping for the small and large pizzas? How can we check this?
- For each pizza, how much are we spending on toppings? Based on this, what must the base price be?

#### Deeper Understanding

- Which size pizza has the highest cost per topping, and why? (Large, because we get the most topping.)
- Which size pizza has the lowest base price, and why? (Small, because we get the least amount of pizza.)



*Teacher's Note: Students should know that a linear equation can be written in the form  $y=mx+b$ . You might need to revisit this with the students before they complete this part of the task. Ask students to recall the different parts of the linear equation and what they represent.  $m$ = rate of change and  $b$ = the  $y$ -intercept. Ask students to also recall that the rate of change is equal to the change in  $y$  divided by the change in  $x$ . To find the rate of change between two points, an appropriate formula would be*

$$\frac{y_2 - y_1}{x_2 - x_1}$$

Circulate the classroom as students are working. Once groups have determined the cost per topping for the small and large pizzas, encourage students to discuss what the base price is for each size. Students will look for and make use of patterns while expressing regularity in repeated reasoning. Ask questions such as:

- Does Domino's charge \$1.49 per topping for the small and large pizzas? How did your group determine if they did or didn't?
- Based on the price per toppings, how much is the base price of each size pizza?
- Is it the same for a small and large?
- Which pizza has the the highest/lowest cost per topping, and why do you think that is?

When students get to problem 3, they will be asked to graph the equations they created on the same coordinate plane and answer the questions:

- Which graph – small, medium, or large – is the steepest, and why do you think this is?
- Which graph has the lowest starting value, and is this what you'd expect?

When discussing the steepness of the graph with the students, ask them to explain what they think the steepness of these graphs represent. In this problem, the steepness (slope/rate of change) is how much the cost is per topping. Students should see that the graph is rising faster with the large pizza because the cost per topping is more than with the small or medium pizzas. Also ask students to explain what the starting value on the graph represents.

## Evaluate

---

Once the students have completed their graphs, bring the class back together to reveal the actual graphs describing how Dominos charges. The students should see that no matter the size, Domino's stops charging after the fourth topping and they also don't allow the customer to order more than 10 toppings. This will allow for a class discussion about possible reasons for Domino's pricing model.

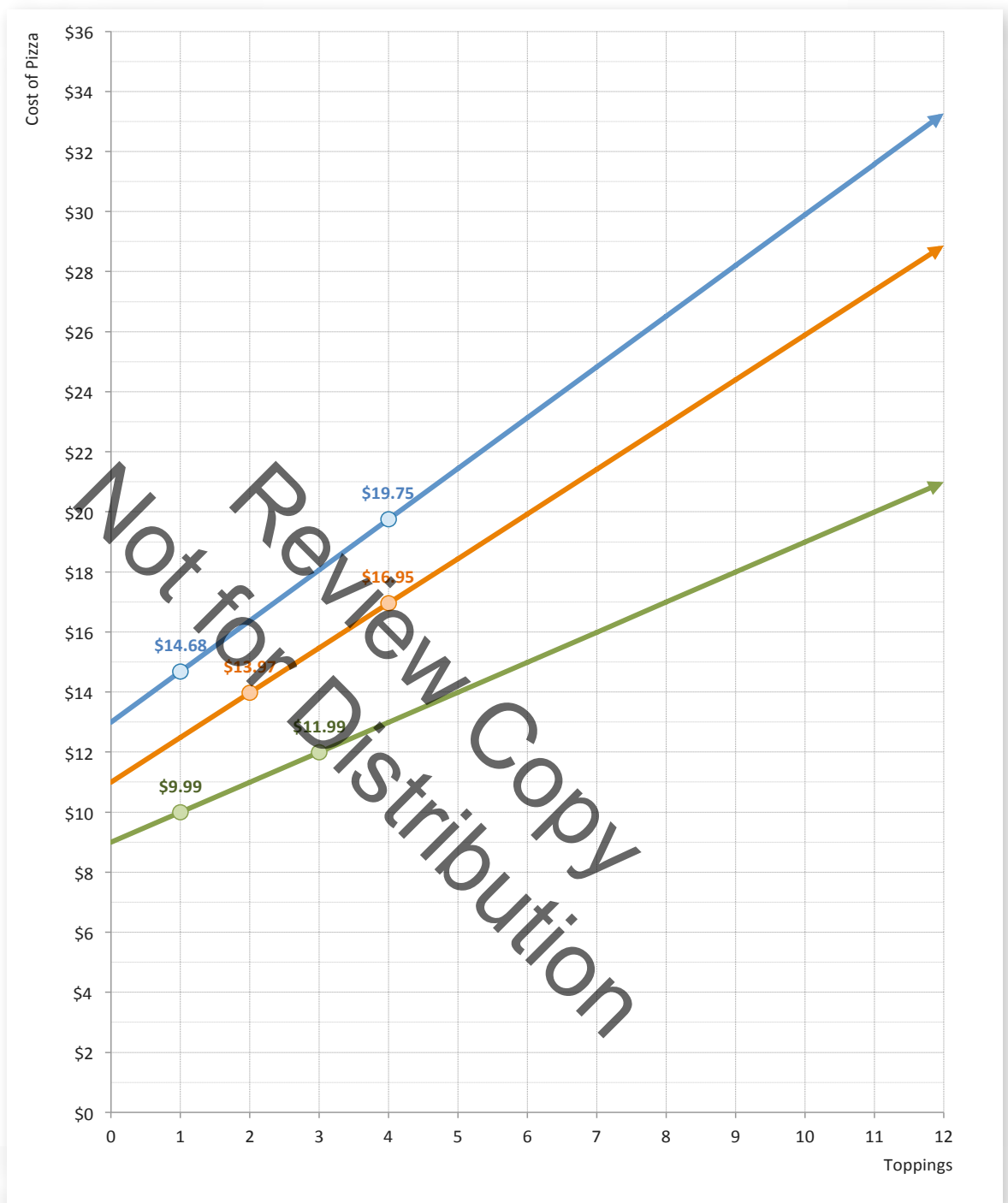

Facilitate a whole-class discussion. Ask the students:

- Why did each equation/relationship that was graphed create a line?
- What word do we use to describe graphs that form straight lines? (linear)
- What makes these particular graphs linear?
- What is the cost of each topping?
- What is the base price for a plain pizza with no toppings?
- What do we call the base price, or where the equation or graph starts? (y-intercept)

## Closing Activity

Allow students to reflect on the following questions:

The 4-topping pizza includes “premium chicken.” Does Domino’s charge more for premium toppings? (No.)

- Domino’s charges a constant \$1.49 per topping. Do all pizza places do this? (Probably not.)
- When we graph the price of a medium pizza, should we draw a solid line? (Since we can’t order, say, 1.4 toppings, it might make more sense just to plot the points. However, modeling with a line is very useful in visualizing the relationship between the cost of a pizza and the number of toppings, as long as students understand that the line isn’t necessarily an accurate representation of reality.)
- Actually, should we even call it a “line?” (Probably not. Since we can’t order negative toppings, we’re restricted to positive values of  $x$ . Thus, we’re not actually drawing a line but rather a ray.)
- We know how the graphs are different, but how are they alike? (They’re all lines, which means that Domino’s is charging a constant amount for each pizza size...even though the amount is different.)
- If we were drawing a line rather than a ray – i.e. if the situation allowed for negative values of  $x$  – would it make sense to talk about a “starting value?” (No. A line is infinitely long, which means it has no start!)

INCLUDED IN THE STUDENT MANUAL

### Task #29: Lesson 9 - Exit Ticket

1. Summarize what you learned in this lesson.
2. How is this skill helpful in the real-world? Explain.
3. Would this skill have helped you in the opening activity, “Highway Robbery?” Explain.

## Resources/Instructional Materials Needed:

- “Domino’s Effect” video <http://www.mathalicious.com/lessons/domino-effect/teach>
- Task #27: Act One: Meaty Yum
- Task #28: Act Two: Pizza Tracker
- Task #29: Lesson 9 - Exit Ticket

## Extension:

How do other pizza chains charge for their pizzas? In this extension activity, students examine two other pizza chains and see how their costs compare to Domino’s. Students will work in groups to research two other major pizza chains of their choice. They will need to determine the cost per topping for a small, medium and large for each of the chains. Then they will need to determine the base price for each size pizza. Once they have done that for each chain, they will then write an equation and graph each company on one graph. Then they will need to create a presentation of their choice to present to the class their findings.

## Ratio and Proportional Relationships

# Lesson 10 of 12

## Scaling

### Description:

---

This lesson will explore scale models and scale drawings. Scale factors are discussed. Students will solve problems involving scale drawings of geometric figures, including computing actual lengths and areas from a scale drawing and reproducing a scale drawing at a different scale.

### College- and Career-Readiness Standards Addressed:

---

- G.1 Solve problems involving scale drawings of geometric figures, including computing actual lengths and areas from a scale drawing and reproducing a scale drawing at a different scale.
- EE.12 Understand the connections between proportional relationships, lines, and linear equations.

### Process Readiness Indicator(s) Emphasized:

---

- PRI 1: Make sense of problems and persevere in solving through reasoning and exploration
- PRI 6: Attend to precision.
- PRI 10: Reflect on mistakes and misconceptions to improve mathematical understanding.

Sequence of  
Instruction

Activities Checklist

Engage

Show the video “Math Snacks – Scale Ella” found at [https://www.youtube.com/watch?v=0JCoSeFKW\\_Y](https://www.youtube.com/watch?v=0JCoSeFKW_Y).

If you are unable to access content via YouTube, the video (in English and Spanish) may also be found at <http://mathsnacks.com/media/animations/scaleella.m4v> (English) or [http://mathsnacks.com/media/animations/scaleella\\_sp.m4v](http://mathsnacks.com/media/animations/scaleella_sp.m4v) (Spanish).

Ask students the following questions:

1. What are some of the math vocabulary words you heard in the animation? (Write them on board.)
2. What do you think “scale factor” means? (Remind students to think back to Lesson 7 on similar triangles.)
3. When Scaleo and Scale Ella were making something larger, what were some of the scale factors? What do they have in common? (*3. They were bigger than 1.*)
4. When they were making something smaller, what were some of the scale factors? What do they have in common? (*1/3. They are fractions.*)
5. So if I want to scale something up, what should the scale factor be? (*Bigger than 1.*)
6. If I want to scale something down, what should the scale factor be? (*Between 0 and 1. Teacher’s Note: It is important that students understand these concepts. Sometimes students will want to scale down using a negative number or subtraction instead of division and multiplication.*)
7. What operations were they using to scale something up or down? (*Multiplication and division*)
8. Why would you never subtract or add if you are scaling? (*Adding or subtracting will change the proportion. The ratio of the numbers is not the same when adding or subtracting.*)
9. What did Scale Ella have to do to compute the scale factor when the units of measure were different? (*She had to convert the units so they were the same.*)

### Explore

**PRI 1**  
**PRI 6**

Instruct students to locate Task #30: Scale Ella in their Student Manuals. Group students in “similar-ability” pairs. Instruct them to make sense of the problem and complete the task with their partner.

INCLUDED IN THE STUDENT MANUAL

#### Task #30: Scale Ella



## Scale Ella

### Learner Guide



Watch the animation, *Scale Ella*, and complete these activities. The animation and an instructor guide are available on iTunes U (search “Math Snacks”) and at [mathsnacks.org](http://mathsnacks.org)

The regular size of a twin bed is 39” wide, 75” long and 24” high. Scaleo has scaled your bed to this size: 13” wide, 25” long and 8” high.

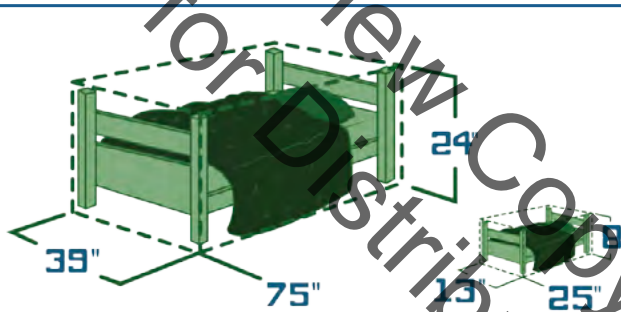

**1. What can Scale Ella do so that you can sleep comfortably tonight?**

---

---

---

---

---

---

---

---

**2. Scaleo has now scaled you to be bigger by a scale factor of 7. What is your new height?**

$$\square \times 7 = \square$$

Your Height  $\times$  Scale Factor = Your New Height

**A. Will you fit on a regular-sized bed?**

---

---

---

---

---



**B. If you can't, what can Scale Ella do to help you?**

---

---

---

---

---

3. You have been given Scale Ella's powers, but before you scale items you have to practice by scaling numbers. Pick a scale factor that will increase the numbers and enter it into box 1. Pick a scale factor that will decrease the numbers and enter it into box 2. Once you pick your scale factors, complete the table by applying the scale factors to increase and decrease the numbers.



	Scale Up By	Scale Down By
Numbers	1 <input type="text"/>	2 <input type="text"/>
.05	<input type="text"/>	<input type="text"/>
1/2	<input type="text"/>	<input type="text"/>
7	<input type="text"/>	<input type="text"/>
13	<input type="text"/>	<input type="text"/>
25	<input type="text"/>	<input type="text"/>
102	<input type="text"/>	<input type="text"/>

4. If you could scale **up** three things in your life by a factor of 5,

A. What would you scale up? Why?

	<hr/> <hr/>
	<hr/> <hr/>
	<hr/> <hr/>

5. If you could scale **down** three things in your life by a factor of  $\frac{1}{5}$ ,

B. What would you scale down? Why?

	<hr/> <hr/>
	<hr/> <hr/>
	<hr/> <hr/>



© 2012, NMSU Board of Regents. NMSU is an equal opportunity/affirmative action employer and educator. "Math Snacks" materials were developed with support from the National Science Foundation (0918794). Any opinions, findings, and conclusions or recommendations expressed in this material are those of the author(s) and do not necessarily reflect the views of the National Science Foundation.

Circulate the classroom as pairs work together, asking guiding questions. Encourage students to attend to precision in their calculations. Allow 15-25 minutes for students to complete the task. Facilitate a whole-group discussion about students' responses to the items on the task.

## Explanation

---

A scale model is a proportional model of a three-dimensional object. Its dimensions are related to the dimensions of the actual object by a ratio called the scale factor. A scale is the ratio between two sets of measurements. Scales can use the same units or different units. A scale drawing is a proportional drawing of an object. Both scale drawings and scale models can be smaller or larger than the objects they represent.

## Practice Together / in Small Groups / Individually

---

The following activity can be done in groups of two or three students or individually. If you choose to have the students complete the activity individually, you may choose to use a second picture from “Scale Ella” and make two large groups. Another option is to separate the students into two large groups and give both groups the same picture to recreate. In this scenario, the large groups compete to have the most accurate scaled-up version.

### Directions

1. Cut out the puzzle of Scaleo provided below into 12 different rectangles.
2. Divide students into 12 groups. (Note: If the number of students in the class does not lend itself to 12 groups, the puzzle can be cut into any number of pieces. The ideal group size is two to three students.)
3. Give each group a piece of graph paper, a ruler, a pencil and colored pencils.
4. Give each group one puzzle piece.
5. Have the class choose a whole number scale factor to make the puzzle bigger. The scale factor should be between 2 and 7. Have the students also pick a scale factor to make the puzzle smaller. Encourage students to choose a benchmark fraction like  $\frac{1}{4}$ ,  $\frac{1}{2}$ , or  $\frac{1}{3}$ . All groups will use the same scale factors.
6. Have students scale their puzzle piece using the scale factors selected. Give them a hint: They can scale the rectangle first and then focus on the details within the puzzle piece itself. They will create two similar versions of the assigned puzzle piece – one larger than the original picture and one smaller.
7. Have students draw their scaled puzzle pieces using pencil and then color them in using the colored pencils. Ask students to use the same colors as on the original picture.
8. When everyone is done with their puzzle pieces, have them put the puzzles together on the board. Students can come up to the board one piece at a time.
9. The result should be a scaled-up version and a scaled-down version of the original puzzle.

Scaleo is 3 by 4 inches and can be cut into 12 pieces.





### Evaluate Understanding

Ask students to evaluate their own work on the pictures during the Closing Activity.

### Closing Activity

#### PRI 10

Ask students to evaluate their own work on the pictures.

- How well did you create scaled-up and scaled-down versions of your puzzle pieces?
- How could you improve your drawings?
- What have you learned today about scale factor and scale drawings?

What are you still struggling with that was in this lesson today?

### Reflection/Exit Slip:

INCLUDED IN THE STUDENT MANUAL

#### Task #31: Lesson 10 - Exit Ticket

1. Summarize what you learned in this lesson.
2. How is this skill helpful in the real-world? Explain.
3. Would this skill have helped you in the opening activity, "Highway Robbery?" Explain.

### Independent Practice:

Task #32: Growing Rectangles, which can be found in the Student Manual and at <http://nrich.maths.org/6923&part=>

INCLUDED IN THE STUDENT MANUAL

### Task #32: Growing Rectangles

Imagine a rectangle with an area of  $20\text{cm}^2$

What could its length and width be?

---

List at least five different combinations.

---

---

---

---

---

Imagine enlarging each of your rectangles by a scale factor of 2:



List the dimensions of your enlarged rectangles and work out their areas.

What do you notice? *(multiplied by 4)*

Try starting with rectangles with a different area and enlarge them by a scale factor of 2.

What happens now? *(multiplied by 4)*

Can you explain what's going on?

What happens to the area of a rectangle if you enlarge it by a scale factor of 3?  
*(multiply by 9) Or 4? (16) Or 5 ...? (25)*

What happens to the area of a rectangle if you enlarge it by a fractional scale factor?  
*(For any scale factor, you square it and then multiply that new number by the original area.)*

What happens to the area of a rectangle if you enlarge it by a scale factor of  $k$ ? *(If you increase a rectangle by a scale factor  $k$ , the area of the new rectangle will be  $k^2$  times the old area of the rectangle.)*

Explain and justify any conclusions you come to. *(You square the scale factor to find out how much bigger the areas have become.)*

Do they apply to plane shapes other than rectangles? *(this rule applies to all plane shapes because when different rectangles and triangles are increased by different scale factors, the increase in area is the same.)*



Now explore what happens to the surface area and volume of different cuboids when they are enlarged by different scale factors.

Explain and justify any conclusions you come to. *(with rectangles and cuboids, whatever the scale factor is: you square the scale factor and then multiply that number by the old area to find the new area (two measurements), and you cube the scale factor and times that number by the old volume (three measurements) to find the new volume.)*

Explain and justify any conclusions you come to. with rectangles and cuboids, whatever the scale factor is: you square the scale factor and then multiply that number by the old area to find the new area (two measurements), and you cube the scale factor and times that number by the old volume (three measurements) to find the new volume.

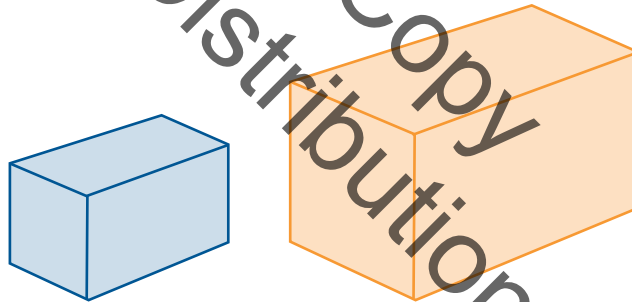

Do your conclusions apply to solids other than cuboids? *(yes)*

### Resources/Instructional Materials Needed:

- [https://www.youtube.com/watch?v=0JCoSeFKW\\_Y](https://www.youtube.com/watch?v=0JCoSeFKW_Y)
- <http://nrich.maths.org/6923&part=>
- Pictures of Scaleo
- Colored pencils
- Copy paper
- Task #30: Scale Ella
- Task #31: Lesson 10 - Exit Ticket
- Task #32: Growing Rectangles

### Additional Activities:

---

- If available, students will enjoy reading, or having read to them, *If You Hopped Like a Frog* by David Schwartz and/or the poem “One Inch Tall” in *Where the Sidewalk Ends*, Silverstein
- A good project for students to work together or individually can be found at <http://www.opusmath.com/common-core-standards/7.g.1-solve-problems-involving-scale-drawings-of-geometric-figures-including>

Review Copy  
Not for Distribution

## Ratio and Proportional Relationships

# Lesson 11 of 12

## Formative Assessment Lesson: Drawing to Scale: Designing a Garden

### Description:

---

This lesson is intended to help assess how well students are able to interpret and use scale drawings to plan a garden layout. This involves using proportional reasoning and metric units.

### College- and Career-Readiness Standards Addressed:

---

- RP Analyze proportional relationships and use them to solve real-world and mathematical problems.
- G Draw, construct, and describe geometrical figures and describe the relationships between them. Solve real-life and mathematical problems involving angle measure, area, surface area, and volume.
- EE Solve real-life and mathematical problems using numerical expressions.

### Process Readiness Indicator(s) Emphasized

---

- PRI 1: Make sense of problems and persevere in solving through reasoning and exploration
- PRI 2: Reason abstractly and quantitatively by using multiple forms of representations to make sense of and understand mathematics.
- PRI 3: Describe and justify mathematical understandings by constructing viable arguments, critiquing the reasoning of others and engaging in meaningful mathematical discourse.
- PRI 4: Contextualize mathematical ideas by connecting them to real-world situations. Model with mathematics.
- PRI 5: Use appropriate tools strategically to support thinking and problem solving.
- PRI 6: Attend to precision.
- PRI 8: Look for and express regularity in repeated reasoning.
- PRI 9: Demonstrate flexible use of strategies and methods while reflecting on which procedures seem to work best for specific types of problems.
- PRI 10: Reflect on mistakes and misconceptions to improve mathematical understanding.

Students will engage in the Formative Assessment Lesson: Drawing to Scale: Designing a Garden, which can be found at: <http://map.mathshell.org/download.php?fileid=1641>

The following *Formative Assessment Lesson* is a classroom-ready lesson included to help teachers assess and improve students' understanding of mathematical concepts and skills and their ability to use the mathematical process readiness indicators critical for college readiness.

Research has shown that formative assessment, as embodied in the following lesson, is a powerful way to improve student learning and performance. This approach first allows students to demonstrate their prior understandings and abilities in employing the mathematical processes, and then resolve their own difficulties and misconceptions through structured discussion. This results in more secure long-term learning, reducing the need for re-teaching that otherwise takes so much classroom time.

Many often ask, why don't students just remember the procedures they have been taught and practiced? The fact is, that approach works fine in the short term but, as every teacher knows, if procedural knowledge is not underpinned by conceptual understanding, students will quickly forget "how to do it."

Read more about the *Formative Assessment Lesson* rationale, structure, and philosophy using the *Brief Guide for Teachers and Administrators* that can be found at <http://map.mathshell.org/materials/index.php>.

Review Copy  
Not for Distribution

---

**PROBLEM SOLVING**

---

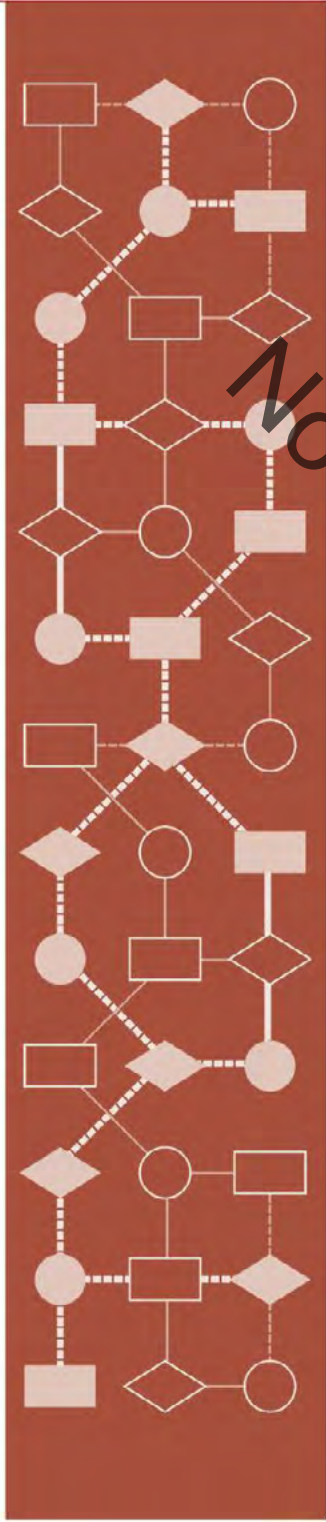

Mathematics Assessment Project  
**CLASSROOM CHALLENGES**  
A Formative Assessment Lesson

**Drawing to Scale:  
A Garden**

Not for Review Copy  
for Distribution

Mathematics Assessment Resource Service  
University of Nottingham & UC Berkeley

For more details, visit: <http://map.mathshell.org>  
© 2015 MARS, Shell Center, University of Nottingham  
May be reproduced, unmodified, for non-commercial purposes under the Creative Commons license  
detailed at <http://creativecommons.org/licenses/by-nc-nd/3.0/> - all other rights reserved

## BEFORE THE LESSON

### Assessment task: *Design a Garden* (20 minutes)

Have students complete this task, in class or for homework, a few days before the formative assessment lesson. This will give you an opportunity to assess the work and to find out the kinds of difficulties students have with it. You should then be able to target your help more effectively in the lesson that follows.

Display Slide P-1 of the projector resource. Introduce the task briefly, helping the class to understand the problem and its context.

*Here are some pictures of gardens that have been designed. They are drawn carefully to scale so that the customer can get a good idea of what the finished garden will look like.*

*In this task, you will be taking the role of garden designers.*

*Does anyone have a nice-looking garden? What do you have in it?*

*Has anyone ever used a garden designer?*

This is an opportunity for students to talk briefly about any relevant experiences they may have had, in order to help them to get into the problem.

Give each student a copy of the assessment task *Design a Garden* and *Garden Plan*. They will also need some blank paper to work on.

*Spend a few minutes reading the first sheet, Design a Garden.*

If you cannot photocopy or print the sheets at precisely 100%, print also some copies of the paper rules that are provided. (This will distort the plan and the rules equally.) The paper rules work best if they are folded along the line next to the scale, to give a sharp, straight edge.

*Now look at the second sheet, Garden Plan. What direction are you looking from in this drawing?*

*The plan shows that the garden is 10 meters long.*

*Read through the resources carefully and follow the instructions for designing the garden.*

*Show your calculations and reasoning on a blank piece of paper.*

Students who sit together often produce similar answers, so when they come to compare their work, they have little to discuss. For this reason, we suggest that when students work individually on the assessment task, you ask them to move to different seats.

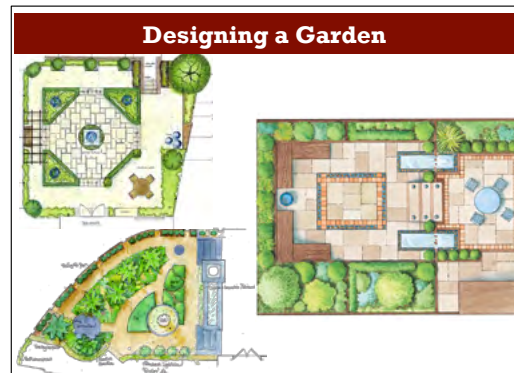

### Design a Garden

Imagine you are a garden designer.  
 You receive this email from a customer:

Dear Garden Designer,

I have moved into a house with a small garden that needs a total redesign. Please design my garden for me. I have attached an accurate scale drawing of my garden to this email. I've listed below some features I want in the garden. I will email you later about some other things I also want.

To start, please could you draw these features accurately on the plan, showing where you think they should go in the garden. Send me your plan with an explanation of your thinking.

Best wishes,  
 Mandy

<p><b>Shed</b></p> <p>I've ordered this shed. It is 2 meters wide, 3.25 meters long and 2.8 meters tall.</p>	
<p><b>Decking for barbecues</b></p> <p>I want some decking near the patio doors. It should be big enough to seat at least six people.</p>	
<p><b>Circular pond</b></p> <p>I would like a circular pond. I'd like its area to be about 7 m<sup>2</sup>.</p>	
<p><b>Path and Borders</b></p> <p>I would like some flower borders. These should not be more than one meter wide as I find wider ones difficult to look after.</p> <p>I'd like a gravel path 1 meter wide to go from the shed to the house and from the garden gate to the house.</p> <p>I will cover the rest with grass.</p>	

Use the sheet *Garden Plan* to draw the features from the email.  
 Record all your calculations and reasoning on a separate sheet.  
 Make sure to record the scale you use on the plan.



At the beginning of the formative assessment lesson allow them to return to their usual seats. Experience has shown that this produces more profitable discussions.

It is important that, as far as possible, students are allowed to answer the questions without assistance. If they are struggling to get started, ask questions to help students understand what is required, but make sure you do not do the task for them. The questions corresponding to the first issue in the *Common issues* table might be helpful.

### Assessing students' responses

Collect students' responses to the task. Make some notes on what their work reveals about their current levels of understanding and their different problem solving approaches.

We suggest that you do not score students' work. The research shows that this will be counterproductive, as it will encourage students to compare their scores and will distract their attention from what they can do to improve their mathematics.

Instead, help students to make further progress by summarizing their difficulties as a series of questions. Some suggestions for these are given in the *Common issues* table on the next page. These have been drawn from common difficulties observed in trials of this unit.

We suggest you make a list of your own questions, based on your students' work. We recommend you either:

- write one or two questions on each student's work, or
- give each student a printed version of your list of questions and highlight the questions for each individual student.

If you do not have time to do this, you could select a few questions that will be of help to the majority of students and write these on the board when you return the work to the students at the beginning of the lesson.

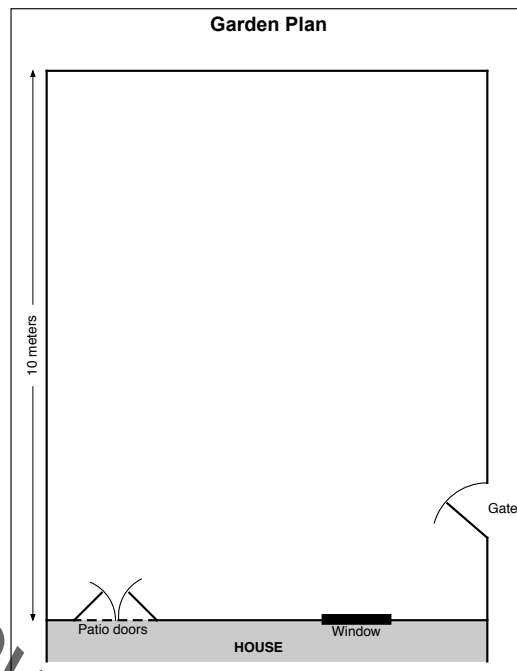

Common issues	Suggested questions and prompts
<p><b>Has little or no written work</b></p>	<ul style="list-style-type: none"> <li>• Which direction are you looking from when you make a plan view?</li> <li>• What useful information are you given? Underline this. What do you need to find out? How can you use the information you know to do this?</li> </ul>
<p><b>Lacks precision in their work</b></p> <p>For example: The student writes the scale in words or as an equality '2 cm is/= 1 m'.</p>	<ul style="list-style-type: none"> <li>• What do you mean by 'is' / 'equals'? Can you be more precise?</li> </ul>
<p><b>Has difficulty in expressing a scale</b></p> <p>For example: The student does not calculate the scale ratio or has calculated it incorrectly or drawn objects with no apparent calculations of scale.</p> <p>For example: The student has the scale ratio as 1 : 200 or 1cm : 4m.</p> <p>Or: The student writes the figures in reverse order, for example 50 : 1 instead of 1 : 50.</p> <p>Or: The student uses fractions in the scale ratio, for example 1 : 0.5.</p> <p>Or: The student has not calculated a unitary scale ratio, for example 2 cm : 1 m.</p>	<ul style="list-style-type: none"> <li>• How long is the real-life garden in centimeters? How long is the drawing in centimeters? Can you use this to figure out the scale?</li> <li>• If an object on the plan is 1cm long, how long is the real object? How do you know?</li> <li>• Usually a scale ratio is written in the order length on the plan : length in real life. What is your scale ratio when written this way?</li> <li>• Can you write the scale ratio more simply, without using fractions or decimals?</li> </ul>
<p><b>Has difficulty calculating measures on the plan</b></p> <p>For example: The student has difficulty when the actual lengths are not whole numbers.</p>	<ul style="list-style-type: none"> <li>• How do you convert 1m in real life to a measurement on the plan? What about 3m? Now apply the same method to figure out what the length 3.25 m is on the plan.</li> </ul>
<p><b>Does not calculate an appropriate radius for the pond</b></p> <p>For example: The student uses guess and check unsuccessfully.</p> <p>Or: The student does not use consistent units in calculations.</p>	<ul style="list-style-type: none"> <li>• Can you draw a square with area 7 m<sup>2</sup>? Could this help you to draw a circle with a similar area?</li> <li>• Can you pick a radius for the pond and work out what area that would give?</li> <li>• What is the formula for the area of a circle? Can you use this to find the pond's radius?</li> </ul>
<p><b>Does not explain a method for determining the area needed for the decking</b></p>	<ul style="list-style-type: none"> <li>• How much space do six people occupy when sitting down? How much space do you think you need to allow between them?</li> </ul>
<p><b>Makes a technical error</b></p>	<ul style="list-style-type: none"> <li>• How can you determine that your scale is/measures are reasonable? What's your evidence?</li> <li>• How can you verify that your design has met all of Mandy's requests?</li> </ul>

## SUGGESTED LESSON OUTLINE

### Individual work (15 minutes)

Return the assessment task to the students along with some blank paper. If you did not add questions to individual pieces of work, write your list of questions on the board. Students can then select questions appropriate to their own work.

Begin the lesson by briefly reintroducing the problem:

*Recall your work on the design task. What was the task about?*

*Today we are going to improve your work on this task.*

*I have looked over your papers and have some questions for you.*

*Work individually. Read my questions. Use the questions to figure out how to improve your work. Write notes on the sheet, or on the blank paper, about what you think will improve your work.*

While students are working, focus your attention on any students that struggled to begin the assessment task, to identify the scale factor or make sense of the plan view. Give students time to revise their work, using your written questions and notice changes they make. Use what you notice to organize groupings for the next task. After ten minutes if there is any student who continues to struggle beginning the task, drawing objects in plan view, or finding the scale factor, you might pair him or her with a student who has succeeded on that part of the work in the next task.

### Collaborative small group work: improving the Garden Plan (25 minutes)

Give each small group a copy of the task sheet, *Garden Plan*, a large sheet of poster paper, a felt-tipped pen, and a glue stick.

Slide P-2 of the projector resource summarizes the process students should follow:

Collaborating With Your Partner
<ul style="list-style-type: none"><li>• Take turns explaining your <i>Garden Plan</i> to your partner. Explain how you would improve your solution. Listen to each other carefully.</li><li>• Ask 'clarifying questions' that will help you understand your partner's reasoning.</li><li>• When you have both taken a turn, decide how to design a new better garden together.</li><li>• Draw your plan on the <i>Garden Plan</i> sheet and stick it in the middle of the poster paper.</li><li>• Use the space around the edge to write your reasoning, decisions, and calculations.</li></ul>

While students are working you have three tasks: to notice students' strengths and difficulties, to support their reasoning, and to ensure collaborative working.

#### Notice students' strengths and difficulties

Note different approaches to the task and the assumptions students make.

Are there any students who struggle to imagine what objects would look like in plan view?

Do any students continue to struggle with using the scale? Notice how students express the scale ratio, their use of units and whether they express it in conventional form.

Are there any students struggling with calculating measures on the plan or translating measures on the plan to real-life measures? They may be having difficulty working with scaling relationships. Students might not recognize that there is a multiplicative relationship between the two measures and attempt to use additive methods. Other students might use informal methods and they may then find it difficult to perform calculations on non-integer values.

Do students struggle with the relationships between units? How do they handle moving to relationships between units when area and volume are introduced?

Notice how students carry out their work. Do they plan, developing a strategy? Do students work systematically? What do students do when they become stuck?

Do students check their work? Have students made practical mistakes such as placing the shed right next to the window? Do students check whether answers are sensible by thinking about the context?

You may want to use the questions in the *Common issues* table to support your own questioning. If the whole class is struggling on the same issue, you could write one or two relevant questions on the board and hold a brief whole-class discussion.

#### **Support students' reasoning**

Rather than resolve students' difficulties for them, ask questions to support them in making progress. You might ask strategic questions, to help them direct and organize their work:

*What have you done so far?*

*Can you explain your strategy?*

*What math do you know about [working with scale ratios/the area of a circle]? How can you use that to solve this problem?*

If students have made errors, or are struggling to make progress with a particular part of the design, ask more focused questions to help them make sense of the mathematics.

*Think of a right rectangular prism. If you were drawing a plan view, what would it look like?*

*Tell me the information given about measures on the Garden Plan sheet.*

If students continue to struggle, move the lesson on to the *Collaborative Analysis of Assistants' Methods*. These show a variety of approaches to drawing the pond feature. When students have analyzed the sample work they are to return to improving their own garden design.

#### **Develop collaborative working**

Encourage students to take turns in talking and to listen carefully to each other's explanations. Ask the students to be responsible for making sure that they all understand.

If one student dominates the written activities, encourage turn taking there too. You can check that there are samples of each student's handwriting on the poster.

Make sure that all students in the group are able to explain what is written on the poster. If you see one student writing an explanation, ask another student to explain to you how they figured out their solution.

#### **Poster gallery (20 minutes)**

Once students have had sufficient time producing an improved collaborative garden design organize them so that one student stays with the group's poster and the other visits another group's poster.

Give each student two sticky notes and explain how they are to share their work.

Slide P-3 of the projector resource summarizes the process students should follow:

Poster Gallery
<ul style="list-style-type: none"><li>• One person from each group get up and visit another group's poster.</li><li>• If you are the visitor, read the poster. If there is math you do not understand, ask clarifying questions.</li><li>• If you are staying with your poster, explain the math to the visitor.</li><li>• If you find things you could do to improve your poster, write them on your sticky notes and attach to your poster.</li></ul>

After five minutes, ask students to swap roles.

#### Extending the lesson over two days

If you are planning to teach the unit over two class periods, this is a good place to break. Begin the next lesson with a quick review of work so far and then move on to the next activity.

#### Collaborative analysis of Assistants' Methods (30 minutes)

Organize students into pairs or threes. Distribute copies of each of the *Assistants' Methods* to each group.

*Imagine you have three assistants who have worked on designing this garden. Their work is incomplete. They all use different methods in their work.*

*Your job is to try to understand what they have done and to improve their work.*

Slide P-4 of the projector resource summarizes the process students should follow:

Analysis of Assistants' Methods
<ul style="list-style-type: none"><li>• Choose one assistant's work and read it carefully.</li><li>• Answer the questions underneath.</li><li>• Try to understand what they have done and think about how the work could be improved.</li><li>• Take turns explaining your thinking to your partner.</li><li>• Listen carefully and ask clarifying questions.</li><li>• When your group has reached its conclusions, write your ideas below the assistant's work.</li><li>• Now check out another assistant's work in the same way.</li></ul>

This task gives students an opportunity to evaluate different approaches to the task. The methods used by the assistants are incomplete and contain some errors. They illustrate different strategies for figuring out measures for the length of objects on the scale drawing and obtaining real-life measures from the lengths drawn on the plan.

While students work, notice their strengths and difficulties, support their reasoning, and develop collaborative working as before. Listen to students' discussion of the explanations. Is there one particular method that many students struggle to understand? Do any students reason strongly about a particular method? Note this and call on their expertise in later discussions.

Encourage students to focus on evaluating the math contained in the assistants' work, rather than surface features like neatness. Ask questions to help them articulate detailed and accurate reasoning before they record their answers on the worksheets. For example, if students are struggling to find ways to improve the work, suggest they try the methods out:

*Use Bill's rule to calculate the length of the shed.*

*Use Hina's result for the radius of the pond on your drawing.*

*What do you think the horizontal and vertical lines on Lisa's graph are about?*

*Use Lisa's method to find the width of the shed.*

*Do you agree with their answers?*

If one student writes an answer to a question, ask the other student to explain that answer. If one student's reasoning is incomplete, ask the other to help articulate the reasoning more fully.

Below, we discuss math issues arising from each of the *Assistants' Methods*.

**Bill** has provided a 'rule' to use for drawing the features in the plan. His rule is a double number line, specifying the relationship between one set of numbers and another. The scale of Bill's rule is correct but he does not make it explicit.

To measure more accurately Bill could use millimeter-squared paper.

Bill uses his rule to accurately draw five squares, representing  $5 \text{ m}^2$ . He has also drawn four right triangles, representing a further  $2 \text{ m}^2$ . Bill has used this framework to sketch the outline of a pond that has a surface area slightly bigger than  $7 \text{ m}^2$ . Bill has not found the radius on the plan for his radius of the garden pond in real-life.

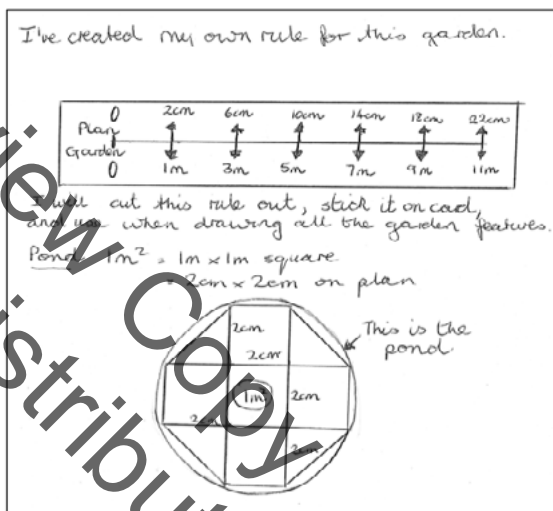

**Hina** uses guess and check to figure out the radius of the pond. This method does provide a correct answer. If an exact measurement were required, then an algebraic method could be more appropriate (and more efficient).

Hina leaves her ratios in different units of measure but does not record the units, giving the ratio  $1 : 2$ . This is incorrect: the ratio is  $1 \text{ cm} : 0.5\text{m}$  or  $1 : 50$ . The mathematical convention is, also, to write the plan measure before the real-life length. In effect, Hina works with the ratio  $1\text{m} : 2\text{cm}$ .

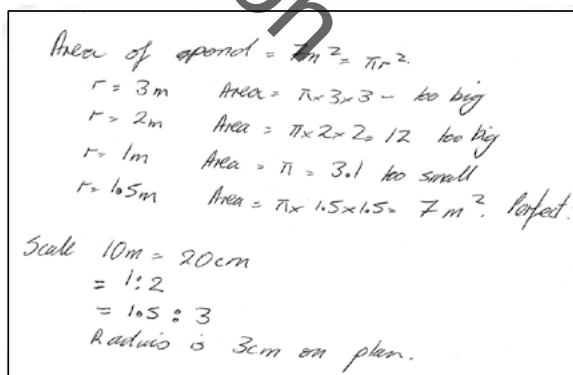

Lisa uses an algebraic method to figure out the radius of the pond.

She rounds  $\pi$  down to 3 (and does not explain why he has done this) and

rounds the square root of  $\frac{7}{3}$  down to

$r = 1.5$  m.

Calculating the surface area of the pond from these values:

$$A = \pi r^2 = 3 \times 1.5 \times 1.5 = 6.75m^2$$

Lisa has used a graph to figure out the radius of the pond on the plan. She can read from the graph the measurement of any garden length on the plan and likewise read any plan length from a given garden length. Lisa's graphical method gives her a way of calculating the measures in Mandy's first email. It would be good to state the units for the variables on each axis.

However, the graph is not a good method for finer degrees of accuracy. For this Lisa could use millimeter graph paper. Drawing a graph for this plan is not efficient for such a simple scale.

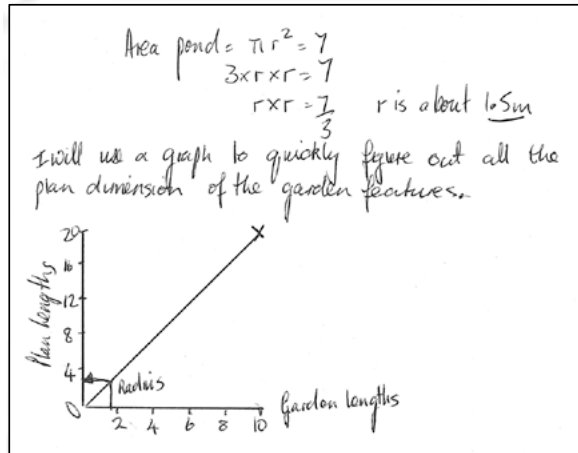

**Whole-class discussion: comparing different approaches (20 minutes)**

Hold a whole-class discussion to consider the different approaches used. Slides P-5 to P-7 may be helpful with this discussion; they show the assistants' methods.

Ask the students to compare and evaluate the methods:

*Which do you think is the best method? Why? What are the advantages of that method?*

*Which of the assistants' methods did you find most difficult to understand?*

*What was difficult about that method?*

*Which method might you use yourself? Why?*

*If the scale was more complicated, for example 1 : 25, which method would you prefer?*

**Follow-up lesson: review work (10 minutes)**

Remind students of their work on *Designing a Garden* and the different methods they have seen and used. Ask students to sit in the small groups in which they worked during the lesson. Return individual and group scripts and give students a few minutes to read their work.

Distribute the sheet *How Did You Work?* and ask students to complete this questionnaire.

The questionnaire should help students review their progress. Some teachers give this task for homework.

**Optional follow-up lesson: extension work (30 minutes)**

Hand out *Mandy's Second Email* sheet:

*Mandy wants some costings for her garden. Can you estimate these for her?*

Students could continue to work in the same groups or in different ones. If there is time, you could hold a whole-class discussion in which students share their solutions.

Review Copy  
Not for Distribution



## SOLUTIONS

### Assessment task: *Design a Garden*

The scale is calculated using the length of the garden on the plan, 20cm, and the given real-life measure of 10 m. 1 cm on the plan is equivalent to 0.5m in the garden.

The scale is 1 : 50 or 1cm : 0.5m.

There are many ways students could draw the design. Below are some examples of how students could efficiently figure out measurements on the plan of actual measurements in the garden.

#### A graphical method

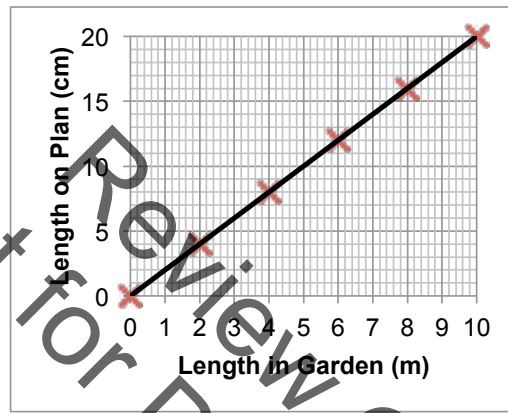

More generally if 1cm on the plan represents  $a$  m, 1 m on the ground represents  $\frac{1}{a}$  cm on the plan.

#### A scale rule or double number line method



#### Numerical methods

The ratio is 1 : 50 or 1 cm : 0.5 m.

Given a length on the plan, the real-life length might be calculated by multiplying by 50 to find its length in centimeters, or multiplying by 0.5 to find its length in meters.

Given a real-life length in meters, the plan length in centimeters might be found by dividing the measure by 0.5 or multiplying by  $\frac{1}{0.5} = 2$ .

Given a real-life length in centimeters, the plan length might be found by dividing the measure by 50, or multiplying by  $\frac{1}{50} = 0.02$ .

Some students may attempt to use the method of setting up a proportion and cross-multiplying:

$$1 : 50 = x : 160$$

$$\text{So } \frac{1}{50} = \frac{x}{160}$$

$$\frac{1 \times 160}{50} = x$$

$$\frac{16}{5} = x = 3.2$$

This is a powerful method, but some students may have learned the procedure without linking it to which variables stand in which multiplicative relationships and which units are involved.

**Garden features**

Students may use their own method, or one of the above methods to figure out the dimensions on the plan of the garden features:

Feature	Dimensions on Plan
<p><b>Shed</b>                      I've ordered this shed. It is 2 meters wide, 3.25 meters long and 2.8 meters tall.</p>	4 cm × 6.5 cm. Students do not need to calculate the height because that is not represented on the plan.
<p><b>Decking for barbeques</b>                      I'd like this near the patio doors. It should be big enough to seat at least six people.</p>	If the decking is rectangular then the dimensions would be at least 3 m × 3 m. This would be 6 cm × 6 cm on the plan.
<p><b>Circular pond</b>                      I would like a circular pond. I'd like the surface area to be about 7m<sup>2</sup>.</p>	$\pi r^2 = 7 \text{ m}^2$ so $r = 1.5 \text{ m}$ . The plan radius should be about 3 cm. Counting squares to find a circle with area about 7 m <sup>2</sup> is an adequate method.
<p><b>Path and Borders</b>                      I would like some flower borders. I find borders wider than a meter difficult to garden. I'd like a 1 meter wide path to go from the shed to the house and from the garden gate to the house.  <i>Extension:</i>                      Please tell me the approximate cost of the gravel path you have drawn.                      The gravel should be about 8cm deep.                      Gravel costs \$40 per cubic meter.</p>	The path and borders should be shown 2 cm wide and in appropriate places.  <i>Extension:</i> Volume of path = path length in meters × 1m × 0.08m. Cost of path = volume of path × 40 (\$ per cubic meter) (= Path length (m) × 3.2 (\$ per m))
<p><b>Grass</b>                      Please tell me the approximate cost of the grass area. Grass costs \$3 per square meter.</p>	Students' answers will vary. Some will try to estimate the remaining area directly by dividing the garden into pieces and estimating the area of each piece. Others may find the combined areas of the shed, patio, pond, path and borders and subtract this total from the area of the garden.

## Design a Garden







Imagine you are a garden designer.  
You receive this email from a customer:

Dear Garden Designer,

I have moved into a house with a small garden that needs a total redesign. Please design my garden for me. I have attached an accurate scale drawing of my garden to this email. I've listed below some features I want in the garden. I will email you later about some other things I also want.

To start, please could you draw these features accurately on the plan, showing where you think they should go in the garden. Send me your plan with an explanation of your thinking.

Best wishes,  
Mandy

<b>Shed</b> I've ordered this shed. It is 2 meters wide, 3.25 meters long and 2.8 meters tall.	
<b>Decking for barbeques</b> I want some decking near the patio doors. It should be big enough to seat at least six people.	
<b>Circular pond</b> I would like a circular pond. I'd like its area to be about $7 \text{ m}^2$ .	
<b>Path and Borders</b> I would like some flower borders. These should not be more than one meter wide as I find wider ones difficult to look after. I'd like a gravel path 1 meter wide to go from the shed to the house and from the garden gate to the house. I will cover the rest with grass.	

Use the sheet *Garden Plan* to draw the features from the email.  
Record all your calculations and reasoning on a separate sheet.  
Make sure to record the scale you use on the plan.

### Garden Plan

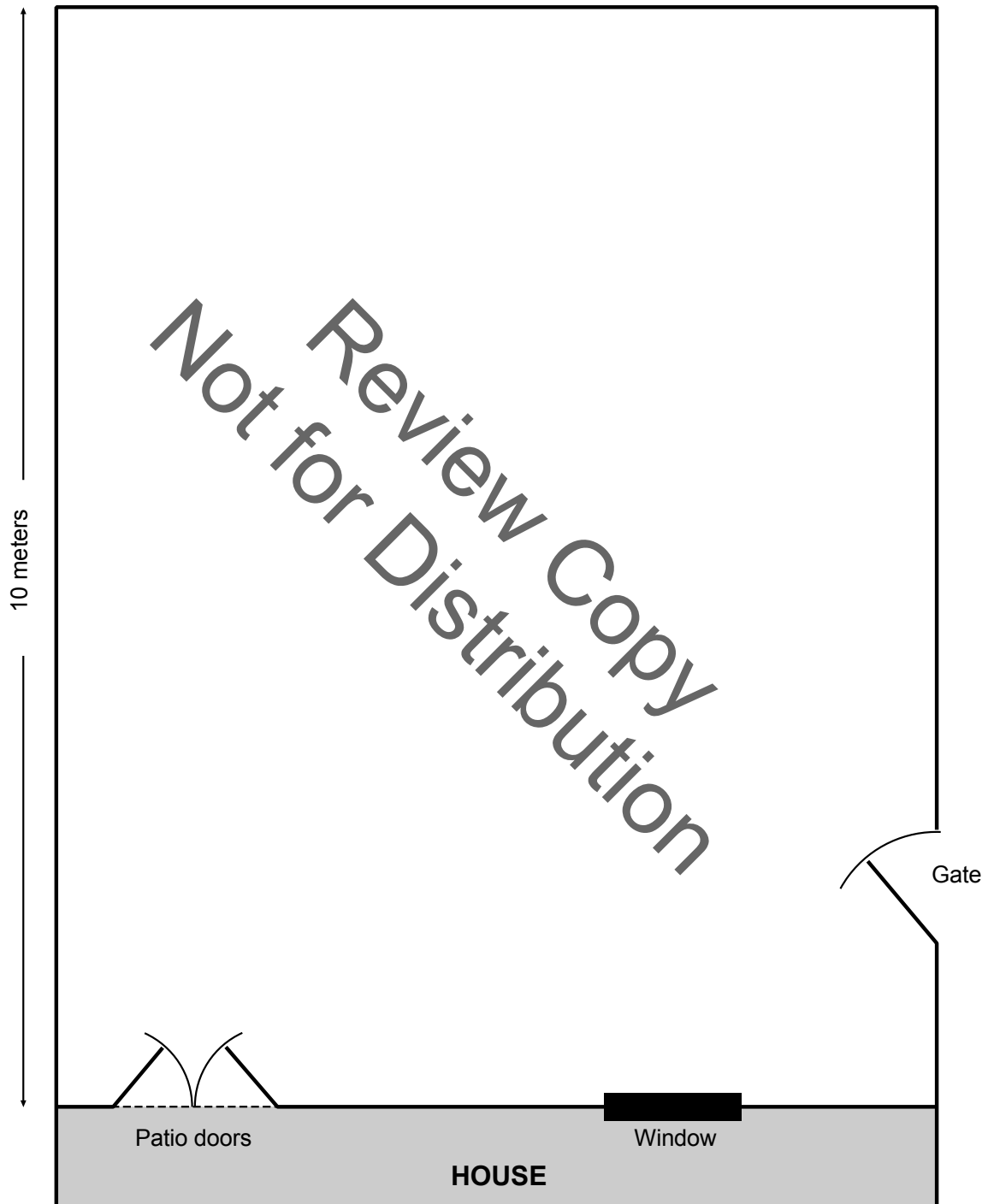

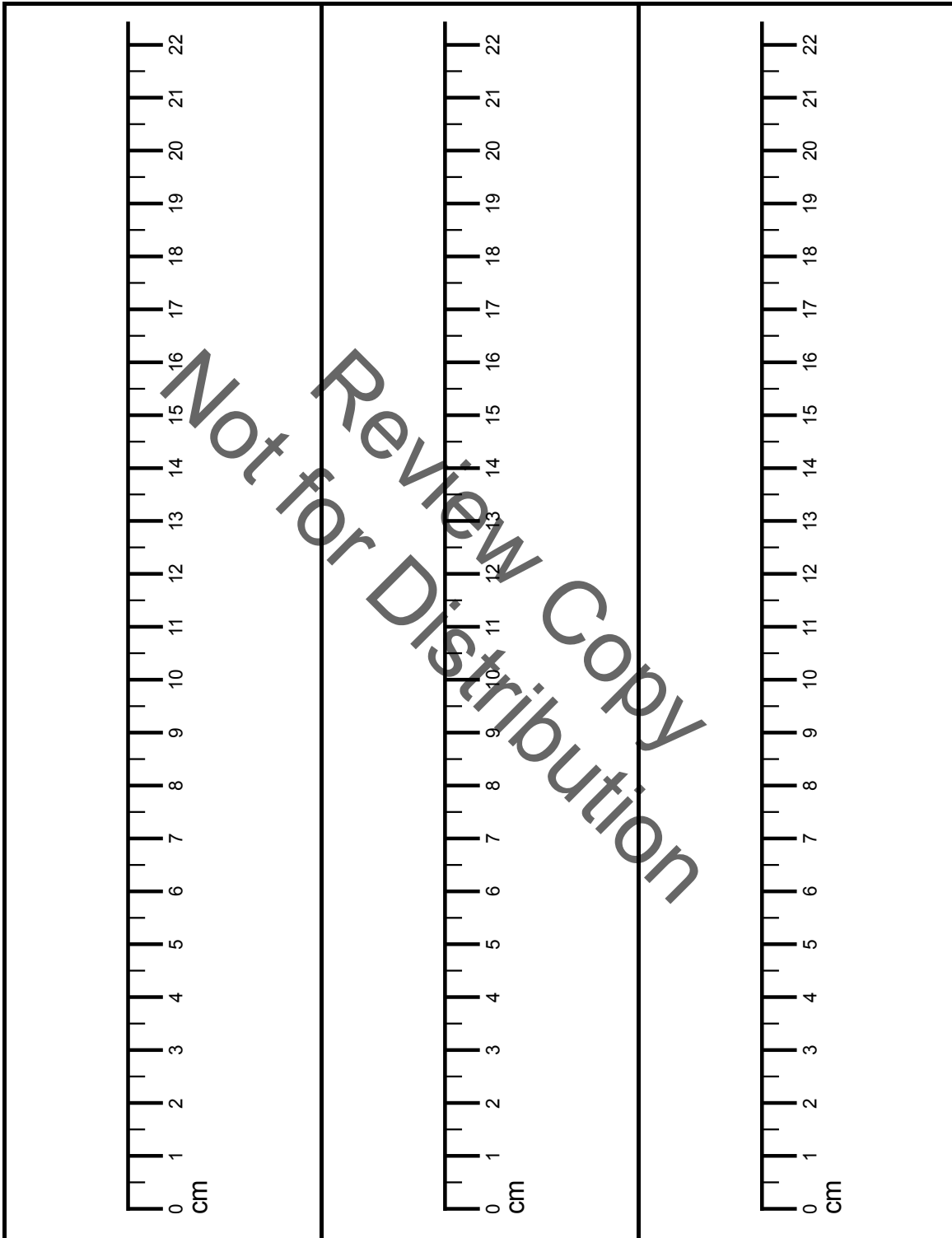

## Assistant Bill's Method

I've created my own rule for this garden.

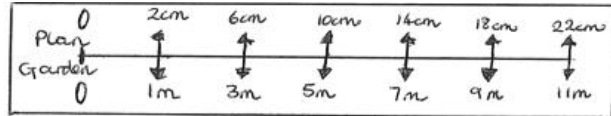

I will cut this rule out, stick it on card, and use when drawing all the garden features.

Pond  $1m^2 = 1m \times 1m$  square  
 $2cm \times 2cm$  on plan

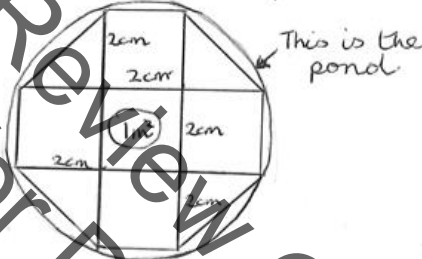

What is Bill's method for calculating lengths on the plan?

.....

.....

.....

.....

Are there any problems with Bill's method? Explain how Bill could overcome these problems.

.....

.....

.....

.....

Explain Bill's method for drawing the pond on the plan.

.....

.....

.....

.....

### Assistant Hina's Method

Area of pond =  $7m^2 = \pi r^2$   
 $r = 3m$  Area =  $\pi \times 3 \times 3$  - too big  
 $r = 2m$  Area =  $\pi \times 2 \times 2 = 12$  too big  
 $r = 1m$  Area =  $\pi = 3.1$  too small  
 $r = 1.5m$  Area =  $\pi \times 1.5 \times 1.5 = 7m^2$  Perfect!

Scale  $10m = 20cm$   
 $= 1:2$   
 $= 1.5:3$   
Radius =  $3cm$  on plan.

What is Hina's method for calculating the radius of the pond on the plan?

.....

.....

.....

.....

.....

.....

How could Hina's method be improved?

.....

.....

.....

.....

.....

### Assistant Lisa's Method

$$\begin{aligned} \text{Area pond} &= \pi r^2 = 7 \\ 3 \times r \times r &= 7 \\ r \times r &= \frac{7}{3} \quad r \text{ is about } \underline{1.5m} \end{aligned}$$

I will use a graph to quickly figure out all the plan dimension of the garden features.



What is Lisa's method to find the radius of the pond on the plan?

.....

.....

.....

.....

.....

Are there any problems with Lisa's method? Explain how Lisa could overcome these problems.

.....

.....

.....

.....

.....



## Mandy's Second Email

Hello again,

I need to know some costs of the things on your plan.

Please can you work these out for me?

Best wishes,

Mandy

### Gravel path

Please tell me the approximate cost of the gravel path you have drawn.

The gravel should be about 8 cm deep.

Gravel costs \$40 per cubic meter.



### Grass

Please tell me the approximate cost of the grass area.

Grass costs \$3 per square meter.

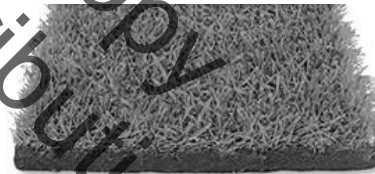

## How Did You Work?

1. Please tick one sentence about your individual work:

Our group's method was **better** than my own work.

Our group's method was **not better** than my own work.

Explain your response:

Not for Review Copy Distribution

2. Underline the part of the sentence that applies to your group's work:

Our group method was similar to:

Bill's Method

Hina's Method

Lisa's Method

None of the assistants' methods.

If your work was similar to one of the assistant's methods, answer the question below:

If your work was similar to none of the assistants' methods, answer the question below:

I prefer our work/the assistant's method because

Our work was different from every assistant's method because

3. What advice would you give to a student about to start this task?



## Collaborating With Your Partner

- Take turns explaining your *Garden Plan* to your partner. Explain how you would improve your solution. Listen to each other carefully.
- Ask ‘clarifying questions’ that will help you understand your partner’s reasoning.
- When you have both taken a turn, decide how to design a new, better garden together.
- Draw your plan on the *Garden Plan* sheet and stick it in the middle of the poster paper.
- Use the space around the edge to write your reasoning, decisions, and calculations.

## Poster Gallery

- One person from each group get up and visit another group's poster.
- If you are the visitor, read the poster. If there is math you do not understand, ask clarifying questions.
- If you are staying with your poster, explain the math to the visitor.
- If you find things you could do to improve your poster, write them on your sticky notes and attach to your poster.

## Analysis of Assistants' Methods

- Choose one assistant's work and read it carefully.
- Answer the questions underneath.
- Try to understand what they have done and think about how the work could be improved.
- Take turns explaining your thinking to your partner.
- Listen carefully and ask clarifying questions.
- When your group has reached its conclusions, write your ideas below the assistant's work.
- Now check out another assistant's work in the same way.

# Assistant Bill's Method

I've created my own rule for this garden.

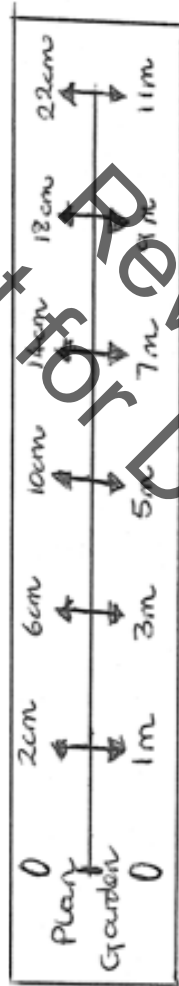

I will cut this rule out, stick it on card, and use when drawing all the garden features.

Pond  $1m^2 = 1m \times 1m$  square  
 $= 2cm \times 2cm$  on plan

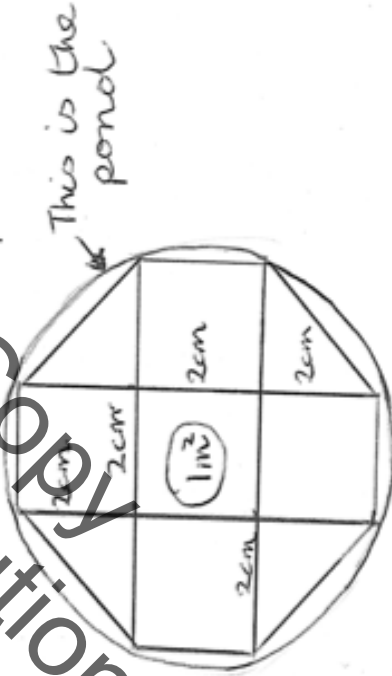

# Assistant Hina's Method

Area of pond =  $7m^2 = 7 \times 7$

$r = 3m$  Area =  $7 \times 3 = 21$  - too big

$r = 2m$  Area =  $7 \times 2 = 14$  too big

$r = 1m$  Area =  $7 \times 1 = 7$  too small

$r = 1.5m$  Area =  $7 \times 1.5 = 10.5$  Perfect!

Scale  $10m = 20cm$

$= 1:2$

$= 1.5:3$

Radius is  $3cm$  on plan.



# Assistant Lisa's Method

$$\begin{aligned} \text{Area pond} &= \pi r^2 = 7 \\ 3 \times r \times r &= 7 \\ r \times r &= \frac{7}{3} \end{aligned}$$

$r$  is about 1.5m

I will use a graph to quickly figure out all the plan dimensions of the garden features.

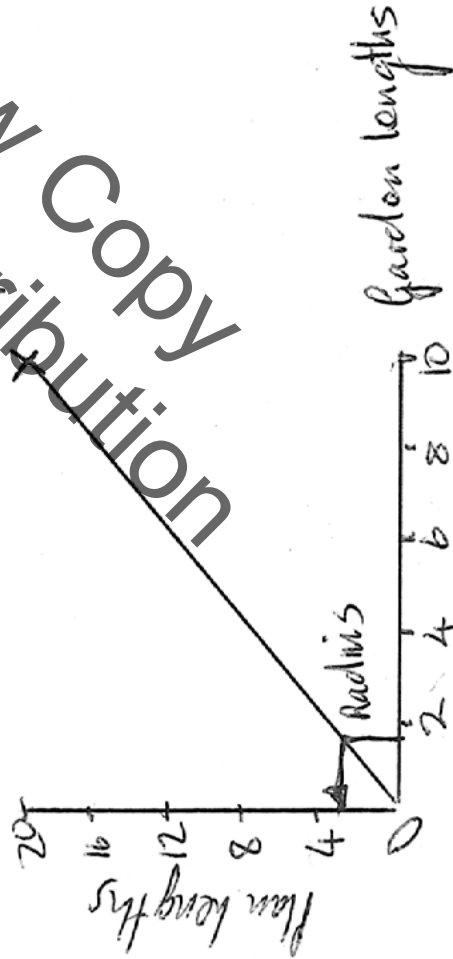

Not for Redistribution

## Mathematics Assessment Project **Classroom Challenges**

These materials were designed and developed by the  
Shell Center Team at the Center for Research in Mathematical Education  
University of Nottingham, England:

**Malcolm Swan,**  
**Nichola Clarke, Clare Dawson, Sheila Evans, Colin Foster, and Marie Joubert**  
with  
**Hugh Burkhardt, Rita Crust, Andy Noyes, and Daniel Pead**

We are grateful to the many teachers and students, in the UK and the US,  
who took part in the classroom trials that played a critical role in developing these materials

The classroom observation teams in the US were led by  
**David Foster, Mary Bouck, and Diane Schaefer**

This project was conceived and directed for  
The Mathematics Assessment Resource Service (MARS) by  
**Alan Schoenfeld** at the University of California, Berkeley, and  
**Hugh Burkhardt, Daniel Pead, and Malcolm Swan** at the University of Nottingham

Thanks also to Mat Crosier, Anne Floyde, Michael Galan, Judith Mills, Nick Orchard, and Alvaro Villanueva who contributed to the design and production of these materials

This development would not have been possible without the support of  
**Bill & Melinda Gates Foundation**

We are particularly grateful to  
**Carina Wong, Melissa Chabran, and Jamie McKee**

The full collection of Mathematics Assessment Project materials is available from

<http://map.mathshell.org>

© 2015 MARS, Shell Center, University of Nottingham  
This material may be reproduced and distributed, without modification, for non-commercial purposes,  
under the Creative Commons License detailed at <http://creativecommons.org/licenses/by-nc-nd/3.0/>  
All other rights reserved.  
Please contact [map.info@mathshell.org](mailto:map.info@mathshell.org) if this license does not meet your needs.

## Ratio and Proportional Relationships

# Lesson 12 of 12

## Ratios and Proportions (Revisited)

### Description:

---

Students will be complete this unit by revisiting the Entry Event. They will apply their knowledge of ratios, unit rates, and proportions to sort through the clues and deduce which suspect robbed the National Bank of illuminations.

### College- and Career-Readiness Standards Addressed:

---

- RP.1 Understand the concept of a ratio and use ratio language to describe a ratio relationship between two quantities.
- RP.2 Understand the concept of a unit rate  $a/b$  associated with a ratio  $a:b$  with  $b \neq 0$ , and use rate language in the context of a ratio relationship.
- RP.4 Compute unit rates associated with ratios of fractions, including ratios of lengths, areas and other quantities measured in like or different units.
- RP.6 Use proportional relationships to solve multi-step ratio and percent problems.

### Process Readiness Indicator(s) Emphasized:

---

- PRI 1: Make sense of problems and persevere in solving through reasoning and exploration.
- PRI 2: Reason abstractly and quantitatively by using multiple forms of representations to make sense of and understand mathematics.
- PRI 3: Describe and justify mathematical understandings by constructing viable arguments, critiquing the reasoning of other and engaging in meaningful mathematical discourse.
- PRI 4: Contextualize mathematical ideas by connecting them to real-world situations. Model with mathematics.
- PRI 6: Attend to precision.
- PRI 9: Demonstrate flexible use of strategies and methods while reflecting on which procedures
- PRI 10: Reflect on mistakes and misconceptions to improve mathematical understanding.

Sequence of Instruction

Activities Checklist

Engage

*Teacher’s Notes: This is the same activity as the Entry Event for this unit. In this lesson, students assume the role of a detective investigating a bank robbery. Students use four clues to help them apprehend the thief. This content is from a lesson titled “Highway Robbery” found at <http://illuminations.nctm.org/Lesson.aspx?id=3128>*

Below is a suspect matrix with the clue values needed to make a particular suspect the actual thief. Before class, choose a suspect different than who was chosen in the Entry Event, and fill in the blanks on the Clue Sheet Overhead. The information you put on the Clue Sheet will lead the students to your chosen thief. You can also create your own suspect list, using people you make up or people you know, such as other teachers or classmates. Having two or three possible values for each characteristic makes it easier to have students find suspects to match their calculations.

**Suspect Matrix**

<b>Roy G. Biv</b>	<b>Jen Eric</b>	<b>Matthew Matics</b>
Clue 1 Question 1: 15 cm	Clue 1 Question 1: 13.2 cm	Clue 1 Question 1: 15 cm
Clue 2 Question 2: 25 pounds	Clue 2 Question 2: 25 pounds	Clue 2 Question 2: 32 pounds
Clue 3 Question 5: 16 miles/gallon	Clue 3 Question 5: 8 miles/gallon	Clue 3 Question 5: 8 miles/gallon
<b>Polly Hedron</b>	<b>Evan Number</b>	<b>Al T. Tude</b>
Clue 1 Question 1: 13.2 cm	Clue 1 Question 1: 13.2 cm	Clue 1 Question 1: 15 cm
Clue 2 Question 2: 32 pounds	Clue 2 Question 2: 25 pounds	Clue 2 Question 2: 32 pounds
Clue 3 Question 5: 8 miles/gallon	Clue 3 Question 5: 25 miles/gallon	Clue 3 Question 5: 16 miles/gallon

Give each student a pretend police badge as they enter the classroom. Explain they are police detectives today.

Address the class with an opening statement like, “Detectives, we have received an urgent email from the captain of police. We have been chosen for this task because of our superior math skills. I have created a copy of the note for everyone.” Display the Clue Sheet Overhead found at <http://illuminations.nctm.org/uploadedFiles/Content/Lessons/Resources/6-8/Clue%20Sheet%20OH.pdf>.

*Dear Detective,*

*Someone has robbed the National Bank of Illuminations in Washington D.C. It is your job to use the clues left by the perpetrators to locate and apprehend the robber. Your tools will be your power of deduction and your mathematical knowledge. Good luck cracking this case!*

*Sincerely, Captain P. Thagoras*

**CLUES:**

- The perpetrator is \_\_\_\_ cm tall in the security camera image.
- \_\_\_\_ pounds of quarters were stolen.
- The getaway car was a silver 1989 HN Cosine which travels \_\_\_\_ miles per gallon of gas.

*Explore*

**PRI 1**  
**PRI 2**  
**PRI 4**  
**PRI 6**

Engage students in quantitative reasoning practices that include attending to the meaning of quantities and considering the units involved. Also, ask students to attend to precision as they utilize the clues to find the perpetrator.

Group students in pairs. Instruct students to find the *Clue Activity Sheet* in the Student Manual. Continue to display the *Clue Sheet Overhead* on the board.

*Teacher's Note: The Clue Activity Sheet can be found at [http://illuminations.nctm.org/uploadedFiles/Content/Lessons/Resources/6-8/Clue\\_Sheet\\_AS.pdf](http://illuminations.nctm.org/uploadedFiles/Content/Lessons/Resources/6-8/Clue_Sheet_AS.pdf).*

Facilitate a whole-class discussion about the clues. Ask students questions like the following:

- “What do you think the perpetrator would do with \_\_\_\_ pounds of quarters?”
- “If the perpetrator’s car gets \_\_\_\_ miles per gallon, do you think he/she is very far away?”

*Teacher's Note: Some students, especially students whose first language is not English, may not be familiar with the vocabulary words perpetrator, apprehend, and deduction. As you read the letter, pause to ask for volunteers who can define each of these words.*

- *Perpetrator* – a person who committed the crime
- *Apprehend* – to arrest someone
- *Deduction* – to reach a conclusion

Instruct students to fill in the blanks in Questions 1, 2, and 5 on the *Clue Activity Sheet*. Instruct students to find the *Suspect List Activity Sheet* included in the Student Manual, which summarizes what is known about each person. Discuss Item 1 on the *Suspect List Activity Sheet* with the class and explain students will need both the *Clue Activity Sheet* and the *Suspect List Activity Sheet* to find the perpetrator.

*Teacher's Note: The Suspect List Activity Sheet can be found at [http://illuminations.nctm.org/uploadedFiles/Content/Lessons/Resources/6-8/Suspect\\_List%20AS.pdf](http://illuminations.nctm.org/uploadedFiles/Content/Lessons/Resources/6-8/Suspect_List%20AS.pdf).*

Monitor students' work, and listen for students who are struggling. Students may have difficulty with answering Question 1 on the *Clue Activity Sheet* correctly. Some students will leave their answers as decimals, but the suspect list does not have decimal heights.

Here are some examples of guiding questions:

- What do you notice about the relationship between the missing information and the information given on the "Suspect List"?
- How can this relationship help you to solve this problem?
- Do any of your answers match the answers on the suspect list? What do you notice about the answers on the suspect list? So what do you have to do?
- The most common problem will be students' making the decimal the number of inches, like 5.5 feet must be 5 feet 5 inches. Ask, "How many inches are in half a foot? Then, what should the height be?"

**Commentary for the Teacher:** Students will use their answers from Clue 3 in Clue 4. After measuring the scale line in centimeters, a proportion will help them find the perpetrator's city. Be prepared to help students read a ruler. Remind them that the smaller lines represent millimeters, which are 0.1 centimeters.

## Explanation

**PRI 3**  
**PRI 9**  
**PRI 10**

Facilitate a whole-group discussion.

1. How did your group solve the problem? Does your group agree with this method? Explain. *[At this point, do not give evaluative feedback. Just allow students to share and critique.]*
2. What are some things in real life that would have affected the answers you got? *[Questions 2 and 3 assume that all the quarters weigh exactly the same. Question 6 assumes that the car was getting 25 miles per gallon. Gas mileage varies based on driving conditions, such as speed.]*
3. What is a tip you can give a student who is struggling to solve these problems? What possible misconceptions or mistakes do you think other students might make in completing this activity?

## Practice Together in Small Groups

**PRI 1**

Students will continue working in pairs on the Robbery problem. At the end of this lesson, the teacher should make a note of misconceptions in the students' work.

## Evaluate Understanding

Have students work backward. Assign different suspects to different pairs of students to create their own sets of clues. For example, assign one group the suspect "Matthew Matics". This group uses the information on the "Suspect List" to work backward and create clues that would lead to this suspect. Then have students swap and try to find the new perpetrator.



# SREB

## SREB Readiness Courses

# Ready for High School: Math

### Math Unit 3

### Probability and One-Variable Statistics

Not for Review Copy Distribution

Southern  
Regional  
Education  
Board

592 Tenth Street, NW  
Atlanta, GA 30318  
(404) 875-9211

[www.sreb.org](http://www.sreb.org)





## Unit 3 . Probability and One-Variable Statistics

### Overview

This unit deals with calculating probability and understanding one-variable statistics. Students are asked to calculate the probability of compound events, describe the effects a single value can have on summary statistics, and utilize data to learn about specific populations.

### Essential Questions:

---

- *How is the likelihood of an event determined and communicated?*
- *What types of questions will result in statistical variability?*
- *How can you determine the best measure of center and the best measure of variability for a data set?*
- *How can we use mathematics to provide models that help us interpret data, make predictions, and better understand the world in which we live, and what are the limits of these models?*

## College- and Career-Readiness Standards:

---

- SP.1 Recognize a statistical question as one that anticipates variability in the data related to the question and accounts for it in the answers. *For example, “How old am I?” is not a statistical question, but “How old are the students in my school?” is a statistical question because one anticipates variability in students’ ages.*
- SP.2 Understand that a set of data collected to answer a statistical question has a distribution which can be described by its center, spread, and overall shape.
- SP.3 Recognize that a measure of center for a numerical data set summarizes all of its values with a single number, while a measure of variation describes how its values vary with a single number.
- SP.4 Display numerical data in plots on a number line, including dot plots, histograms, and box plots.
- SP.5 Summarize numerical data sets in relation to their context, such as by:
  - a. Reporting the number of observations.
  - b. Describing the nature of the attribute under investigation, including how it was measured and its units of measurement
  - c. Giving quantitative measures of center (median and/or mean) and variability (interquartile range and/or mean absolute deviation), as well as describing any overall pattern and any striking deviations from the overall pattern with reference to the context in which the data were gathered.
  - d. Relating the choice of measures of center and variability to the shape of the data distribution and the context in which the data were gathered.
- SP.6 Understand that statistics can be used to gain information about a population by examining a sample of the population; generalizations about a population from a sample are valid only if the sample is representative of that population. Understand that random sampling tends to produce representative samples and support valid inferences.
- SP.7 Use data from a random sample to draw inferences about a population with an unknown characteristic of interest. Generate multiple samples (or simulated samples) of the same size to gauge the variation in estimates or predictions. *For example, estimate the mean word length in a book by randomly sampling words from the book; predict the winner of a school election based on randomly sampled survey data. Gauge how far off the estimate or prediction might be.*
- SP.8 Use measures of center and measures of variability for numerical data from random samples to draw informal comparative inferences about two populations. *For example, decide whether the words in a chapter of a seventh-grade science book are generally longer than the words in a chapter of a fourth-grade science book.*
- SP.9 Understand that the probability of a chance event is a number between 0 and 1 that expresses the likelihood of the event occurring. Larger numbers indicate greater likelihood. A probability near 0 indicates an unlikely event, a probability around  $\frac{1}{2}$  indicates an event that is neither unlikely nor likely, and a probability near 1 indicates a likely event.

- SP.10 Approximate the probability of a chance event by collecting data on the chance process that produces it and observing its long-run relative frequency, and predict the approximate relative frequency given the probability. *For example, when rolling a number cube 600 times, predict that a 3 or 6 would be rolled roughly 200 times, but probably not exactly 200 times.*
- SP.11 Develop a probability model and use it to find probabilities of events. Compare probabilities from a model to observed frequencies; if the agreement is not good, explain possible sources of the discrepancy.
  - a. Develop a uniform probability model by assigning equal probability to all outcomes, and use the model to determine probabilities of events. *For example, if a student is selected at random from a class, find the probability that Jane will be selected and the probability that a girl will be selected.*
  - b. Develop a probability model (which may not be uniform) by observing frequencies in data generated from a chance process. *For example, find the approximate probability that a spinning penny will land heads up or that a tossed paper cup will land open-end down. Do the outcomes for the spinning penny appear to be equally likely based on the observed frequencies?*
- SP.12 Find probabilities of compound events using organized lists, tables, tree diagrams, and simulation.
  - a. Understand that, just as with simple events, the probability of a compound event is the fraction of outcomes in the sample space for which the compound event occurs.
  - b. Represent sample spaces for compound events using methods such as organized lists, tables and tree diagrams. For an event described in everyday language (e.g., “rolling double sixes”), identify the outcomes in the sample space which compose the event.
  - c. Design and use a simulation to generate frequencies for compound events. *For example, use random digits as a simulation tool to approximate the answer to the question: If 40% of donors have type A blood, what is the probability that it will take at least 4 donors to find one with type A blood?*
- SP.16 Construct and interpret a two-way table summarizing data on two categorical variables collected from the same subjects.

### Prior Scaffolding Knowledge / Skills:

---

- Understand the concept of a ratio and use ratio language to describe a ratio relationship between two quantities. *For example, “The ratio of wings to beaks in the bird house at the zoo was 2:1, because for every 2 wings there was 1 beak.” “For every vote candidate A received, candidate C received nearly three votes.”*
- Find a percent of a quantity as a rate per 100 (e.g., 30% of a quantity means  $\frac{30}{100}$  times the quantity); solve problems involving finding the whole, given a part and the percent.
- Apply and extend previous understandings of addition and subtraction to add and subtract rational numbers; represent addition and subtraction on a horizontal or vertical number line diagram.
- Solve real-world and mathematical problems involving the four operations with rational numbers.

### Lesson Progression Overview:

Lesson Big Idea	Lesson Details	Content Standards	Process Readiness Indicators
<b>Lesson 1: Entry Event: A Case of Gender Discrimination</b>	Students are introduced to the “Discrimination or Not?” scenario and asked to create 3 two-way tables: one that shows no discrimination, one that shows clear discrimination, and one in the gray area. Students then calculate simple probabilities in the gender discrimination problem and in other given scenarios.	SP.9 SP.16	PRI 1 PRI 3 PRI 4
<b>Lesson 2: Theoretical vs. Experimental Probability</b>	In this lesson, students distinguish between theoretical and experimental probabilities. Students will see how probabilities can be estimated when there is no theoretical probability.	SP.9 SP.11	PRI 1 PRI 2 PRI 7
<b>Lesson 3: Calculating Probabilities of Compound Events</b>	Students will examine compound events and calculate their probabilities beginning with using a tree diagram to organize outcomes and then later moving to a formula.	SP.12	PRI 2 PRI 3 PRI 4 PRI 9 PRI 10
<b>Lesson 4: Using Simulation to Estimate the Probabilities of Events</b>	Students will develop proportional reasoning skills by comparing quantities, looking at the relative ways numbers change, and thinking about proportional relationships in linear functions.	SP.7 SP.10	PRI 1 PRI 2 PRI 3 PRI 5
<b>Lesson 5: Formative Assessment Lesson: Evaluating Statements about Probability</b>	Students will estimate the probabilities of events by performing simulations using a variety of tools.	SP	PRI 1 PRI 3 PRI 4 PRI 6 PRI 7 PRI 9 PRI 10
<b>Lesson 6: Statistical Questions</b>	Students learn how to recognize a statistical question and must be able to justify their reasoning for why a question is or is not a statistical one. For questions that do not anticipate variability in the answers, students will rewrite the questions to make each statistical	SP.1 SP.2	PRI 1 PRI 3
<b>Lesson 7: Summarizing and Describing Distributions</b>	In this lesson, students will analyze a set of univariate data given a dot plot and box plot. Students will select and calculate appropriate measures of center and variability and will communicate about the distributions orally and in writing.	SP.3 SP.4 SP.5	PRI 1 PRI 3 PRI 6
<b>Lesson 8: The Effects of Outliers on a Summary Statistics</b>	Students will build on the previous lesson by creating a human box plot based on classroom data. Students will analyze the distribution and study the effects of outliers on measures of center and variability.	SP.3 SP.4 SP.5	PRI 1 PRI 2 PRI 3 PRI 4 PRI 5

Lesson Big Idea	Lesson Details	Content Standards	Process Readiness Indicators
<b>Lesson 9: Random Sampling</b>	Students will collect data on random samples in order to draw inferences about a population.	SP.6 SP.7	PRI 1 PRI 3 PRI 6 PRI 7 PRI 10
<b>Lesson 10: Formative Assessment Lesson: Comparing Data Using Statistical Measures</b>	This lesson unit is intended to help students to make meaningful comparisons between sets of data. In particular, students will develop their abilities to select appropriate measures of center and variability in order to summarize the important features of a set of data and use quantitative measures to justify an argument.	SP	PRI 1 PRI 2 PRI 3 PRI 4 PRI 5 PRI 6 PRI 7 PRI 8 PRI 9 PRI 10
<b>Lesson 11: A Simulation of Gender Discrimination</b>	Students will conduct a simulation to make an informed decision about the gender discrimination problem. After creating a dot plot of the simulation data, students will analyze the data and interpret the results. This culminating activity will require students to communicate their interpretation of the results using appropriate statistical language.	SP.4 SP.5 SP.6 SP.7 SP.9	PRI 1 PRI 3 PRI 4 PRI 6 PRI 7

Not Review Copy  
For Distribution

## Probability and One-Variable Statistics

# Lesson 1 of 11

## Entry Event: A Case of Gender Discrimination?

### Description:

---

Students are introduced to the “Discrimination or Not?” scenario and asked to create three two-way tables: one that shows no discrimination, one that shows clear discrimination, and one in the gray area. Students then calculate simple probabilities in the gender discrimination problem and in other given scenarios.

### College- and Career-Readiness Standards Addressed:

---

- SP.9 Understand that the probability of a chance event is a number between 0 and 1 that expresses the likelihood of the event occurring. Larger numbers indicate greater likelihood. A probability near 0 indicates an unlikely event, a probability around  $\frac{1}{2}$  indicates an event that is neither unlikely nor likely, and a probability near 1 indicates a likely event.
- SP.16 Construct and interpret a two-way table summarizing data on two categorical variables collected from the same subjects. Use relative frequencies calculated for rows or columns to describe possible association between the two variables.

### Process Readiness Indicator(s) Emphasized:

---

- PRI 1: Make sense of problems and persevere in solving through reasoning and exploration.
- PRI 3: Describe and justify mathematical understandings by constructing viable arguments, critiquing the reasoning of others and engaging in meaningful mathematical discourse.
- PRI 4: Contextualize mathematical ideas by connecting them to real-world situations. Model with mathematics.

Sequence of  
Instruction

Activities Checklist

## Engage

### PRI 3

Begin this lesson with a review of some key vocabulary in which students should have already been exposed. Ask students to turn to an elbow partner and discuss their mathematical understanding of each vocabulary word:

- Variability
- Two-way table
- Probability
- Random

Before presenting students with the entry event, make sure students have a solid understanding of these terms.

*Teacher's Note: The following activity has been adapted from Navigating through Data Analysis in Grades 9-12 by NCTM (2003).*

Present students with the following scenario:

Researchers conducted a study in which 48 male bank supervisors were each randomly assigned a personnel file and asked to judge whether the person should be promoted to a branch manager job that was described as “routine” or whether the person’s file should be held and other applicants interviewed. The files were all identical except that half of the supervisors had files labeled “male” while the other half had files labeled “female”. Of the 48 files reviewed, 35 were recommended for promotion.

Ask students:

- If you knew the numbers of “male” and “female” folders selected for promotion, and the selected “male” folders outnumbered the selected “female” folders, could you conclude that discrimination against women played a role in the bank supervisors’ recommendations?

Allow students 3-4 minutes to discuss the question in small groups of 2-3. Engage students in a whole-group discussion allowing each group to share their argument.

## Explore

### PRI 1

### PRI 3

### PRI 4

*Teacher's Note: Although we don't yet know how many of the 35 recommended for promotion are male and how many are female, we know that examining the information will either lead us to conclude: a) that there is no evidence of discrimination, b) there is strong evidence of discrimination, or c) that there is not enough evidence to say one way or another.*

Distribute Task #1: Fair Promotions? from the Student Manual.

INCLUDED IN THE STUDENT MANUAL

**Task #1: Fair Promotions?**

Researchers conducted a study in which 48 male bank supervisors were each randomly assigned a personnel file and asked to judge whether the person should be promoted to a branch manager job that was described as “routine” or whether the person’s file should be held and other applicants interviewed. The files were all identical except that half of the supervisors had files labeled “male” while the other half had files labeled “female”. Of the 48 files reviewed, 35 were recommended for promotion.

**DIRECTIONS:** Complete the tables by selecting numbers that would show no gender discrimination, strong evidence of gender discrimination, or not enough evidence to determine gender discrimination.

**No Discrimination by Gender**

	Recommended for Promotion	Not Recommended for Promotion	Total
Male			24
Female			24
Total	35	13	48

**Strong Evidence of Discrimination against Women**

	Recommended for Promotion	Not Recommended for Promotion	Total
Male			24
Female			24
Total	35	13	48

**Not Enough Evidence to Draw Conclusions**

	Recommended for Promotion	Not Recommended for Promotion	Total
Male			24
Female			24
Total	35	13	48



Explain to students that they will create three two-way tables representing the possible conclusions for the real world scenario mentioned above. In each of these two-way tables, the total for each row and column is already known, but students may need to be reminded of how a two-way table is created (i.e., the sum of males and females recommended for promotion must total 35 and the sum of males and females not recommended for promotion must total 13).

Instruct students to work individually to persevere in completing the three tables and then engage in meaningful mathematical discussion with group members to compare their responses. Circulate throughout the classroom looking for examples that would be good to share in the later whole-group discussion.

**No discrimination by gender:** If no gender discrimination took place, it is expected that the number of males and females promoted are fairly close. With 35 personnel recommended for promotion, this would mean 17 or 18 of these 35 would be male. Some students will feel comfortable taking these values to 16 or 19 but there is often uncertainty beyond this point.

**Strong evidence of discrimination against women:** Responses will likely vary widely in this table. If students are having trouble deciding, encourage them to examine all the possible numbers of males and females promoted with the corresponding percentages.

# and % of males promoted	17 49%	18 51%	19 54%	20 57%	...
# and % of females promoted	18 51%	17 49%	16 46%	15 43%	...

**Not enough evidence to draw conclusions:** Students will likely have a wide variety of values for this table as well. These will depend on the values from the previous two tables and represent the “gray” area of data.

For all three of these tables, there are not “right” answers. Rather, use these to generate a discussion on what students would consider to be strong evidence of gender discrimination and no evidence of gender discrimination.

After giving students sufficient time to create three two-way tables, ask some students to share their tables using a document camera (or writing on the board) in a whole-group discussion. Allow students to verbalize their mathematical thinking as they created the three scenarios. By looking at work from several students, the question of how much variability is “acceptable” should arise. If not, the following questions may be useful to generate those discussions and check for understanding.

Possible discussion questions:

- If the recommendations involved no discrimination, how many males would you expect to be recommended for promotion? How many females would you expect to be recommended for promotion?
- How much variability would you expect in a table that shows no evidence of discrimination? Is it likely that 19, 20, or even 21 men would be recommended?
- If the recommendations show strong evidence of discrimination against the women, how many males would you expect to be considered for promotion?
- How much variability would you expect in a table that shows strong evidence of discrimination?

*Teacher's Note: To assist with lesson 11, it is advised to take note of the variability students deem to be "acceptable" in the two-way table where no discrimination is practiced. This question of acceptable variability will be discussed in the culminating lesson.*

## Explanation

### PRI 3

Ask students to consider the two-way table below:

	Recommended for Promotion	Not Recommended for Promotion	Total
Male	21	3	24
Female	14	10	24
Total	35	13	48

Pose the question below and allow students a few minutes to engage in meaningful mathematical discourse in regards to these results in their groups:

- Now that you know more information about the results of the study, do you think there was discrimination by the bank supervisors against the females? How certain are you?

Reveal to students that these are the actual results from the discrimination study described at the beginning of class. Ask any students who feel there is no discrimination or that there is clear evidence of discrimination against women to share their thinking. Likewise, ask students who think there is not enough evidence to determine discrimination to share their thinking.

Explain to students these results fall somewhere in a "gray" area meaning that discrimination against the women cannot be determined from looking at the results alone. These results will be further investigated later in this unit. For now, students will calculate simple probabilities associated with these results.

Review the following vocabulary associated with calculating probabilities:

- Probability
- Event
- Outcome
- Sample Space

## Practice Individually

Instruct students to work individually to complete Task #2: Finding Probabilities in the Discrimination Study.

INCLUDED IN THE STUDENT MANUAL

### Task #2: Finding Probabilities in the Discrimination Study

#### Actual Results of the Discrimination Study

	Recommended for Promotion	Not Recommended for Promotion	<u>Total</u>
Male	21	3	24
Female	14	10	24
Total	35	13	<u>48</u>

1. What is the probability that a file selected represents a female recommended for promotion?

---

2. What is the probability that a file selected represents a male not recommended for promotion?

---

3. What percentage of files represents those not recommended for promotion?

---

4. Given a file recommended for promotion, what percentage was male?

---

5. What is the probability that a file not recommended for promotion is female?

---

6. Of the files representing women in the study, what percent were recommended for promotion?

---

**Task #2: Finding Probabilities in the Discrimination Study KEY**

**Actual Results of the Discrimination Study**

	Recommended for Promotion	Not Recommended for Promotion	Total
Male	21	3	24
Female	14	10	24
Total	35	13	<u>48</u>

1. What is the probability that a file selected represents a female recommended for promotion?

$$\frac{14}{48} = 29\%$$

2. What is the probability that a file selected represents a male not recommended for promotion?

$$\frac{3}{48} = 6.25\%$$

3. What percentage of files represents those not recommended for promotion?

$$\frac{13}{48} = 27\%$$

4. Given a file recommended for promotion, what percentage was male?

$$\frac{21}{35} = 60\%$$

5. What is the probability that a file not recommended for promotion is female?

$$\frac{10}{13} = 77\%$$

6. Of the files representing women in the study, what percent were recommended for promotion?

$$\frac{14}{24} = 58\%$$

As students work, identify some questions created by students to share in the closing activity. If students are struggling with this task, have some questions related to the discrimination study results on hand to use for the closing.

### Evaluate Understanding

#### PRI 1

Each student should individually complete Task #3: Lesson 1 - Exit Ticket for this lesson in the Student Manual.

INCLUDED IN THE STUDENT MANUAL

#### Task #3: Lesson 1 - Exit Ticket

One hundred people were surveyed about their use of smartphones. The results from the survey in the table below are incomplete. Complete the table and then answer the following questions:

##### Smartphone Use and Age

	Use Smartphone	Do Not Use Smartphone	Total
Under 40 Years of Age	40		45
40 Years of Age or Older			
Total		25	100

1. What is the probability that one of the people surveyed uses a smartphone?  
\_\_\_\_\_
2. What is the probability that one of the people surveyed was under 40 years of age and does not use a smartphone?  
\_\_\_\_\_
3. Given that a person surveyed is over 40 years old, what is the probability that person uses a smartphone?  
\_\_\_\_\_

**Task #3: Lesson 1 - Exit Ticket KEY**

One hundred people were surveyed about their use of smartphones. The results from the survey in the table below are incomplete. Complete the table and then answer the following questions:

**Smartphone Use and Age**

	Use Smartphone	Do Not Use Smartphone	<u>Total</u>
Under 40 Years of Age	40	5	45
40 Years of Age or Older	35	20	55
Total	75	25	<u>100</u>

1. What is the probability that a file selected represents a female recommended for promotion?

$$\frac{75}{100} = 75\%$$

2. What is the probability that a file selected represents a male not recommended for promotion?

$$\frac{5}{100} = 5\%$$

3. What percentage of files represents those not recommended for promotion?

$$\frac{35}{55} = 64\%$$

## Closing Activity

---

Display the actual discrimination results on the board and engage students in a whole-group discussion aimed at making sense of and summarizing the day's work.

Possible discussion questions:

- What assumptions, if any, did you make at the beginning of the lesson when you only knew 35/48 files reviewed were recommended for promotion?
- What results would clearly tell us that discrimination against women in this study took place? How do you know?
- What results clearly point to a lack of discrimination? How do you know?
- What factors must be considered when find probabilities in a two-way table?

To close, share some questions created by students (one at a time) for the whole class to consider. As mentioned earlier, have some questions on hand to use in case students are unable to generate good questions on their own.

*Note to teacher: This problem will be revisited in lesson 6 and 11. In lesson 6, students will be asked to create a statistical question appropriate to the given situation that will then be explored in lesson 11.*

## Resources/Instructional Materials Needed

---

- Task #1: Fair Promotions
- Task #2: Finding Probabilities in the Discrimination Study
- Task #3: Lesson 1 - Exit Ticket

## Probability and One-Variable Statistics

# Lesson 2 of 11

## Theoretical vs. Experimental Probability

### Description:

---

In this lesson, students distinguish between theoretical and experimental probabilities. Students will see how probabilities can be estimated when there is no theoretical probability.

### College- and Career-Readiness Standards Addressed:

---

- SP.9 Understand that the probability of a chance event is a number between 0 and 1 that expresses the likelihood of the event occurring. Larger numbers indicate greater likelihood. A probability near 0 indicates an unlikely event, a probability around  $\frac{1}{2}$  indicates an event that is neither unlikely nor likely, and a probability near 1 indicates a likely event.
- SP.11 Develop a probability model and use it to find probabilities of events. Compare probabilities from a model to observed frequencies; if the agreement is not good, explain possible sources of the discrepancy
  - a. Develop a uniform probability model by assigning equal probability to all outcomes, and use the model to determine probabilities of events. For example, if a student is selected at random from a class, find the probability that Jane will be selected and the probability that a girl will be selected.
  - b. Develop a probability model (which may not be uniform) by observing frequencies in data generated from a chance process. For example, find the approximate probability that a spinning penny will land heads up or that a tossed paper cup will land open-end down. Do the outcomes for the spinning penny appear to be equally likely based on the observed frequencies?

### Process Readiness Indicator(s) Emphasized:

---

- PRI 1: Make sense of problems and persevere in solving through reasoning and exploration.
- PRI 2: Reason abstractly and quantitatively by using multiple forms of representations to make sense of and understand mathematics.
- PRI 7: Look for and make use of patterns and structure.



Sequence of Instruction

Activities Checklist

Engage

PRI 1



Instruct students to read, make sense of the problem, and complete the opening exploration activity Task #4: Theoretical Probability Exploration. Students should persevere to complete this without assistance from the teacher. Encourage them to try their best. Circulate the room and take descriptive notes of student responses. (See answer key for sample responses).

INCLUDED IN THE STUDENT MANUAL

**Task #4: Theoretical Probability Exploration**

When you flip a fair coin, the theoretical probability of getting tails is 50% and the theoretical probability of getting a heads is 50%. These two outcomes are equally likely to occur.

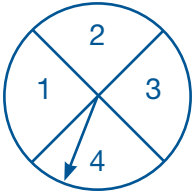
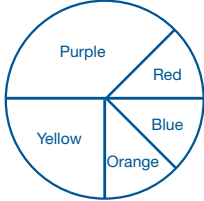

**DIRECTIONS:** Determine whether the outcomes in each experiment in the table are all equally likely to occur.

	Equally Likely	Not Equally Likely	Explanation
			
			
			
			

**Task #4: Theoretical Probability Exploration KEY**

When you flip a fair coin, the theoretical probability of getting tails is 50% and the theoretical probability of getting a heads is 50%. These two outcomes are equally likely to occur.

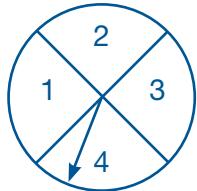
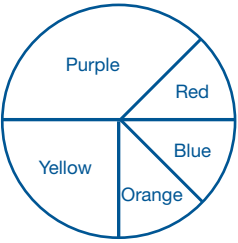
**DIRECTIONS:** Determine whether the outcomes in each experiment in the table are all equally likely to occur.

	Equally Likely	Not Equally Likely	Explanation
	X		There are six outcomes (numbers 1 through 6). Each has a probability of $\frac{1}{6}$ so the outcomes are equally likely.
	X		There are four outcomes each with the probability of $\frac{1}{4}$ assuming their areas are equivalent
		X	Because the areas for each space are not equivalent, the outcomes are not equally likely.
		X	Since the probability of drawing a white marble $\frac{6}{10}$ , a black marble $\frac{1}{10}$ , or a mixed marble $\frac{3}{10}$ are not equivalent, the outcomes are not equally likely.

**Whole group discussion:** When students are finished, facilitate a whole-group discussion based on student responses to the last column in the table. Use the descriptive notes that you took to guide the discussion.

**Explore**

**PRI 1**  
**PRI 2**  
**PRI 7**

*Teacher’s Notes: Prior to the lesson, set up five stations for students to complete the following activity. The resources needed for these stations include:*

- *Station 1: Coins*
- *Station 2: Dice*
- *Stations 3-5: Playing cards for each station*

*At each station, the teacher should have a piece of chart paper displayed where students can record their group data prior to switching stations.*

Divide the class into five equal groups. Explain each group will travel to each station with the What are My Chances? handout and will have 3-4 minutes to explore, look for patterns, and deepen their mathematical understanding of probability by completing the activity at each station. It is important each student complete all five experiments. This will give more data to use later in the lesson.

Explain that students will use the “What are My Chances Activity” in the Student Manual. *Teacher’s Note: The full activity can be found at <http://illuminations.nctm.org/uploadedFiles/Content/Lessons/Resources/6-8/WhatAreMyChances-AS.pdf>*

INCLUDED IN THE STUDENT MANUAL

**Task #5: What are My Chances Activity**

**What Are My Chances?**

NAME \_\_\_\_\_

You will be evaluating games of chance to help you understand probability. For each game of chance, predict what will be the most frequent outcome. Then run the experiment 10 times. For each trial, record the actual outcome in the Result row. If this matches your predicted outcome, put a check mark in the Prediction row.



1. Flip a Coin  
 Prediction for most frequent outcome: Heads Tails

RESULT									
PREDICTION									

2. Roll 1 Die  
 Prediction for most frequent outcome: 1 2 3 4 5 6

RESULT									
PREDICTION									

3. Pick a Card Color  
 Prediction for most frequent outcome: Red Black

RESULT									
PREDICTION									

4. Pick a Card Suit  
 Prediction for most frequent outcome: Clubs (♣) Spades (♠) Diamonds (♦) Hearts (♥)

RESULT									
PREDICTION									

5. Pick an Exact Card  
 Prediction for most frequent outcome: \_\_\_\_\_ (e.g., 3♥)

RESULT									
PREDICTION									

6. In which game of chance were your predictions most accurate?

7. Complete the table below with the probability for each event. Use the results from your experiments above to calculate the experimental probabilities.

GAME OF CHANCE	EVENT	EXPERIMENTAL PROBABILITY	THEORETICAL PROBABILITY
Flip a Coin	Heads		
Roll 1 Die	6		
Pick a Card Color	Red		
Pick a Card Suit	Diamonds		
Pick an Exact Card	5 of Diamonds		

8. Compare the theoretical and experimental probabilities for each game of chance. Were you close in any of the experiments?

9. Collect data from the entire class for the probability of an event matching the predicted event (Note: This works even if different groups predicted different outcomes.) Record the number of correctly predicted trials and the experimental probability of each. Since each group performed 10 trials for each game, the number of trials will be 10 × the number of groups.

GAME OF CHANCE	# OF CORRECT PREDICTIONS	EXPERIMENTAL PROBABILITY
Flip a Coin		
Roll 1 Die		
Pick a Card Color		
Pick a Card Suit		
Pick an Exact Card		

10. Are the experimental probability different in Questions 7 and 9? Why or why not?

11. How do the theoretical probabilities in Question 7 compare to the experimental probabilities in Question 9? What do you think would happen if even more trials were added?

**Whole Group Discussion:** When students finish the experiments in items 1–5 in the task, facilitate a whole-group discussion about their results and any observations they may have as a whole class. Since the sample sizes are only 10 for each experiment, many will most likely not match the theoretical probability very well. This is expected and will enrich the discussion later when students combine all the class data. Ask students:

- Did our experiments provide enough information to make accurate predictions?

Have students share their thinking as to what number of trials may be needed to get a sample that could better be used to predict outcomes. Students should determine that the sample size matters and, in this case, was too small.

To help students see when small numbers are not good predictors of large number results, ask students:

- Would it be fair to give a report card grade based on 1 test or 1 assignment?
- Would it be accurate to conclude that a coin will always come up heads after flipping it once?
- If 50% of students in a class said they like country music, do you think that means 50% of students in the whole school like country music?
- Could you assume that if a person throws a basketball once and makes a basket from half court, then they are a good shooter?

*Note to teacher: For each question above, ask students to justify their reasoning.*

Ask the following questions about the five experiments to help students see the need for more trials:

- If a coin is flipped 10 times, how many times would you expect to get heads?
- How often did your coin land on heads?
- Why do you believe these values are not the same?

*Note to teacher: If students are still struggling with these questions, continue by asking similar questions about the other experiments.*

Combining their experimental results with the questions above, the class should agree that only a few trials is not enough to make predictions. This should motivate students to decide that combining the entire class data together will probably show probabilities closer to the theoretical probabilities. Assign each of the five experiments to a different group. Using the chart paper with the class data, instruct students to calculate the probability for that experiment. Ask each group to present their findings and processes to the class.

## Explanation

### PRI 7

Discuss and make comparisons with the students about the patterns and structures of theoretical and experimental probability. With enough class data, experimental and theoretical probability should be close. It is possible that the results could still be far from the theoretical probability. If this arises, it should add to the discussion of the nature of probability. You never know what is going to happen with chance.

Possible discussion questions:

- What is the connection between theoretical and experimental probability?  
*(Experimental probability will get closer to theoretical probability as more trials are conducted. This is called the Law of Large Numbers.)*
- How could you explain the two types of probability to someone who has never heard of them?  
*(Experimental probability is the chance of an outcome based on a performed event or experiment. Theoretical probability is based on what could happen theoretically if the event is to be performed.)*
- Why is it useful to know about probabilities?  
*(We can use them to understand events and what outcomes are possible, as well as what outcomes are likely.)*

### Practice Together In Small Groups

The students will work within their groups to complete Task #6: Experimental and Theoretical Probability in the Student Manual.

Teacher's Note: This task can be found at <https://stsampsonshigh.files.wordpress.com/2014/02/experimental-prb-ws.pdf>

INCLUDED IN THE STUDENT MANUAL

## Task #6: Experimental and Theoretical Probability

**Probability Worksheet 4**  
 Experimental and Theoretical Probability

Name \_\_\_\_\_  
 Per \_\_\_\_\_ Date \_\_\_\_\_

**Amanda used a standard deck of 52 cards and selected a card at random. She recorded the suit of the card she picked, and then replaced the card. The results are in the table below.**

Diamonds	
Hearts	
Spades	
Clubs	

- Based on her results, what is the experimental probability of selecting a heart?
- What is the theoretical probability of selecting a heart?
- Based on her results, what is the experimental probability of selecting a diamond or a spade?
- What is the theoretical probability of selecting a diamond or a spade?
- Compare these results, and describe your findings.

6. Dale conducted a survey of the students in his classes to observe the distribution of eye color. The table shows the results of his survey.

Eye color	Blue	Brown	Green	Hazel
Number	12	58	2	8

- Find the experimental probability distribution for each eye color.  
 P (blue) = \_\_\_\_\_ P (brown) = \_\_\_\_\_ P (green) = \_\_\_\_\_ P (hazel) = \_\_\_\_\_
- Based on the survey, what is the experimental probability that a student in Dale's class has blue or green eyes?
- Based on the survey, what is the experimental probability that a student in Dale's class does not have green or hazel eyes?
- If the distribution of eye color in Dale's grade is similar to the distribution in his classes, about how many of the 360 students in his grade would be expected to have brown eyes?

p.1 Revised June 2010

**Probability Worksheet 4**

7. Your sock drawer is a mess! You just shove all of your socks in the drawer without worrying about finding matches. Your aunt asks how many pairs of each color you have. You know that you have 32 pairs of socks, or 64 individual socks in four different colors: white, blue, black, and tan. You do not want to count all of your socks, so you randomly pick 20 individual socks and predict the number from your results.

Color of sock	White	Blue	Black	Tan
Number of socks	12	1	3	4

A. Find the experimental probability of each:  
 P (white) = \_\_\_\_\_ P (blue) = \_\_\_\_\_ P (black) = \_\_\_\_\_ P (tan) = \_\_\_\_\_

B. Based on your experiment, how many socks of each color are in your drawer? Show your work!  
 White = \_\_\_\_\_ Blue = \_\_\_\_\_ Black = \_\_\_\_\_ Tan = \_\_\_\_\_

Based on your results, how many pairs of each sock are in your drawer?  
 White = \_\_\_\_\_ Blue = \_\_\_\_\_ Black = \_\_\_\_\_ Tan = \_\_\_\_\_

D. Your drawer actually contains 16 pairs of white socks, 2 pairs of blue socks, 6 pairs of black socks, and 8 pairs of white socks. How accurate was your prediction?

p.2 Revised June 2010

**Task #6 Experimental and Theoretical Probability KEY**

1.  $\frac{3}{10}$

2.  $\frac{1}{4}$

3.  $\frac{9}{26}$

4.  $\frac{1}{2}$

5. Answers will vary. Sample student answers may include that drawing cards is random and unpredictable and Amanda did not perform enough trials to achieve theoretical probability.

6. a.  $P(\text{blue}) = \frac{3}{20}$     $P(\text{brown}) = \frac{29}{40}$     $P(\text{green}) = \frac{1}{40}$     $P(\text{hazel}) = \frac{1}{10}$

b.  $\frac{7}{40}$

c.  $\frac{7}{8}$

d. 261

7. A.  $P(\text{white}) = \frac{3}{5}$     $P(\text{blue}) = \frac{1}{20}$     $P(\text{black}) = \frac{3}{20}$     $P(\text{tan}) = \frac{1}{5}$

*Note to teacher: When estimating the number of socks and pairs of socks in 7B and 7C using the answers from 7A, the students will arrive at decimal or fractional answers which don't make sense in the context of the number of socks. A discussion on rounding to a discrete number of socks could be necessary.*

B. White = 38   Blue = 3   Black = 10   Tan = 13

C. White = 19   Blue = 1 or 2   Black = 5   Tan 6 or 7

D. Answers will vary but should include discussion of the idea that random sampling is unpredictable and achieving numbers close to theoretical probability often requires a large sample size.

## Evaluate Understanding

Ask students to complete Task #7: Lesson 2 - Exit Ticket in the Student Manual. They may need reminding that there are many possible correct percentages; their explanation, however, is most important.

INCLUDED IN THE STUDENT MANUAL

### Task #7: Lesson 2 - Exit Ticket

In Jean's computer programming class she learns to program her computer to randomly change the background color to green, yellow, or red every minute. Provide percentages that represent the likelihood of a yellow background for each scenario.

1. Assume the chance of a getting a green, yellow, or red color is equally likely. What is the theoretical probability of getting a yellow background?

---



---

2. Complete the table by providing possible values of the number of yellow backgrounds from the given number of trials. Then, calculate the percentage for each number of trials and explain why you chose these numbers.

No. of Trials	No. of Yellow	Percent of Yellow	Explanation
10			
50			
200			
1,000			

### Task #7 Lesson 2 – Exit Ticket **KEY**

1. When all outcomes are equally likely, the chance of getting a yellow background is or  $33\frac{1}{3}\%$ .
2. Student answers will vary. Students will select a number of yellow for each number of trials in the table and then calculate the percent of yellow based on their choice.

### Closing Activity

---

Display the Adjustable Spinner tool at <http://illuminations.nctm.org/adjustablespinner/> on the board for all students to see. As you explore with your class, point out the experimental and theoretical probabilities as you spin multiple times. Ask students to share their observations and describe any patterns they noticed. Students should realize as the number of trials increases, the data percents will get closer to the theoretical probability. Explain to students that this idea is called “The Law of Large Numbers.” While this concept is not explicitly addressed by the standards, it is an appropriate extension to the lesson.

Ask students:

- What do you see on the adjustable spinner that is similar to our experiments we conducted in class?

Facilitate a whole-group discussion.

### Resources/Instructional Materials Needed

---

- Dice
- Coins
- Playing cards
- Task #4: Theoretical Probability Exploration
- Task #5: What are My Chances?
- Task #6: Experimental and Theoretical Probability
- Task #7: Lesson 2 - Exit Ticket
- Adjusted Spinner applet <http://illuminations.nctm.org/adjustablespinner/> (Date accessed: June 7, 2015)



## Probability and One-Variable Statistics

# Lesson 3 of 11

## Calculating Probabilities of Compound Events

### Description:

---

Students will examine compound events and calculate their probabilities beginning with using a tree diagram to organize outcomes and then later moving to a formula.

### College- and Career-Readiness Standards Addressed:

---

- SP.12 Find probabilities of compound events using organized lists, tables, tree diagrams, and simulation.
  - a. Understand that, just as with simple events, the probability of a compound event is the fraction of outcomes in the sample space for which the compound event occurs.
  - b. Represent sample spaces for compound events using methods such as organized lists, tables and tree diagrams. For an event described in everyday language (e.g., “rolling double sixes”), identify the outcomes in the sample space which compose the event.

### Process Readiness Indicator(s) Emphasized:

---

- PRI 2: Reason abstractly and quantitatively by using multiple forms of representations to make sense of and understand mathematics.
- PRI 3: Describe and justify mathematical understandings by constructing viable arguments, critiquing the reasoning of others and engaging in meaningful mathematical discourse.
- PRI 4: Contextualize mathematical ideas by connecting them to real-world situations. Model with mathematics.
- PRI 9: Demonstrate flexible use of strategies and methods while reflecting on which procedures seem to work best for specific types of problems.
- PRI 10: Reflect on mistakes and misconceptions to improve mathematical understanding.

### Engage

Allow students 3 minutes to complete the first two columns of the KWL chart in the Student Manual. Monitor what students write during this time and take notes about student responses. Facilitate a whole-group discussion using students' examples. For example, have a student that knows something about compound events respond to another student that wants to learn the same thing about compound events. Create a classroom KWL chart with student responses on the board/chart paper.

INCLUDED IN THE STUDENT MANUAL

#### Task #8: KWL

Name: \_\_\_\_\_ Date: \_\_\_\_\_ Period: \_\_\_\_\_

Today I will learn....

What I KNOW About Compound Events	What I WANT to know about Compound Events	What I LEARNED About Compound Events
What is a <i>compound</i> ?  Where do I see or use <i>compounds</i> in real life?		

Review vocabulary of previous lesson

- Theoretical probability
- Experimental probability
- Simple event

Introduce new vocabulary:

- Compound event
- Sample space
- Independent events
- Dependent events
- Complement

## Explore

PRI 2  
PRI 4  
PRI 9

Instruct students to find Task #9: Ice Cream Shop in the Student Manual. Allow students 5-10 minutes to reason through and complete the problem.

INCLUDED IN THE STUDENT MANUAL

### Task #9: Ice Cream Shop

When you go to get ice cream with friends there are many choices for you to make. What flavor ice cream, what kind of topping you want, and what color sprinkles. How many different sundaes can you make when you order one flavor of ice cream, one topping, and one color of sprinkles from the chart below?

Ice Cream Flavor	Topping	Sprinkles
Chocolate	Fudge	Chocolate
Vanilla	Marshmallow	Rainbow
Strawberry		

1. Show all the possible outcomes in a **tree diagram**.

2. Use the tree diagram to list the **Sample Space** of all possible ice cream sundaes.

**Sample Space**

3. Use the information above to calculate the following probabilities.

a.  $P(\text{Chocolate Ice Cream}) = \underline{\hspace{2cm}}$       b.  $P(\text{Vanilla Ice Cream}) = \underline{\hspace{2cm}}$

$P(\text{Fudge}) = \underline{\hspace{2cm}}$        $P(\text{Rainbow}) = \underline{\hspace{2cm}}$

$P(\text{Chocolate Ice Cream and Fudge}) = \underline{\hspace{2cm}}$        $P(\text{Vanilla Ice Cream and Rainbow}) = \underline{\hspace{2cm}}$

c.  $P(\text{Chocolate Ice Cream and Fudge and Rainbow}) = \underline{\hspace{2cm}}$

d.  $P(\text{Vanilla Ice Cream or Strawberry Ice Cream}) = \underline{\hspace{2cm}}$

4. Create an example of a simple event.

5. Create an example of a compound event.

*\*Adapted from Ice Cream Shop at  
[https://ilearn.marist.edu/access/content/user/10026480@marist.edu/edTPA/Lesson%20Plan%20\\_2.pdf](https://ilearn.marist.edu/access/content/user/10026480@marist.edu/edTPA/Lesson%20Plan%20_2.pdf)*

**Task #9: Ice Cream Shop KEY**

1. Tree Diagram



2. Sample Space

- chocolate, fudge, chocolate
- chocolate, fudge, rainbow
- chocolate, marshmallow, chocolate
- chocolate, marshmallow, rainbow
- vanilla, fudge, chocolate
- vanilla, fudge, rainbow
- vanilla, marshmallow, chocolate
- vanilla, marshmallow, rainbow
- strawberry, fudge, chocolate
- strawberry, fudge, rainbow
- strawberry, marshmallow, chocolate
- strawberry, marshmallow, rainbow

3. a.  $P(\text{Chocolate Ice Cream}) = \frac{1}{3}$                       b.  $P(\text{Vanilla Ice Cream}) = \frac{1}{3}$   
     $P(\text{Fudge}) = \frac{1}{2}$      $P(\text{Rainbow}) = \frac{1}{2}$   
     $P(\text{Chocolate Ice Cream and Fudge}) = \frac{1}{6}$        $P(\text{Vanilla Ice Cream and Rainbow}) = \frac{1}{6}$   
    c.  $P(\text{Chocolate Ice Cream and Fudge and Rainbow}) = \frac{1}{12}$   
    d.  $P(\text{Vanilla Ice Cream or Strawberry Ice Cream}) = \frac{2}{3}$
4. Answers will vary.
5. Answers will vary.

Group students in pairs. Explain that students will complete a structured think-pair-share.

**Rules for Think-Pair-Share:**

- First student will get 60-90 seconds to discuss the method or strategy they chose and how they came to their answers.
- Second student will get 30 seconds more than student one. Second student must start their turn by acknowledging something the first student explained. Next, student two will have 60-90 seconds to discuss the method they chose and how they came to their answers.
- Both students will now get 90-120 seconds to ask and answer any questions the other student may have about the method and reasoning.

*Teacher's Notes: While the students are involved in the Think-Pair-Share, take notes on methods students are using. It would be best to pair students together that used different methods to facilitate mathematical conversations about why students chose certain methods.*

Give students no more than 5 minutes to work collaboratively to take their work and make it better. Students must decide which strategy they would like to use and apply to the example.

**Explanation**

**PRI 3**  
**PRI 4**  
**PRI 10**

Select several groups that used different strategies to describe which method they selected and how they applied it to complete the task. Scaffold the presentations from lowest level to highest to help students see the progression of learning toward grade-level strategies.

Once students present, ensure understanding by reviewing each strategy the students presented. Clear up any misconceptions to ensure they hear the correct mathematical reasoning for each strategy. Connect for the students that they can multiply the probabilities together to find the compound probabilities.

*Teacher's Notes: Dependent and independent events must be explained. Students will model with mathematics by using methods such as lists and tree diagrams. These*

are fine. They need to be related back to how it works mathematically. These are great visual representations and a way to scaffold how the math works.

### Practice Together In Teams

Have students complete Task #10: Rolling Twice adapted from <https://www.illustrativemathematics.org/content-standards/tasks/890>.

INCLUDED IN THE STUDENT MANUAL

#### Task #10: Rolling Twice

A fair six-sided die is rolled twice. What is the theoretical probability that the first number that comes up is greater than or equal to the second number?

#### Task #10: Rolling Twice **KEY**

One Possible Solution is included here. Additional solution methods can be found at <https://www.illustrativemathematics.org/content-standards/7/SP/C/8/tasks/890>.

#### Solution: 1 Plotting outcomes in a table

We can plot the different possible outcomes as the six sided die is rolled. One way of doing this is with a table as shown below.

1,1*	1,2	1,3	1,4	1,5	1,6
2,1*	2,2*	2,3	2,4	2,5	2,6
3,1*	3,2*	3,3*	3,4	3,5	3,6
4,1*	4,2*	4,3*	4,4*	4,5	4,6
5,1*	5,2*	5,3*	5,4*	5,5*	5,6
6,1*	6,2*	6,3*	6,4*	6,5*	6,6*

In the table the entry marked 1,3 means that the first throw was a 1 and the second throw a 3. An asterisk next to the entry means that the first number that came up is greater than or equal to the second number. There are 36 possibilities listed in the table, each equally likely. For the 21 starred cases, the first number was greater than or equal to the second number. So the probability that the first number is greater than or equal to the second number is  $\frac{21}{36} = \frac{7}{12}$ .

**Evaluate Understanding**

Instruct students to complete the Task #11: Lesson 3 - Exit Ticket for this lesson in the Student Manual. Assess students' responses for mastery.

INCLUDED IN THE STUDENT MANUAL

**Task #11: Lesson 3 - Exit Ticket**

- A hotel building has 10 floors; each floor has three different types of rooms (Family suite, Superior suite, and Deluxe suite). Carrie made a spinner as a probability model for randomly choosing one hotel room. Carrie spins both spinners below.

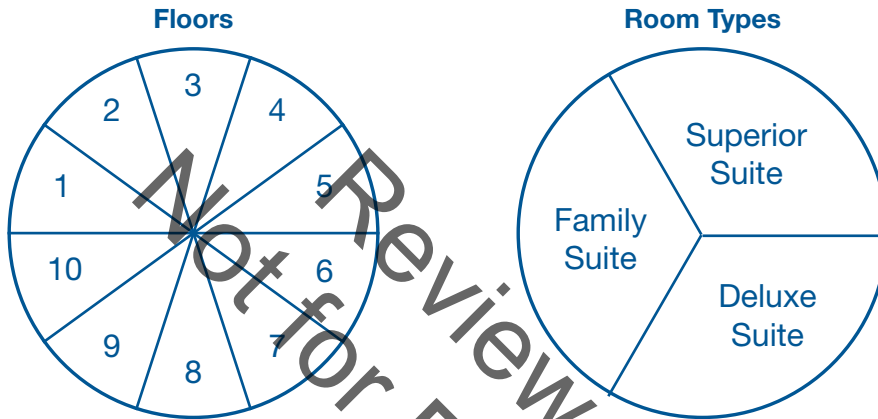

- What is the probability that she chooses the family suite that's above the 8th floor?  
 Fraction: \_\_\_\_\_ Decimal: \_\_\_\_\_ Percent: \_\_\_\_\_
- What is the probability that she chooses the Superior Suite below the 5th floor?  
 Fraction: \_\_\_\_\_ Decimal: \_\_\_\_\_ Percent: \_\_\_\_\_

- Create a simulation of a compound event. Describe in words. You may also need to draw a picture. Then create two problems about compound probability using your simulation. Be sure to provide answer key and justify your reasoning for each problem. (HINT: Possible simulation options include spinners, dice, and coins.)

Simulation	Problem 1	Problem 2



**Task #11: Lesson 3 - Exit Ticket KEY**

1. A hotel building has 10 floors; each floor has three different types of rooms (Family suite, Superior suite, and Deluxe suite). Carrie made a spinner as a probability model for randomly choosing one hotel room. Carrie spins both spinners below.

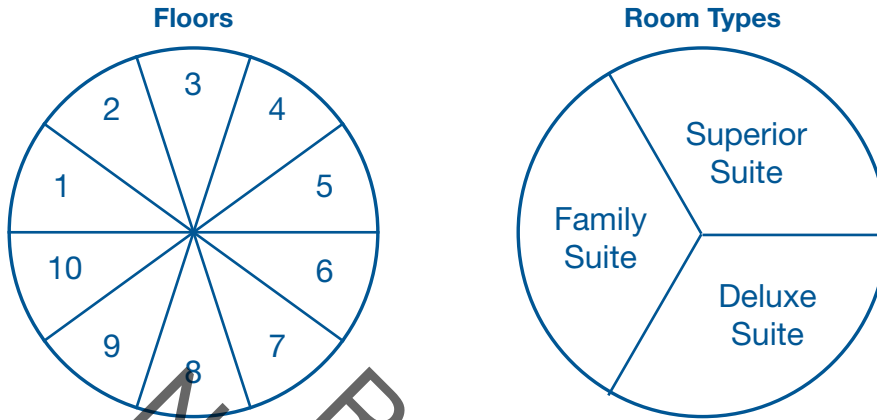

- a. What is the probability that she chooses the family suite that's above the 8th floor?

Fraction:  $\frac{1}{15}$  Decimal: 0.06 Percent: 7%

- b. What is the probability that she chooses the Superior Suite below the 5th floor?

Fraction:  $\frac{2}{15}$  Decimal: 0.13 Percent: 13%

## Closing Activity

---

Revisit the KWL chart in the Student Manual. Ask students to spend a few minutes individually completing the “What I have Learned” column. Facilitate a whole-group discussion. Address items in the “What I Want to Learn” column that were not addressed during the lesson.

## Resources/Instructional Materials Needed

---

- Task #8: KWL
- Task #9: Ice Cream Shop
- Task #10: Rolling Twice
- Task #11: Lesson 3 - Exit Ticket

Review Copy  
Not for Distribution

## Probability and One-Variable Statistics

# Lesson 4 of 11

## Using Simulation to Estimate the Probabilities of Events

### Description:

---

Students will estimate the probabilities of events by performing simulations using a variety of tools.

### College- and Career-Readiness Standards Addressed:

---

- SP.7 Use data from a random sample to draw inferences about a population with an unknown characteristic of interest. Generate multiple samples (or simulated samples) of the same size to gauge the variation in estimates or predictions. *For example, estimate the mean word length in a book by randomly sampling words from the book; predict the winner of a school election based on randomly sampled survey data. Gauge how far off the estimate or prediction might be.*
- SP.10 Approximate the probability of a chance event by collecting data on the chance process that produces it and observing its long-run relative frequency, and predict the approximate relative frequency given the probability.

### Process Readiness Indicator(s) Emphasized:

---

- PRI 1: Make sense of problems and persevere in solving through reasoning and exploration.
- PRI 2: Reason abstractly and quantitatively by using multiple forms of representations to make sense of and understand mathematics.
- PRI 3: Describe and justify mathematical understanding by constructing viable arguments, critiquing the reasoning of others and engaging in meaningful mathematical discourse.
- PRI 5. Use appropriate tools strategically to support thinking and problem solving.

Sequence of Instruction

Activities Checklist

Engage

PRI 1

Play the Act 1 video clip of “Yellow Starbursts,” a Three Act Task by Dan Meyer that can be found at <http://threeacts.mrmeyer.com/yellowstarbursts/>.

Group students in pairs to explore and reason through this scenario. Ask students to engage in a Think-Pair-Share about the first two questions on Task #12: Yellow Starbursts, Act 1 in the Student Manual.

INCLUDED IN THE STUDENT MANUAL

**Task #12: Yellow Starbursts Act 1**

*Adapted from Andrew Stadel*

**ACT 1**

What did/do you notice?

\_\_\_\_\_

\_\_\_\_\_

\_\_\_\_\_

What questions come to your mind?

\_\_\_\_\_

\_\_\_\_\_

\_\_\_\_\_

Main Question:

\_\_\_\_\_

\_\_\_\_\_

\_\_\_\_\_

Estimate the result of the main question. Explain.

\_\_\_\_\_

\_\_\_\_\_

\_\_\_\_\_

Place an estimate that is too high and too low on the number line



Low estimate

Place an “x” where your estimate belongs

High estimate

- What did you notice?
- What questions come to mind?

*Teacher's Note: Directions for Think-Pair-Share.*

- *Think to yourself for one minute about the first two questions on the recording sheet and jot down any ideas you have.*
- *Turn to your partner and share your thoughts about those first two questions.*
- *Share any questions in a whole-group discussion.*

Facilitate a whole-class discussion about the two questions. Record student responses on the board or chart paper. Ask the class to decide on a question they wish to pursue. Possible questions include:

- How many packs have one yellow Starburst?
- How many packs have two yellow Starbursts?

After the class reaches a consensus on a main question, instruct students to write this main question on the Task #12: Yellow Starbursts, Act 1.

Ask students to estimate an answer to the question that is too high and one that is too low. Record student guesses on the board or chart paper.

## Explore

### PRI 2

Now instruct students to proceed to Task #13: Yellow Starbursts, Acts 2 & 3. Ask students:

INCLUDED IN THE STUDENT MANUAL

#### Task #13: Yellow Starbursts, Acts 2 & 3

##### ACT 2

What information would you like to know or do you need to solve the MAIN question?

---

---

Record the given information (measurements, materials, etc....)

---

If possible, give a better estimate using this information:

---

Use this area for your work, tables, calculations, sketches, and final solution.

### ACT 3

What was the result?

---

---

---

Which Process Readiness Indicators did you use?

- Make sense of problems and persevere in solving through reasoning and exploration.
- Attend to precision.
- Reason abstractly and quantitatively by using multiple forms of representations to make sense of and understand mathematics.
- Look for and make use of patterns and structure.
- Describe and justify mathematical understandings by constructing viable arguments, critiquing the reasoning of others and engaging in meaningful mathematical discourse.
- Look for and express regularity in repeated reasoning.
- Contextualize mathematical ideas by connecting them to real-world situations. Model with mathematics.
- Demonstrate flexible use of strategies and methods while reflecting on which procedures seem to work best for specific types of problems.
- Use appropriate tools strategically to support thinking and problem solving.
- Reflect on mistakes and misconceptions to improve mathematical understanding.

- What information will you need to answer the question?

Allow students 3-5 minutes to brainstorm individually to make sense of this question. Then allow them 2 minutes to discuss with their partner. Students should record their lists in Task #13: Yellow Starbursts, Acts 2 & 3 in the Student Manual. Ask groups to share with the class the information they think they need to answer the main question. Record student responses on the board or chart paper.

*Teacher's Note: It is important for students to know that the Starburst packs contain four possible colors and that there are exactly 287 packs, but give students ample time to realize this before showing the following images:*

- *The possible Starburst colors*
- *The exact number of Starburst packs*
- *The frequency of Starburst colors*

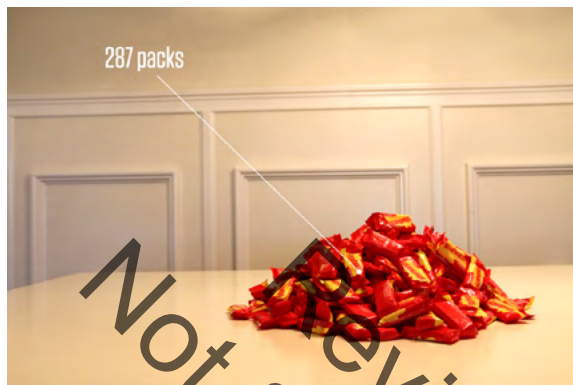

### Explanation

#### PRI 3

After students have had sufficient time to work toward a solution, select several groups to share their work. Then, engage the students in meaningful mathematical discussion regarding the solutions shared. Show the Act 3 video with the answer, which can be found at <http://threeacts.mrmeyer.com/yellowstarbursts/>, and the image that displays the frequency of every possible pair.

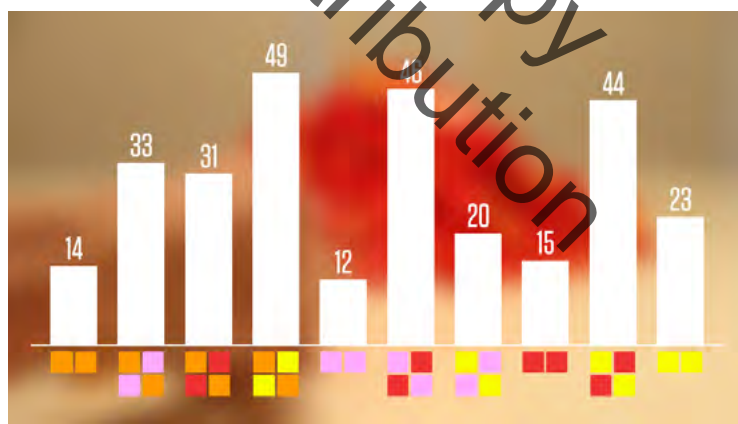

Ask students to compare their initial guesses to the actual answer.

### Practice Together in Small Groups

#### PRI 5

*Teacher's Note: In this exploration, students will use an appropriate tool to simulate opening Starburst candies. To simulate the Starburst experiment, students will ideally use two spinners divided into four equal sections with the Starburst candy colors: yellow, pink, red, and orange. If spinners are not available, students can virtually simulate a spinner using the Probability Simulation App on the TI-84 graphing calculator, by using an online interactive spinner, or by using a probability simulator app on a tablet*

or smart phone. There are many options available. In the absence of any type of real or virtual spinner, four or six sided die could also be used, assigning each numbered side one of the Starburst colors. On the six sided die, two of the sides could be assigned as “roll again” sides. Another alternative would be to provide each group with some Starburst packs of two in order to have a total of 20 trials as a class.

Create groups of 2-4 students. Instruct students to find the Task #14: Starburst Simulation in the Student Manual. Each student should record the simulation results for his/her group. Each group should complete at least 20 trials. When the student groups have concluded their data collection, discuss their results, and compile the class data collected for zero, one, and two yellow Starbursts and post this in the classroom.

INCLUDED IN THE STUDENT MANUAL

**Task #14: Starburst Simulation**

Using the simulator provided by your teacher (spinner, die, virtual spinner), complete 20 trials by “opening” two packs of Starburst candies and record the colors in the chart below. Then find a total for the number of 0, 1, and 2 yellow Starburst combinations.

Trial	Starburst #1 Color	Starburst #2 Color
1		
2		
3		
4		
5		
6		
7		
8		
9		
10		
11		
12		
13		
14		
15		
16		
17		
18		
19		
20		



1. How many times did you get 0 yellow Starbursts?

---

2. How many times did you get 1 yellow Starburst?

---

3. How many times did you get 2 yellow Starbursts?

---

4. How do your initial guesses compare to the actual answers?

---

---

---

5. How did the class simulation data compare to the answers provided in the video?

---

---

---

---

6. How might the information gained from this experiment be useful to a consumer who does or does not like yellow Starburst?

---

---

---

---

---

---

---

---

---

---

---

---

---

Not for Review Copy  
Distribution

## Evaluate Understanding

Display the image from Act 3 again that shows the frequency of every possible pair.

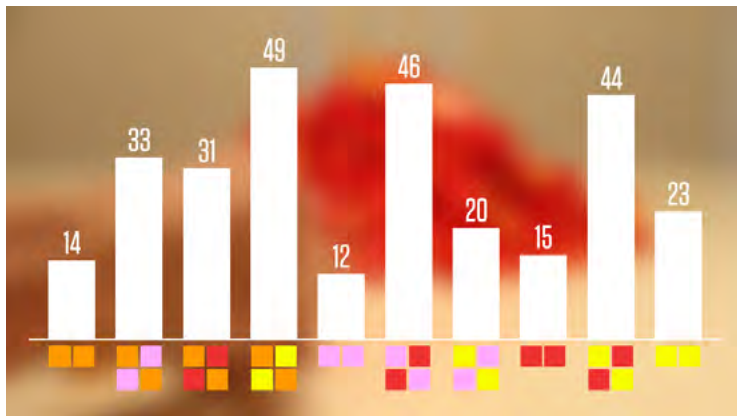

Ask the students:

- How did the class simulation data compare to the answers provided in the video?
- How might the information gained from this experiment be useful to a consumer who does or does not like yellow Starburst?

## Closing Activity

Display the Frequency of Starburst Colors Image from Act 2 again along with the question below.



To formatively assess for understanding, ask students to answer the question and turn in as an exit ticket:

- If pink is my favorite Starburst, in a mountain of 250 packs of Starburst, how many pink Starbursts would you expect to find? How would you find the answer? ( $250 \times 0.21 = 52.5$ )

## Independent Practice

- “Probability Practice” in the Student Manual

INCLUDED IN THE STUDENT MANUAL

**Task #15: Probability Practice**

**DIRECTIONS:** Answer the questions below. Use words, calculations, and/or diagrams to justify your reasoning.

1. How many times would one expect to get “heads” if a fair coin was tossed 26 times?  
\_\_\_\_\_
2. About how many times would a number greater than 4 come up if a 6 sided number cube was rolled 20 times?  
\_\_\_\_\_
3. If 16 cards were randomly pulled from a standard deck of playing cards, about how many would be spades? A red card?  
\_\_\_\_\_
4. A bag contains 5 green marbles, 7 blue marbles, and some black marbles. The probability of drawing a green marble is 25%. How many black marbles are in the bag?  
\_\_\_\_\_
5. John caught 15 fish last weekend, 10 of which were too small to keep. If John wants to keep 7 fish today, about how many should he try to catch?  
\_\_\_\_\_

Answers:

1. The theoretical probability of “heads” on a coin flip is 50%, so one would expect to get **13 “heads”** on **26 flips**.
2. There are 2 sides greater than 4 on the six sided number cube or  $\frac{1}{3}$  chance.

For 20 rolls, a number greater than 4 would come up **about 7 times**.

3. Twenty-five percent of a standard deck of cards are spades, so from 16 random cards, **about 4 should be spades**. Half the cards are red, **so 8 should be red**.
4. There are 5 green marbles in the bag. The probability of selecting a green marble at random is 25%. This means 5 divided by the total number of marbles in the bag is 0.25. Solving:

$$\frac{5}{x} = 0.25$$

gives us the total number of marbles in the bag, 20. Subtracting 5 green and 7 blue marbles from the 20 leaves **8 black marbles**.

5. If John had to throw back 10 fish out of 15, he kept 5 out of 15, or one-third of the fish caught. So, he would need to **catch 21 fish** to have 7 keepers.

### Resources/Instructional Materials Needed:

---

- Computer
- Projector
- 2 spinners per group (1 color, 1 number)
- Task #12: Yellow Starbursts Act 1
- Task #13: Yellow Starbursts Act 2 & 3
- Task #14: Starbursts Simulation
- Task #15: Probability Practice
- Optional: Starburst candies (at least 20 packs of two per class)

Review Copy  
Not for Distribution

## Probability and One-Variable Statistics

# Lesson 5 of 11

## Formative Assessment Lesson: Evaluating Statements about Probability

### Description:

---

This lesson will address students' misconceptions related to the probability of simple and compound events. This lesson will help assess how well students understand concepts of equally likely events, randomness, and sample size.

From the Shell Center Formative Assessment Lesson: Evaluating Statements about Probability

### College- and Career-Readiness Standards Addressed:

---

- SP Find probabilities of compound events using organized lists, tables, tree diagrams, and simulation.

### Process Readiness Indicator(s) Emphasized:

---

- PRI 1: Make sense of problems and persevere in solving through reasoning and exploration
- PRI 3: Describe and justify mathematical understandings by constructing viable arguments, critiquing the reasoning of others and engaging in meaningful mathematical discourse.
- PRI 4: Contextualize mathematical ideas by connecting them to real-world situations. Model with mathematics.
- PRI 6: Attend to precision.
- PRI 7: Look for and make use of patterns and structure.
- PRI 9: Demonstrate flexible use of strategies and methods while reflecting on which procedures
- PRI 10: Reflect on mistakes and misconceptions to improve mathematical understanding.

Students will engage in the Formative Assessment Lesson: Evaluating Statements about Probability, which can be found at: <http://map.mathshell.org/download.php?fileid=1660>

The following *Formative Assessment Lesson* is a classroom-ready lesson included to help teachers assess and improve students' understanding of mathematical concepts and skills and their ability to use the mathematical process readiness indicators critical for college readiness.

Research has shown that formative assessment, as embodied in the following lesson, is a powerful way to improve student learning and performance. This approach first allows students to demonstrate their prior understandings and abilities in employing the mathematical processes, and then resolve their own difficulties and misconceptions through structured discussion. This results in more secure long-term learning, reducing the need for re-teaching that otherwise takes so much classroom time.

Many often ask, why don't students just remember the procedures they have been taught and practiced? The fact is, that approach works fine in the short term but, as every teacher knows, if procedural knowledge is not underpinned by conceptual understanding, students will quickly forget "how to do it."

Read more about the *Formative Assessment Lesson* rationale, structure, and philosophy using the *Brief Guide for Teachers and Administrators* that can be found at <http://map.mathshell.org/materials/index.php>.

Review Copy  
Not for Distribution

---

## CONCEPT DEVELOPMENT

---

Mathematics Assessment Project  
**CLASSROOM CHALLENGES**  
A Formative Assessment Lesson

# Evaluating Statements About Probability

Not for Review Copy  
Not for Distribution

Mathematics Assessment Resource Service  
University of Nottingham & UC Berkeley

For more details, visit: <http://map.mathshell.org>  
© 2015 MARS, Shell Center, University of Nottingham  
May be reproduced, unmodified, for non-commercial purposes under the Creative Commons license  
detailed at <http://creativecommons.org/licenses/by-nc-nd/3.0/> - all other rights reserved

## BEFORE THE LESSON

### Assessment task: *Are They Correct?* (15 minutes)

Ask students to complete this task, in class or for homework, a few days before the formative assessment lesson. This will give you an opportunity to assess the work. You will then be able to find out the kinds of difficulties students have with it. You should then be able to target your help more effectively in the subsequent lesson.

Give out the assessment task *Are They Correct?*

Briefly introduce the task and help the class to understand each problem.

*Read through each statement and make sure you understand it.*

*Try to answer each question as carefully as you can.*

*Show all your work so that I can understand your reasoning.*

It is important that, as far as possible, students are allowed to answer the questions without your assistance.

Students should not worry too much if they cannot understand or do everything, because in the next lesson they will engage in a similar task, which should help them. Explain to students that by the end of the next lesson, they should expect to answer questions such as these confidently. This is their goal.

### Assessing students' responses

Collect students' responses to the task. Make some notes on what their work reveals about their current levels of understanding and their different problem solving approaches.

We suggest that you do not score students' work. The research shows that this will be counterproductive, as it will encourage students to compare their scores and will distract their attention from what they can do to improve their mathematics.

Instead, help students to make further progress by summarizing their difficulties as a series of questions. Some suggestions for these are given in the *Common issues* table on the next page. These have been drawn from common difficulties observed in trials of this unit.

We recommend that you either:

- write one or two questions on each student's work, or
- give each student a printed version of your list of questions and highlight the questions for each individual student.

### Are They Correct?

1. Emma claims:   
 Tomorrow it will either rain or not rain. The probability that it will rain is 0.5.

Is she correct? Explain your answer fully:

.....

.....

.....

2. Susan claims:   
 If a family has already got four boys, then the next baby is more likely to be a girl than a boy.

Is she correct? Explain your answer fully:

.....

.....

.....

3. Tanya claims:   
 If you roll a fair number cube four times, you are more likely to get 2, 3, 1, 6 than 6, 6, 6, 6.

Is she correct? Fully explain your answer:

.....

.....

.....



If you do not have time to do this, you could select a few questions that will be of help to the majority of students and write these questions on the board when you return the work to the students at the start of the follow-up lesson.

Common issues:	Suggested questions and prompts:
<p><b>Q1. Assumes that both outcomes are equally likely</b></p>	<ul style="list-style-type: none"> <li>• What factors affect whether it will rain tomorrow?</li> <li>• What does a probability of 0.5 mean?</li> </ul>
<p><b>Q2. Assumes that likelihood is based on the pattern of recent events</b></p> <p>For example: The student argues that if there are already four boys in the family, the next child is likely to be a girl.</p>	<ul style="list-style-type: none"> <li>• What is the probability that the baby will be a girl?</li> <li>• What is the probability that the baby will be a boy?</li> <li>• Does the fact that there are already four boys in the family affect the gender of the next child?</li> </ul>
<p><b>Q3. Relies on own experiences</b></p> <p>For example: The student states they have never thrown four sixes in a row.</p>	<ul style="list-style-type: none"> <li>• Is it more difficult to throw a six than a two?</li> <li>• Is it more difficult to throw a six, then another six or a two, then a three?</li> </ul>
<p><b>Q3. Assumes that some numbers on a number cube are harder to roll than others</b></p>	<ul style="list-style-type: none"> <li>• What is the probability of rolling a six on a number cube?</li> <li>• What is the probability of rolling a two on a number cube?</li> </ul>

## SUGGESTED LESSON OUTLINE

### Whole-class interactive introduction (15 minutes)

Give each student a mini-whiteboard, a pen, and an eraser.

Display Slide P-1 of the projector resource:

**Two Bags of Jellybeans**

I have two bags **A** and **B**. Both contain red and yellow jellybeans.

There are more red jellybeans in bag **A** than in bag **B**.

If I choose one jellybean from each bag I am more likely to choose a red one from bag **A** than from bag **B**.

Ensure the students understand the problem:

*Your task is to decide if the statement is true.*

*Once you have made a decision you need to convince me.*

Allow students a few minutes to think about the problem individually, then a further few minutes to discuss their initial ideas in pairs. Ask students to write their explanations on their mini-whiteboard.

If students are unsure, encourage them to think of a simple experiment that could simulate the statement:

*Do you know how many red and yellow jellybeans are in each bag?*

*Give me an example of the numbers of jellybeans in each bag.*

*Draw a picture of the situation.*

*Can you think of a situation for which the statement is true? [For example, two red jellybeans and one yellow jellybean in bag A and one red jellybean and one yellow jellybean in bag B.]*

*Can you think of a situation for which the statement is false? [For example, two red jellybeans and three yellow jellybeans in bag A and one red jellybean and one yellow jellybean in bag B.]*

Ask students to show you their mini-whiteboards. Select two or three students with different answers to explain their reasoning on the board. Encourage the rest of the class to comment.

Then ask:

*Chen, can you rewrite the statement so that it is always true?*

*Carlos, do you agree with Chen's explanation? Put Chen's explanation into your own words.*

*Does anyone have a different statement that is also always true?*

This statement highlights the misconception that students often think the results of random selection are dependent on numbers rather than ratios.

**Collaborative activity (20 minutes)**

Organize the class into pairs of students.

Give each pair a copy of *True, False or Unsure?* (cut up into cards), a large piece of paper for making a poster, and a glue stick.

Ask students to divide their paper into two columns: one for statements they think are true, and the other for statements they think are false.

Ask students to take each statement in turn:

*Select a card and decide whether it is a true or false statement.*

*Convince your partner of your decision.*

*It is important that you both understand the reasons for the decision. If you don't agree with your partner, explain why. You are both responsible for each other's learning.*

*If you are both happy with the decision, glue the card onto the paper. Next to the card, write reasons to support your decision.*

*Put to one side any cards you are unsure about.*

You may want to display Slide P-2 of the projector resource, which summarizes these instructions.

You have two tasks during small group work: to make a note of student approaches to the task and to support student problem solving.

**Make a note of student approaches to the task**

Notice how students make a start on the task, whether they get stuck and how they respond if they do come to a halt. For example, are students drawing diagrams, working out probabilities, or simply writing a description? As they work on the task, listen to their reasoning carefully and note misconceptions that arise for later discussion with the whole-class.

**Support student problem solving**

Try not to make suggestions that move students towards a particular approach to this task. Instead, ask questions to help students clarify their thinking. If several students in the class are struggling with the same issue, write a relevant question on the board and hold a brief whole-class discussion.

Here are some questions you may want to ask your students:

Card A: This statement addresses the misconception that probabilities give the proportion of outcomes that *will* occur.

*Is it possible to get five sixes in a row with a fair six-sided number cube?*

*Is it more difficult to roll a six than, say, a two?*

Card B: This statement addresses the misconception that 'special' events are less likely than 'more representative' events. Students often assume that selecting an 'unusual' letter, such as W, X, Y or Z is a less likely outcome.

*Is the letter X more difficult to select than the letter T?*

*Are the letters W and X more difficult to select than the letters D and T?*

Card C: This statement addresses the misconception that later random events 'compensate' for earlier ones.

*Does the coin have a memory?*

Card D: This statement addresses the misconception that all outcomes are equally likely, without considering that some are much more likely than others.

*Is the probability of a local school soccer team beating the World Cup champions  $\frac{1}{3}$ ?*

Card E: This statement addresses the misconception that all outcomes are equally likely, without considering that some are much more likely than others. Students often simply count the different outcomes.

*Are all three outcomes equally likely? How do you know? How can you check your answer?*

*What are all the possible outcomes when two coins are tossed? How does this help?*

Card F: This statement addresses the misconception that the two outcomes are equally likely.

*How can you check your answer?*

*In how many ways can you score a three?*

*In how many ways can you score a two?*

Card G: This statement addresses the misconception that probabilities give the proportion of outcomes that *will* occur.

*When something is certain, what is its probability?*

*What experiment could you do to check if this answer is correct? [One student writes the ten answers e.g. false, true, true, false, true, false, false, false, true, false. Without seeing these answers the other student guesses the answers.]*

Card H: This statement addresses the misconception that the sample size is irrelevant. Students often assume that because the probability of one head in two coin tosses is  $\frac{1}{2}$ , the probability of  $n$  heads in  $2n$  coin tosses is also  $\frac{1}{2}$ .

*Is the probability of getting one head in two coin tosses  $\frac{1}{2}$ ? How do you know?*

*Show me a possible outcome if there are four coin tosses. Show me another.*

*How many possible outcomes are there?*

*How many outcomes are there with two heads?*

### Sharing work (10 minutes)

As students finish the task, ask them to compare work with a neighboring pair.

*Check which answers are different.*

*A member of each group needs to explain their reasoning for these answers. If anything is unclear, ask for clarification.*

*Then, together, consider if you should change any of your answers.*

*It is important that everyone in both groups understands the math. You are responsible for each other's learning.*

### Whole-class discussion (15 minutes)

Organize a discussion about what has been learned. Focus on getting students to understand the reasoning, not just checking that everyone produced the same answers.

Ask students to choose one card they are certain is true and to explain why they are certain to the rest of the class. Repeat this with the statements that students believe are false. Finally, as a whole-class, tackle the statements that students are not so sure about.

*Ben, why did you decide this statement was true/false?*

*Does anyone agree/disagree with Ben?*

*Does anyone have a different explanation to Ben's?*

In addition to asking for a variety of methods, pursue the theme of listening and comprehending each other's methods by asking students to rephrase each other's reasoning.

*Danielle, can you put that into your own words?*

You may also want to ask students:

*Select two cards that use similar math. Why are they similar? Is there anything different about them? [Students are likely to select cards D and E.]*

In trials, students have found card H challenging.

*What are the possible outcomes? Have you listed all of the outcomes? Have you listed all the outcomes where there are two heads? What does this show?*

**Follow-up lesson: reviewing the assessment task (20 minutes)**

Give each student a copy of the review task *Are They Correct? (Revisited)* and their original scripts from the assessment task, *Are They Correct?* If you have not added questions to individual pieces of work, write your list of questions on the board. Students should select from this list only those questions they think are appropriate to their own work.

*Read through your scripts from Are They Correct? and the questions [on the board/written on your script]. Answer these questions and revise your response.*

*Now look at the new task sheet, Are They Correct (Revisited). Can you use what you've learned to answer these questions?*

If students struggled with the original assessment task, you may feel it more appropriate for them to try *Are They Correct?* again, rather than or before attempting *Are They Correct? (Revisited)*. If this is the case give them another copy of the original assessment task instead/as well.

Some teachers give this as a homework task.

## SOLUTIONS

### Assessment Task: Are They Correct?

1. This statement is incorrect. It highlights the misconception that all events are equally likely. There are many factors (e.g. the season) that will influence the chances of it raining tomorrow.
2. Assuming that the sex of a baby is a random, independent event equivalent to tossing a coin, the statement is incorrect. It highlights the misconception that later random events can ‘compensate’ for earlier ones. The assumption is important: there are many beliefs and anecdotes about what determines the gender of a baby, but ‘tossing a coin’ turns out to be a reasonably good model<sup>1</sup>.
3. This statement is incorrect. This highlights the misconception that ‘special’ events are less likely than ‘more representative’ events.

### Assessment Task: Are They Correct? (revisited)

1. This statement is incorrect. It is not known whether the four sections on the spinner are in equal proportion. The probability of getting the red section would only be 0.25 if this were the case.
2. This statement is true. There are more students than days of the week.
3. This statement is incorrect. There are many factors that could affect whether or not the school bus is on time. There is also a chance that the bus is early.

### Collaborative Activity: True, False or Unsure?

- A. If you roll a six-sided number cube and it lands on a six more than any other number, then the number cube must be biased.  
  
False. This statement addresses the misconception that probabilities give the proportion of outcomes that **will** occur. With more information (**How many** times was the cube rolled? **How many** more sixes were thrown?) more advanced mathematics could be used to calculate the **probability** that the number cube was biased, but you could never be 100% certain.
- B. When randomly selecting four letters from the alphabet, you are more likely to come up with D, T, M, J than W, X, Y, Z.  
  
False. This highlights the misconception that ‘special’ events are less likely than ‘more representative’ events. Students often assume that selecting the ‘unusual’ letters W, X, Y and X is less likely.
- C. If you toss a fair coin five times and get five heads in a row, the next time you toss the coin it is more likely to show a tail than a head.  
  
False. This highlights the misconception that later random events ‘compensate’ for earlier ones. The statement implies that the coin has some sort of ‘memory’. People often use the phrase ‘the law of averages’ in this way.
- D. There are three outcomes in a soccer match: win, lose, or draw. The probability of winning is therefore  $\frac{1}{3}$ .  
  
False. This highlights the misconception that all outcomes are equally likely, without considering that some are much more likely than others. The probabilities are dependent on the rules of the game and which teams are playing.

<sup>1</sup> See, for example, <http://www.bbc.co.uk/news/magazine-12140065>

- E. When two coins are tossed there are three possible outcomes: two heads, one head, or no heads. The probability of two heads is therefore  $\frac{1}{3}$ .

False. This highlights the misconception that all outcomes are equally likely, without considering that some are much more likely than others. There are four equally likely outcomes: HH, HT, TH, TT. The probability of two heads is  $\frac{1}{4}$ .

- F. Scoring a total of three with two number cubes is twice as likely as scoring a total of two.

True. This highlights the misconception that the two outcomes are equally likely. To score three there are two outcomes: 1, 2 and 2, 1, but to score two there is only one outcome, 1, 1.

- G. In a ‘true or false?’ quiz with ten questions, you are certain to get five correct if you just guess.

False. This highlights the misconception that probabilities give the exact proportion of outcomes that will occur. If a lot of people took the quiz, you would expect the mean score to be *about* 5, but the individual scores would vary.

Probabilities do not say for certain what will happen, they only give an indication of the likelihood of something happening. The only time we can be certain of something is when the probability is 0 or 1.

- H. The probability of getting exactly two heads in four coin tosses is  $\frac{1}{2}$ .

False. This highlights the misconception that the sample size is irrelevant. Students often assume that because the probability of one head in two coin tosses is  $\frac{1}{2}$ , then the probability of  $n$  heads in  $2n$  coin tosses is also  $\frac{1}{2}$ . In fact the probability of two out of four coin tosses being heads is  $\frac{6}{16}$ .

This can be worked out by writing out all the sixteen possible outcomes:

HHHH, HHHT, HHHT, HTHH, THHH, TTTT, TTTH, TTHT, THTT, HTTT, HHTT, HTTH, TTHH, THTH, HTHT, THHT.

This may be calculated from Pascal’s triangle:

	1								
2 coins		1	2	1					4 outcomes
		1	3	3	1				
4 coins		1	4	6	4	1			16 outcomes
		1	5	10	10	5	1		
6 coins	1	6	15	20	15	6	1		64 outcomes
									Probability(3 heads)

**Students are not expected to make this connection!**

## Are They Correct?

1. Emma claims:

Tomorrow it will either rain or not rain. The probability that it will rain is 0.5.



Is she correct? Explain your answer fully:

---

---

---

---

2. Susan claims:

If a family has already got four boys, then the next baby is more likely to be a girl than a boy.



Is she correct? Explain your answer fully:

---

---

---

---

3. Tanya claims:

If you roll a fair number cube four times, you are more likely to get 2, 3, 1, 6 than 6, 6, 6, 6.



Is she correct? Fully explain your answer:

---





---

---

---



## Card Set: True, False Or Unsure?

<p>A. If you roll a six-sided number cube and it lands on a six more than any other number, then the number cube must be biased.</p> 	<p>B. When randomly selecting four letters from the alphabet, you are more likely to come up with D, T, M, J than W, X, Y, Z.</p>
<p>C. If you toss a fair coin five times and get five heads in a row, the next time you toss the coin it is more likely to show a tail than a head.</p>	<p>D. There are three outcomes in a soccer match: win, lose, or draw. The probability of winning is therefore <math>\frac{1}{3}</math>.</p> 
<p>E. When two coins are tossed there are three possible outcomes: two heads, one head, or no heads. The probability of two heads is therefore <math>\frac{1}{3}</math>.</p>	<p>F. Scoring a total of three with two number cubes is twice as likely as scoring a total of two.</p> 
<p>G. In a 'true or false?' quiz with ten questions, you are certain to get five correct if you just guess.</p> 	<p>H. The probability of getting exactly two heads in four coin tosses is <math>\frac{1}{2}</math>.</p> 

## Are They Correct? (revisited)

1. Andrew claims:

A spinner has 4 sections - red, yellow, green, and blue. The probability of getting the red section is 0.25.

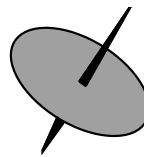

Is he correct? Explain your answer fully:

---

---

---

---

2. Stephen claims:

In a group of ten students the probability of two students being born on the same day of the week is 1.



Is he correct? Explain your answer fully:

---

---

---

---

3. Thomas claims:

The school bus will either be on time or late. The probability that it will be on time is therefore 0.5.



Is he correct? Fully explain your answer:

---

---

---

---

## Two Bags of Jellybeans

I have two bags **A** and **B**. Both contain red and yellow jellybeans.

There are more red jellybeans in bag **A** than in bag **B**.

If I choose one jellybean from each bag I am more likely to choose a red one from bag **A** than from bag **B**.

## True, False or Unsure?

- Take turns to select a card and decide whether it is a true or false statement.
- Convince your partner of your decision.
- It is important that you both understand the reasons for the decision. If you don't agree with your partner, explain why. You are both responsible for each other's learning.
- If you are both happy with the decision, glue the card onto the paper. Next to the card, write reasons to support your decision.
- Put to one side any cards you are unsure about.

## Mathematics Assessment Project **Classroom Challenges**

These materials were designed and developed by the  
Shell Center Team at the Center for Research in Mathematical Education  
University of Nottingham, England:

**Malcolm Swan,**  
**Nichola Clarke, Clare Dawson, Sheila Evans, Colin Foster, and Marie Joubert**  
with  
**Hugh Burkhardt, Rita Crust, Andy Noyes, and Daniel Pead**

We are grateful to the many teachers and students, in the UK and the US,  
who took part in the classroom trials that played a critical role in developing these materials

The classroom observation teams in the US were led by  
**David Foster, Mary Bouck, and Diane Schaefer**

This project was conceived and directed for  
The Mathematics Assessment Resource Service (MARS) by  
**Alan Schoenfeld** at the University of California, Berkeley, and  
**Hugh Burkhardt, Daniel Pead, and Malcolm Swan** at the University of Nottingham

Thanks also to Mat Crosier, Anne Floyde, Michael Galan, Judith Mills, Nick Orchard, and Alvaro Villanueva who contributed to the design and production of these materials

This development would not have been possible without the support of  
**Bill & Melinda Gates Foundation**

We are particularly grateful to  
**Carina Wong, Melissa Chabran, and Jamie McKee**

The full collection of Mathematics Assessment Project materials is available from

<http://map.mathshell.org>

© 2015 MARS, Shell Center, University of Nottingham  
This material may be reproduced and distributed, without modification, for non-commercial purposes,  
under the Creative Commons License detailed at <http://creativecommons.org/licenses/by-nc-nd/3.0/>  
All other rights reserved.

Please contact [map.info@mathshell.org](mailto:map.info@mathshell.org) if this license does not meet your needs.

## Probability and One-Variable Statistics

# Lesson 6 of 11

## Statistical Questions

### Description:

---

Students learn how to recognize a statistical question and must be able to justify their reasoning for why a question is or is not a statistical question. For questions that do not anticipate variability in the answers, students will rewrite the questions to make each one a statistical question.

### College- and Career-Readiness Standard(s) Addressed:

---

- SP.1 Recognize a statistical question as one that anticipates variability in the data related to the question and accounts for it in the answers. For example, “How old am I?” is not a statistical question, but “How old are the students in my school?” is a statistical question because one anticipates variability in students’ ages.
- SP.2 Understand that a set of data collected to answer a statistical question has a distribution which can be described by its center, spread, and overall shape.

### Process Readiness Indicator(s) Emphasized:

---

- PRI 1: Make sense of problems and persevere in solving through reasoning and exploration.
- PRI 3: Describe and justify mathematical understandings by constructing viable arguments, critiquing the reasoning of others and engaging in meaningful mathematical discourse.

## Engage

### PRI 1

*Teacher's Note:* The following lesson is from <https://www.engageny.org/resource/grade-6-mathematics-module-6>

Present students with Task #16: What is a Statistical Question? which can be found in the Student Manual.

#### INCLUDED IN THE STUDENT MANUAL

### Task #16: What is a Statistical Question?

Jerome, a 9th grader at Central High School, is a huge baseball fan. He loves to collect baseball cards. He has cards of current players and players from past baseball seasons. With his teacher's permission, Jerome brought a sample of his baseball card collection to school. Each card has a picture of a current or past Major League Baseball player, along with information about the player. When he placed his cards out for the other students to see, they asked Jerome all sorts of questions about his cards. Some asked:

- How many cards does Jerome have altogether?
- What is the typical cost of a card in Jerome's collection?
- Where did Jerome get the cards?

**A statistical question is one that can be answered by collecting data and where there will be variability in that data.**

1. Which of the questions above do you think might be a statistical question?

Ask students to explore and make sense of this question with a Think-Pair-Share activity.

- Which of these questions do you think might be statistical questions?

While students are sharing, it may be necessary to review what "variability" means. Students should conclude that the second and third questions are statistical questions because the answers to those questions could vary. The first question, however, has a single numerical answer and therefore will have no variability in the data.

Present students with the plot on the next page displaying the value of the baseball cards Jerome brought to school. Ask students to discuss the plot with a partner and to list any observations of the data.

Facilitate a whole-group discussion. Make notes on the board or chart paper. Be sure to note any statistics vocabulary that is mentioned.

INCLUDED IN THE STUDENT MANUAL

### Task #16: What is a Statistical Question? contd.

The dot plot below shows the value of the baseball cards Jerome brought to school.

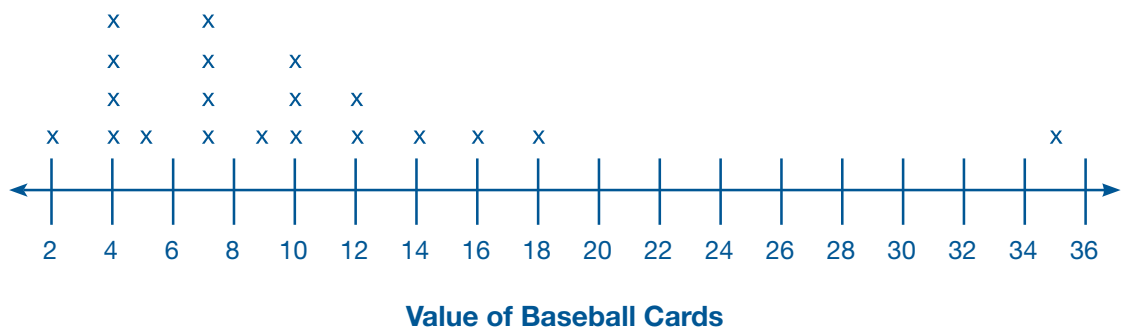

2. What observations can you make about the data?

---

---

---

*Teacher's Note: The reason for having students engage in this discussion is to bring out any relevant vocabulary that students may remember from studying statistics in the middle grades. A sample student response may be: The data is skewed right and clustered around \$7. The data point \$35 is an outlier since it lies far away from the other data. The outlier would most likely cause the mean to be greater than the median.*

Vocabulary that may be discussed includes:

- Dot plot (line plot)
- Measures of center (mean, median, mode)
- Measures of variability (mean absolute deviation, interquartile range)
- Five-number summary
- Box plot
- One-variable data
- Outlier
- Skewness
- Shape
- Spread
- Distribution
- Range

Share with students that in the remaining lessons in this unit, they will be analyzing and interpreting statistical data.



## Explore

**PRI 1**  
**PRI 3**

*Teacher's Note:* This activity can be found at <https://www.illustrativemathematics.org/content-standards/6/SP/A/1/tasks/2008>.

Direct students to work with a partner to persevere in solving Task #17: Statistical Questions Part 1 in the Student Manual.

INCLUDED IN THE STUDENT MANUAL

### Task #17: Statistical Questions Part 1

Last night, Jennifer and her family went out for dinner. The questions below came up on their way to the restaurant or during the meal. Decide whether or not each question is a statistical question, and justify your decision.

a. How far are we from the restaurant?

---

---

b. How long will it be until we get there?

---

---

c. Would Jennifer rather have burgers or pizza?

---

---

d. What is the most frequently ordered dish on Saturday nights?

---

---

e. Do customers at the restaurant like pizza?

---

---

f. What is a typical bill for tables at this restaurant?

---

---

g. On average, how many people were sitting at each table this evening?

---

---

### Task #17: Statistical Questions Part 1 KEY

- This is not a statistical question if the route to the restaurant is determined or if the question is intended “as the crow flies”. In these cases, it would be a fixed numerical answer, which is likely what is intended by the question. It could be viewed as a statistical question if it referred to time rather than distance (e.g. On average, how long does it take to get home from the restaurant?).
- Unlike the first question, this is a statistical question. Variables such as traffic signals and the amount of traffic rule out an exact answer. The answer will be an approximation based on repeated experience of similar conditions and drives. That is, the answer would be based on data that vary.

- c. This question refers to a single person and so it would be answered based on a single response and not on data that vary.
- d. This question is statistical since it involves Saturday nights, in general, not one particular Saturday night. Therefore, there will likely be variability in the data.
- e. This is a statistical question (unless we know in advance that everyone is going to say yes or no).
- f. This is a statistical question. It would be answered by collecting data on the amount of the bill for different tables, and this amount would vary from table to table.
- g. Like the previous question, this is a statistical question. It would be answered by collecting data on the number of people at a table from many tables and there would be variability in the data collected.

Share with students that the focus of your work as you walk around and listen to each pair will be to listen specifically for their justifications of mathematical understanding. In their own words, students should explain that the answers to each question may or may not vary.

Before moving on to the next section, discuss any questions in the task in which students had difficulty.

## Explanation

**PRI 1**  
**PRI 3**

*Teacher's Note: The cards for the "Statistical Questions Part 2" task should be cut prior to implementing this lesson with students. In this activity, more than one group should have the same set of four questions. A blackline master for these cards can be found at the end of this lesson. This provides the opportunity for each group to present to the class at least once, yet still have a manageable number of questions in which to discuss. The questions for this task were adapted from <https://www.illustrativemathematics.org/content-standards/6/SP/A/1/tasks/703> and <https://www.engageny.org/resource/grade-6-mathematics-module-6>.*

Give each group of 2-3 students a set of four cards for the "Statistical Questions Part 2" task. Explain that students must reason with the members of their group to determine if each question is a statistical question and be prepared to justify their solutions. Each group will share their work on chart paper to present to the class where they will justify their mathematical reasoning and critique the reasoning of others. Whether or not each question below is a statistical question is indicated in parentheses after the question.

- How many days are in March? (No)
- How many years, on average, have the teachers in my school been teaching? (Yes)
- How old is your dog? (No)
- What are the favorite colors of 9th graders in my school? (Yes)
- What was the highest temperature today in your city/town? (No)
- On average, how old are the dogs that live on this street? (Yes)
- Who is my favorite movie star? (No)
- What proportion of the students at your school like watermelons? (Yes)

- Do you like watermelons? (No)
- How many years have students in my school's band or orchestra played an instrument? (Yes)
- How old is the principal at our school? (No)
- What is the favorite subject of students in my school? (Yes)

After all chart paper is displayed, ask each group to present their thinking about one question to the class. After each question is presented, the class should have the opportunity to disagree or to rephrase the reasoning given. Because all solutions will be displayed, any inconsistencies across groups can be discussed as well.

### Enrichment

For students who need an enrichment activity, ask them to create a list of possible ways to collect data in order to answer the questions they determined were statistical in nature. Ask these students to present their data collection ideas during the whole-group discussion.

### Practice in small groups

*Teacher's Note: The questions below can be found at <https://www.engageny.org/resource/grade-6-mathematics-module-6>.*

Ask students to work again with a partner on the Task #18: Creating Statistical Questions in the Student Manual. Explain that students will rewrite the four questions as statistical questions. You may want to ask students to work on each of the four questions individually first, and then share with their partner. The pairs can then compare each question.

#### INCLUDED IN THE STUDENT MANUAL

### Task #18: Creating Statistical Questions

Rewrite each of the following questions as a statistical question.

1. How many pets does your teacher have?

2. How many points did the high school soccer team score in its last game?

3. Can I do a handstand?

4. How old is the principal at my school?

**Task #18: Creating Statistical Questions KEY**

1. How many pets does your teacher have?  
*How many pets, on average, do the teachers in your school have?*
2. How many points did the high school soccer team score in its last game?  
*How many points does the high school soccer team score in a typical game?*
3. Can I do a handstand?  
*Can students in my school do a handstand?*
4. How old is the principal at my school?  
*How old, on average, are high school principals?*

**Evaluate Understanding**

Facilitate a whole-group discussion about Task #18: Creating Statistical Questions. Instruct students to complete Task #19: Lesson 6 - Exit Ticket in the Student Manual individually.

INCLUDED IN THE STUDENT MANUAL

**Task #19: Lesson 6 - Exit Ticket**

Determine if each question is a statistical question. For each question, explain your mathematical thinking. If it is not a statistical question, rewrite the question so that it is.

1. How many hours each day does a typical student in my class play video games?

---

---

---

2. How many miles does my teacher drive to school each day?

---

---

---

**Task #19: Lesson 6 - Exit Ticket KEY**

Determine if each question is a statistical question. For each question, explain your mathematical thinking. If it is not a statistical question, rewrite the question so that it is.

1. How many hours each day does a typical student in my class play video games?  
*This is a statistical question because the number of hours spent playing video games will vary for students.*
2. How many miles does my teacher drive to school each day?  
*This is not a statistical question because my teacher likely takes the same route everyday and therefore, there will not be variability in the number of miles driven. A question with variability might be "How many miles do the teachers at my school drive to work each day?"*

## Closing Activity

### PRI 1

Present students with the two-way table from Lesson 1. Allow them time to study and make sense of the table.

	Recommended for Promotion	Not Recommended for Promotion	Total
Male	21	3	24
Female	14	10	24
Total	35	13	48

Ask them to share what they remember about the situation. After students are able to recall the situation, ask:

- What might be an appropriate statistical question for the situation?

Allow students time to brainstorm possible questions and share. One such statistical question would be “Is there an association between gender of an applicant and the promotion status of the applicant by bank supervisors?” However, students are likely to arrive at a less sophisticated question such as “Is there gender discrimination of female applicants by bank supervisors?”

Use the gender discrimination situation as a basis for your discussion to review what was learned about statistical questions from today’s lesson. Make sure to address any misconceptions uncovered during the lesson.

## Independent Practice:

- Task #20: Buttons: Statistical Questions <https://www.illustrativemathematics.org/content-standards/tasks/1040>

INCLUDED IN THE STUDENT MANUAL

### Task #20: Buttons: Statistical Questions

Zeke likes to collect buttons and he keeps them in a jar. Zeke can empty the buttons out of the jar, so he can see all of his buttons at once.

1. Which of the following are statistical questions that someone could ask Zeke about his buttons? For each question, explain why it is or is not a statistical question.
  - a. What is a typical number of holes for the buttons in the jar?  
 \_\_\_\_\_
  - b. How many buttons are in the jar?  
 \_\_\_\_\_
  - c. How large is the largest button in the jar?  
 \_\_\_\_\_

d. If Zeke grabbed a handful of buttons, what are the chances that all of the buttons in his hand are round?

e. What is a typical size for the buttons in the jar?

f. How are these buttons distributed according to color?

2. Write another statistical question related to Zeke's button collection.

**Task #20: Buttons: Statistical Questions KEY**

1.
  - a. Statistical question
  - b. Not a statistical question
  - c. Not a statistical question
  - d. Statistical question
  - e. Statistical question
  - f. Statistical question
2. Some possible statistical questions are:
  - What is a typical shape for buttons in the jar?
  - What is the distribution of the diameters of the round buttons in this jar?

**Resources/Instructional Materials Needed:**

- Task #16: What is a Statistical Question?
- Task #17: Statistical Questions Part 1
- Card for "Statistical Questions Part 2"
- Task #18: Creating Statistical Questions
- Task #19: Lesson 6 - Exit Ticket
- Task #20: Buttons: Statistical Questions

**Blackline Master - Cards for Statistical Questions Part 2**

How many days are in March?	How many years, on average, have the teachers in my school been teaching?
How old is your dog?	What are the favorite colors of 9th graders in my school?
What was the highest temperature today in your city/town?	On average, how old are the dogs that live on this street?
Who is my favorite movie star?	What proportion of the students at your school like watermelons?
Do you like watermelons?	How many years have students in my school's band or orchestra played an instrument?
How old is the principal at our school?	What is the favorite subject of students in my school?

Not for Review Copy  
Distribution

## Probability and One-Variable Statistics

# Lesson 7 of 11

## Summarizing and Describing Distributions

### Description:

---

In this lesson, students will analyze a set of univariate data given a dot plot and box plot. Students will select and calculate appropriate measures of center and variability and will communicate about the distributions orally and in writing.

### College- and Career-Readiness Standard(s) Addressed:

---

- SP.3 Recognize that a measure of center for a numerical data set summarizes all of its values with a single number, while a measure of variation describes how its values vary with a single number.
- SP.4 Display numerical data in plots on a number line, including dot plots, histograms, and box plots.
- SP.5 Summarize numerical data sets in relation to their context, such as by:
  - Reporting the number of observations
  - Describing the nature of the attribute under investigation, including how it was measured and its units of measurement
  - Giving quantitative measures of center (median and/or mean) and variability (interquartile range and/or mean absolute deviation), as well as describing any overall pattern and any striking deviations from the overall pattern with reference to the context in which the data were gathered.
  - Relating the choice of measures of center and variability to the shape of the data distribution and the context in which the data were gathered.

### Process Readiness Indicator(s) Emphasized:

---

- PRI 1: Make sense of problems and persevere in solving through reasoning and exploration
- PRI 3: Describe and justify mathematical understandings by constructing viable arguments, critiquing the reasoning of others and engaging in meaningful mathematical discourse.
- PRI 6: Attend to precision.



Sequence of  
Instruction

Activities Checklist

## Engage

Begin class by reading the story Chrysanthemum by Kevin Henkes. A video of this story being read aloud can also be found at:

<https://www.youtube.com/watch?v=kxMlxbgYvLI>

Ask the students to estimate the “average” length of first names of the students in the class. Record these estimates to revisit in the closing. Engage in a discussion on the various measures of average that they have studied in the past and define prior vocabulary (mean, median, mode, range, and quartile) as needed.

## Explore

PRI 1  
PRI 6

Teacher’s Note: This activity has been adapted from  
<http://www.learnnc.org/lm/pages/3767?ref=search>

In this activity, the students will explore and make sense of box plots by creating a human box plot. Give each student an index card to record the length of his/her first name based on the number of letters in his/her first name. Divide the students into two groups – boys and girls. Ask the girls to find Task #21: Human Box Plot in the Student Manual. The girls should record the information in the Student Manual for the boys’ statistics.

With the girls observing, have the boys line up shoulder to shoulder in order from shortest name to longest name. Ask the girls to attend to precision as they find the median and the quartiles. Give the appropriate students the cards that state median, Q1, and Q3 to hold.

Have students with the same name length line up behind each other. All students except one student with each name length along with the quartiles and the median can return to their seats. Place construction paper on the floor to hold a space for any missing name lengths. Unroll the bulletin board paper, and cut a piece long enough to stretch from Q1 to Q3 and have those two students hold the paper in front of them. Use party streamers to make whiskers to stretch from the shortest name to the first quartile and from the third quartile to the longest name. Use tape to attach the whiskers to the box and label the minimum, maximum, quartiles, and median with markers, sticky notes, or index cards. Hang the human box plot on the wall. *Teacher’s Note: Save the box plot to refer to again in Lesson 8 of this unit.*

When the boys’ box plot is complete, have them switch places with the girls. Repeat the process with the girls as the human box plot. The boys should record the girls’ statistics on Task #21: Human Box Plot, part 1 in the Student Manual.

*Teacher’s Note: Pay close attention that students are attending to precision as they create number lines in the Student Manual. Often students will fail to create even intervals and will use only the five numbers in a five number summary to make their dot plots.*

## Explanation

**PRI 1**  
**PRI 3**

Group students in pairs – one girl with one boy. Allow students time to share and compare their work for Task #21: Human Box Plot, part 1 in the Student Manual. A document camera and projector could be used to display student work for a basis of discussion.

Explain to the students how box plots are useful for comparing the range, interquartile range, and median of a set of data.

INCLUDED IN THE STUDENT MANUAL

### Task #21: Human Box Plot

#### Part 1: Dot and Box Plot Construction

- Record the name lengths for all the students in the class here.

Boys	Girls

On the number line below, create a dot plot for the class name-length data. Use an appropriate scale to label your number line so that you will be able to fit your minimum and maximum heights on the graph. Then record each name length on your plot with some mark above the value such as a dot or an x.

**Boys' Name Length**



**Girls' Name Length**



- Find the statistics for the class data.

#### **Boys' Name Length:**

minimum:	maximum:
mean:	median:
mode:	range:
Q <sub>1</sub> :	Q <sub>3</sub> :

**Girls' Name Length:**

minimum:	maximum:
mean:	median:
mode:	range:
$Q_1$ :	$Q_3$ :

4. Use the information from #3 to create a box plot for the class data.

**Boys' Name Length**



**Whole Group Discussion:** Engage the class in a discussion comparing the boys' and girls' name-length box plots. Be sure to encourage students to continue using mathematical language to make their justifications and as they critique the reasoning of others.

Possible discussion questions:

- How are the plots similar? How are they different?
- Which set of data has the largest maximum? Which set has the smallest minimum? How does the range for each set of data compare?
- How does the interquartile range for each set of data compare?
- How might a name that is much longer or shorter affect the data and the plot?

In this activity, students will persevere to understand how to calculate mean absolute deviation as a way to examine data. Instruct students to find Task #21: Human Box Plots, Part 2. in the Student Manual. Explain that students will calculate the mean absolute deviation (MAD), or the mean of the distances of each value from the mean, for the boys' names and the girls' names separately. Explain the MAD is one measure of variability of a data set. Other measures of variability include the range and interquartile range. This activity will be separated into boys' name data and girls' name data again.

Explain to the students how they will complete the chart in the Student Manual by finding the distance of each value from its mean. Instruct the students that distance is always a positive number. Elaborate here on absolute value if appropriate for the class. You may also want to illustrate differences with a simple number line such as the one on the next page.

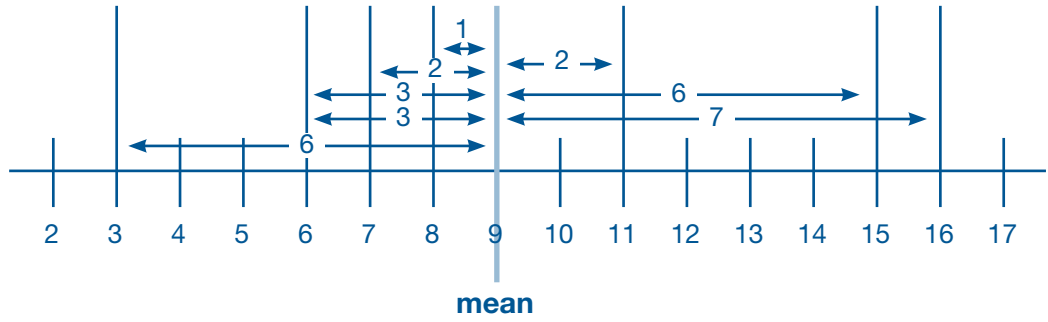

INCLUDED IN THE STUDENT MANUAL

**Task #21: Human Box Plot**

**Part 2: Mean Absolute Deviation**

- In the table below, record the boys' and girls' name lengths and each mean you calculated earlier. Then subtract to find the distance of each name length from its mean.

boys' name-length mean =		girls' name-length mean =	
boys' name lengths	distance from the mean	girls' name lengths	distance from the mean

- Now, find the mean of the distances from the mean for the boys' and girls' name lengths.

boys' name length mean absolute deviation	girls' name length mean absolute deviation
--	---

Explain that students will add all the distances and divide by the total number of values to find the mean absolute deviation.

Refer back to each set of data, and compare means and mean absolute deviation for boys' name length and girls' name length.

### Practice Together in Small Groups

**PRI 1**  
**PRI 3**

Group students into pairs to make sense of and persevere in solving a box plot card sort activity. Explain that students will complete the “Distributions Card Sort” task with their partner. The task involves matching three sets of cards – box plot, data, and description. A blackline master of the Distributions Card Sort can be found at the end of this lesson. Each pair should take turns matching cards and providing a mathematical justification for the match to their partner. Students should glue their cards to chart paper and write their justifications for the matches next to the cards.

### Evaluate Understanding

After the groups have had time to work through this task, lead a class discussion and check the matches together.

Solutions:

- A – 4 – G      • B – 3 – J      • C – 1 – I      • D – 5 – F      • E – 2 – H

### Closing Activity

Refer the students back to the initial question, and revisit the data collected in class. Pose the question again:

- What is the “average” first name length of the class?

Discuss which measure of center seems most appropriate and why. Discuss how close students' guesses were to the actual answer.

### Independent Practice:

- Task #22: Compare and Analyze Data in the Student Manual

**INCLUDED IN THE STUDENT MANUAL**

#### Task #22: Compare and Analyze Data

Use the information in the plots to answer the questions. For each question, justify your reasoning.

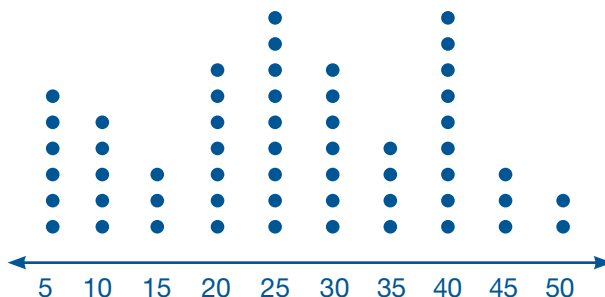

1. What is the mode of the data?
2. What is the median of the data?
3. What is the mean of the data?
4. What is the range of the data?
5. Which measure of center best describes this set of data?

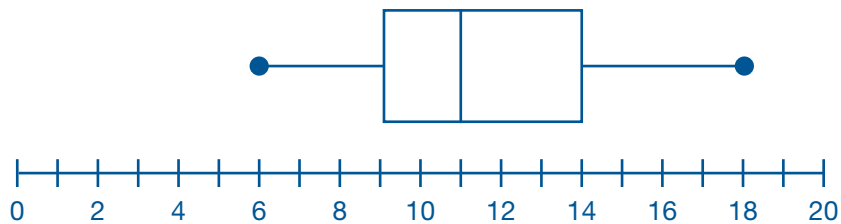

6. What is the minimum value?
7. What is the maximum value?
8. What is the median?
9. What is the range?
10. What is the interquartile range?

### Answers

1. This data is bimodal: 25 and 40.
2. The median is 25.
3. The mean is 26.09
4. The range is 45.
5. Answers may vary. Possible answer: The best measure for this data would be 25, the median and one of the two modes. It is also very close to the mean, 26.
6. The minimum value is 6.
7. The maximum value is 18.
8. The median is 11.
9. The range is 12.
10. The interquartile range is 5.

### Resources/Materials needed:

---

- Chrysanthemum by Kevin Henkes
- Index cards
- Measuring tapes
- 3 cards labeled median, Q1, and Q3
- construction paper
- roll of bulletin board paper
- party streamer or cash register tape
- Distributions Card Sort printed on card stock, one set for each group, pre-cut
- Chart paper
- Task #21: Human Box Plot
- Task #22: Compare and Analyze Data
- Video of Chrysanthemum: <https://www.youtube.com/watch?v=kxMlxbgYvLI>

Not for Review Copy  
Distribution

Distributions Card Sort

Test Scores Set A

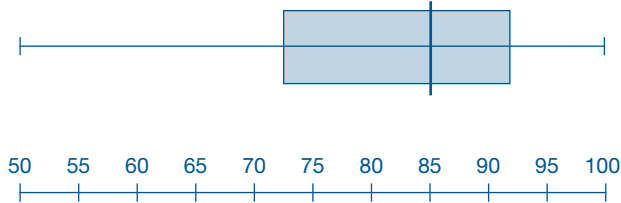

Data Set 1

Min = 40  
Q1 = 44  
Med = 55  
Q3 = 64  
Max = 75

Description F

50% of the students scored between 55 and 79 points.

Test Scores Set B

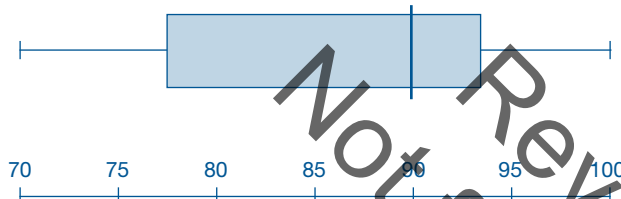

Data Set 2

Min = 60  
Q1 = 67  
Med = 75  
Q3 = 83  
Max = 95

Description G

One-fourth of the students scored higher than 92 points.

Test Scores Set C

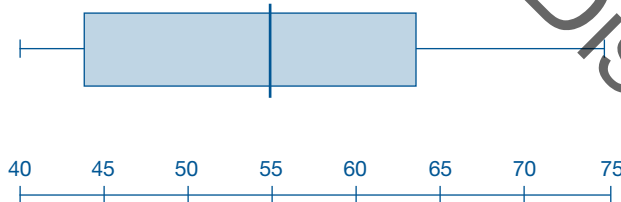

Data Set 3

Min = 70  
Q1 = 77  
Med = 90  
Q3 = 94  
Max = 100

Description H

One-fourth of the students scored between 67 and 75 points.

Test Scores Set D

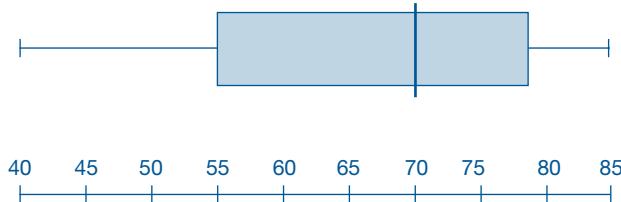

Data Set 4

Min = 50  
Q1 = 72  
Med = 85  
Q3 = 92  
Max = 100

Description I

Half of the students scored 55 points or lower.

Test Scores Set E

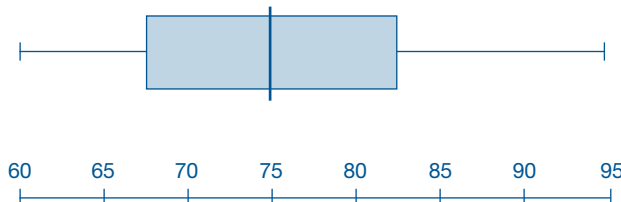

Data Set 5

Min = 40  
Q1 = 55  
Med = 70  
Q3 = 79  
Max = 85

Description J

50% of the students scored 90 points or higher.



## Probability and One-Variable Statistics

# Lesson 8 of 11

## The Effects of Outliers on a Summary Statistics

### Description:

---

Students will build on the previous lesson by creating a human box plot based on classroom data. Students will analyze the distribution and study the effects of outliers on measures of center and variability.

### College- and Career-Readiness Standard(s) Addressed:

---

- SP.3 Recognize that a measure of center for a numerical data set summarizes all of its values with a single number, while a measure of variation describes how its values vary with a single number.
- SP.4. Display numerical data in plots on a number line, including dot plots, histograms, and box plots.
- SP.5. Summarize numerical data sets in relation to their context, such as by:
  - Reporting the number of observations
  - Describing the nature of the attribute under investigation, including how it was measured and its units of measurement
  - Giving quantitative measures of center (median and/or mean) and variability (interquartile range and/or mean absolute deviation), as well as describing any overall pattern and any striking deviations from the overall pattern with reference to the context in which the data were gathered.
  - Relating the choice of measures of center and variability to the shape of the data distribution and the context in which the data were gathered.

### Process Readiness Indicator(s) Emphasized:

---

- PRI 1: Make sense of problems and persevere in solving through reasoning and exploration
- PRI 3: Describe and justify mathematical understandings by constructing viable arguments, critiquing the reasoning of others and engaging in meaningful mathematical discourse.
- PRI 6: Attend to precision.
- PRI 7: Look for and make use of patterns and structure.
- PRI 10: Reflect on mistakes and misconceptions to improve mathematical understanding.

Sequence of  
Instruction

Activities Checklist

## Engage

As a reminder to the previous lesson, ask students to recall the statistics that were calculated on the name-length data. It may help to ask students to look at their work from the previous lesson or you may display the box plots during the discussion.

Ask students to Think-Pair-Share about the following:

- Suppose Chrysanthemum joined our class. How do you think adding Chrysanthemum's name to the girls' data would affect the statistics for that group?

During the "pair" and "share," listen carefully for students' ideas and record their thinking to compare in the closing. Some students may mention that Chrysanthemum is an outlier. If not, pose the questions:

- What is the data point that lies outside most of the other values called?
- Is there a possible outlier? If so, who could it be and why?
- Thinking about the original data, what might have been an outlier and why?

*Teacher's Notes: The purpose of this opener is to hear students' thinking about the situation but not to discuss in length. This question will be revisited in the closing.*

## Explore

PRI 1  
PRI 6

**Note to teacher:** In this activity, students will need to persevere in order to create parallel box plots (on the same number line) and modified box plots (to mark outliers). Mention this terminology to students prior to beginning the task.

Instruct students to find Task #23: Chrysanthemum Joins the Class in the Student Manual. Place students in groups of 2-3. Explain that the students will first add Chrysanthemum to the girls' name-length data and find the summary statistics. The task will then walk students through how to determine whether any outliers are present and use this information to create parallel box plots comparing and contrasting the original girls' data to the new girls' data that includes Chrysanthemum. *Teacher's Note: There should also be modified box plots in which outliers are marked with asterisk.*

Be aware of mistakes that students may make in calculating the summary statistics. It is important that students attend to precision when performing calculations and when labeling the number line for their box plots. Encourage elbow and face partners to check their work on number 2 before moving on. Solutions to Task #23: Chrysanthemum Joins the Class with sample data is provided.

INCLUDED IN THE STUDENT MANUAL

**Task #23: Chrysantehmum Joins the Class**

1. Use this space to record the new girls name-length data set, including Chrysanthemum.

---



---



---

2. Find the summary statistics for the new girls' name-length data and record in the right column. From the previous lesson, record the summary statistics for girls' name-length data (before adding Chrysanthemum).

	Original Girls' Name-Length Data (w/o Chrysanthemum)	New Girls' Name-Length Data (w/ Chrysanthemum)
Minimum		
Quartile 1		
Median		
Quartile 3		
Maximum		
Mean		
Mode		
Range		
Interquartile Range		
Mean Absolute Deviation		

Not for Review Copy  
 Distribution

3. Before creating the box plots, we first need to determine whether or not our data sets contain outliers. One definition of an outlier is any data point that is more than 1.5 times the length of the box away from either the lower or the upper quartiles. First determine if there are outliers in the new data set.

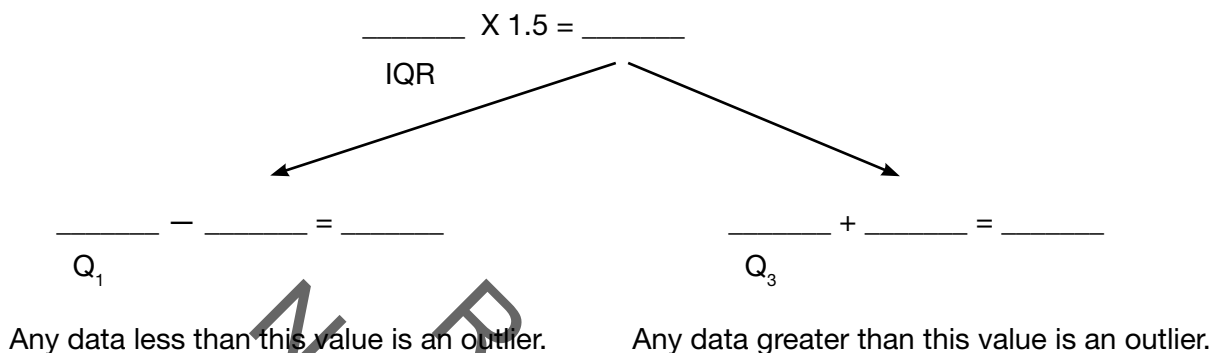

- a). Does the new data contain any outliers? If so, which one(s)?
- b). Use this same process to check for outliers in the original data.
4. Create parallel box plots (box plots that display two different sets of data on the same number line) in order to compare the original data to the new data.

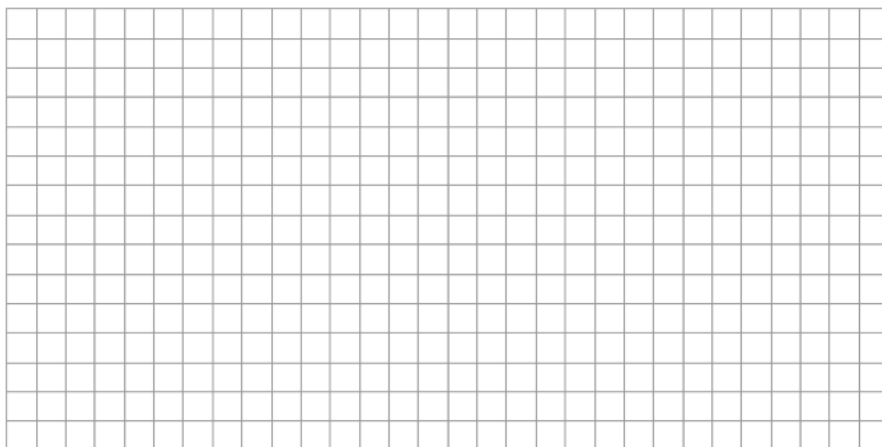

**Chrysanthemum Joins the Class KEY**

1. Use this space to record the new girls' name-length data set, including Chrysanthemum.

6	4	6	3	8
3	5	4	5	3
7	5	8	6	5
5	6	5	6	4
13				

2. Find the summary statistics for the new girls' name-length data set and record in the right column. From the previous lesson, record the summary statistics for girls' name-length data (before adding Chrysanthemum).

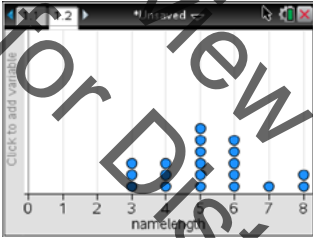
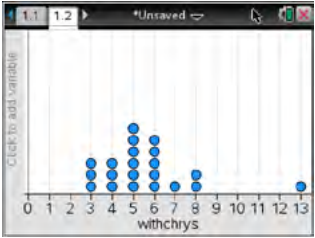
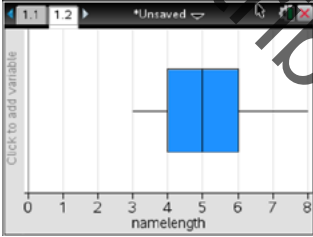
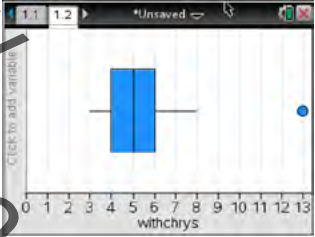
	Original Girls' Name-Length Data (w/o Chrysanthemum)	New Girls' Name-Length Data (w/ Chrysanthemum)
		
		
Minimum	3	3
Quartile 1	4	4
Median	5	5
Quartile 3	6	6
Maximum	8	13
Mean	5.2	5.57
Mode	5	5

Range	5	10
Interquartile Range	2	2
Mean Absolute Deviation	1.15	1.51

3. Before creating the box plots, we first need to determine whether or not our data sets contain outliers. One definition of an outlier is any data point that is more than 1.5 times the length of the box away from either the lower or the upper quartiles. First determine if there are outliers in the new data set.

$$\frac{3}{\text{IQR}} \times 1.5 = \frac{4.5}{\text{IQR}}$$

$$\frac{6}{Q_1} - \frac{4.5}{\text{IQR}} = \frac{1.5}{\text{IQR}} \qquad \frac{7}{Q_3} + \frac{4.5}{\text{IQR}} = \frac{11.5}{\text{IQR}}$$

Any data less than this value is an outlier.      Any data greater than this value is an outlier.

- a). Does the new data contain any outliers? If so, which one(s)?

Yes. Because the data point 13 is greater than 11.5, it is an outlier.

- b). Use this same process to check for outliers in the original data.

There are no outliers in the original data.

4. Create parallel box plots (box plots that display two different sets of data on the same number line) in order to compare the original data to the new data.

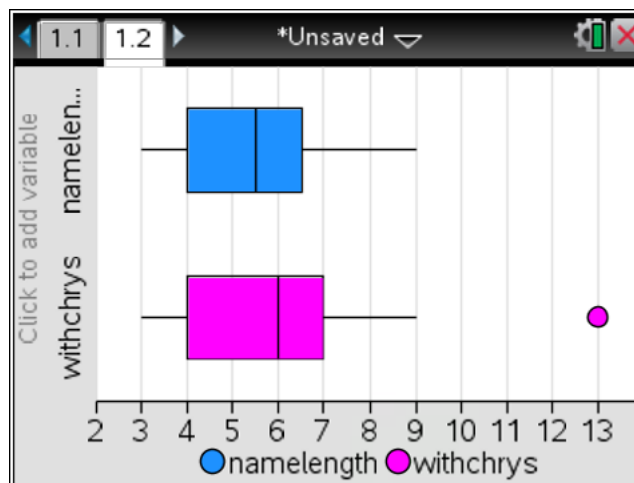

## Explanation

---

**PRI 3**  
**PRI 7**  
**PRI 10**

Now that students have gone through the procedures of calculating summary statistics, determining whether or not there are outliers in the data, and creating parallel box plots, they now need sufficient time to make sense of their findings, consider patterns they noticed, and analyze the results.

Share with students that we must now spend some time analyzing our results and thinking about this overarching question: “What impact can outliers have on the summary statistics of a set of data?” Instruct students to work with their elbow partners to jot down any ideas they have about the following questions:

- Which measure(s) of center were affected by adding Chrysanthemum to the class? Why?
- Which measure(s) of variability (range, IQR, MAD) were affected by adding Chrysanthemum to the class? Why?
- How would you describe the distribution of each set of data? Make sure to discuss center, shape, and spread.

The students will engage with their partners in a discussion of their mathematical reasoning for the questions above. During the small-group discussion time, circulate the room and listen carefully for connections (or misconceptions) that students may be making. Identify students who can share their findings in the whole-group discussion that follows.

Engage students in a whole-group discussion aimed at uncovering misconceptions and sharing discoveries about the effects of outliers on summary statistics.

## Practice Together in Small Groups

---

**PRI 3**

Teacher’s Note: Consider showing students how to use the applet at <http://www.shodor.org/interactivate/activities/BoxPlot/> prior to this part of the lesson.

Students will examine Shodor’s interactive box plots found at <http://www.shodor.org/interactivate/activities/BoxPlot/> with a partner. Students should select one of the following data sets to examine:

- 2004 College ACT Scores
- NBA Team Payrolls in 2004-05
- Horsepower of Cars

Students should describe their mathematical understanding of the distribution in terms of its shape, center, and spread. Encourage students to click on “show statistics” and “uncover outliers” to assist in their interpretations. Each student should individually analyze the statistics and write some observations. Then, partners should critique each other’s statements and work collaboratively to write a final report. If time allows, a second set of data may be examined.

## Evaluate Understanding

---

Instruct students to find Task #24: Lesson 8 - Exit Ticket for this lesson in the Student Manual.

INCLUDED IN THE STUDENT MANUAL

**Task #24: Lesson 8 - Exit Ticket**

Discrimination in the workplace is not always gender discrimination. Former employees of a manufacturing plant have filed a lawsuit against the company claiming they were laid off from their jobs because of age discrimination. The set of data below show the ages of employees who have been laid off from the company in the last year:

28	25	55	64	60
55	56	55	60	59

1. Are any outliers present in the data? Show your mathematical work.
2. How might your results from question #1 help to determine if age discrimination played a role in the company layoffs?

Answers:

1. Both 25 and 28 are outliers. (Students should use  $1.5 \times \text{IQR}$  for these calculations.)
2. This data show that 80% of employees laid off in the last year were 55 or older.

**Closing Activity**

Engage students in a whole-group discussion aimed at summarizing the effects of adding outliers to a set of data. Listen for students to make a connection between the problem in the exit ticket and the third question below where a lower extreme, rather than an upper extreme, is present.

- How do you know if a set of data has an outlier?
- How did adding Chrysanthemum's name to the girls' data affect the statistics for that group?
- How would adding a student named "Jo" to the class affect the data?

**Independent Practice:**

Examine the box plots 2006 Gas Mileage by Car Size and Body Fat Percentages in 2006 and complete the Box Plot Exploration Questions using the links below.

- <http://www.shodor.org/interactivate/activities/BoxPlot/>
- A possible extension can be found at: <http://www.bls.gov/opub/reports/cps/highlights-of-womens-earnings-in-2013.pdf>

**Resources/Instructional Materials Needed:**

- Internet access
- Student computer, laptop, or tablet
- Task #23: Chrysanthemum Joins the Class
- Task #24: Lesson 8 - Exit Ticket
- <http://www.shodor.org/interactivate/activities/BoxPlot/>



## Probability and One-Variable Statistics

# Lesson 9 of 11

## Random Sampling

### Description:

---

Students will collect data on random samples in order to draw inferences about a population.

### College- and Career-Readiness Standard(s) Addressed:

---

- SP.6 Understand that statistics can be used to gain information about a population by examining a sample of the population; generalizations about a population from a sample are valid only if the sample is representative of that population. Understand that random sampling tends to produce representative samples and support valid inferences.
- SP.7 Use data from a random sample to draw inferences about a population with an unknown characteristic of interest. Generate multiple samples (or simulated samples) of the same size to gauge the variation in estimates or predictions.

### Process Readiness Indicator(s) Emphasized:

---

- PRI 1: Make sense of problems and persevere in solving through reasoning and exploration.
- PRI 2: Reason abstractly and quantitatively by using multiple forms of representations to make sense of and understand mathematics.
- PRI 3: Describe and justify mathematical understandings by constructing viable arguments, critiquing the reasoning of others and engaging in meaningful mathematical discourse.
- PRI 4: Contextualize mathematical ideas by connecting them to real-world situations. Model with mathematics.

Sequence of  
Instruction

Activities Checklist

## Engage

### PRI 1

*Teacher's Note:* This lesson can be found at <http://illuminations.nctm.org/Lesson.aspx?id=2528>

Introduce the lesson with a discussion about the following situation:

Scientists often study the health of a habitat by gathering data about the number of animals that live in the area. Suppose you wanted to know how many robins lived in a particular forest.

Students will begin by making sense of the problem. Ask students how they think the number of robins in a forest could be counted. Elicit student responses to questions such as:

- If you tried to gather all of the robins and count them, how would you know if you had indeed counted every single one?
- Do you need to know the exact number of robins?

## Explore

### PRI 2

*Teacher's Note:* In this activity, the students will reason abstractly and quantitatively to make sense of and understand mathematics by simulating a bird capture and tagging study. The activity calls for white beans in cups to represent the bird population. The students are to “capture and tag” the birds by using a marker to mark the initial handful of beans. Alternatively, cracker goldfish may be used in place of beans. Students would “tag” the birds by removing a handful of crackers and replacing them with pretzel goldfish.

Instruct students to complete the Task #25: Capture-Recapture task in the Student Manual.

INCLUDED IN THE STUDENT MANUAL

**Task #25: Capture-Recaptures**

**Population Estimation with Capture and Recapture**

NAME \_\_\_\_\_

The idea behind capture and recapture is:

- Capture and tag some birds in a forest, allowing each of them to go free after being tagged.
- Recapture a set of birds from the forest, and count how many from that set are tagged.
- Use the ratio of tagged birds in your set to generate a proportion. Use the proportion to estimate the total population of birds in the forest.

1. From the cup, CAPTURE a handful of beans. Count the number of beans that you've captured. Mark each of them with a marker. How many beans did you mark? (This number will be important for Questions 8 and 9.)

2. Put the marked beans back in the cup and shake up the cup.

3. From the cup, RECAPTURE a new handful of beans.

How many total beans are in your new handful? \_\_\_\_\_

How many marked beans are in your new handful? \_\_\_\_\_

4. Write a ratio representing  $\frac{\text{marked beans (in handful)}}{\text{total beans (in handful)}}$ . \_\_\_\_\_

5. Fill in the three labeled columns in the first row (across) of the table, using your answers from Questions 3 and 4. (For now, leave the grey column blank; you will fill it in for Question 9.)

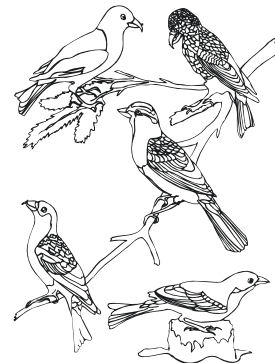

TRIAL NUMBER	NUMBER OF MARKED BEANS	TOTAL NUMBER OF BEANS	RATIO OF MARKED TO TOTAL	
1				
2				
3				
4				
5				
6				

Return the beans to the cup, and then take a new handful as another trial. Record your numbers in the table. Repeat for a total of six trials.

6. Remember, the goal of these trials is to determine \_\_\_\_\_ .

$$\frac{\text{marked beans (in handful)}}{\text{total beans (in handful)}} = \frac{\text{total marked beans (in cup)}}{\text{total number of beans (in cup)}}$$

7. **Using the data from the first trial** and the formula above, write and solve a proportion that can be used to calculate the total number of beans in the cup.

$$\frac{\text{_____}}{\text{_____}} = \frac{\text{_____}}{x}$$

Now, solve this proportion to determine the value of  $x$ .

8. Label the grey column in the table of Question 5 with the title **Estimated Total**. Using each of your other trials (handfuls), **write a proportion and solve it** to estimate the total number of beans in the cup. Each time you calculate a result, enter the value in the grey column of the table in Question 5.
9. Based on your trials, how many beans do you think are in the cup? Why?
10. How does this bean-counting exercise simulate the determination of a population of birds in a forest?
11. What relationship exists between the ratios that appear in the Estimated Total column in the data table of Question 5?

**What is a *reasonable* estimate?**

12. Based on your estimate (your answer to #9 on the last page), what do you think is a reasonable range for the trials? Explain why you chose your range.
13. In the space below, perform enough more experiments so that you have a total of 20 experiments, including the 6 from the first page.

TRIAL NUMBER	NUMBER OF MARKED BEANS	TOTAL NUMBER OF BEANS	RATIO OF MARKED TO TOTAL	

14. Based on what you decided was a reasonable range for the estimates in question #12, look at which of the 20 experiments you did would you consider ‘good’? How many experiments are ‘good’? What percent of your experiments are ‘good’?
15. How many experiments would you think are necessary to assure an accurate overall estimate for the number of robins in the forest? Why?

## Explanation

**PRI 3**  
**PRI 4**

Encourage the students to share their mathematical understandings of the Capture-Recapture real-world simulation activity.

Pose the following questions to the students and facilitate discussion.

1. What strategies did you use to solve this task?
3. How can you choose a random sample?
4. Do you think your estimates were reasonable? How would you know?
5. How can data from a random sample be used to make inferences about a population?

Center this discussion around the importance of random sampling. Explain that in order to gain information about a population, we must examine a sample that is representative of that larger group. Relate this concept back to lesson 2 when students noticed that more trials in the coin toss yielded results closer to theoretical probability. Biased sample selection can produce misleading results and erroneous conclusions. In the opening activity, some students may have based their conclusion on a biased sampling technique. For instance, counting the number of words in a paragraph and then the number of paragraphs on a page could lead to an estimate of total pages that is far from the actual number of pages given that the length of a paragraph can vary greatly within a book.

## Practice Individually

**PRI 4**

Ask students to complete the questions on Task #26: More Practice on Random Sampling in the Student Manual. These questions provide more opportunities for students connect their learning to real-world scenarios.

INCLUDED IN THE STUDENT MANUAL

### Task #26: More Practice on Random Sampling

1. Roxanne wants to estimate the total number of candies in a 1-pound (16 ounce) bag to determine the number of bags she needs to buy for a party. In a 2.5 ounce bag of the same type of candy Roxanne counted 15 candies.
  - a. Estimate the number of candies in a 1-pound bag. Explain your mathematical thinking.
  - b. If Roxanne wants each guest to have 4 pieces of candy and she plans on having about 30 guests, how many 1-pound bags of candy does she need to purchase?
2. A group of biologists wanted to estimate the number of deer in a forest. To begin their study, the tagged and released 100 deer. Later, the captured 800 deer and found that 40 of them were tagged. What is your estimate of the deer population in the forest? Show the work that leads to your answer.

3. Jules studies birds in a nature preserve. To estimate the population of one species of birds, Jules captured and placed a band around the legs of 20 birds. Then, Jules observed 17 banded birds out of a total of 260 birds. Use this information to estimate the population of this bird species in the nature preserve.
4. According to a 2014 survey, 60% of high school students report that they regularly use a smart phone. Based on this survey, how many students would you expect to regularly use a smart phone in a class of 28 students?
5. Anna would like to find out what students in her school think of the new dress code policy. A friend suggests that she set up a survey on a website and invite students to visit the site and answer the questions. Would this be an example of random sampling? Justify your reasoning.

#### More Practice on Random Sampling Answer KEY

1. a. 96 candles  
b. 2 bags
2. 2000 deer
3. 306 birds
4. 17 students
5. Answers will vary, but online surveys are generally not regarded as true random sampling. Some problems with online surveys are that not everyone has internet access, it can be difficult to control who participates in the online survey, and therefore, it is more likely that people that have a vested interest in the outcome of the survey will participate.

#### Evaluate Understanding

Share and discuss student mathematical responses to Task #26: More Practice on Random Sampling. After hearing students' ideas about item 5, pose the following question to students and ask them to justify their reasoning with their partners. Facilitate a whole-group discussion.

- What might be a way to collect information about the dress code policy using random sampling?

#### Closing Activity

Students should submit a Journal Entry given the following prompt:

- What advantages and disadvantages do you see for using random sampling in order to gain information about a population?

Use this entry to address any misconceptions students may have in the next lesson.

#### Resources/Instructional Materials Needed

- Task #25: Capture-Recapture
- Task #26: More Practice on Random Sampling

## Probability and One-Variable Statistics

# Lesson 10 of 11

## Formative Assessment Lesson: Comparing Data Using Statistical Measures

### Description:

---

This lesson unit is intended to help students to make meaningful comparisons between sets of data. In particular, students will develop their abilities to select appropriate measures of center and variability in order to summarize the important features of a set of data and use quantitative measures to justify an argument.

From the Shell Center Formative Assessment Lesson:  
Comparing Data Using Statistical Measures

### College- and Career-Readiness Standard(s) Addressed:

---

- SP Use measures of center and measures of variability for numerical data from random samples to draw informal comparative inferences about two populations. *For example, decide whether the words in a chapter of a seventh-grade science book are generally longer than the words in a chapter of a fourth-grade science book.*

### Process Readiness Indicator(s) Emphasized:

---

- PRI 1: Make sense of problems and persevere in solving through reasoning and exploration
- PRI 2: Reason abstractly and quantitatively by using multiple forms of representations to make sense of and understand mathematics
- PRI 3: Describe and justify mathematical understandings by constructing viable arguments, critiquing the reasoning of others and engaging in meaningful mathematical discourse.
- PRI 4: Contextualize mathematical ideas by connecting them to real-world situations. Model with mathematics.
- PRI 5: Use appropriate tools strategically to support thinking and problem solving.
- PRI 6: Attend to precision.
- PRI 7: Look for and make use of patterns and structure.
- PRI 8: Look for and express regularity in repeated reasoning.
- PRI 9: Demonstrate flexible use of strategies and methods while reflecting on which procedures
- PRI 10: Reflect on mistakes and misconceptions to improve mathematical understanding.

Students will engage in the Formative Assessment Lesson: Comparing Data Using Statistical Measures, which can be found at: <http://map.mathshell.org/download.php?fileid=1658>



The following *Formative Assessment Lesson* is a classroom-ready lesson included to help teachers assess and improve students' understanding of mathematical concepts and skills and their ability to use the mathematical process readiness indicators critical for college readiness.

Research has shown that formative assessment, as embodied in the following lesson, is a powerful way to improve student learning and performance. This approach first allows students to demonstrate their prior understandings and abilities in employing the mathematical processes, and then resolve their own difficulties and misconceptions through structured discussion. This results in more secure long-term learning, reducing the need for re-teaching that otherwise takes so much classroom time.

Many often ask, why don't students just remember the procedures they have been taught and practiced? The fact is, that approach works fine in the short term but, as every teacher knows, if procedural knowledge is not underpinned by conceptual understanding, students will quickly forget "how to do it."

Read more about the *Formative Assessment Lesson* rationale, structure, and philosophy using the *Brief Guide for Teachers and Administrators* that can be found at <http://map.mathshell.org/materials/index.php>.

Review Copy  
Not for Distribution

---

## CONCEPT DEVELOPMENT

---

Mathematics Assessment Project  
**CLASSROOM CHALLENGES**  
A Formative Assessment Lesson

# Comparing Data Using Statistical Measures

Mathematics Assessment Resource Service  
University of Nottingham & UC Berkeley

For more details, visit: <http://map.mathshell.org>  
© 2015 MARS, Shell Center, University of Nottingham  
May be reproduced, unmodified, for non-commercial purposes under the Creative Commons license  
detailed at <http://creativecommons.org/licenses/by-nc-nd/3.0/> - all other rights reserved

## BEFORE THE LESSON

### Assessment task: *Getting James to Work* (20 minutes)

Have the students complete this task, in class or for homework, a few days before the formative assessment lesson. This will give you an opportunity to assess the work and to find out the kinds of difficulties students have with it. You should then be able to target your help more effectively in the subsequent lesson.

Give each student a copy of the assessment task *Getting James to Work*.

Briefly introduce the task, helping the class to understand the problem. You could ask:

- How did you get to school this morning? [E.g. bus, car, train, walk, etc.]*
- Is there more than one feasible way or do you not really have any choice?*

Depending on your school's location, some options may be impossible or unlikely and you may have a lot of or very little variety among the students in your class.

- James has got three options for getting to work. He has written down how long each one took him.*
- How many times did he try going by car? [8.] How did you figure that out?*

These questions are intended to get students examining the data and to help them to see that each number represents a day.

*Use what you notice about the data and the meaning of the numbers listed for bicycles, car, and walk-train-walk to answer the questions on the sheet.*

It is important that, as far as possible, students answer the questions without assistance. If students are struggling to get started, ask questions that help them understand what they are being asked to do, but do not do the problem for them. The first few questions in the *Common issues* table may be helpful.

Students should not worry too much if they cannot understand or do everything, because there will be a lesson related to this, which should help them. Explain to students that by the end of the next lesson they should expect to answer questions such as these confidently; this is their goal.

### Assessing students' responses

Collect students' responses to the task. Make some notes on what their work reveals about their current levels of understanding and their different problem-solving approaches.

We suggest that you do not score students' work. Research suggests that this will be counterproductive, as it will encourage students to compare their scores and distract their attention from what they can do to improve their mathematics. Instead, help students to make further progress by summarizing their difficulties as a series of questions. Some suggestions for these are given in the *Common issues* table on the next page.

**Getting James to Work**

James wants to get to work as quickly and reliably as possible in the mornings.  
 He tries three different transport methods:

- cycle all the way
- drive all the way
- walk to the railway station, take the train, and walk from the station.

He tries each method several times and records how many minutes the entire journey takes:

bicycle	28	24	25	29	25	26	26	23	29	25
car	19	21	32	57	31	27	21	24		
walk-train-walk	21	24	31	26	24	30				

Look carefully at James' results.

1. Use the data to make a case for why he should travel to work by bicycle.  
 .....  
 .....  
 .....
2. Use the data to make a case for why he should travel to work by car.  
 .....  
 .....  
 .....

We recommend that you either:

- write one or two questions on each student’s work, or
- give each student a printed version of your list of questions and highlight the questions for each individual student.

If you do not have time to do this, you could select a few questions that will be of help to the majority of students and write these questions on the board when you return the work to the students in the follow-up lesson.

<b>Common issues</b>	<b>Suggested questions and prompts</b>
<p><b>Does not refer to the data</b>                      For example: The student writes that James should go by bicycle because it is cheaper/better for the environment.</p>	<ul style="list-style-type: none"> <li>• Can you use the data given on the sheet to make your case?</li> </ul>
<p><b>Assumes larger numbers are better</b>                      For example: The student writes that going by car is best because it has the highest mean.</p>	<ul style="list-style-type: none"> <li>• Which is better for James: a higher or a lower mean? Why is this?</li> </ul>
<p><b>Calculates one measure for each method of transport</b>                      For example: The student just uses the mean to support their case.</p>	<ul style="list-style-type: none"> <li>• Can you now consider other measures to support your case?</li> </ul>
<p><b>Refers to only one method of transport</b>                      For example: The student states that James should go by bicycle because the mean time is 26 minutes.</p>	<ul style="list-style-type: none"> <li>• How does this compare with the other methods of transport?</li> </ul>
<p><b>Ignores the outlier in the car data</b>                      For example: The student writes that the mean time by car is 29 minutes.</p>	<ul style="list-style-type: none"> <li>• One car day was very different from all the others. Which one? What could have caused this? What should we do about this value?</li> </ul>
<p><b>Makes a technical error</b>                      For example: The student makes an arithmetic mistake when calculating measures.</p>	<ul style="list-style-type: none"> <li>• Does your answer seem reasonable? How could you check your answers?</li> </ul>
<p><b>Provides two good justifications</b>                      For example: The student justifies travelling by bicycle and by car by making sensible comparisons.</p>	<ul style="list-style-type: none"> <li>• What other factors, apart from this data, might be important for James to consider when deciding how to get to work?</li> </ul>

## SUGGESTED LESSON OUTLINE

### Whole-class introduction (10 minutes)

Give each student a mini-whiteboard, pen, and eraser.

Briefly remind students about the *Getting James to Work* task.

*Do you remember the Getting James to Work task? What was it about?*

*I'm not returning your work to you just yet. That will happen after this lesson.*

*We are going to be doing something similar today and will be using ideas like mean, median, range and outlier.*

Display Slide P-1 showing a list of the four terms:

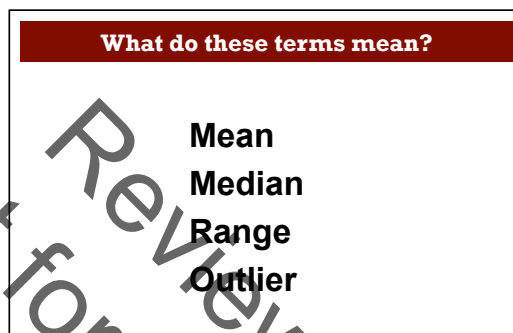

Ask students to say what they understand by each of them:

*What do you know about these terms?*

*How are they useful in making comparisons?*

If students are unsure of their meaning then they could discuss them with each other and write their answers on mini-whiteboards. They will need to be conversant with these terms for the rest of this lesson.

### Collaborative small group work (1): constructing data (35 minutes)

Ask students to work in groups of two or three.

Give each group some blank paper, a pair of scissors, and either *Getting Raj to Work (1)* or *Getting Raj to Work (2)*. (Trials of this unit suggest that students find completing the B1 data table more difficult than completing table A1 so you may wish to use this information when determining which task to give to which group.)

Provide students with a calculator if they do not have one.

Explain to students what they are to do:

*Raj is travelling to work and he can go by bicycle or by car.*

*Your card has some data on it but there is some data missing.*

*At the top of the card someone has written a description of the data and a conclusion about whether Raj should travel to work by bicycle or by car.*

*Your task is to complete the data table so that it fits the description. You are going to use the information given to make up some times to go in the table.*

*You can use a calculator if you need to and there is blank paper available for rough work.*

Display Slide P-2, which summarizes these instructions:

**Collaborative work: constructing data**

1. Use the information given to make up times to go in the table. The times are all in minutes.
2. Check that the data you create fits *all* of the information contained in the description at the top of the card.
3. Consider whether the numbers in the table are reasonable in the given context. Amend any that are not, ensuring that the card *still* fits the description.

While students are working, you have two tasks: to notice student approaches to the task and to support problem solving.

**Make a note of student approaches to the task**

Notice how students make a start on the task, where they get stuck and how they respond if they do come to a halt. Do students start with one component of the description and if so, which measure do they address first? Or do they start by inventing data and hope that it will work? Do they assume that the table must be completed with ten values to match the number already given for the bicycle/car or do they invent less/more data values? Do they write their made-up values in order or do they rearrange the data to check it meets the criteria given in the description? Do they comment on the conclusion of whether Raj should travel by bicycle or by car? You can use this information to focus a whole-class discussion towards the end of the lesson.

**Support student problem solving**

Try not to make suggestions that push students towards a particular approach to the task. Instead, ask questions to help students clarify their thinking.

The following questions and prompts may be helpful:

*Can you check the data that has been given to you on the card? Does it fit the description?*

*Which fact in the description are you going to begin with? Why?*

*Which facts in the description are you going to leave until later? Why?*

If you find students are unproductively struggling for some time you may want to suggest they:

- Find data values that approximately fit the descriptions. This is good enough.
- Or/and create fewer than ten data values.

If students still do not know where to begin, to help them to develop useful strategies you may want to ask:

*Can you write down five numbers with a mean of 10?*

*Can you write down five numbers with a mean of 10 and a median that isn't 10?*

*Can you write down five numbers with a mean of 10 and a median of 10 and one outlier?*

*Can you write down five numbers with a mean of 10 and a range of 3?*

The figures five and ten have been carefully chosen because they are easy numbers to use in division and multiplication. Also an odd number is preferable when calculating the median.

Probe students for the strategies they used to obtain the data values in these simpler cases and see if they can apply these approaches to the information given on the card.

If students are making good progress with the task, encourage them to check that their data values are reasonable in the given context:

*Your values may fit the description, but are they realistic?*

*Can you now change some of them to make them more realistic (but still fit the description)?*

### Extending the lesson over two days

If you are taking two days to complete the unit you might want to end the first lesson here. Then, at the start of the second day, students can swap their data tables and write a description for data generated by another group.

### Collaborative small group work (2): writing descriptions (25 minutes)

When most groups have finished completing their card and you judge that an appropriate amount of time has been spent on the task, stop the class:

*Take your scissors and cut along the dashed line.*

*Swap the **data table** with another group. If you have card A1, swap it with another group's card B1 and vice versa. Keep the top part!*

*Your task now is to write a description of the data that you have just been given. You must refer to the mean, median, and range in your description and comment on any outliers.*

*Try to reconstruct what is written at the top of the card! It won't be exactly the same, but it will be interesting to see the similarities and differences.*

*Once you have completed your description, explain whether you think Raj should travel to work by bicycle or by car.*

Students should write their description on a piece of paper. They can use the top parts of their own cards to remind them of the kinds of things that they might write.

Slide P-3 summarizes these instructions:

**Collaborative work: writing descriptions**

1. Cut along the dashed line.
2. Swap the data table with another group (A1s swap with B1s).
3. Write a description of the data you have just been given. Refer to the mean, median and range and comment on any outliers. (It may not match exactly what it said on that card!).
4. Explain whether you think Raj should travel to work by bicycle or by car.

### Collaborative small group work (3): comparison of descriptions (20 minutes)

Once the students have written their descriptions and come to a conclusion about which mode of transport Raj should use, they should pair up with the group whose data they were using and compare what they have written with the descriptions on the card.

*See what the similarities and differences are between what you wrote and what it said on the card. Maybe what you wrote was better?*

*Check whether you came to the same conclusion about which mode of transport Raj should use.*

Some differences will be due to focusing on different aspects of the data; others may be due to errors on the part of the group constructing the data. Encourage students to identify errors and think about any revisions that may be required.

**Whole-class discussion (20 minutes)**

In a whole-class discussion, depending on how the lesson went, encourage students to talk about what they have learned, strategies they used and/or what differences arose during the comparison of descriptions and conclusions.

Questions you might like to ask about strategies used to create data sets:

*When figuring out the data values, what measure did you work with first? Why was that? Then what did you do?*

*Did anyone use a different strategy?*

*What difficulties did you encounter? Did you overcome these difficulties? How?*

Encourage students to reflect on the decisions they made when generating the data, for example students working on the same descriptions may have chosen to use a contrasting number of data values to complete the table:

*Sarah, what data values did you use to complete the Car/Bicycle times for A1/B1?*

*Matthew, what values did you have for A1/B1?*

*Do both sets of data match the description?*

*Why can we have different data values that both satisfy the same description?*

*Did we need to complete the data table with 10 values? Why / Why not?*

Questions you might like to ask about writing and comparing descriptions:

*How close were your descriptions to the ones on the card?*

*Did you come to the same conclusions?*

*Why do you think that was?*

*What were the differences? Were they significant? Why?*

**Follow-up lesson: reviewing the assessment task (30 minutes)**

Begin by returning to the students the initial assessment task *Getting James to Work*. If you have chosen not to write questions on individual student papers, display your list of questions on the board.

*Here are my comments on the work you did [a few days ago]. Working individually, consider your responses to my questions and how you could improve your work. Write your responses on the back if there isn't space on the task sheet.*

Give students a copy of the task *Running Times*.

*Now, see if you can use what you have learnt last lesson to complete this similar task.*

Teachers may prefer to give this as a homework task.

**Extension task**

If you feel that your class needs further practice at this kind of activity, then two extension cards have also been provided: *Getting Raj to work – Extension (1) and (2)*. These are more open and students find them more difficult.



## SOLUTIONS

### Assessment task: *Getting James to Work*

The statistics in the table below may help you to interpret students' answers:

	<b>Bicycle</b>	<b>Car</b>	<b>Walk-train-walk</b>	<b>Car (with outlier omitted)</b>
<b>Mean</b>	26	29	26	25
<b>Median</b>	25.5	25.5	25	24
<b>Range</b>	6	38	10	13
<b>Standard Deviation</b> (correct to 2 decimal places)	2.05	12.27	3.85	5.13
<b>Mean Absolute Deviation</b> (correct to 2 decimal places)	1.6	8.25	3	4.29

Given the small amount of data and the similarity in the mean values, students may feel that there is not much difference and little basis for a firm conclusion. These are important issues for them to consider.

The following comments on each question are for guidance only:

1. The case for going by bicycle could draw on the fact that the mean is the (joint) smallest, coupled with the fact that the spread of the data is less. This means that James can be more confident of the time that it will take him to get to work, as the values are more consistent.

Students might also comment on the cheaper cost and environmental and fitness benefits of cycling, the ease with which he can speed past traffic jams and the possibility that after weeks of cycling to work he may be able to make the journey even more quickly, as he gets fitter. These are not arguments based on the data, however.

2. The case for going by car initially looks weak, as the mean is higher than for the other modes of transport and the data is also spread out, making the journey time very variable and this method quite unreliable. However, much of this is caused by the one outlier of 57 minutes. Perhaps this was caused by a freak traffic jam? Without knowing how often such events occur, students might be unsure what to do with this data item. Omitting it gives the results in the right-hand column of the table above, giving car travel the smallest mean time. However, there remains the unquantified risk of the occasional very long journey time. Even though there is no clear-cut rule about what to do with outliers, students should be aware of the problem and should certainly comment on a clear outlier such as this.

**Collaborative small-group work**

Possible data values are shown in the table below. Other values would also work. The mean, median and range are also shown in the table:

	Mode of transport	Data ( <i>values in italics already given</i> )										Mean	Median	Range
A1	Bicycle	25	<i>22</i>	<i>26</i>	<i>23</i>	<i>28</i>	<i>23</i>	<i>25</i>	<i>27</i>	<i>24</i>	<i>27</i>	<b>25</b>	<b>25</b>	<b>6</b>
	Car	21	<i>21</i>	<i>22</i>	<i>22</i>	<i>22</i>	<i>24</i>	<i>26</i>	<i>26</i>	<i>26</i>	<i>40</i>	<b>25</b>	<b>23</b>	<b>19</b>
B1	Bicycle	12	<i>12</i>	<i>13</i>	<i>13</i>	<i>25</i>	<i>25</i>	<i>25</i>	<i>25</i>	<i>25</i>	<i>25</i>	<b>20</b>	<b>25</b>	<b>13</b>
	Car	20	<i>24</i>	<i>24</i>	<i>20</i>	<i>18</i>	<i>24</i>	<i>20</i>	<i>16</i>	<i>20</i>	<i>24</i>	<b>21</b>	<b>20</b>	<b>8</b>

If students have made minor calculation errors, or have managed to satisfy only some of the conditions in the descriptions, it is important to value what they have achieved and learned from the task, even if they have not completed it perfectly.

**Extension task**

	Mode of transport	Data ( <i>values in italics already given</i> )										Mean	Median	Range
A2	Bicycle	18	<i>18</i>	<i>19</i>	<i>19</i>	<i>20</i>	<i>20</i>	<i>20</i>	<i>20</i>	<i>21</i>	<i>25</i>	<b>20</b>	<b>20</b>	<b>7</b>
	Car	14	<i>16</i>	<i>19</i>	<i>22</i>	<i>22</i>	<i>24</i>	<i>25</i>	<i>25</i>	<i>26</i>	<i>27</i>	<b>22</b>	<b>23</b>	<b>13</b>
B2	Bicycle	17	<i>18</i>	<i>19</i>	<i>23</i>	<i>24</i>	<i>26</i>	<i>27</i>	<i>28</i>	<i>29</i>	<i>29</i>	<b>24</b>	<b>25</b>	<b>12</b>
	Car	24	<i>24</i>	<i>25</i>	<i>25</i>	<i>25</i>	<i>31</i>	<i>36</i>	<i>37</i>	<i>48</i>		<b>30</b>	<b>25</b>	<b>24</b>

**Assessment task: Running Times**

The statistics in the table below may help you to interpret students' answers:

	Mary	David	Sally	David ( <i>with outlier omitted</i> )
<b>Mean</b>	63	64	64	62
<b>Median</b>	65	62	64.5	62
<b>Range</b>	12	27	3	5
<b>Standard Deviation</b> ( <i>correct to 2 decimal places</i> )	3.98	7.15	1.25	1.84
<b>Mean Absolute Deviation</b> ( <i>correct to 2 decimal places</i> )	3.5	3.67	1	1.45

1. The case for not entering Sally into the race could draw on the fact that the mean is the (joint) highest, coupled with the fact that the median is the second highest out of the 3 runners. The spread of the data is less than the other two runners, suggesting that Sally is running consistently at these times. Comparing Sally's race time with David's (who has a comparable mean), even when the outlier in David's data is removed, Sally's running times are still more consistent.

Students might also comment on the fact that there is less data for Sally than the other two runners. They may conclude that Sally is unreliable and so should not be entered into the race. This argument is not, however, based explicitly on the data.

2. The case for not entering Mary into the race may initially look weak, as the mean is lower than for the other runners and the times are more consistent than David's (although not as consistent as Sally's). However, the very high range of running times for David is caused by the one outlier of 86 minutes. Perhaps David was not feeling well on this occasion or injured himself during the training session? Without knowing how often such events occur, students might be unsure what to do with this data item. Omitting it gives the results in the right-hand column of the table above, giving David the smallest mean time, bettering Mary's mean of 63. However, there remains the un-quantified risk of the occasional very long run time. Even though there is no clear-cut rule about what to do with outliers, students should be aware of the problem and should certainly comment on a clear outlier such as this.

Not for Review Copy  
Not for Distribution

## Getting James to Work

James wants to get to work as quickly and reliably as possible in the mornings.

He tries three different transport methods:

- cycle all the way
- drive all the way
- walk to the railway station, take the train, and walk from the station.

He tries each method several times and records how many minutes the entire journey takes:

bicycle	28	24	25	29	25	26	26	23	29	25
car	19	21	32	57	31	27	21	24		
walk-train-walk	21	24	31	26	24	30				

Look carefully at James' results.

1. Use the data to make a case for why he should travel to work by bicycle.

.....

.....

.....

.....

.....

.....

.....

.....

2. Use the data to make a case for why he should travel to work by car.

.....

.....

.....

.....

.....

.....

.....

.....

## Getting Raj to Work (1)

**A1**

**Description:**

The mean times by car and by bicycle are the same.

The median car time is 23 minutes, whereas the median bicycle time is 25 minutes.

The range of bicycle times is 6 minutes, whereas the range of car times is only 5 minutes, if you exclude the outlier.

**Conclusion:**

Raj should go by car.

Use the description to complete the data table below:

**A1**

Bicycle times	25	22	26	23	28	23	25	27	24	27
Car times										

## Getting Raj to Work (2)

### B1

#### Description:

The mean time by bicycle is 1 minute less than the mean time by car.

The median time by bicycle is 5 minutes more than the median time by car.

The range of car times is 8 minutes, which is 5 minutes less than the range of bicycle times.

#### Conclusion:

Raj should go by car.

Use the description to complete the data table below:

### B1

Bicycle times										
Car times	20	24	24	20	18	24	20	16	20	24

## Running Times

An athletics coach is training three runners Mary, David and Sally to compete in a 10-kilometer race.

He can only enter two of the runners and needs to decide which runner will not be entered.

He knows how many minutes it has taken each runner to run 10 kilometers in their training sessions:

Mary	70	58	58	65	59	60	66	59	65	65	66	65
David	62	60	60	64	86	64	64	61	59	62	64	62
Sally	65	63	62	64	62	65	65	65	65	64		

Look carefully at the coach's results.

1. Use the data to make a case for why he should not enter Sally into the race.

.....

.....

.....

.....

.....

.....

.....

.....

2. Use the data to make a case for why he should not enter Mary into the race.

.....

.....

.....

.....

.....

.....

.....

.....

## Getting Raj to Work - Extension (1)

**A2**

**Description:**

The mean is 2 minutes less by bicycle.

The median is 3 minutes less by bicycle.

The range by bicycle is also less, so travelling by bicycle is more consistent from day to day.

**Conclusion:**

Raj should go by bicycle.

Use the description to complete the data table below:

**A2**

Bicycle times
Car times



## Getting Raj to Work - Extension (2)

**B2**

**Description:**

The mean time by bicycle is four-fifths of the mean time by car.

There is an outlier in the car times, but even if you exclude that, the mean time by bicycle is 4 minutes less.

The median times by car and by bicycle are the same.

**Conclusion:**

Raj should go by car.

Use the description to complete the data table below:

**B2**

Bicycle times
Car times

# What do these terms mean?

**Mean**

**Median**

**Range**

**Outlier**

Not for Review or Distribution

## Collaborative work: constructing data

1. Use the information given to make up times to go in the table. The times are all in minutes.
2. Check that the data you create fits *all* of the information contained in the description at the top of the card.
3. Consider whether the numbers in the table are reasonable in the given context. Amend any that are not, ensuring that the card *still* fits the description.

## Collaborative work: writing descriptions

1. Cut along the dashed line.
2. Swap the data table with another group (A1s swap with B1s).
3. Write a description of the data you have just been given. Refer to the mean, median and range and comment on any outliers. (It may not match exactly what it said on that card!).
4. Explain whether you think Raj should travel to work by bicycle or by car.

## Mathematics Assessment Project **Classroom Challenges**

These materials were designed and developed by the  
Shell Center Team at the Center for Research in Mathematical Education  
University of Nottingham, England:

**Malcolm Swan,**  
**Nichola Clarke, Clare Dawson, Sheila Evans, Colin Foster, and Marie Joubert**  
with  
**Hugh Burkhardt, Rita Crust, Andy Noyes, and Daniel Pead**

We are grateful to the many teachers and students, in the UK and the US,  
who took part in the classroom trials that played a critical role in developing these materials

The classroom observation teams in the US were led by  
**David Foster, Mary Bouck, and Diane Schaefer**

This project was conceived and directed for  
The Mathematics Assessment Resource Service (MARS) by  
**Alan Schoenfeld** at the University of California, Berkeley, and  
**Hugh Burkhardt, Daniel Pead, and Malcolm Swan** at the University of Nottingham

Thanks also to Mat Crosier, Anne Floyde, Michael Galan, Judith Mills, Nick Orchard, and Alvaro Villanueva who contributed to the design and production of these materials

This development would not have been possible without the support of  
**Bill & Melinda Gates Foundation**

We are particularly grateful to  
**Carina Wong, Melissa Chabran, and Jamie McKee**

The full collection of Mathematics Assessment Project materials is available from

<http://map.mathshell.org>

© 2015 MARS, Shell Center, University of Nottingham  
This material may be reproduced and distributed, without modification, for non-commercial purposes,  
under the Creative Commons License detailed at <http://creativecommons.org/licenses/by-nc-nd/3.0/>  
All other rights reserved.  
Please contact [map.info@mathshell.org](mailto:map.info@mathshell.org) if this license does not meet your needs.

## Probability and One-Variable Statistics

# Lesson 11 of 11

## A Simulation of Gender Discrimination

### Description:

---

Students will conduct a simulation to make an informed decision about the gender discrimination problem. After creating a dot plot of the simulation data, students will analyze the data and interpret the results. This culminating activity will require students to communicate their interpretation of the results using appropriate statistical language.

### College- and Career-Readiness Standard(s) Addressed:

---

- SP.4 Display numerical data in plots on a number line, including dot plots, histograms, and box plots.
- SP.5 Summarize numerical data sets in relation to their context, such as by:
  - Reporting the number of observations.
  - Describing the nature of the attribute under investigation, including how it was measured and its units of measurement
  - Giving quantitative measures of center (median and/or mean) and variability (interquartile range and/or mean absolute deviation), as well as describing any overall pattern and any striking deviations from the overall pattern with reference to the context in which the data were gathered.
- SP.6 Understand that statistics can be used to gain information about a population by examining a sample of the population; generalizations about a population from a sample are valid only if the sample is representative of that population. Understand that random sampling tends to produce representative samples and support valid inferences.
- SP.7 Use data from a random sample to draw inferences about a population with an unknown characteristic of interest. Generate multiple samples (or simulated samples) of the same size to gauge the variation in estimates or predictions. For example, estimate the mean word length in a book by randomly sampling words from the book; predict the winner of a school election based on randomly sampled survey data. Gauge how far off the estimate or prediction might be.
- SP.9 Use measures of center and measures of variability for numerical data from random samples to draw informal comparative inferences about two populations. *For example, decide whether the words in a chapter of a seventh-grade science book are generally longer than the words in a chapter of a fourth-grade science book.*

### Process Readiness Indicator(s) Emphasized:

---

- PRI 1: Make sense of problems and persevere in solving through reasoning and exploration

- PRI 3: Describe and justify mathematical understandings by constructing viable arguments, critiquing the reasoning of others and engaging in meaningful mathematical discourse.
- PRI 4: Contextualize mathematical ideas by connecting them to real-world situations. Model with mathematics.
- PRI 6: Attend to precision.
- PRI 7: Look for and make use of patterns and structure.

Sequence of Instruction

Activities Checklist

Engage

PRI 1

*Teacher's Note: In this lesson to make sense of this problem, students will revisit the scenario studied in Lesson 1 involving possible gender discrimination of applicants by bank supervisors. Students will conduct a simulation and analyze data in order to answer the statistical question being asked: "Was there gender discrimination of female applicants by bank supervisors?"*

Ask students to recall the two-way tables they created in Lesson 1. Display the table for students to view or ask them to turn back to Lesson 1 in the Student Manual.

No discrimination by gender			
	Recommended for Promotion	Not Recommended for Promotion	Total
Male			24
Female			24
Total	35	13	48

In one of the two-way tables, students were asked to provide possible values if no gender discrimination were present. In the Explore part of Lesson 1, it was advised to take note of the variability that students deem as "acceptable" when no discrimination is practiced. If you have this information, share it with students and ask them to discuss in their groups.

- Do you still agree with your "acceptable" range or would you make adjustments based on your experience with variability in this unit? Why or why not?

If you did not record this information, provide students a couple of minutes to discuss.

- What number of males recommended for promotion is "acceptable" if no discrimination is practiced?

Students should expect the number of males recommended for promotion when no discrimination is practiced to be around 17 or 18. Many will likely feel comfortable if those numbers are expanded to 16 or 19 males, but there is often uncertainty beyond these values.

Share with students that the simulation we conduct in today's lesson will be based on an assumption that no discrimination is being practiced. This process will allow us to give a more mathematically sound answer to our statistical question.

## Explore

**PRI 3**  
**PRI 4**  
**PRI 6**  
**PRI 7**

In this lesson, students will use a tool commonly used by researchers to gain insight into the discrimination problem. Researchers often do not have the opportunity to repeat a study many times, but simulation can allow them to model a situation and investigate what would happen if they could repeat the study many times. By allowing students to gather information about the variability that can result by chance when there is no discrimination, the simulation prepares them to use statistical reasoning to determine if discrimination against women did indeed occur.

Divide students into nine groups of 2-4 students. Explain each group will conduct 10 simulations of the real world discrimination scenario and will then combine their data with two other groups to analyze a data set of 30. In the end, approximately 90 simulations should occur. Directions for the simulation are provided in Task #27: Simulating the Discrimination Case in the Student Manual. It may be helpful to demonstrate a simulation with a deck of cards in a whole-group setting. After explaining the directions and/or demonstrating a simulation, ask students to consider the following questions:

- Before beginning the simulation, what would you expect for the shape of the distribution you create in the dot plot?
- At what value would you expect the distribution to be centered?

Explain to students they should stop after item 5 in their Student Manual and wait for teacher directions before moving on. Instruct students to begin the task.

### INCLUDED IN THE STUDENT MANUAL

#### Task #27: Simulating the Discrimination Case

Using a deck of cards, let 24 black cards represent the male candidates for promotion and 24 red cards represent the females (remove 2 red cards and 2 black cards from the deck). This will simulate the 48 folders, half of which were labeled male and the other half female.

1. Shuffle the 48 cards thoroughly to insure that the cards counted out are from a random process. You are simulating what can happen with random variation where no discrimination is being practiced.
2. Count out the top 35 cards. These cards represent the applicants recommended for promotion to bank manager. (You may wish to count out 13 cards that will not be considered for a quicker count).
3. Of the 35 cards, count the number of black cards (representing the males).
4. On the number line below, create a dot plot by recording the number of black cards of the 35 counted (the number of men recommended for promotion if there were no discrimination present).



- Repeat steps 1 – 4 nine more times for a total of 10 simulations.



**Number of Men Promoted**

- Combine data from your 10 simulations with data from two other groups. Record the data on your dot plot above for a total of 30 data.
- Work with your small group to analyze the data. You should use the dot plot to report on the shape, center, and variability of the distribution of the data. After interpreting the results of your analysis, be sure to draw conclusions by revisiting the statistical question being studied: Is there gender discrimination of female applicants by bank supervisors?

Observe students as they create their dot plot making sure they are attending to precision as they label the number line. Students should realize that the range of possible men recommended for promotion is from 11 to 24.

After all groups have conducted their 10 simulations and recorded their data on the dot plot, instruct 3 groups to combine their data on one dot plot displayed on chart paper. For example, 3 groups of students should have a total of 30 simulations combined on one dot plot. If there are 9 groups total, then there should be three dot plots of 30 data each for students to view.

After students have created the dot plots on chart paper with their other two groups, ask them to copy this data onto their dot plot in the student manual.

Students should work in their original small groups on item 7. This will allow students to use a variety of different skills addressed in this unit, but most importantly, it gives them a chance to interpret their results and communicate using statistical terms. Ultimately, they are asked to reach a mathematical conclusion about the statistical question but they must do so by reporting on the shape, center, and spread of the data. Although students will discuss the results with members of their group, the summary provided in item 7 should be completed individually. It is important each student is able to communicate their findings using statistical language. A calculator will be helpful in analyzing the data.

Students may need to be reminded that in earlier discussions, we had no mathematics to support what we considered to be an acceptable range, but now we must answer the question based on the results of the simulations performed. In general, and without getting too deep into higher level statistics, students can use what are known as confidence intervals, although it is not necessary for them to fully understand or use this terminology. Using a 95% confidence interval, if the dot plot of the simulations show that the result (in this case 21 out of 35 recommended for promotion were male) occurred less than 5% of the time, it is statistically significant. If the result occurred more than 5% of the time, it could occur randomly. Keep this in mind throughout the following class discussion.

## Explanation

Select several groups to present. Look for a couple of good responses that are very different in their explanations. If there was a common misconception amongst the students, perhaps a comparison of two students' work — one with a sufficient explanation and the other that illustrates the misconception — would help to bring this to the forefront.

Every class will have different results due to the data collection process, thus, the conversation in your class must be centered on your students' data. On the next page is a sample dot plot for this situation and some observations that students might make.

- The shape of the distribution is fairly symmetrical with the exception of one value at 22 which could be an outlier.
- The mean is 17.6, which is very close to 17.5—our expected number of males promoted.
- The values range from 15 to 22 but most fall between 16 and 19.
- The variability can be measured by the interquartile range which is 2 or the mean absolute deviation which is 1.2 males.
- The distribution matches our earlier prediction that the data would be centered around 17 with only 1 out of 20 values falling outside of the 16 to 19 range.
- The results of the simulation do seem to support the notion that the promotion of 21 males could be due to gender discrimination.

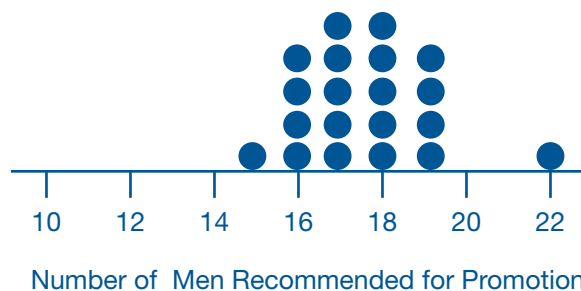

## Practice Individually

*Teacher's Note: This task was adapted from*  
<https://www.illustrativemathematics.org/content-standards/tasks/942>

Ask students to work individually on the Task #28: Haircut Costs in the Student Manual. This task will give students an opportunity to practice using statistical language to communicate about the shape, center, and spread of a distribution.

INCLUDED IN THE STUDENT MANUAL

### Task #28: Haircut Costs

Seventy-five female college students and 24 male college students reported the cost (in dollars) of her or his most recent haircut. The resulting data are summarized in the following table.

	Females	Males
No. of Observations	75	24
Minimum	0	0
Maximum	150	35
1st Quartile	20	9.25
Median	31	17
3rd Quartile	75	20
Mean	52.53	20.13

- a. Using the minimum, maximum, quartiles, and median, sketch two side-by-side box plots to compare the hair cut costs between males and females in this student's school.



- b. How would you describe the difference in haircut costs between males and females? Be sure you discuss differences/similarities in shape, center, and spread.

**Task #28: Haircut Costs KEY**

- a. Students can sketch out a basic box plot with whiskers extending to the min and max, a box extending from the first quartile to the third quartile, and a line at the median, as shown below. In order to compare haircut costs of males and females, the two boxplots should be plotted side by side on the same scale.

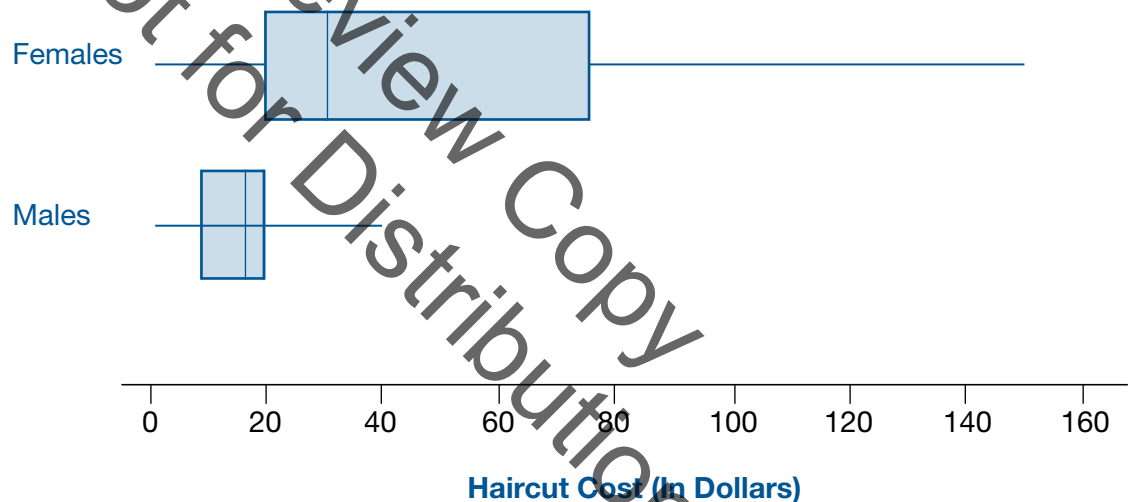

- b. Both boxplots show distributions that are skewed to the right. It makes sense that most haircuts will not cost too much, but a few students will spend a large amount. Since the cost will always be a positive number, the minimum cannot be less than 0 and there is a long right tail. The centers and spreads are quite different. The median cost for females is about twice that of males, and there is much more variability in the haircut costs for women. The interquartile range (IQR) for women is \$55, while for men it is \$10.75.

## Evaluate Understanding

Ask students to complete the Task #29: Lesson 11 - Exit Ticket for this lesson in the Student Manual. Use this information to address any misconceptions or final questions students may have prior to the unit assessment.

INCLUDED IN THE STUDENT MANUAL

### Task #29: Lesson 11 - Exit Ticket

	What I understand about...	What questions I still have about...
Shape		
Center		
Spread		

## Closing Activity

### PRI 3

Facilitate a whole-group discussion where students will communicate their mathematical understandings of the Unit 3 Essential Questions.

- How is the likelihood of an event determined and communicated?
- What types of questions will result in statistical variability?
- How can you determine the best measure of center and the best measure of variability for a data set?
- How can we use mathematics to provide models that help us interpret data, make predictions, and better understand the world in which we live, and what are the limits of these models?

## Resources/Instructional Materials Needed:

- A deck of cards for each group of students
- Calculator
- Task #27: Simulating the Discrimination Case
- Task #28: Haircut Costs
- Task #29: Lesson 11 - Exit Ticket

# SREB

## SREB Readiness Courses

# Ready for High School: Math

### Math Unit 4

### Expressions, Equations and Inequalities

Not for Review Copy Distribution

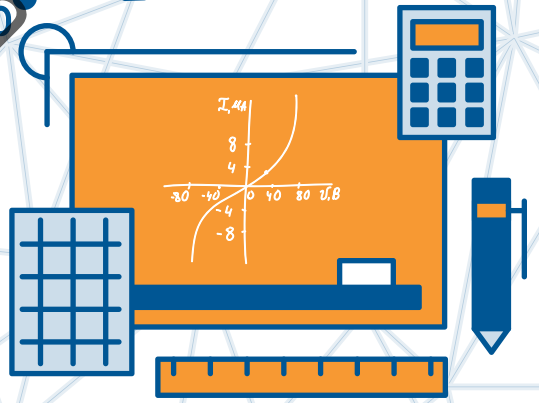

Southern  
Regional  
Education  
Board

592 Tenth Street, NW  
Atlanta, GA 30318  
(404) 875-9211

[www.sreb.org](http://www.sreb.org)

## Unit 4 . Expressions, Equations and Inequalities

### Overview

In this unit students will:

- Translate verbal phrases and situations into algebraic expressions
- Use properties to identify equivalent expressions
- Use properties and mathematical models to generate equivalent expressions
- Determine if an equation or inequality is appropriate for a given situation
- Solve mathematical and real world problems with equations and inequalities
- Represent real-world situations with equations and inequalities
- Interpret the solutions to equations and inequalities

Experiences in creating expressions and solving equations will require students to understand the meaning and structure of expressions and equations, as well as being able to answer the question being asked. The use of illustrations, drawings, and models to represent and solve equations and inequalities will help students develop understanding of the solutions of equations and inequalities. As effective strategies for solving equations and inequalities are developed, students will extend these strategies to literal equations.

### Essential Questions:

- *How can you extend the properties of operations on numerical expressions to algebraic expressions?*
- *What is the difference in an expression and an equation?*
- *What strategies can I use to help me understand and represent real situations using expressions, equations and inequalities?*

## College- and Career-Readiness Standards:

---

- EE.1 Write, read, and evaluate expressions in which letters stand for numbers.
  - Identify parts of an expression using mathematical terms (sum, term, product, factor, quotient, coefficient); view one or more parts of an expression as a single entity. *For example, describe the expression  $2(8 + 7)$  as a product of two factors; view  $(8 + 7)$  as both a single entity and a sum of two terms.*
  - Evaluate expressions at specific values of their variables. Include expressions that arise from formulas used in real-world problems. Perform arithmetic operations, including those involving whole number exponents, in the conventional order when there are no parentheses to specify a particular order (Order of Operations). *For example, use the formulas  $V = s^3$  and  $A = 6s^2$  to find the volume and surface area of a cube with sides of length  $s = \frac{1}{2}$ .*
- EE.2 Apply the properties of operations to generate equivalent expressions. *For example, apply the distributive property to the expression  $3(2 + x)$  to produce the equivalent expression  $6 + 3x$ ; apply the distributive property to the expression  $24x + 18y$  to produce the equivalent expression  $6(4x + 3y)$ ; apply properties of operations to  $y + y + y$  to produce the equivalent expression  $3y$ .*
- EE.3 Identify when two expressions are equivalent (i.e., when the two expressions name the same number regardless of which value is substituted into them). *For example, the expressions  $y + y + y$  and  $3y$  are equivalent because they name the same number regardless of which number  $y$  stands for.*
- EE.4 Use variables to represent numbers and write expressions when solving a real-world or mathematical problem; understand that a variable can represent an unknown number, or, depending on the purpose at hand, any number in a specified set.
- EE.6 Understand that rewriting an expression in different forms in a problem context can shed light on the problem and how the quantities in it are related. *For example,  $a + 0.05a = 1.05a$  means that “increase by 5%” is the same as “multiply by 1.05.”*
- EE.7 Solve multi-step real-life and mathematical problems posed with positive and negative rational numbers in any form (whole numbers, fractions, and decimals), using tools strategically. Apply properties of operations to calculate with numbers in any form; convert between forms as appropriate; and assess the reasonableness of answers using mental computation and estimation strategies.
- EE.8 Use variables to represent quantities in a real-world or mathematical problem, and construct simple equations and inequalities to solve problems by reasoning about the quantities.
- EE.9 Know and apply the properties of integer exponents to generate equivalent numerical
- EE.14 Solve linear equations in one variable.
  - Give examples of linear equations in one variable with one solution, infinitely many solutions, or no solutions. Show which of these possibilities is the case by successively transforming the given equation into simpler forms, until an equivalent equation of the form  $x = a$ ,  $a = a$ , or  $a = b$  results (where  $a$  and  $b$  are different numbers).

- Solve linear equations with rational number coefficients, including equations whose solutions require expanding expressions using the distributive property and collecting like terms.
- A1 Interpret expressions that represent a quantity in terms of its context.
  - Interpret complicated expressions by viewing one or more of their parts as a single entity. For example, interpret  $P(1+r)^n$  as the product of  $P$  and a factor not depending on  $P$ .
- A2 Choose and produce an equivalent form of an expression to reveal and explain properties of the quantity represented by the expression.
- A3 Explain each step in solving a simple equation as following from the equality of numbers asserted at the previous step, starting from the assumption that the original equation has a solution. Construct a viable argument to justify a solution method.
- A.4 Solve linear equations and inequalities in one variable, including equations with coefficients
- A.5 Rearrange formulas to highlight a quantity of interest, using the same reasoning as in solving equations. For example, rearrange Ohm's law  $V = IR$  to highlight resistance  $R$ .

#### Prior Scaffolding Knowledge / Skills:

---

- Use square root and cube root symbols to represent solutions to equations of the form  $x^2 = p$  and  $x^3 = p$ , where  $p$  is a positive rational number. Evaluate square roots of small perfect squares and cube roots of small perfect cubes. Know that  $\sqrt{2}$  is irrational.
- Know the formulas for the area and circumference of a circle and use them to solve problems; give an informal derivation of the relationship between the circumference and area of a circle.
- Use facts about supplementary, complementary, vertical, and adjacent angles in a multi-step problem to write and solve simple equations for an unknown angle in a figure.



### Lesson Progression Overview:

Lesson Big Idea	Lesson Details	Content Standards	Process Readiness Indicators
<b>Lessons 1 and 2: Entry Event Lesson: Sam's Diner</b>	This task was adapted from the online article <i>Dr. Seuss Comes to Math Class</i> by Carrie DeFrancisco (as published by Math Solutions in Online Newsletter Issue 1, Spring 2001). Centered around the classic Dr. Seuss book <i>Green Eggs and Ham</i> , the author helps students explore mathematical content such as representing quantities with variables, simplifying expressions, interpreting expressions and equations, and solving one and multi-step equations by using the menu from Sam's Diner, Dr. Seuss's favorite restaurant, to decode orders and determine the total amount of each order.	EE.1 EE.4 EE.6 EE.7 EE.8 A.1 A.2 A.3	PRI 1 PRI 2 PRI 3 PRI 4 PRI 6 PRI 7 PRI 8
<b>Lessons 3 and 4: Creating Expressions</b>	Students will be asked to create expressions (in context) from a verbal description, and explore the relationship between numerical and algebraic expressions.	EE.1 EE.4 EE.7	PRI 2 PRI 3 PRI 6 PRI 7 PRI 8
<b>Lesson 5: Identifying Equivalent Expressions and Equations</b>	Students will be asked to create and interpret equivalent expressions. They will examine how symbolic manipulation of expressions affects values in real circumstances. Students will also explore a real-life problem that includes some basic geometric concepts along with expression manipulation.	EE.2 EE.3 EE.6 EE.7 EE.9 A.1 A.2	PRI 2 PRI 3 PRI 4 PRI 9
<b>Lesson 6: Formative Assessment Lesson: Interpreting Algebraic Expressions</b>	This lesson is intended to help assess how well students are able to translate between words, symbols, tables, and area representations of algebraic expressions.	A.1 A.2	PRI 1 PRI 2 PRI 4 PRI 5 PRI 6 PRI 7 PRI 8 PRI 9 PRI 10
<b>Lesson 7: Creating Equations</b>	Students will be asked to create equations (in context) from a verbal description. Students will also create and examine equivalent equations, and explore the idea of when a solution exists or does not exist. Students will represent and solve real-world problems with expressions and equations.	EE.8 EE.14 A.4	PRI 1 PRI 2 PRI 3 PRI 6
<b>Lesson 8: Solving One- Variable Equations</b>	Students will solve one and multi-step equations. Students will also explain the steps to solving an equation as follows from the equality of numbers and construct viable arguments to justify solution methods.	EE.14 A.3 A.4	PRI 1 PRI 2 PRI 3 PRI 6 PRI 8 PRI 9

Lesson Big Idea	Lesson Details	Content Standards	Process Readiness Indicators
<b>Lesson 9: Formative Assessment Lesson: Solving Linear Equations</b>	This lesson unit is intended to help you assess how well students are able to form and solve linear equations involving factorizing and using the distributive law.	EE.6 EE.8	PRI 1 PRI 2 PRI 3 PRI 4 PRI 6 PRI 7 PRI 8 PRI 9 PRI 10
<b>Lesson 10: Restructuring equations</b>	Students will rearrange equations and formulas in order to solve for a desired variable.	A.5	PRI 1 PRI 2 PRI 3 PRI 7
<b>Lesson 11: Inequalities</b>	Students will explore the connection between equality and inequality.	EE.8 A.4	PRI 1 PRI 2 PRI 3 PRI 4 PRI 7

Not for Review Copy  
Distribution

## Expressions, Equations and Inequalities

# Lesson 1 of 11

## The Hook – Sam’s Diner

### Description:

---

This task was adapted from the online article *Dr. Seuss Comes to Math Class* by Carrie DeFrancisco (as published by Math Solutions in Online Newsletter Issue 1, Spring 2001). Centered around the classic Dr. Seuss book *Green Eggs and Ham*, the author helps students explore mathematical content such as representing quantities with variables, simplifying expressions, interpreting expressions and equations, and solving one and multi-step equations by using the menu from Sam’s Diner, Dr. Seuss’s favorite restaurant, to decode orders and determine the total amount of each order. The task can also be extended to include inequalities.

### College- and Career-Readiness Standards Addressed:

---

- EE.1 Write, read, and evaluate expressions in which letters stand for numbers.
  - Identify parts of an expression using mathematical terms (sum, term, product, factor, quotient, coefficient); view one or more parts of an expression as a single entity. *For example, describe the expression  $2(8 + 7)$  as a product of two factors; view  $(8 + 7)$  as both a single entity and a sum of two terms.*
  - Evaluate expressions at specific values of their variables. Include expressions that arise from formulas used in real-world problems. Perform arithmetic operations, including those involving whole number exponents, in the conventional order when there are no parentheses to specify a particular order (Order of Operations). *For example, use the formulas  $V = s^3$  and  $A = 6s^2$  to find the volume and surface area of a cube with sides of length  $s = \frac{1}{2}$ .*
- EE.4 Use variables to represent numbers and write expressions when solving a real-world or mathematical problem; understand that a variable can represent an unknown number, or, depending on the purpose at hand, any number in a specified set.
- EE.6 Understand that rewriting an expression in different forms in a problem context can shed light on the problem and how the quantities in it are related. *For example,  $a + 0.05a = 1.05a$  means that “increase by 5%” is the same as “multiply by 1.05.”*
- EE.7 Solve multi-step real-life and mathematical problems posed with positive and negative rational numbers in any form (whole numbers, fractions, and decimals), using tools strategically. Apply properties of operations to calculate with numbers in any form; convert between forms as appropriate; and assess the reasonableness of answers using mental computation and estimation strategies.
- A.1 Interpret expressions that represent a quantity in terms of its context.
  - Interpret complicated expressions by viewing one or more of their parts as a single entity. For example, interpret  $P(1+r)^n$  as the product of  $P$  and a factor not depending on  $P$ .

- A.2 Choose and produce an equivalent form of an expression to reveal and explain properties of the quantity represented by the expression.
- A.3 Explain each step in solving a simple equation as following from the equality of numbers asserted at the previous step, starting from the assumption that the original equation has a solution. Construct a viable argument to justify a solution method.

### Process Readiness Indicator(s) Emphasized:

- PRI 1: Make sense of problems and persevere in solving through reasoning and exploration.
- PRI 2: Reason abstractly and quantitatively by using multiple forms of representations to make sense of and understand mathematics.
- PRI 3: Describe and justify mathematical understandings by constructing viable arguments, critiquing the reasoning of others and engaging in meaningful mathematical discourse.
- PRI 4: Contextualize mathematical ideas by connecting them to real-world situations. Model with mathematics.
- PRI 6: Attend to precision.
- PRI 7: Look for and make use of patterns and structure.
- PRI 8: Look for and express regularity in repeated reasoning.

Sequence of  
Instruction

Activities Checklist

### Engage

This lesson is a formative lesson and not to be used to teach content necessarily. The questions and practice should be open-ended intentionally so that you as the teacher can gauge student prior knowledge of variables, expressions and equations. You should be listening intently to student discussion and using this information to evaluate students and their progress.

Pose the following question to your students: Think of a situation where a group of people must have a common language. Then, make a list of “terms” that they would need to communicate with each other.

For example: for baseball, you need to know specific terms like pitcher, outfield, bases, strike, batter...

Make the connection that with mathematics we also have a common language in which we use symbols to represent words or numbers. (Vocabulary: expressions, equations, pattern, variables; students should have previous understanding of these terms.)

## Explore

**PRI 1**  
**PRI 2**  
**PRI 6**  
**PRI 7**

Read the book *Green Eggs and Ham* by Dr. Seuss aloud to the class. (Optional)

After reading to the students, explain to them that they will be ordering, eating and working over the next couple of days at one of Dr. Seuss's favorite restaurants, Sam's Diner.

Provide each pair of students a copy of the menu to Sam's Diner. *Teacher note: You may want to create a large size menu on chart paper for the class to see.*

<i>Green Eggs</i> .....	<i>\$2.25</i>
<i>Regular Eggs</i> .....	<i>\$2.00</i>
<i>Ham</i> .....	<i>\$1.50</i>
<i>Bacon</i> .....	<i>\$1.25</i>
<i>Small Drink</i> .....	<i>\$0.75</i>
<i>Large Drink</i> .....	<i>\$1.00</i>
<i>Today's Special</i> .....	<i>\$4.25</i>

After students review the menu, explain to them that time and efficiency are very important in a restaurant, and sometimes waiters and waitresses use their own version of "shorthand" to write down a customer's order. Present the following ticket and have students assist the cook and tell him what has been ordered:

INCLUDED IN THE STUDENT MANUAL

### Task #1: Sam's Diner

**Ticket order #1:** G + H + S

What did the customer order? (Possible answers: Green eggs, ham, small drink)

How do you know?

How much is his order? (Prompt students to use mental math.) (\$4.50)

How did you find the sum mentally?

Did anyone do it a different way?

## Explanation

**PRI 1**  
**PRI 2**  
**PRI 3**  
**PRI 6**  
**PRI 7**

For tickets 2, 3 and 4, put students in groups of 3 to discuss what was ordered and mentally calculate the cost of each bill. Tell them to be sure that each of them agrees and can explain their thinking and strategies to the class.

INCLUDED IN THE STUDENT MANUAL

**Ticket order #2:**  $2G + B = ?$

**Ticket order #3:**  $E + 3H + 2L = ?$

**Ticket order #4:**  $X + G + S = ?$

What was the order for ticket #2? (Possible answer: 2 orders of green eggs, 1 order of bacon)

How much was the bill? (\$5.75)

What did your group come up with for ticket order #3? (Check for different explanations of this ticket.) (Regular eggs, 3 orders of ham, 2 large drinks; \$8.50)

What do you think was ordered on ticket #4? Do you think the order was made by one person? (Check to see if other groups agree or disagree.) (Possible answer: Probably not; if 'X' represents the Today's Special, which includes green eggs and a small drink, it is possible that more than one person placed an order on this ticket.)

What was the total amount of the bill? (\$7.25)

How did you calculate that?

Provide the students with the following large orders that were sent to the kitchen. Have the students discuss with their partners what was ordered and mentally calculate the cost of each bill. Tell them to be sure that each of them agrees and can explain their thinking and strategies to the class.

INCLUDED IN THE STUDENT MANUAL

**Ticket order #5:**  $2(G + H) = ?$

**Ticket order #6:**  $(G + S) + 2H = ?$

**Ticket order #7:**  $X + 3(E + L) = ?$

**Ticket order #8:**  $3(E + B + L) + 2X = ?$

**What did the party order on ticket #5? (Possible answer: 2 orders of green eggs and ham) Is there another way of looking at their order?**

**What is the cost of the order on ticket #5? (\$7.50)**

**What did the last party order (ticket #8)? What is another way of looking at that order? (Possible answer: 3 orders of regular eggs, bacon and a large drink and 2 Specials)**

**How did you calculate the cost of ticket #8? Is there a group that did this another way? (Make sure students explain how they calculated the cost. Look for students who use distributive property vs. students who use order of operations; \$21.25)**

## Practice Individually

- PRI 2** If the students are in pairs, regroup them into groups of three so that students can take turns being the customer, waiter and cashier.
- PRI 4**
- PRI 6** Each customer has to decide what food to order; each waiter is responsible for writing the orders; and each cashier is in charge of calculating the cost.

## Evaluate Understanding

- PRI 4** Pose the following question to the students to discuss in their small groups: Suppose each customer was given \$10 to spend and should spend as much of it as possible without going over. What can you order?
- PRI 6**
- PRI 7**

*Questions for the students once they have had time to consider the question (Whole group discussion. Be sure to call on different groups of students to answer.):*

- Was anyone able to spend exactly \$10? Why or why not?
- What was the largest order you could make without going over \$10?
- How can you represent this situation?

## Closing Activity

- PRI 1** Ask students to explain a situation where they would use expressions in real life.
- PRI 2**

INCLUDED IN THE STUDENT MANUAL

### Task #2: Closing Activity

1. Describe a scenario that could be represented by each of the following expressions:
  - a.  $x - 3$
  - b.  $2x + 3$
  - c.  $5x + 2y$

After students have time to respond, give them the following expressions and ask them to describe a scenario each one could represent. So that students do not focus on Sam's Diner scenarios, provide examples from a different context.

$$x - 3$$

*(Ex. If  $x$  represents points on a test, then the expression represents losing 3 points on the test.)*

$$2x + 1$$

*(Ex. If  $x$  represents the number of songs on your iPhone last month, then the expression tells us that you now have twice as many plus one songs.)*

$$5x + 2y$$

*(Ex. If  $x$  represents number of adult tickets and  $y$  represents the number of student tickets, then the expression represents total cost of adult and student tickets attending the event.)*





## Expressions, Equations and Inequalities

# Lesson 2 of 11

## The Hook – Sam’s Diner

### Description:

---

This task was adapted from the online article *Dr. Seuss Comes to Math Class* by Carrie DeFrancisco (as published by Math Solutions in Online Newsletter Issue 1, Spring 2001). Centered around the classic Dr. Seuss book *Green Eggs and Ham*, the author helps students explore mathematical content such as representing quantities with variables, simplifying expressions, interpreting expressions and equations, and solving one and multi-step equations by using the menu from Sam’s Diner, Dr. Seuss’s favorite restaurant, to decode orders and determine the total amount of each order. The task can also be extended to include inequalities.

### College- and Career-Readiness Standards Addressed:

---

- EE.1 Write, read, and evaluate expressions in which letters stand for numbers.
  - Identify parts of an expression using mathematical terms (sum, term, product, factor, quotient, coefficient); view one or more parts of an expression as a single entity. *For example, describe the expression  $2(8 + 7)$  as a product of two factors; view  $(8 + 7)$  as both a single entity and a sum of two terms.*
  - Evaluate expressions at specific values of their variables. Include expressions that arise from formulas used in real-world problems. Perform arithmetic operations, including those involving whole number exponents, in the conventional order when there are no parentheses to specify a particular order (Order of Operations). *For example, use the formulas  $V = s^3$  and  $A = 6s^2$  to find the volume and surface area of a cube with sides of length  $s = \frac{1}{2}$ .*
- EE.4 Use variables to represent numbers and write expressions when solving a real-world or mathematical problem; understand that a variable can represent an unknown number, or, depending on the purpose at hand, any number in a specified set.
- EE.6 Understand that rewriting an expression in different forms in a problem context can shed light on the problem and how the quantities in it are related. *For example,  $a + 0.05a = 1.05a$  means that “increase by 5%” is the same as “multiply by 1.05.”*
- EE.7 Solve multi-step real-life and mathematical problems posed with positive and negative rational numbers in any form (whole numbers, fractions, and decimals), using tools strategically. Apply properties of operations to calculate with numbers in any form; convert between forms as appropriate; and assess the reasonableness of answers using mental computation and estimation strategies.
- EE.8 Use variables to represent quantities in a real-world or mathematical problem, and construct simple equations and inequalities to solve problems by reasoning about the quantities
- EE.14 Solve linear equations in one variable.

- Give examples of linear equations in one variable with one solution, infinitely many solutions, or no solutions. Show which of these possibilities is the case by successively transforming the given equation into simpler forms, until an equivalent equation of the form  $x = a$ ,  $a = a$ , or  $a = b$  results (where  $a$  and  $b$  are different numbers).
- Solve linear equations with rational number coefficients, including equations whose solutions require expanding expressions using the distributive property and collecting like terms.
- A.1 Interpret expressions that represent a quantity in terms of its context.
  - Interpret complicated expressions by viewing one or more of their parts as a single entity. For example, interpret  $P(1+r)^n$  as the product of  $P$  and a factor not depending on  $P$ .
- A.3 Choose and produce an equivalent form of an expression to reveal and explain properties of the quantity represented by the expression.
- A.4 Solve linear equations and inequalities in one variable, including equations with coefficients

### Process Readiness Indicator(s) Emphasized:

- PRI 2: Reason abstractly and quantitatively by using multiple forms of representations to make sense of and understand mathematics.
- PRI 3: Describe and justify mathematical understandings by constructing viable arguments, critiquing the reasoning of others and engaging in meaningful mathematical discourse.
- PRI 6: Attend to precision.
- PRI 7: Look for and make use of patterns and structure.
- PRI 8: Look for and express regularity in repeated reasoning.

Sequence of  
Instruction

Activities Checklist

### Engage

#### PRI 3

Have students exchange their scenarios from question 2 of Task #2 of Lesson 1 (Independent Practice) with a partner and have them translate each other's work into expressions.

Have some volunteers share their scenarios and expressions with the whole group.

### Explore

#### PRI 1

Refer back to the previous lesson using the same menu from Sam's Diner.

#### PRI 2

Inform the students that they will be helping the cook figure out ticket orders again; however, several of the orders have been smudged because of grease spots and ketchup spills.

#### PRI 3

#### PRI 6

#### PRI 7

Have the students work in pairs or small groups to determine what was ordered using the information that is legible.

INCLUDED IN THE STUDENT MANUAL

### Task #3: Sam's Diner, Part 2

**Ticket #9:**   $(E + L) = \$6.00$

**Ticket #10:**  $X + 3$    $= \$6.50$

**Ticket #11:**   $G + H = \$10.50$

**Ticket #12:**   $+ G + B = \$5.50$

After the students have had an opportunity to work, use the following questions to guide class discussion:

INCLUDED IN THE STUDENT MANUAL

### Task #3: Sam's Diner, Part 2

**How many orders of eggs and a large drink were ordered on ticket #9? How can you tell?** (Possible answer: 2 orders of each)

**On ticket #10, what did the customer order 3 of? How do you know?** (Possible answer: if students assume  $X$  represents the Today's Special, there were 3 orders of small drinks)

**How many orders of green eggs are on ticket #11? Explain.** (Possible answer: 4 orders of green eggs)

**What else was ordered besides green eggs and bacon on ticket #12? How do you know? Is there another possibility for this order? Explain.** (There are several combinations that work here. Students should recognize that their choices should add up to \$2.)

## Explanation

**PRI 7**

Once all of the smudged tickets have been discussed, pose the following question:

**Can anyone explain in his or her own words a method or foolproof way to solve problems like these?**

## Practice Together / in Small Groups / Individually

See "Explore" above.

## Evaluate Understanding

**PRI 1**  
**PRI 8**

Provide students with the following prompt:

Look at the following equation:  $2x + 4 = 24$  Can you use it to describe a real-world situation and solve for the missing information?

## Closing Activity

**PRI 1**  
**PRI 3**

Ask students to write a real-world scenario involving an equation.

Have them trade scenarios with another student and have them translate each other's work into an equation and solve it.

INCLUDED IN THE STUDENT MANUAL

### Task #4: Closing Activity

**Write a real-world scenario that involves an equation.**

---

---

---

---

---

---

---

---

---

---

Not for Review Copy  
Distribution

## Independent Practice:

Ask students to represent the following scenario with an equation.

INCLUDED IN THE STUDENT MANUAL

Jesse and his brother Michael went to Burger Hut to order dinner for the family. They ordered 8 cheeseburgers (\$3 each), 6 Cokes (\$2 each), a strawberry shake (\$2.50) and some fries (\$1.30 each). If their total bill was \$45.00, how many orders of fries did they have?

## Resources/Instructional Materials Needed:

- Pencil and paper
- Mini-white boards (optional)
- Book: *Green Eggs and Ham* by Dr. Seuss (optional)
- PowerPoint or SMART file: Sam's Diner (optional)
- Student Manual Task #3 and Task #4

## Expressions, Equations and Inequalities

# Lesson 3 of 11

## Creating Expressions

*Adapted from the “Algebra Through Visual Patterns I” Lesson 1, by Eugene Maier, Larry Linnen, the Math Learning Center*

### Description:

---

Students will be asked to create expressions (in context) from a verbal description, and explore the relationship between numerical and algebraic expressions. Students will be asked to create equations (in context) from a verbal description. Students will also create and examine equivalent equations, and explore the idea of when a solution exists or does not exist.

### College- and Career-Readiness Standards Addressed:

---

- EE.1 Write, read, and evaluate expressions in which letters stand for numbers.
  - Identify parts of an expression using mathematical terms (sum, term, product, factor, quotient, coefficient); view one or more parts of an expression as a single entity. *For example, describe the expression  $2(8 + 7)$  as a product of two factors; view  $(8 + 7)$  as both a single entity and a sum of two terms.*
  - Evaluate expressions at specific values of their variables. Include expressions that arise from formulas used in real-world problems. Perform arithmetic operations, including those involving whole number exponents, in the conventional order when there are no parentheses to specify a particular order (Order of Operations). *For example, use the formulas  $V = s^3$  and  $A = 6s^2$  to find the volume and surface area of a cube with sides of length  $s = \frac{1}{2}$ .*
- EE.4 Use variables to represent numbers and write expressions when solving a real-world or mathematical problem; understand that a variable can represent an unknown number, or, depending on the purpose at hand, any number in a specified set.
- EE.7 Solve multi-step real-life and mathematical problems posed with positive and negative rational numbers in any form (whole numbers, fractions, and decimals), using tools strategically. Apply properties of operations to calculate with numbers in any form; convert between forms as appropriate; and assess the reasonableness of answers using mental computation and estimation strategies.

### Process Readiness Indicator(s) Emphasized:

---

- PRI 2: Reason abstractly and quantitatively by using multiple forms of representations to make sense of and understand mathematics.
- PRI 3: Describe and justify mathematical understandings by constructing viable arguments, critiquing the reasoning of others and engaging in meaningful mathematical discourse.
- PRI 6: Attend to precision.
- PRI 7: Look for and make use of patterns and structure.
- PRI 8: Look for and express regularity in repeated reasoning.

Sequence of Instruction

Activities Checklist

Engage

PRI 2  
PRI 3  
PRI 6  
PRI 7

For the ticket orders that were taken in Sam’s Diner, the wait staff used abbreviations to record the orders. The abbreviations corresponded to food items and also to prices of food items on the menu. This is an example of the usefulness of expressions and equations. We sometimes have a need to quickly represent something that will change for different instances.

Let’s look at another example of what that could look like using counting tiles:

INCLUDED IN THE STUDENT MANUAL

Task #5: Counting Tiles

If blue boxes represent one positive unit (1), use the patterns below to consider what the 4th figure, 10th figure, 20th figure, 100th figure and eventually the  $n$ th figure would look like. The  $n$ th figure is any figure in the pattern.

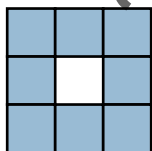

fig 1

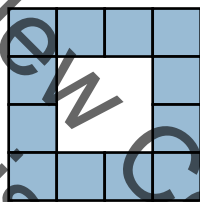

fig 2

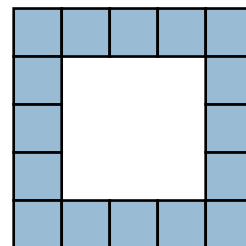

fig 3

Note: As the students are working in pairs, the teacher should listen for conversations about how they could find the number of tiles in the 10th figure. Look for pairs of students that have different ways of looking for the 10th figure. Ask students who quickly get to the 10th figure to find the 20th figure, 100th figure. Workspace for Task #5 is provided in Student Manual on pg. 9-10.

Explore

PRI 8

Now let’s examine the patterns we see. Ask a student to share how they determined the number of tiles in the 10th figure. Ask for someone who might have found a different way of finding the number of tiles in the 10th figure. Try to get students to explore other ways to find the number of tiles and what the figure will look like past the 10th figure. (See teacher notes for Task #5.)

Now let’s expand our thinking. Look at each of the arrangements and the different ways the number of tiles were counted. You may want students to put their data in a chart. You can show that no matter how they counted or grouped the tiles the totals are the same for everyone. Can we expand this to the 20th figure? Can we expand this to the  $n$ th figure? (See teacher notes for Task #5.)

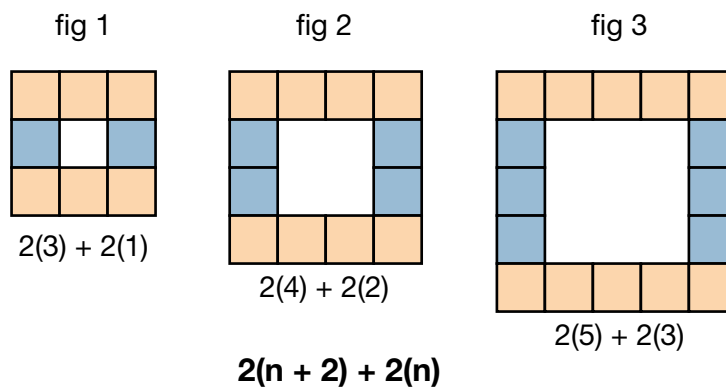
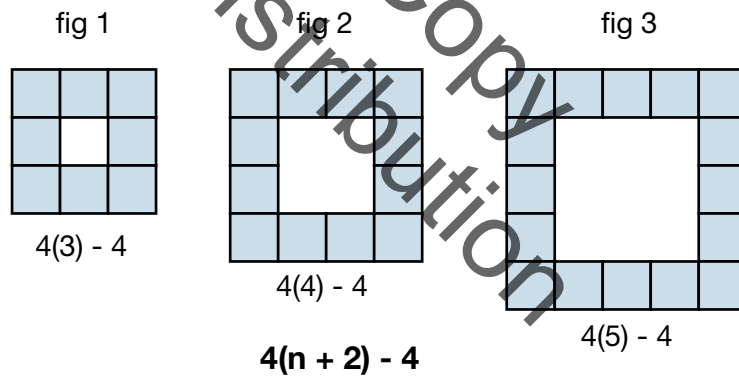
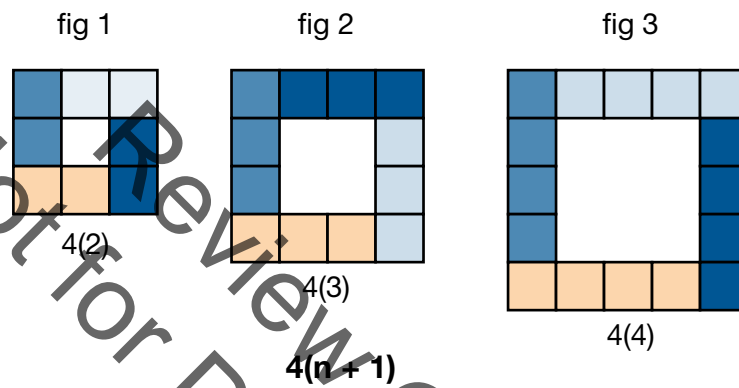
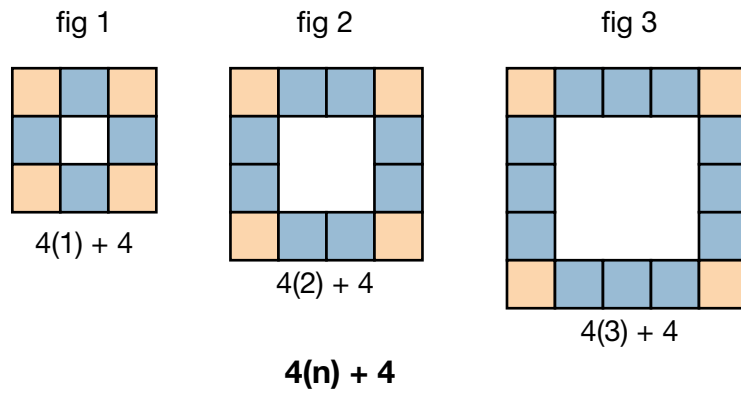

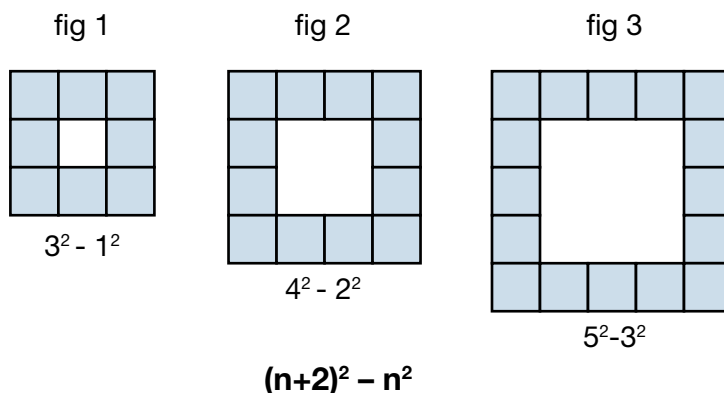

**Teacher notes for Task #5:**

**Possible Explanation #1:** The 4 corners can represent the +4. Then the number of the figure is in ( ) and it occurs 4 times. This gives you the value of the figure to equal the number of tiles used.

**Possible Explanation #2:** Here you can group the sides and multiple by 4. See the color coding.

**Possible Explanation #3:** You can also just choose each side and subtract the repeated corners.

**Possible Explanation #4:** Group the top row and the bottom row. Then group the inside columns. See color coding.

**Possible Explanation #5:** Assuming these are squares and using the area model, area of the whole minus area for the center.

**Explanation**

**PRI 3**  
**PRI 8**

As you have students explain the 10th figure, begin inserting the nth strip in the place of the sides to demonstrate how a variable could be used so they wouldn't have to count all the singles one at a time. As the students discuss their 10th figure, have the class discuss the 20th figure using the reasoning from the 10th figure. After all the ways have been discussed as a whole group for the 20th figure, pose the questions: What if we don't know what figure the tiles create? How can we write our expressions in terms of a variable (the nth figure)?

Have students examine their original idea of how to count the tiles to come up with a way to find the unknown figure. Students should be discussing how each of the figures 1-4 have values that remain the same, and which values change and how do they relate to the figure.

It is important to make it explicit to students that the expressions that they created are equivalent. Also, make it explicit to student that when an expression is set equal to a value or another expression, it is now an equation.



After the  $n$ th figure is created, the number of tiles is either another variable or a number. If it is a number, what numbers could work for the tiles? Does it matter what we set the  $n$ th expression equal to? *Expression must be set equal to a whole number because you cannot have a fractional tile.*

### Practice Together / in Small Groups / Individually

---

**PRI 3**  
**PRI 7**  
**PRI 8**

Have students work in pairs and create a pattern of tiles like in the first activity. Now have them write an expression for their pattern. After they have written an expression, have them write equations for each figure by setting it equal to the number of tiles that they have used. Are the number of tiles equivalent to the number with the term value is substituted in the student's expression? Have students make the next level of their patterns using their equations to determine if it is correct.

Have each pair repeat this at least twice. Make sure they follow through with the expressions and look for a pattern for the total number of tiles. (This is important for students to think about the connection of the expression and the equation. The numbers are not just made up they have meaning.) You may want to have students record their data in charts to see the number pattern in a different way.

### Evaluate Understanding

---

As students are working in the pairs, the teacher needs to visit each team. The teacher should be listening for the correct vocabulary of expression, patterns, figures, equation,  $n$ th term, and variable. The teacher should be observing that the patterns are true patterns that have not been used already in class and that are not so complicated that the students miss the mathematics.

### Closing Activity

---

To extend this activity, have each team member select one of the expressions that they have created and try to write the expression for the  $n$ th term. The students should provide a written explanation as to why they chose that expression to represent their pattern. This will begin the next day's work.

### Independent Practice:

---

Assign teacher-created patterns and have students write an expression for the pattern and provide a written explanation for their expression. This will help students communicate mathematically. (Task #6, Lesson 3)

### Resources/Instructional Materials Needed:

---

You will need the patterns from today's lesson for tomorrow's extension of the lesson to linear equations.

INCLUDED IN THE STUDENT MANUAL

### Task #6: Independent Practice

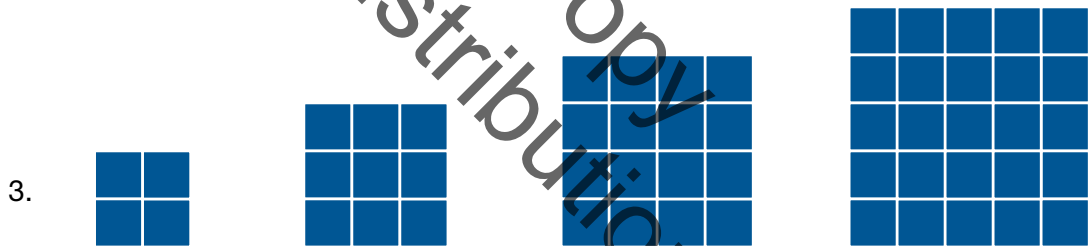
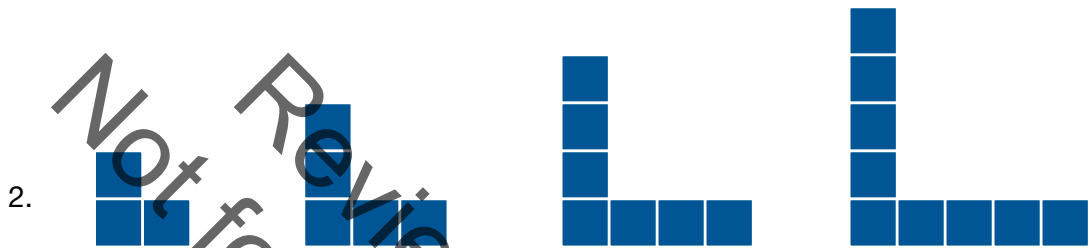

Not for Review Copy  
Not for Distribution

**Task #6: Independent Practice KEY**

1.   $n(2) + 1$  or  $2n + 1$

$1(2) + 1$        $2(2) + 1$        $3(2) + 1$        $4(2) + 1$

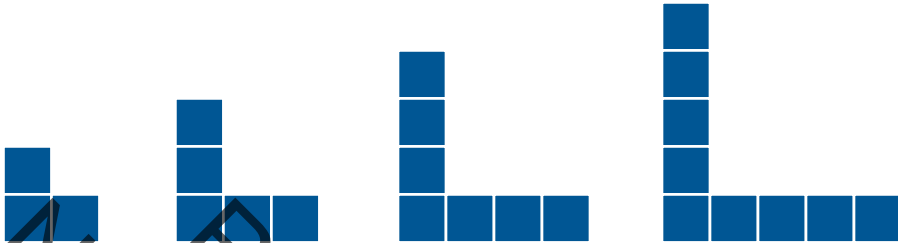
2.   $2(n) + 1$

$1 + 2(1)$        $1 + 2(2)$        $1 + 2(3)$        $1 + 2(4)$

3.   $(n + 1)^2$

$2 \cdot 2$        $3 \cdot 3$        $4 \cdot 4$        $(5 \cdot 5)^2$   
 $2^2$        $3^2$        $4^2$        $5^2$   
 $(1+1)^2$        $(2+1)^2$        $(3+1)^2$        $(4+1)^2$

4.   $n^2$

$1$        $2 \cdot 2$        $3 \cdot 3$        $4 \cdot 4$   
 $2^2$        $3^2$        $4^2$

**Resources/Instructional Materials Needed:**

You will need the patterns from today's lesson for tomorrow's extension of the lesson to linear equations.

Student Manual Task #5 and Task #6

## Expressions, Equations and Inequalities

# Lesson 4 of 11

## Creating Expressions

### Description:

---

Students will be asked to create expressions (in context) from a verbal description, and explore the relationship between numerical and algebraic expressions. Students will be asked to create equations (in context) from a verbal description. Students will also create and examine equivalent equations, and explore the idea of when a solution exists or does not exist

### College- and Career-Readiness Standards Addressed:

---

- EE.1 Write, read, and evaluate expressions in which letters stand for numbers.
  - Identify parts of an expression using mathematical terms (sum, term, product, factor, quotient, coefficient); view one or more parts of an expression as a single entity. *For example, describe the expression  $2(8 + 7)$  as a product of two factors; view  $(8 + 7)$  as both a single entity and a sum of two terms.*
  - Evaluate expressions at specific values of their variables. Include expressions that arise from formulas used in real-world problems. Perform arithmetic operations, including those involving whole number exponents, in the conventional order when there are no parentheses to specify a particular order (Order of Operations). *For example, use the formulas  $V = s^3$  and  $A = 6s^2$  to find the volume and surface area of a cube with sides of length  $s = \frac{1}{2}$ .*
- EE.4 Use variables to represent numbers and write expressions when solving a real-world or mathematical problem; understand that a variable can represent an unknown number, or, depending on the purpose at hand, any number in a specified set.
- EE.7 Solve multi-step real-life and mathematical problems posed with positive and negative rational numbers in any form (whole numbers, fractions, and decimals), using tools strategically. Apply properties of operations to calculate with numbers in any form; convert between forms as appropriate; and assess the reasonableness of answers using mental computation and estimation strategies.

### Process Readiness Indicator(s) Emphasized:

---

- PRI 2: Reason abstractly and quantitatively by using multiple forms of representations to make sense of and understand mathematics.
- PRI 3: Describe and justify mathematical understandings by constructing viable arguments, critiquing the reasoning of others and engaging in meaningful mathematical discourse.
- PRI 6: Attend to precision.
- PRI 7: Look for and make use of patterns and structure.
- PRI 8: Look for and express regularity in repeated reasoning.

Sequence of Instruction

Activities Checklist

### Engage

**PRI 6**

From the previous lesson have students recall the expressions that they created from the example used:  $4(n) + 4$ ,  $4(n+1)$ ,  $4(n+2) - 4$ ,  $2(n+2) + 2(n)$ ,  $(n+2)^2 - n^2$

Have the students recreate the first 4 or 5 figures from the previous lesson with their tiles or on grid paper. Have the students rearrange each figure into a single column bar to form a bar graph. Have the students to create a bar graph for the first 5 figures and label the x and y axis. What does the x and y axis represent?

### Explore

After the students have the bar graph completed, discuss the data that is shown on the graph. Discuss the equivalent values of the tiles for each figure they began with to the data on the bar graph. Now have the students convert the bar graph to data points on a grid. Have them graph and label the order pairs for each figure.  $\{(1, 8), (2, 12), (3, 16), (4, 20), (5, 24)\}$  Discuss the pattern they see.

### Explanation

**PRI 7**

**PRI 8**

The x -value is the number of the figure and the y-value is the number of tiles used to create the figure. The space between the points is equal. To move from one point to the next you must move one square to the right and four squares up. Each point increases the same amount on the grid. The points only represent integers because you cannot have a half tile.

*Teachers note: If a student automatically connects the dots have the conversation about what that line means. Discuss the fact that you cannot have a  $\frac{1}{2}$  tile in this example and introduce the difference between discrete data and non-discrete data briefly.*

### Practice Together / in Small Groups / Individually

**PRI 3**

**PRI 6**

**PRI 7**

**PRI 8**

Pass out Task #7: Practicing Patterns and have students pair up and work the following examples:

INCLUDED IN THE STUDENT MANUAL

**Task #7: Practicing Patterns**

Practice patterns for creating expressions:

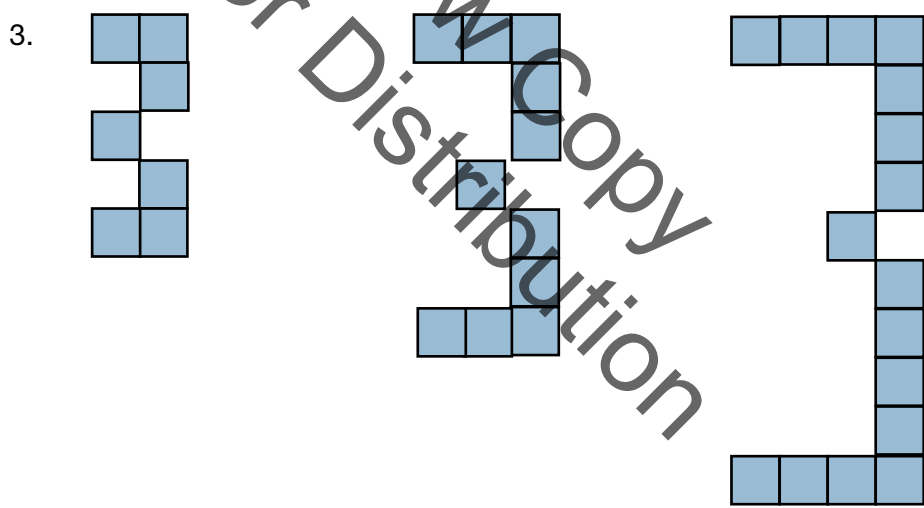
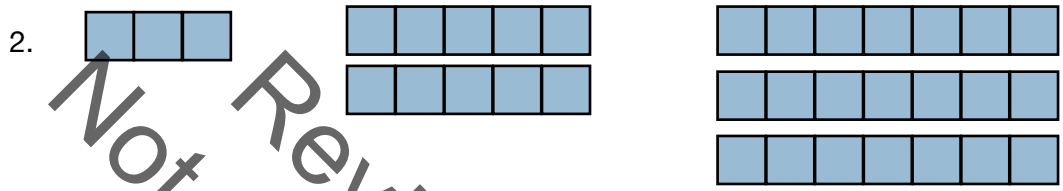
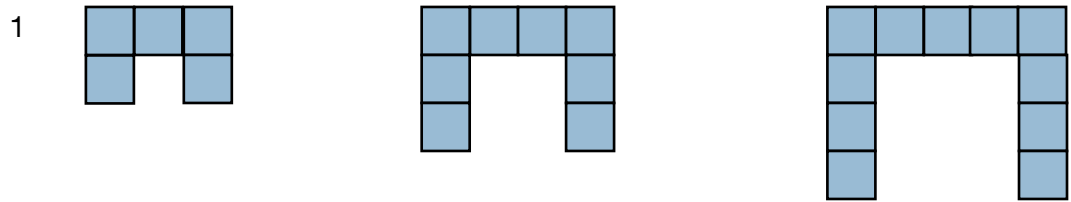

a. Describe in words only what the 20th figure will look like so that someone could draw or make it if they had the grid paper or tiles.

---

---

---

---

---

b. How many tiles would you need to build the 20th figure? Draw a sketch of the 20th figure.

c. Write an expression for the  $n$ th figure and explain why you chose that expression? Write a different expression for the  $n$ th figure.

d. Using  $\frac{1}{4}$  inch grid paper, graph the number of tiles used for the first several arrangements.

As the students are working, listen for conversations about different types of expressions. Look for the scale that students are using on their graphs. As students finish the examples, have a group discussion to examine different ways to write an expression for the figures. Be sure to have the students explain why they created their expressions.

**Possible solutions for examples 1-3:**

1.  $(n + 3) + 2n$ ,  $2(n+1) + n$
2.  $n(2n + 1)$ ,  $2n^2 + n$
3.  $4n + 3$ ,  $2(n + 1 + n) + 1$  or  $2(n) + 2(n) + 3$

### Evaluate Understanding

Use example number 3 to check for understanding. Have students work individually to answer the questions for this figure. This can be an exit slip or even a homework problem.

### Closing Activity

Pose the following questions to begin some discussion: What if we could have  $\frac{1}{2}$  tiles or fractional tiles? How would the data change? How would the graphs change? What if we had positive and negative tiles in the same figure? What would change if we added some negative tiles in the pattern?

### Independent Practice:

---

Have students try to create a pattern with the tiles different from any of the patterns they created in the previous lesson or in today's lesson. Then have the students answer the same questions as the example questions.

### Resources/Instructional Materials Needed:

---

25 Algebra tiles or square counters  
1/4 inch grid paper, at least 2 sheets per student  
Student Manual Task #7

Review Copy  
Not for Distribution



## Expressions, Equations and Inequalities

# Lesson 5 of 11

## Identifying Equivalent Expressions

### Description:

---

Students will be asked to create and interpret equivalent expressions. They will examine how symbolic manipulation of expressions affects values in real circumstances. Students will also explore a real-life problem that includes some basic geometric concepts along with expression manipulation.

### College- and Career-Readiness Standards Addressed:

---

- EE.2 Apply the properties of operations to generate equivalent expressions. For example, apply the distributive property to the expression  $3(2 + x)$  to produce the equivalent expression  $6 + 3x$ ; apply the distributive property to the expression  $24x + 18y$  to produce the equivalent expression  $6(4x + 3y)$ ; apply properties of operations to  $y + y + y$  to produce the equivalent expression  $3y$ .
- EE.3 Identify when two expressions are equivalent (i.e., when the two expressions name the same number regardless of which value is substituted into them). For example, the expressions  $y + y + y$  and  $3y$  are equivalent because they name the same number regardless of which number  $y$  stands for.
- EE.6 Understand that rewriting an expression in different forms in a problem context can shed light on the problem and how the quantities in it are related. For example,  $a + 0.05a = 1.05a$  means that “increase by 5%” is the same as “multiply by 1.05.”
- EE.7 Solve multi-step real-life and mathematical problems posed with positive and negative rational numbers in any form (whole numbers, fractions, and decimals), using tools strategically. Apply properties of operations to calculate with numbers in any form; convert between forms as appropriate; and assess the reasonableness of answers using mental computation and estimation strategies.
- EE.9 Know and apply the properties of integer exponents to generate equivalent numerical expressions. For example,  $3^2 \times 3^{-5} = 3^{-3} = (1/3)^3 = 1/27$ .
- A.1 Interpret expressions that represent a quantity in terms of its context.
  - Interpret complicated expressions by viewing one or more of their parts as a single entity. For example, interpret  $P(1+r)^n$  as the product of  $P$  and a factor not depending on  $P$ .
- A.2 Choose and produce an equivalent form of an expression to reveal and explain properties of the quantity represented by the expression.

### Process Readiness Indicator(s) Emphasized:

---

- PRI 2: Reason abstractly and quantitatively by using multiple forms of representations to make sense of and understand mathematics.

- PRI 3: Describe and justify mathematical understandings by constructing viable arguments, critiquing the reasoning of others and engaging in meaningful mathematical discourse.
- PRI 4: Contextualize mathematical ideas by connecting them to real-world situations. Model with mathematics.
- PRI 9: Demonstrate flexible use of strategies and methods while reflecting on which procedures seem to work best for specific types of problems.

Sequence of Instruction

Activities Checklist

Engage

PRI 4

Ask students:

- What careers require employees to write and evaluate expressions?
- Is it possible for different employees or people to problem solve in different ways but arrive at the same answer?
- Does the problem solving method matter?

Video of property appraiser in action

ex: [https://www.youtube.com/watch?v=\\_EpZWsPTWHs](https://www.youtube.com/watch?v=_EpZWsPTWHs) (For maximum engagement, start video at 1:34 and end at 3:45)

Explore

INCLUDED IN THE STUDENT MANUAL

Task #8: Sam's Diner

This is a floor plan for Sam's Diner. The city needs to know the total square footage to calculate the maximum capacity for fire and safety regulations. What is the total area, in square feet, of Sam's Diner?

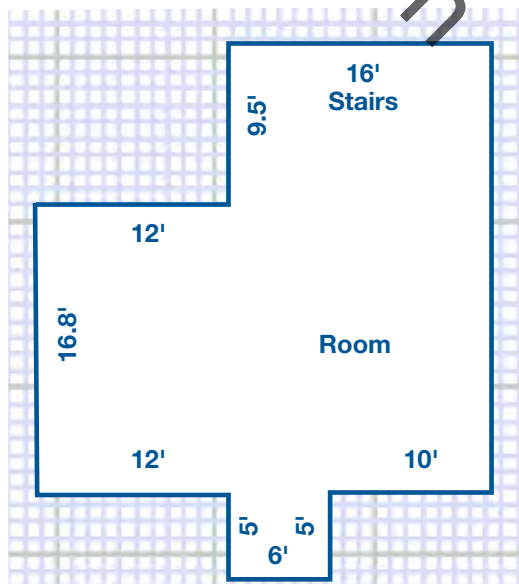

Remind students that area is the number of squares that cover a space (polygon) and to find the area of a rectangle you multiply the base by the height. Students work in pairs to determine the total area using composite figures. Ask students to explain their methods and highlights different approaches to solve the same problem. Equivalent numerical expressions are formed by students with different approaches.

Students share their methods and solutions in groups. Select two correct but different student approaches to display.

*Teacher Note: Total Area is 652.4 sq. ft.*

## Explanation

Demonstrate and review how to simplify expressions. Have students apply mathematical properties to write and evaluate equivalent expressions with a surface area application.

- Highlights: Distributive Property, Combining like Terms, factoring with GCF and substitution.

Students should take guided notes.

ex 1) Combining Like Terms

$$3 + x - 8 + 5x + 4x^2$$

Note: Use Algebra tiles to model like terms.

ex 2) Distributive Property

$$3(x + 4)$$

Continue to model with Algebra tiles “three groups of  $(x + 4)$ ,” Draw an area model by tracing around the algebra tiles to reinforce the same concept.

ex 3) Factoring with GCF

$$24x + 16$$

Use Algebra tiles and pose the following question: **What is the largest number of equal sized groups that the algebra tiles can be separated into?** *eight*

Model the groups, then rearrange the tiles into a rectangle that has dimensions 8 by  $(3x + 2)$ . Relate factoring the binomial to finding the length and width of the area model.

ex 4) Evaluate equivalence by substituting the values  $x = 0$  and  $x = 1$  into the expressions and simplifying.

**Determine if the following expressions are equivalent:**

$$-2(4x - 3) \quad -8x + 6$$

*Teacher Note: Yes, they are equivalent.*

## Practice Together / in Small Groups / Individually

### PRI 3

In pairs, the students work on writing an expression to represent the area of each figure from Task #9: Algebraic Expressions Representing Areas. Each student receives a copy. The teacher circulates and asks the students to justify their expression based on the models. After about 8-10 mins. One student from the pair remains seated while the other rotates to compare expressions with another group. While working with a new partner, the students need to determine if their expressions are equivalent. If so, they should be added to their document, if not they need to determine which is correct. One more rotation may be necessary. Students return to their original group and discuss their findings.

INCLUDED IN THE STUDENT MANUAL

**Task 9: (Practice Together) Algebraic Expressions**

Write an algebraic expression to represent the area of each figure. You will compare your group's strategy with another group. Prepare to explain and justify your expressions.

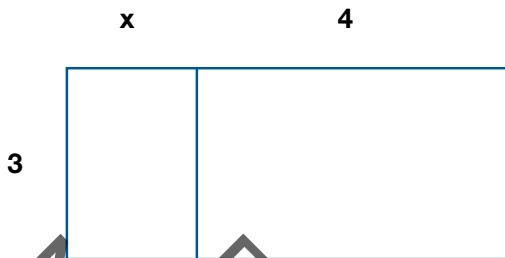

Figure 1

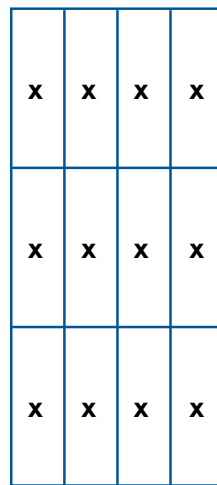

Figure 2

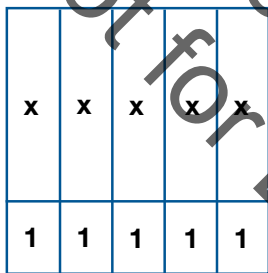

Figure 3



Figure 4

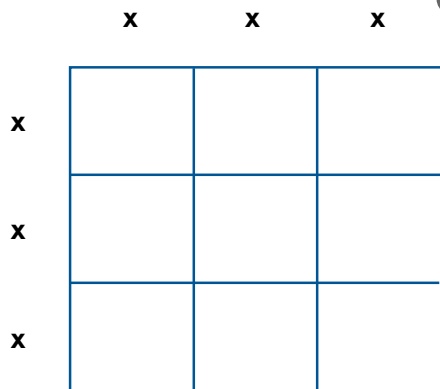

Figure 5

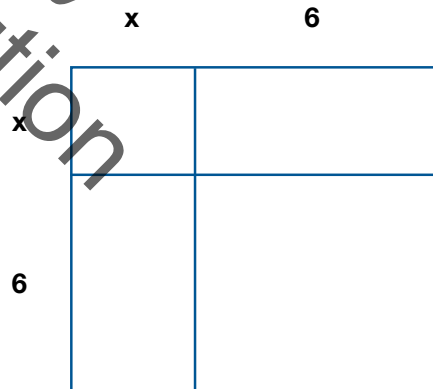

Figure 6

**Answer Key for Task #9**

1.  $3(x+4) = 3x+12$
2.  $4(3x) = 12x$
3.  $5(x+1) = 5x+5$
4.  $3(5x) = 15x$
5.  $(3x)(3x) = 9x^2$
6.  $(x+6)^2 = x^2 + 12x+ 36$

At this point the teacher should hold a whole group discussion. Students should be asked to share their expressions and how they checked if another group had an equivalent expression. The teacher should reiterate the distributive property, like terms, factoring and substitution through this discussion.

Next, the students work with a partner Task #10: Sorting Algebraic Expressions based on equivalence. They must justify their matches (ie. area models or calculations).

Early finishers are asked to write additional equivalent expressions in each quadrant.

Finally, the teacher asks students to share their matches and explain their thinking on the matching portion of the practice activity.

INCLUDED IN THE STUDENT MANUAL

### Task #10: Sorting Algebraic Expressions

Sort the following expressions into the quadrants below based on equivalence. Justify your matches with area models or calculations.

- $4x^2$
- $(4x)(4x)$
- $4(x+4)$
- $4x+4$
- $16x^2$
- $4x+16$
- $x^2+x^2+x^2+x^2$
- $(x+1)+(x+1)+(x+1)+(x+1)$

#### Equivalent Expressions

#### Answer Key

- $4x^2 = x^2 + x^2 + x^2 + x^2$
- $(4x)(4x) = 16x^2$
- $4(x+4) = 4x + 16$
- $4x+4 = (x+1) + (x+1) + (x+1) + (x+1)$

## Evaluate Understanding

**PRI 9**

Students answer the following question:

What strategies can be used to determine if expressions are equivalent?

## Closing Activity

**PRI 3**

INCLUDED IN THE STUDENT MANUAL

### Task #11: Closing Activity

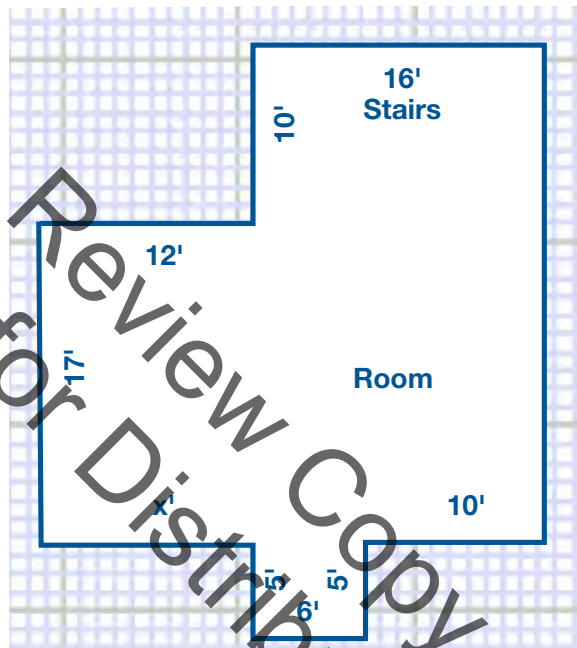

Two students formed the following expressions to represent the area of floor plan above. How did they form the expressions? Are they both correct? *Teacher Note: the expressions are not equivalent.* How do you know?

$$160 + 17(x + 16) + 30 \qquad 206 + 17x$$

Students debate & defend in groups of 3.

Whole group discussion:

- How can we check to see if these expressions are equivalent? *Possible answer: If a particular value for a variable is given or in question, you can substitute it into each expression and simplify using order of operations to see if both expressions yield the same value. Another method to determine if two expressions are always equivalent is setting them equal to each other and solving. If you end up with a false statement ie.  $12 = 4$ , then they are never equal to each other. If you end up with a true statement ie.  $0 = 0$ , then the expressions are always equivalent.*
- What math properties can we apply to simplify each expression? *Possible answer: distributive property and substitution*
- Where is the error? How can we fix it? *Possible answer: distribute correctly and follow orders of operation*

**Independent Practice:**

---

Khan Academy

<https://www.khanacademy.org/math/algebra-basics/core-algebra-expressions/core-algebra-manipulating-expressions/e/equivalent-forms-of-expressions-1>

**Resources/Instructional Materials Needed:**

---

Printout with partner practice problems

PowerPoint or PDF with Teacher examples

SMART board or Document camera

Algebra tiles

Student Manual Task #8, Task #9, Task #10, Task #11

**Notes:**

Not for Review Copy  
Distribution

## Expressions, Equations and Inequalities

# Lesson 6 of 11

## Interpreting Algebraic Expressions (Concept Development FAL)

### Description:

---

This lesson is intended to help you assess how well students are able to translate between words, symbols, tables, and area representations of algebraic expressions. It will help you to identify and support students who have difficulty:

- Recognizing the order of algebraic operations.
- Recognizing equivalent expressions.
- Understanding the distributive laws of multiplication and division over addition (expansion of parentheses).

### College- and Career-Readiness Standards Addressed:

---

- A.1 Interpret expressions that represent a quantity in terms of its context.
  - b. Interpret complicated expressions by viewing one or more of their parts as a single entity. For example, interpret  $P(1+r)^n$  as the product of  $P$  and a factor not depending on  $P$ .
- A.2 Choose and produce an equivalent form of an expression to reveal and explain properties of the quantity represented by the expression.

### Resources/Instructional Materials Needed:

---

Formative Assessment Lesson: <http://map.mathshell.org/lessons.php?unit=9225&collection=8>

### Notes:

---

This task requires teacher to cut four different sets of cards (enough for each group). Some activities will stretch to the learner beyond the basic standards.

### Process Readiness Indicator(s) Emphasized:

---

PRI 1: Make sense of problems and persevere in solving through reasoning and exploration.

PRI 2: Reason abstractly and quantitatively by using multiple forms of representations to make sense of and understand mathematics.

PRI 4: Contextualize mathematical ideas by connecting them to real-world situations. Model with mathematics.

PRI 5: Use appropriate tools strategically to support thinking and problem solving.



PRI 6: Attend to precision.

PRI 7: Look for and make use of patterns and structure.

PRI 8: Look for and express regularity in repeated reasoning.

PRI 9: Demonstrate flexible use of strategies and methods while reflecting on which procedures seem to work best for specific types of problems.

PRI 10: Reflect on mistakes and misconceptions to improve mathematical understanding.

The following *Formative Assessment Lesson* is a classroom-ready lesson included to help teachers assess and improve students' understanding of mathematical concepts and skills and their ability to use the mathematical process readiness indicators critical for college readiness.

Research has shown that formative assessment, as embodied in the following lesson, is a powerful way to improve student learning and performance. This approach first allows students to demonstrate their prior understandings and abilities in employing the mathematical processes, and then resolve their own difficulties and misconceptions through structured discussion. This results in more secure long-term learning, reducing the need for re-teaching that otherwise takes so much classroom time.

Many often ask, why don't students just remember the procedures they have been taught and practiced? The fact is, that approach works fine in the short term but, as every teacher knows, if procedural knowledge is not underpinned by conceptual understanding, students will quickly forget "how to do it."

Read more about the *Formative Assessment Lesson* rationale, structure, and philosophy using the *Brief Guide for Teachers and Administrators* that can be found at <http://map.mathshell.org/materials/index.php>.

---

## CONCEPT DEVELOPMENT

---

Mathematics Assessment Project  
**CLASSROOM CHALLENGES**  
A Formative Assessment Lesson

# Interpreting Algebraic Expressions

Not for Review Copy  
Not for Distribution

Mathematics Assessment Resource Service  
University of Nottingham & UC Berkeley

For more details, visit: <http://map.mathshell.org>  
© 2015 MARS, Shell Center, University of Nottingham  
May be reproduced, unmodified, for non-commercial purposes under the Creative Commons license  
detailed at <http://creativecommons.org/licenses/by-nc-nd/3.0/> - all other rights reserved

## BEFORE THE LESSON

### Assessment task: *Interpreting Expressions* (10 minutes)

Have students do this task in class or for homework a day or more before the formative assessment lesson. This will give you an opportunity to assess the work and to find out the kinds of difficulties students have with it. You should then be able to target your help more effectively in the subsequent lesson.

Give each student a copy of *Interpreting Expressions*.

*I want you to spend ten minutes working individually on this task.*

*Don't worry too much if you can't understand or do everything. There will be a lesson [tomorrow] with a similar task that will help you improve.*

It is important that, as far as possible, students are allowed to answer the questions without assistance.

If students are struggling to get started, ask them questions that help them to understand what is required, but do not do the task for them.

**Interpreting Expressions**

1. Write algebraic expressions for each of the following:

a. Multiply  $n$  by 5 then add 4. \_\_\_\_\_

b. Add 4 to  $n$  then multiply by 5. \_\_\_\_\_

c. Add 4 to  $n$  then divide by 5. \_\_\_\_\_

d. Multiply  $n$  by  $n$  then multiply by 3. \_\_\_\_\_

e. Multiply  $n$  by 3 then square the result. \_\_\_\_\_

2. The equations below were created by students who were asked to write equivalent expressions on either side of the equals sign.  
 Imagine you are a teacher. Your job is to decide whether their work is right or wrong. If you see an equation that is false, then:

a. Cross out the expression on the right and replace it with an expression that is equivalent to the one on the left.

b. Explain what is wrong, using words or diagrams.

$$2(n + 3) = 2n + 3$$

$$\frac{10n - 5}{5} = 2n - 1$$

$$(5n)^2 = 5n^2$$

$$(n + 3)^2 = n^2 + 3^2 = n^2 + 9$$

### Assessing students' responses

Collect students' responses to the task. Make some notes about what their work reveals about their current levels of understanding. The purpose of doing this is to forewarn you of the difficulties students will experience during the lesson itself, so that you may prepare carefully.

We suggest that you do not score students' papers. The research shows that this will be counterproductive, as it will encourage students to compare their scores and distract their attention from what they can do to improve their mathematics.

Instead, help students to make further progress by summarizing their difficulties as a list of questions. Some suggestions for these are given in the *Common issues* table on the next page. We suggest that you make a list of your own questions, based on your students' work, using the ideas on the following page. We recommend you either:

- write one or two questions on each student's work, or
- give each student a printed version of your list of questions and highlight the questions relevant to each student.

If you do not have time to do this, you could select a few questions that will be of help to the majority of students and write these on the board when you return the work to the students in the follow-up lesson.

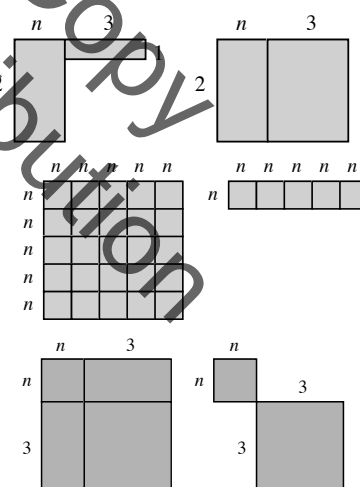
Common issues:	Suggested questions and prompts:
<p><b>Writes expressions left to right, showing little understanding of the order of operations implied by the symbolic representation</b></p> <p>For example: The student writes:</p> <p>Q1a. <math>n \times 5 + 4</math> (not incorrect).                      Q1b. <math>4 + n \times 5</math>.                      Q1c. <math>4 + n \div 5</math>.                      Q1d. <math>n \times n \times 3</math>.</p>	<ul style="list-style-type: none"> <li>Can you write answers to the following?  <math>4 + 1 \times 5</math>  <math>4 + 2 \times 5</math>  <math>4 + 3 \times 5</math></li> <li>Check your answers with your (scientific) calculator. How is your calculator working these out?</li> <li>So what does <math>4 + n \times 5</math> mean? Is this the same as Q1b?</li> </ul>
<p><b>Does not construct parentheses correctly or expands them incorrectly</b></p> <p>For example: The student writes:</p> <p>Q1b. <math>4 + n \times 5</math> instead of <math>5(n + 4)</math>.                      Q1c. <math>4 + n \div 5</math> instead of <math>\frac{4+n}{5}</math>.</p> <p>Or: The student counts:</p> <p>Q2. <math>2(n+3) = 2n+3</math> as correct.                      Q2. <math>(5n)^2 = 5n^2</math> as correct.                      Q2. <math>(n+3)^2 = n^2 + 3^2</math> as correct.</p>	<ul style="list-style-type: none"> <li>Which one of the following is the odd one out:  <i>Think of a number, add 3, and then multiply your answer by 2.</i>  <i>Think of a number, multiply it by 2, and then add 3.</i>  <i>Think of a number, multiply it by 2, and then add 6.</i>                      Why?</li> </ul>
<p><b>Identifies errors but does not give explanations</b></p> <p>For example: The student corrects the first, third and fourth statements, but no explanation or diagram is used to explain why they are incorrect (Q2).</p>	<ul style="list-style-type: none"> <li>How would you write expressions for these areas?</li> </ul>  <ul style="list-style-type: none"> <li>Can you do this in different ways?</li> </ul>

## SUGGESTED LESSON OUTLINE

### Interactive whole-class introduction (10 minutes)

Give each student a mini-whiteboard, pen, and eraser and hold a short question and answer session. If students show any incorrect answers, write the correct answer on the board and discuss any problems.

*On your mini-whiteboards, show me an algebraic expression that means:*

*Multiply  $n$  by 4 and then add 3 to your answer.*  $4n + 3$

*Add 3 to  $n$  and then multiply your answer by 4.*  $4(3 + n)$

*Add 5 to  $n$  and then divide your answer by 3.*  $\frac{n + 5}{3}$

*Multiply  $n$  by  $n$  and then multiply your answer by 5.*  $5n^2$

*Multiply  $n$  by 5 and then square your answer.*  $(5n)^2$

### Collaborative activity 1: matching expressions and words (20 minutes)

The first activity is designed to help students interpret symbols and realize that the way the symbols are written defines the order of operations.

Organize students into groups of two or three.

Display Slide P-1 of the projector resource:

**Matching Expressions and Words**

$4(n + 2)$	Multiply $n$ by two, then add four.
$2(n + 4)$	Add four to $n$ , then multiply by two.
$4n + 2$	Add two to $n$ , then multiply by four.

Note that one of the algebraic expressions does not have a match in words. This is deliberate! It is to help you explain the task to students.

Model the activity briefly for students, using the examples on the projector resource:

*I am going to give each group two sets of cards, one with expressions written in algebra and the other with words.*

*Take turns to choose an expression and find the words that match it. [ $4(n + 2)$  matches 'Add 2 to  $n$  then multiply by 4';  $2(n + 4)$  matches 'Add 4 to  $n$  then multiply by 2'.]*

*When you are working in groups, you should place these cards side by side on the table and explain how you know that they match.*

*If you cannot find a matching card, then you should write your own using the blank cards provided. [ $4n + 2$  does not match any of the word cards shown on Slide P-1. The word card 'Multiply  $n$  by two, then add four' does not match any of the expressions.]*

Give each small group of students a cut-up copy of *Card Set A: Expressions* and *Card Set B: Words*:

Card Set A: Expressions		Card Set B: Words	
E1	$\frac{n+6}{2}$	E2	$3n^2$
E3	$2n+12$	E4	$2n+6$
E5	$2(n+3)$	E6	$\frac{n}{2}+6$
E7	$(3n)^2$	E8	$(n+6)^2$
E9	$n^2+12n+36$	E10	$3+\frac{n}{2}$
E11	$n^2+6$	E12	$n^2+6^2$
E13		E14	
W1	Multiply $n$ by two, then add six.	W2	Multiply $n$ by three, then square the answer.
W3	Add six to $n$ then multiply by two.	W4	Add six to $n$ then divide by two.
W5	Add three to $n$ then multiply by two.	W6	Add six to $n$ then square the answer.
W7	Multiply $n$ by two then add twelve.	W8	Divide $n$ by two then add six.
W9	Square $n$ , then add six	W10	Square $n$ , then multiply by nine
W11		W12	
W13		W14	

Support students in making matches and explaining their decisions. As they do this, encourage them to speak the algebraic expressions out loud. Students may not be used to ‘talking algebra’ and may not know how to say what is written, or may do so in ways that create ambiguities.

For example, the following conversation between a teacher and student is fairly typical:

*Teacher:* Tell me in words what this one says. [Teacher writes:  $3+\frac{n}{2}$ .]

*Student:* Three add  $n$  divided by two.

*Teacher:* How would you read this one then? [Teacher writes:  $\frac{(3+n)}{2}$ .]

*Student:* Three add  $n$  divided by two. Oh, but in the second one you are dividing it all by two.

*Teacher:* So can you try reading the first one again, so it sounds different from the second one?

*Student:* Three add ... [pause] ...  $n$  divided by two [said quickly]. Or  $n$  divided by two, then add three.

Students will need to make word cards to match E10:  $3+\frac{n}{2}$  and E12:  $n^2+6^2$ .

They will also need to make expression cards to match W3: Add 6 to  $n$ , then multiply by 2 and W10: Square  $n$ , then multiply by 9.

Some students may notice that some expressions are equivalent, for example  $2(n+3)$  and  $2n+6$ . You do not need to comment on this now as when *Card Set C: Tables* is given out, students will be able to notice this for themselves.

**Collaborative activity 2: matching expressions, words, and tables (20 minutes)**

Give each small group of students a cut-up copy of *Card Set C: Tables*:

<b>Card Set C: Tables</b>																					
<p><b>T1</b></p> <table border="1" style="width: 100%; border-collapse: collapse; text-align: center;"> <tr><td><math>n</math></td><td>1</td><td>2</td><td>3</td><td>4</td></tr> <tr><td>Ans</td><td>14</td><td>16</td><td>18</td><td>20</td></tr> </table>	$n$	1	2	3	4	Ans	14	16	18	20	<p><b>T2</b></p> <table border="1" style="width: 100%; border-collapse: collapse; text-align: center;"> <tr><td><math>n</math></td><td>1</td><td>2</td><td>3</td><td>4</td></tr> <tr><td>Ans</td><td></td><td></td><td>81</td><td>144</td></tr> </table>	$n$	1	2	3	4	Ans			81	144
$n$	1	2	3	4																	
Ans	14	16	18	20																	
$n$	1	2	3	4																	
Ans			81	144																	
<p><b>T3</b></p> <table border="1" style="width: 100%; border-collapse: collapse; text-align: center;"> <tr><td><math>n</math></td><td>1</td><td>2</td><td>3</td><td>4</td></tr> <tr><td>Ans</td><td></td><td>10</td><td>15</td><td>22</td></tr> </table>	$n$	1	2	3	4	Ans		10	15	22	<p><b>T4</b></p> <table border="1" style="width: 100%; border-collapse: collapse; text-align: center;"> <tr><td><math>n</math></td><td>1</td><td>2</td><td>3</td><td>4</td></tr> <tr><td>Ans</td><td>3</td><td></td><td>27</td><td>48</td></tr> </table>	$n$	1	2	3	4	Ans	3		27	48
$n$	1	2	3	4																	
Ans		10	15	22																	
$n$	1	2	3	4																	
Ans	3		27	48																	
<p><b>T5</b></p> <table border="1" style="width: 100%; border-collapse: collapse; text-align: center;"> <tr><td><math>n</math></td><td>1</td><td>2</td><td>3</td><td>4</td></tr> <tr><td>Ans</td><td></td><td></td><td>81</td><td>100</td></tr> </table>	$n$	1	2	3	4	Ans			81	100	<p><b>T6</b></p> <table border="1" style="width: 100%; border-collapse: collapse; text-align: center;"> <tr><td><math>n</math></td><td>1</td><td>2</td><td>3</td><td>4</td></tr> <tr><td>Ans</td><td></td><td>10</td><td>12</td><td>14</td></tr> </table>	$n$	1	2	3	4	Ans		10	12	14
$n$	1	2	3	4																	
Ans			81	100																	
$n$	1	2	3	4																	
Ans		10	12	14																	
<p><b>T7</b></p> <table border="1" style="width: 100%; border-collapse: collapse; text-align: center;"> <tr><td><math>n</math></td><td>1</td><td>2</td><td>3</td><td>4</td></tr> <tr><td>Ans</td><td></td><td>4</td><td></td><td>5</td></tr> </table>	$n$	1	2	3	4	Ans		4		5	<p><b>T8</b></p> <table border="1" style="width: 100%; border-collapse: collapse; text-align: center;"> <tr><td><math>n</math></td><td>1</td><td>2</td><td>3</td><td>4</td></tr> <tr><td>Ans</td><td>6.5</td><td>7</td><td>7.5</td><td>8</td></tr> </table>	$n$	1	2	3	4	Ans	6.5	7	7.5	8
$n$	1	2	3	4																	
Ans		4		5																	
$n$	1	2	3	4																	
Ans	6.5	7	7.5	8																	

*Card Set C: Tables* will make students substitute numbers into the expressions and will alert them to the fact that different expressions are equivalent.

Ask students to match these new cards to the two card sets they have been working on. Some tables have numbers missing and students will need to write these in.

Encourage students to use strategies for matching. There are shortcuts that will help to minimize the work. For example, some may notice that:

*Since  $2(n + 3)$  is an even number, we can just look at tables with even numbers in them.*

*Since  $(3n)^2$  is a square number, we can look for tables with only square numbers in them.*

Students will notice that there are fewer tables than expressions. This is because some tables match more than one expression. Allow students time to discover this for themselves. As they do so, encourage them to test that they match for all  $n$ . This is the beginning of a generalization.

*Do  $2(n + 3)$  and  $2n + 6$  always give the same answer when  $n = 1, 2, 3, 4, 5$ ?*

*What about when  $n = 3246$ , or when  $n = -23$ , or when  $n = 0.245$ ?*

*Check on your calculator.*

*Can you explain how you can be sure?*

This last question is an important one and will be followed up in the next part of the lesson.

**Extending the lesson over two days**

It is important not to rush the learning. At about this point, some lessons run out of time. If this happens, ask pupils to stack their cards in order, so that matching cards are grouped together and fasten them with a paper clip. Ask students to write their names on an envelope and store the matched cards in it. These envelopes can then be reissued at the start of next lesson.

**Collaborative activity 3: matching expressions, words, tables, and areas (20 minutes)**

Give each small group of students a cut-up copy of the *Card Set D: Areas*, a large sheet of paper, a felt-tipped pen, and a glue stick.

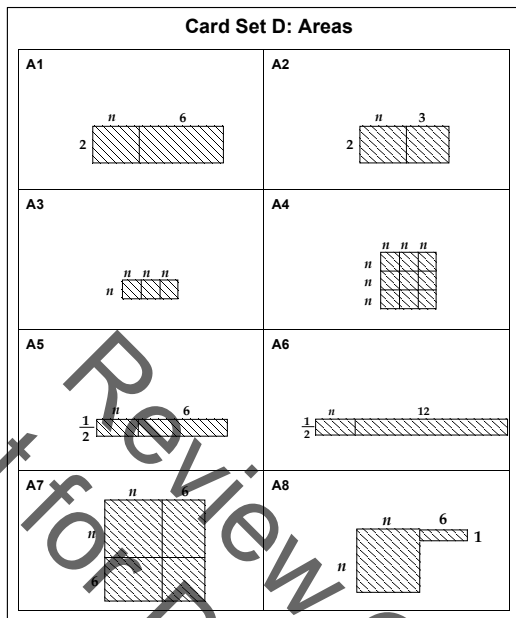

The *Card Set D: Areas* will help students to understand why the different expressions match the same tables of numbers.

*Each of these cards shows an area.*

*I want you to match these area cards to the cards already on the table.*

*When you reach agreement, paste down your final arrangement of cards onto the large sheet of paper, creating a poster.*

*Next to each group of cards write down why the areas show that different expressions are equivalent.*

The posters students produce will need to be displayed in the final whole-class discussion. They may look something like this:





As students match the cards, encourage them to explain and write down **why** particular pairs of cards go together.

*Why does this area correspond to  $n^2 + 12n + 36$ ?*

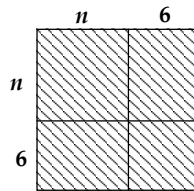

*Show me where  $n^2$  is in this diagram. Where is  $12n$ ? Where is the  $36$  part of the diagram?*

*Now show me why it also shows  $(n + 6)^2$ .*

*Where is the  $n + 6$ ?*

Ask students to identify groups of expressions that are equivalent and explain their reasoning. For example, E1 is equivalent to E10, E8 is equivalent to E9, and E4 is equivalent to E5.

**Whole-class discussion (20 minutes)**

Hold a whole-class interactive discussion to review what has been learned over this lesson.

Ask each group of students to justify, using their poster, why two expressions are equivalent.

Then use mini-whiteboards and questioning to begin to generalize the learning:

*Draw me an area that shows this expression:*  $3(x + 4)$

*Write me a different expression that gives the same area.*

*Draw me an area that shows this expression:*  $(4y)^2$

*Write me a different expression that gives the same area.*

*Draw me an area that shows this expression:*  $(z + 5)^2$

*Write me a different expression that gives the same area.*

*Draw me an area that shows this expression:*  $\frac{w + 6}{2}$

*Write me a different expression that gives the same area.*

**Follow-up lesson: improving individual solutions to the assessment task (10 minutes)**

Return students' work on the assessment task *Interpreting Expressions*, along with a fresh copy of the task sheet. If you have not added questions to individual pieces of work, write your list of questions on the board. Students should select from this list only those questions they think are appropriate to their own work.

*Read through the solution you wrote [yesterday] and the questions (on the board/written on your script).*

*Answer the questions and then thinking about what you learned this lesson, write a new solution to see if you can improve your work.*

Some teachers give this as a homework task.

## SOLUTIONS

### Assessment task: Interpreting Expressions

- 1a.  $5n + 4$ .  
 1b.  $5(n + 4)$ .  
 1c.  $\frac{n + 4}{5}$ .  
 1d.  $3n^2$ .  
 1e.  $(3n)^2$ .
2.  $2(n + 3) \neq 2n + 3$ ,  $2(n + 3) = 2n + 6$ .

$$\frac{10n - 5}{5} = 2n - 1 \text{ is correct.}$$

$$(5n)^2 \neq 5n^2, (5n)^2 = 25n^2.$$

$$(n + 3)^2 \neq n^2 + 3^2, (n + 3)^2 = n^2 + 6n + 9 \text{ (} n^2 + 3^2 \text{ does however equal } n^2 + 9 \text{)}.$$

### Lesson task

This table is for convenience only: it is helpful **not** to refer to cards by these letters in class, but rather to the content of the cards.

Expressions	Words	Tables	Areas
E1 E10	W4 W13 (Blank) Divide $n$ by 2 then add 3	T7	A5
E2	W11 (Blank) Square $n$ then multiply by 3	T4	A3
E3 E13 (Blank) $2(n + 6)$	W3 W7	T1	A1
E4 E5	W1 W5	T6	A2
E6	W8	T8	A6
E7 E14 (Blank) $9n^2$	W2 W10	T2	A4
E8 E9	W6 W14 (Blank) Square $n$ , add 12 multiplied by $n$ , add 36	T5	A7
E11	W9	T3	A8
E12	W12 (Blank) Square $n$ then add 6 squared		

## Interpreting Expressions

1. Write algebraic expressions for each of the following:

- a. Multiply  $n$  by 5 then add 4. \_\_\_\_\_
- b. Add 4 to  $n$  then multiply by 5. \_\_\_\_\_
- c. Add 4 to  $n$  then divide by 5. \_\_\_\_\_
- d. Multiply  $n$  by  $n$  then multiply by 3. \_\_\_\_\_
- e. Multiply  $n$  by 3 then square the result. \_\_\_\_\_

2. The equations below were created by students who were asked to write equivalent expressions on either side of the equals sign.

Imagine you are a teacher. Your job is to decide whether their work is right or wrong. If you see an equation that is false, then:

- a. Cross out the expression on the right and replace it with an expression that is equivalent to the one on the left.
- b. Explain what is wrong, using words or diagrams.

$$2(n + 3) = 2n + 3$$

$$\frac{10n - 5}{5} = 2n - 1$$

$$(5n)^2 = 5n^2$$

$$(n + 3)^2 = n^2 + 3^2 = n^2 + 9$$

### Card Set A: Expressions

E1 $\frac{n+6}{2}$	E2 $3n^2$
E3 $2n+12$	E4 $2n+6$
E5 $2(n+3)$	E6 $\frac{n}{2}+6$
E7 $(3n)^2$	E8 $(n+6)^2$
E9 $n^2+12n+36$	E10 $3+\frac{n}{2}$
E11 $n^2+6$	E12 $n^2+6^2$
E13	E14

### Card Set B: Words

<b>W1</b> Multiply $n$ by two, then add six.	<b>W2</b> Multiply $n$ by three, then square the answer.
<b>W3</b> Add six to $n$ then multiply by two.	<b>W4</b> Add six to $n$ then divide by two.
<b>W5</b> Add three to $n$ then multiply by two.	<b>W6</b> Add six to $n$ then square the answer.
<b>W7</b> Multiply $n$ by two then add twelve.	<b>W8</b> Divide $n$ by two then add six.
<b>W9</b> Square $n$ , then add six	<b>W10</b> Square $n$ , then multiply by nine
<b>W11</b>	<b>W12</b>
<b>W13</b>	<b>W14</b>

### Card Set C: Tables

<b>T1</b> <table border="1"><tr><td><i>n</i></td><td>1</td><td>2</td><td>3</td><td>4</td></tr><tr><td><i>Ans</i></td><td>14</td><td>16</td><td>18</td><td>20</td></tr></table>	<i>n</i>	1	2	3	4	<i>Ans</i>	14	16	18	20	<b>T2</b> <table border="1"><tr><td><i>n</i></td><td>1</td><td>2</td><td>3</td><td>4</td></tr><tr><td><i>Ans</i></td><td></td><td></td><td>81</td><td>144</td></tr></table>	<i>n</i>	1	2	3	4	<i>Ans</i>			81	144
<i>n</i>	1	2	3	4																	
<i>Ans</i>	14	16	18	20																	
<i>n</i>	1	2	3	4																	
<i>Ans</i>			81	144																	
<b>T3</b> <table border="1"><tr><td><i>n</i></td><td>1</td><td>2</td><td>3</td><td>4</td></tr><tr><td><i>Ans</i></td><td></td><td>10</td><td>15</td><td>22</td></tr></table>	<i>n</i>	1	2	3	4	<i>Ans</i>		10	15	22	<b>T4</b> <table border="1"><tr><td><i>n</i></td><td>1</td><td>2</td><td>3</td><td>4</td></tr><tr><td><i>Ans</i></td><td>3</td><td></td><td>27</td><td>48</td></tr></table>	<i>n</i>	1	2	3	4	<i>Ans</i>	3		27	48
<i>n</i>	1	2	3	4																	
<i>Ans</i>		10	15	22																	
<i>n</i>	1	2	3	4																	
<i>Ans</i>	3		27	48																	
<b>T5</b> <table border="1"><tr><td><i>n</i></td><td>1</td><td>2</td><td>3</td><td>4</td></tr><tr><td><i>Ans</i></td><td></td><td></td><td>81</td><td>100</td></tr></table>	<i>n</i>	1	2	3	4	<i>Ans</i>			81	100	<b>T6</b> <table border="1"><tr><td><i>n</i></td><td>1</td><td>2</td><td>3</td><td>4</td></tr><tr><td><i>Ans</i></td><td></td><td>10</td><td>12</td><td>14</td></tr></table>	<i>n</i>	1	2	3	4	<i>Ans</i>		10	12	14
<i>n</i>	1	2	3	4																	
<i>Ans</i>			81	100																	
<i>n</i>	1	2	3	4																	
<i>Ans</i>		10	12	14																	
<b>T7</b> <table border="1"><tr><td><i>n</i></td><td>1</td><td>2</td><td>3</td><td>4</td></tr><tr><td><i>Ans</i></td><td></td><td>4</td><td></td><td>5</td></tr></table>	<i>n</i>	1	2	3	4	<i>Ans</i>		4		5	<b>T8</b> <table border="1"><tr><td><i>n</i></td><td>1</td><td>2</td><td>3</td><td>4</td></tr><tr><td><i>Ans</i></td><td>6.5</td><td>7</td><td>7.5</td><td>8</td></tr></table>	<i>n</i>	1	2	3	4	<i>Ans</i>	6.5	7	7.5	8
<i>n</i>	1	2	3	4																	
<i>Ans</i>		4		5																	
<i>n</i>	1	2	3	4																	
<i>Ans</i>	6.5	7	7.5	8																	

### Card Set D: Areas

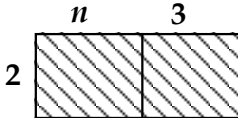
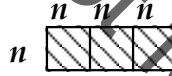
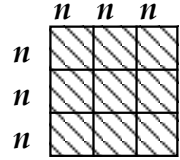
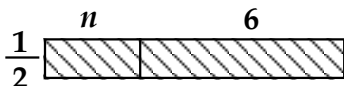
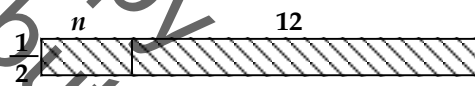
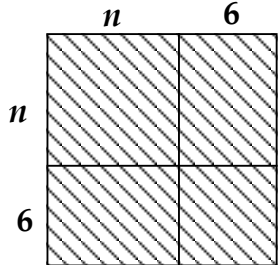
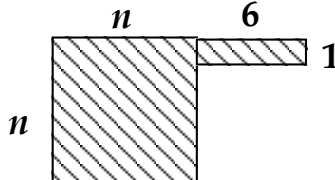
<p><b>A1</b></p> 	<p><b>A2</b></p> 
<p><b>A3</b></p> 	<p><b>A4</b></p> 
<p><b>A5</b></p> 	<p><b>A6</b></p> 
<p><b>A7</b></p> 	<p><b>A8</b></p> 

# Matching Expressions and Words

$$4(n + 2)$$

Multiply  $n$  by two, then add four.

$$2(n + 4)$$

Add four to  $n$ , then multiply by two.

$$4n + 2$$

Add two to  $n$ , then multiply by four.



## Mathematics Assessment Project **Classroom Challenges**

These materials were designed and developed by the  
Shell Center Team at the Center for Research in Mathematical Education  
University of Nottingham, England:

**Malcolm Swan,**  
**Nichola Clarke, Clare Dawson, Sheila Evans, Colin Foster, and Marie Joubert**  
with  
**Hugh Burkhardt, Rita Crust, Andy Noyes, and Daniel Pead**

We are grateful to the many teachers and students, in the UK and the US,  
who took part in the classroom trials that played a critical role in developing these materials

The classroom observation teams in the US were led by  
**David Foster, Mary Bouck, and Diane Schaefer**

This project was conceived and directed for  
The Mathematics Assessment Resource Service (MARS) by  
**Alan Schoenfeld** at the University of California, Berkeley, and  
**Hugh Burkhardt, Daniel Pead, and Malcolm Swan** at the University of Nottingham

Thanks also to Mat Crosier, Anne Floyde, Michael Galan, Judith Mills, Nick Orchard, and Alvaro Villanueva who contributed to the design and production of these materials

This development would not have been possible without the support of  
**Bill & Melinda Gates Foundation**

We are particularly grateful to  
**Carina Wong, Melissa Chabran, and Jamie McKee**

The full collection of Mathematics Assessment Project materials is available from

<http://map.mathshell.org>

© 2015 MARS, Shell Center, University of Nottingham  
This material may be reproduced and distributed, without modification, for non-commercial purposes,  
under the Creative Commons License detailed at <http://creativecommons.org/licenses/by-nc-nd/3.0/>  
All other rights reserved.

Please contact [map.info@mathshell.org](mailto:map.info@mathshell.org) if this license does not meet your needs.

## Expressions, Equations and Inequalities

# Lesson 7 of 11

## Creating Equations

### Description:

---

Students will be asked to create equations (in context) from a verbal description. Students will also create and examine equivalent equations, and explore the idea of when a solution exists or does not exist. Students will represent and solve real-world problems with expressions and equations.

### College- and Career-Readiness Standards Addressed:

---

- EE.8 Use variables to represent quantities in a real-world or mathematical problem, and construct simple equations and inequalities to solve problems by reasoning about the quantities.
  - Solve word problems leading to equations of the form  $px + q = r$  and  $p(x + q) = r$ , where  $p$ ,  $q$ , and  $r$  are specific rational numbers. Solve equations of these forms fluently. Compare an algebraic solution to an arithmetic solution, identifying the sequence of the operations used in each approach. For example, the perimeter of a rectangle is 54 cm. Its length is 6 cm. What is its width?
- EE.14 Solve linear equations in one variable.
  - Give examples of linear equations in one variable with one solution, infinitely many solutions, or no solutions. Show which of these possibilities is the case by successively transforming the given equation into simpler forms, until an equivalent equation of the form  $x = a$ ,  $a = a$ , or  $a = b$  results (where  $a$  and  $b$  are different numbers).
  - Solve linear equations with rational number coefficients, including equations whose solutions require expanding expressions using the distributive property and collecting like terms.
- A.4 Solve linear equations and inequalities in one variable, including equations with coefficients

### Process Readiness Indicator(s) Emphasized:

---

PRI 1: Make sense of problems and persevere in solving through reasoning and exploration.

PRI 2: Reason abstractly and quantitatively by using multiple forms of representations to make sense of and understand mathematics.

PRI 3: Describe and justify mathematical understandings by constructing viable arguments, critiquing the reasoning of others and engaging in meaningful mathematical discourse.

PRI 6: Attend to precision.

Sequence of Instruction

Activities Checklist

Engage

From the entry event lesson “Sam’s Diner,” of the ticket orders that were taken, the waitress used abbreviations (variables) to take the orders and then substituted the cost (money) for the variables to determine the price of the ticket and in some cases, discover what the customer ordered.

Have students look back at the expressions they created in the entry event lesson, and pose the following questions: Could you set the expression equal to any number? Why or why not? Have students discuss this idea. Have them explain what number they would set their expression equal to and how it changes the scenario.

Explore

Green Eggs .....	\$2.25
Regular Eggs .....	\$2.00
Ham .....	\$1.50
Bacon .....	\$1.25
Small Drink .....	\$0.75
Large Drink .....	\$1.00
Today's Special .....	\$4.25

**Ticket order #2:**  $X + G + S = ?$

**Ticket order #3:**  $2G + B = ?$

**Ticket order #4:**  $E + 3H + 2L = ?$

The above ticket orders cannot have a random cost assigned to them. For instance, we cannot just say that Ticket #2 is \$8.00 or \$10.

What are the rules that we must follow to get the correct amount for the orders? *Have to use the set menu prices, and those values determine correct amount for the order.*

**Let's look at another scenario:**

Beth received \$50 for babysitting her little cousin. She goes shopping with her friends and wants to get a new phone cover that is \$25. She then wants to download some music to her phone. About how many songs can Beth download if they cost \$1.29 each?

How is this scenario different from taking orders scenario Sam's Diner?

INCLUDED IN THE STUDENT MANUAL

### Task #12: Equation Scenarios

#### Scenario #1

Beth received \$50 for babysitting her little cousin. She goes shopping with her friends and wants to get a new phone case that costs \$25. She then wants to download some music to her phone. About how many songs can Beth download if they cost \$1.29 each?

a. How is this scenario different from taking orders scenario?

---

---

---

b. Write an equation to represent the scenario.

c. Can she purchase 19.4 songs? How many can she purchase?

---

---

---

### Explanation

**PRI 1**  
**PRI 2**  
**PRI 6**

Teacher says to students: In the taking orders scenario, the cost of each item and how many of each item is known. The total cost of the meal is the unknown. In the shopping scenario the amount of money that can be spent is known and the cost of only one item. The cost of the music is known but the number of songs she can download is not. This should change how one would think about the problem.

Have the students' brainstorm all the information they know about the problem. Make a list and organize the information on the board as they brain storm.

Have each of the students now write an equation to represent the scenario.  $50 = 25 + 1.29M$  or  $50 - 25 = 1.29M$

Have students explain how they determined their equations.

Discuss how to solve the equation. At this point, students are not encouraged to solve algebraically, but by using tables or graphs. ( $\approx 19.4$ )

After the answer is determined, ask students: Can she purchase 19.4 songs? How many can she purchase? *Only 19 songs can be purchased if they are \$1.29 each. She would have \$0.49 left.*

INCLUDED IN THE STUDENT MANUAL

**Task #12: Equation Scenarios contd.**

**Scenario #2**

Beth wants a new cell phone. The phone costs \$240 dollars. Beth can clean the house for her parents and get paid \$5.00 an hour. It takes Beth 6 hours per week to clean the house. How many weeks does Beth need to clean the house to afford her new phone?

a. Write and explain an equation to represent the scenario above.

---

---

---

---

---

b. Solve the equation. Show all your work and be able to explain what you did to solve the equation.

---

---

c. What if we did not know how much Beth wanted to spend on the phone?

---

---

d. How different would the problem be if the total was not known?

---

---

e. What would the new equation look like?

---

---

f. Would a table of values or a graph help us solve this new scenario? Which would be best and why?

---

---

---

---

---

Not for Review Copy Distribution

What if we did not know how much Beth wanted to spend on the phone? How different would the problem be if the total was not known? What would the new equation look like? Would a table of values or a graph help us solve this new scenario? Which would be best and why? *(if we did not know the total then the problem would need another variable in place of the total. The new equation could look like  $P = 30W$ . We now have two variables in the equation. A table of values can help us see how much Beth makes each week. A linear graph will show how fast she can make the money and if she works partial hours.*

Number of weeks	Equation	Total \$\$ earned
1	$30(1)$	\$30
2	$30(2)$	\$60
3	$30(3)$	\$90
6	$30(6)$	\$180
10	$30(10)$	\$300

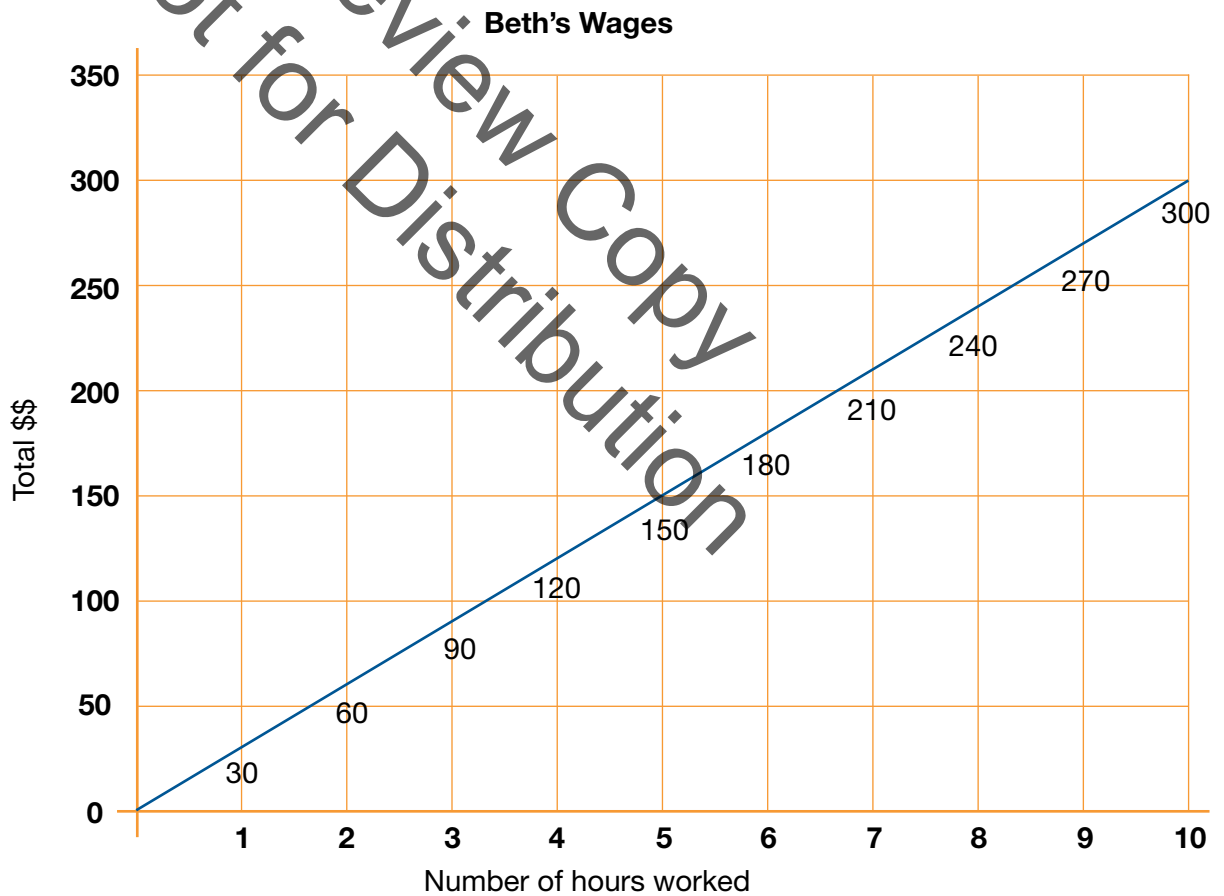

More examples can be found at: <http://www.math-only-math.com/word-problems-on-linear-equations.html>

## Practice Together / in Small Groups / Individually

---

### PRI 1

After the teacher has gone over several examples have the students work together in pairs to solve a few problems. As the students are working walk around and monitor progress. If students are grasping the concept you might want to assign them some more complex problems.

### PRI 2

*Teacher Note: None of these should be solved algebraically. All should be solved using a graph or table of values. If a student is able to solve the equations algebraically, he should be able to justify the solution using a graph or table of values.*

Additional practice problems may be found at: [http://www.math-aids.com/Algebra/Algebra\\_1/Word\\_Problems/](http://www.math-aids.com/Algebra/Algebra_1/Word_Problems/)

## Evaluate Understanding

---

Using a practice sheet from the website above, select 3 problems or create 3 similar problems for students to do individually that were not assigned in the small group section. Only assign these problems after students have had sufficient time to practice several problems and ask questions. Make sure you have spot checked each student's work in small group before you assign these problems.

As you spot check student work and it appears they have a good understanding assign them individual problem to do and turn into you to check. Assign each student in the pairs a different problem so you get more individual responses. Have the student explain the reasoning behind the equation they wrote and how they solved that equation.

## Closing Activity

---

Have the student write their own scenario and write an equation for the scenario as homework. Then the next day choose someone's scenario for the whole class to work. The person's you choose becomes a checker to help you check the classes work.

## Independent Practice:

---

Additional two step word problems for independent practice can be found at the following url: [http://www.mathx.net/students/MATHX.NET-Two-step\\_equations-word\\_problems-integers.pdf](http://www.mathx.net/students/MATHX.NET-Two-step_equations-word_problems-integers.pdf)

## Resources/Instructional Materials Needed:

---

Student Manual Task #12

## Expressions, Equations and Inequalities

# Lesson 8 of 11

## Solving One-variable Equations

### Description:

---

Students will solve one and multi-step equations. Students will also explain the steps to solving an equation as follows from the equality of numbers and construct viable arguments to justify solution methods.

### College- and Career-Readiness Standards Addressed:

---

- EE.14 Solve linear equations in one variable.
  - Give examples of linear equations in one variable with one solution, infinitely many solutions, or no solutions. Show which of these possibilities is the case by successively transforming the given equation into simpler forms, until an equivalent equation of the form  $x = a$ ,  $a = a$ , or  $a = b$  results (where  $a$  and  $b$  are different numbers).
  - Solve linear equations with rational number coefficients, including equations whose solutions require expanding expressions using the distributive property and collecting like terms.
- A.3 Explain each step in solving a simple equation as following from the equality of numbers asserted at the previous step, starting from the assumption that the original equation has a solution. Construct a viable argument to justify a solution method.
- A.4 Solve linear equations and inequalities in one variable, including equations with coefficients

### Process Readiness Indicator(s) Emphasized:

---

PRI 1: Make sense of problems and persevere in solving through reasoning and exploration.

PRI 2: Reason abstractly and quantitatively by using multiple forms of representations to make sense of and understand mathematics.

PRI 3: Describe and justify mathematical understandings by constructing viable arguments, critiquing the reasoning of others and engaging in meaningful mathematical discourse.

PRI 6: Attend to precision.

PRI 8: Look for and express regularity in repeated reasoning.

PRI 9: Demonstrate flexible use of strategies and methods while reflecting on which procedures seem to work best for specific types of problems.



Sequence of  
Instruction

Activities Checklist

## Engage

Select one (or two) student-created problems from the previous lesson and have the class work them. Use the student-writers as the problem experts.

Present the students with a scale with objects on both sides (example below). Pose the following questions:

- What do you know about the shapes?
- If one or more shapes were removed from either side, what do you think would happen?
- Which shape do you think weighs the most? The least?
- How does this balanced scale relate to equations and the idea of “equality?”

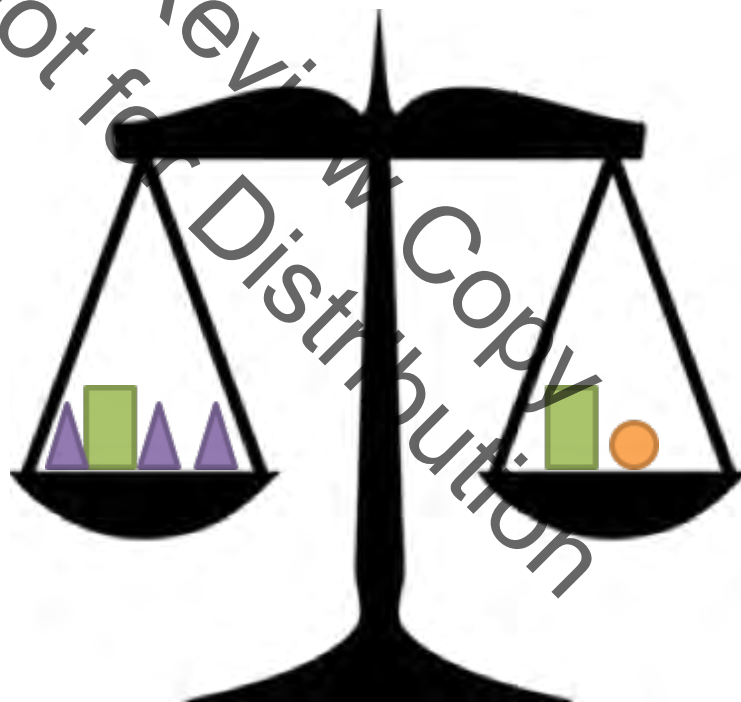

## Explore/Explanation

Begin the lesson with the Learnzillion Core Lesson [video](https://learnzillion.com/lesson_plans/4991-use-a-bar-model-to-write-and-solve-equations) entitled “Use a bar model to write and solve equations.” Be sure to pause and discuss steps and key points in the video and allow students to ask questions. The video can be found at: [https://learnzillion.com/lesson\\_plans/4991-use-a-bar-model-to-write-and-solve-equations](https://learnzillion.com/lesson_plans/4991-use-a-bar-model-to-write-and-solve-equations).

\*\*There is also a downloadable PowerPoint presentation at <http://www.learnzillion.com> for this lesson that includes the core lesson, the guided practice problem, and extension activities.

We can show with the following bar diagram:

<b>x</b>	<b>x</b>	<b>x</b>	<b>5</b>
<b>38</b>			

Consider the following questions to guide a whole group discussion of the model:

- What would this equation look like using the scale model?
- How does the bar diagram relate to the balanced scale?
- Based on the diagram, is  $3x$  more or less than 38?
- How much less is it? How do you know?
- How could you explain that using the bar diagram?
- What steps would you need to follow to solve for  $x$ ?

### Practice Together / in Small Groups / Individually

**PRI 2**  
**PRI 3**  
**PRI 9**

Provide students with the following equations. Have them work together to solve for the unknown variable using a bar model or any other method, explaining each step as they go:

INCLUDED IN THE STUDENT MANUAL

#### Task #13: Equations

Solve the following equations using any method:

a.  $2x + 2 = 10$

b.  $\frac{1}{2}(m + 4) = -4$

(Solutions: a.  $x = 4$     b.  $m = -12$ )

### Evaluate Understanding

**PRI 8**

The Learnzillion Guided Practice [video](#) can be used as another example. Again, it is important to pause and discuss key steps and points in the video and allow students to ask questions. This video can be found at: <https://learnzillion.com/resources/52524>

## Closing Activity

INCLUDED IN THE STUDENT MANUAL

### Task #13: Equations contd.

To keep the equation balanced, what steps do you need to take?

$$3(2n + 1) - 4n = -1$$

*Possible solution:*

*Distribute 3, Combine like terms, subtract 3 from both sides, and divide both sides by 2*

INCLUDED IN THE STUDENT MANUAL

David went to Lenox Mall and purchased 3 shirts, all the same price, as well as a hat for \$16. If he spent \$47.50 at the mall, set up an equation and a bar diagram model that could be used to determine the cost of each shirt.

**Solve the equation for the cost of each shirt, and explain each step used to determine the solution.**

*Solution:*

$x$  = the cost of each shirt

$$x \quad x \quad x \quad 16$$

47.50

$$3x + 16 = 47.50; x = \$10.50$$

## Independent Practice:

### Resources/Instructional Materials Needed:

Dry erase boards

Learnzillion videos (core lesson and guided practice)

Student Manual Task #13

## Expressions, Equations and Inequalities

# Lesson 9 of 11

## Solving Linear Equations (Concept Development FAL)

### Description:

---

This lesson unit is intended to help you assess how well students are able to:

- Form and solve linear equations involving factorizing and using the distributive law.

### College- and Career-Readiness Standards Addressed:

---

- EE.6 Understand that rewriting an expression in different forms in a problem context can shed light on the problem and how the quantities in it are related. For example,  $a + 0.05a = 1.05a$  means that “increase by 5%” is the same as “multiply by 1.05.”
- EE.8 Use variables to represent quantities in a real-world or mathematical problem, and construct simple equations and inequalities to solve problems by reasoning about the quantities.

### Process Readiness Indicator(s) Emphasized:

---

PRI 1: Make sense of problems and persevere in solving through reasoning and exploration.

PRI 2: Reason abstractly and quantitatively by using multiple forms of representations to make sense of and understand mathematics.

PRI 3: Describe and justify mathematical understandings by constructing viable arguments, critiquing the reasoning of others and engaging in meaningful mathematical discourse.

PRI 4: Contextualize mathematical ideas by connecting them to real-world situations. Model with mathematics.

PRI 6: Attend to precision.

PRI 7: Look for and make use of patterns and structure.

PRI 8: Look for and express regularity in repeated reasoning.

PRI 9: Demonstrate flexible use of strategies and methods while reflecting on which procedures seem to work best for specific types of problems.

PRI 10: Reflect on mistakes and misconceptions to improve mathematical understanding.

## Resources/Instructional Materials Needed:

---

Formative Assessment Lesson: <http://map.mathshell.org/lessons.zphp?unit=7220&collection=8>

The following *Formative Assessment Lesson* is a classroom-ready lesson included to help teachers assess and improve students' understanding of mathematical concepts and skills and their ability to use the mathematical process readiness indicators critical for college readiness.

Research has shown that formative assessment, as embodied in the following lesson, is a powerful way to improve student learning and performance. This approach first allows students to demonstrate their prior understandings and abilities in employing the mathematical processes, and then resolve their own difficulties and misconceptions through structured discussion. This results in more secure long-term learning, reducing the need for re-teaching that otherwise takes so much classroom time.

Many often ask, why don't students just remember the procedures they have been taught and practiced? The fact is, that approach works fine in the short term but, as every teacher knows, if procedural knowledge is not underpinned by conceptual understanding, students will quickly forget "how to do it."

Read more about the *Formative Assessment Lesson* rationale, structure, and philosophy using the *Brief Guide for Teachers and Administrators* that can be found at <http://map.mathshell.org/materials/index.php>.

Not for Review Copy  
Distribution

---

## CONCEPT DEVELOPMENT

---

Mathematics Assessment Project  
**CLASSROOM CHALLENGES**  
A Formative Assessment Lesson

# Solving Linear Equations

Not for Review Copy  
Not for Distribution

Mathematics Assessment Resource Service  
University of Nottingham & UC Berkeley

For more details, visit: <http://map.mathshell.org>  
© 2015 MARS, Shell Center, University of Nottingham  
May be reproduced, unmodified, for non-commercial purposes under the Creative Commons license  
detailed at <http://creativecommons.org/licenses/by-nc-nd/3.0/> - all other rights reserved

## BEFORE THE LESSON

### Assessment task: *Express Yourself* (15 minutes)

Have the students do this task, in class or for homework, a day or more before the formative assessment lesson. This will give you an opportunity to assess the work and identify students who have misconceptions or need other forms of help. You should then be able to target your help more effectively in the subsequent lesson.

Give each student a copy of *Express Yourself*.

Introduce the task briefly and help the class to understand what they are being asked to do:

*Spend 15 minutes working individually, answering these questions.*

*Show all your work on the sheet.*

*Make sure you explain your answers really clearly.*

It is important that, as far as possible, students answer the questions without assistance.

Students should not worry too much if they cannot understand or do everything because you will teach a lesson using a similar task, which should help them. Explain to students that, by the end of the next lesson, they should expect to answer questions such as these. This is their goal.

### Assessing students' responses

Collect students' responses to the task. Make some notes on what their work reveals about their current levels of understanding and difficulties. The purpose of this is to forewarn you of the issues that will arise during the lesson, so that you may prepare carefully.

We suggest that you do not score students' work. Research shows that this is counterproductive, as it encourages students to compare scores and distracts their attention from how they may improve their mathematics.

Instead, help students to make further progress by asking questions that focus attention on aspects of their work. Some suggestions for these are given in the *Common issues* table on page T-4. These have been drawn from common difficulties observed in trials of this unit.

We suggest you make a list of your own questions, based on your students' work.

### Express Yourself

1. Which of the equations below will answer the following question? Check (✓) all that apply.

"I think of a number, add 7 and then multiply by 4.  
My answer is 80. What was my number?"

$x + 28 = 80$	$4(x + 7) = 80$	$4x + 7 = 80$	$4x + 28 = 80$
---------------	-----------------	---------------	----------------

Explain your answers.

.....

.....

Find the value of  $x$ .

.....

.....

2. Look at the four diagrams below:

Diagram A $2x+4$ Find the Area of the rectangle. 2	Diagram B $2x+2$ Find the Area of the rectangle. 2	Diagram C $2x$ Find the Perimeter of the rectangle. 2	Diagram D $x+1$ Find the Perimeter of the square.
--	--	---	---

Which diagram **does not** result in the expression  $4x + 4$ ? Explain your answer fully.

.....

### Express Yourself (continued)

3. The numbers 5, 6 and 7 are an example of consecutive numbers, as one number comes after another.

Another three consecutive numbers are added together so that the first number, plus two times the second number plus three times the third number gives the total.

Which of these expressions could represent the total? Check (✓) all that apply.

Total = $x + 2x + 3x$	Total = $x + 2x + 2 + 3x + 6$
Total = $x + 2(x + 1) + 3(x + 2)$	Total = $x + (2x + 1) + (3x + 2)$

Explain your answer.

.....

.....

The total of the equation is 170. What are the three consecutive numbers? Explain your answer.

.....

We recommend you either:

- write one or two questions on each student's work, or
- give each student a printed version of your list of questions and highlight the questions for each individual student.

If you do not have time to do this, you could select a few questions that will be of help to the majority of students and write these on the board when you return the work to the students in the follow-up lesson.

Review Copy  
Not for Distribution



<b>Common issues:</b>	<b>Suggested questions and prompts:</b>
<p><b>Applies operations in the wrong order</b>                      For example: The student chooses <math>4x + 7 = 80</math> as an appropriate equation (Q1).                      Or: The student chooses <math>x + 28 = 80</math> as an appropriate equation (Q1).</p>	<ul style="list-style-type: none"> <li>• In this expression, what is the first thing that happens to the number I am thinking of? Then what happens?</li> <li>• What does <math>x</math> represent? What are you adding 7 to?</li> <li>• Is adding 7 and then multiplying by 4 the same as adding 28? How could you check?</li> </ul>
<p><b>Does not recognize all relevant expressions</b>                      For example: The student chooses <math>4(x + 7) = 80</math> as the only appropriate equation (Q1).</p>	<ul style="list-style-type: none"> <li>• How else could you write the expression <math>4(x + 7)</math>?</li> </ul>
<p><b>Does not distinguish between area and perimeter</b>                      For example: The student writes an expression for the area instead of the perimeter of the rectangles in Diagrams C and D (Q2).                      Or: The student writes an expression for the perimeter instead of the area of the rectangles in Diagrams A and B (Q2).</p>	<ul style="list-style-type: none"> <li>• How do you calculate the area of a rectangle?</li> <li>• What does perimeter mean?</li> <li>• Does your expression represent the area or the perimeter of this rectangle?</li> </ul>
<p><b>Assumes the three numbers are equal</b>                      For example: The student selects ‘Total = <math>x + 2x + 3x</math>’ as an appropriate expression (Q3).</p>	<ul style="list-style-type: none"> <li>• What does ‘consecutive’ mean?</li> <li>• What does <math>x</math> represent?</li> <li>• Can you try some numbers to check this works?</li> </ul>
<p><b>Does not multiply all terms in the bracket</b>                      For example: The student selects ‘Total = <math>x + (2x + 1) + (3x + 2)</math>’ as an appropriate expression (Q3).</p>	<ul style="list-style-type: none"> <li>• What does <math>x</math> represent?</li> <li>• How do you write ‘one more than <math>x</math>’ using algebra? Now read the question again: what happens next? What happens if you add two of these numbers together?</li> </ul>
<p><b>Student calculates an incorrect value for <math>x</math> (Q1, Q3)</b></p>	<ul style="list-style-type: none"> <li>• If you substitute your value of <math>x</math> into the left hand side of the equation, does it equal the number on the right hand side?</li> <li>• How will you check whether your value for <math>x</math> is correct?</li> </ul>
<p><b>Does not interpret the solution</b>                      For example: The student does not realize that <math>x</math> represents the number first thought of (Q1).                      Or: The student does not recognize that <math>x = 27</math> is the first of the three consecutive numbers (Q3).</p>	<ul style="list-style-type: none"> <li>• You have found that <math>x = 27</math>. Read the question again. What are the <b>three</b> consecutive numbers?</li> </ul>
<p><b>Completes the task</b></p>	<ul style="list-style-type: none"> <li>• Can you make up a situation that would lead to the equation <math>4(x + 3) = 16</math>?</li> <li>• Could you solve these equations using a different method? What would the method be?</li> </ul>

## SUGGESTED LESSON OUTLINE

### Whole-class introduction (20 minutes)

Give each student a mini-whiteboard, pen, and eraser.

Display Slide P-1 of the projector resource:

**Writing Algebraic Expressions**

**A**

$x+6$

Write an expression for the **area** of this rectangle

4

Area of rectangle = \_\_\_\_\_

*Write an expression for the area of this rectangle on your whiteboard.*

Spend time discussing the expressions students give. Some students may write the expression  $4(x + 6)$  whereas others may apply the distributive law to give  $4x + 24$ . Explain their equivalence by considering how the area of the single rectangle  $4(x + 6)$  may be split into the two smaller areas  $4x$  and  $24$  by drawing a vertical line. Notice whether students make the mistake of writing the expression as  $4x + 6$  or whether they confuse the area of the rectangle with the perimeter.

Display Slide P-2 of the projector resource.

**Writing Algebraic Expressions**

**B**

$x+3$

Write an expression for the **perimeter** of this rectangle

$x$

Perimeter of rectangle = \_\_\_\_\_

*Write an expression for the perimeter of this rectangle on your whiteboard.*

Again, spend time discussing the expressions given by students.

Notice whether students collect like terms to give  $2(2x + 3)$  or  $4x + 6$ , or whether they give an un-simplified expression, for example,  $x + 3 + x + x + 3 + x$ .

Display Slide P-3 of the projector resource:

**Writing Algebraic Expressions**

<b>A</b>	<b>B</b>	<b>C</b>
$x+6$	$x+3$	<div style="border: 1px solid black; border-radius: 50%; padding: 10px; width: fit-content; margin: 0 auto;">                     Think of a number. Multiply it by 4. Then add 6.                 </div>
<div style="border: 1px solid gray; padding: 5px; width: fit-content; margin: 0 auto;">                     Write an expression for the <b>area</b> of this rectangle                 </div>	<div style="border: 1px solid gray; padding: 5px; width: fit-content; margin: 0 auto;">                     Write an expression for the <b>perimeter</b> of this rectangle                 </div>	
4	$x$	

Which two expressions are equivalent?

Ask students to compare the expressions they have written for A and B with the expression that arises from the description in C. Students should be able to identify that  $4x + 6$  is a suitable expression for C and so the expressions for B and C are the same.

Display Slide P-4 of the projector resource:

**Which Equations Describe The Story?**

A pencil costs \$2 less than a notebook.  A pen costs 3 times as much as a pencil.  The pen costs \$9.  Which of the four equations opposite describe this story?	Let $x$ represent the cost of notebook.  A: $3x - 6 = 9$ B: $x - 6 = 9$ C: $3x - 2 = 9$ D: $3(x - 2) = 9$
---	--

Students will often look at the numbers contained within an expression/equation when matching it with a story and as a result, misinterpret the description given.

*Write the equations that you think represent the story on your whiteboard.*

Students should be encouraged to think carefully about this and explore the differences between the four equations. Discuss the responses given and spend some time discussing why equations A and D are correct and why the others are incorrect:

*If  $x$  is the cost of a notebook, what expression will give the cost of a pencil? [ $x - 2$ .]*

*If a pen costs 3 times as much as a pencil, what expression will give the cost of a pen? [ $3(x - 2)$  or  $3x - 6$ .]*

*What mistakes have been made with B and C? [The expression  $x - 2$  has been multiplied by 3 incorrectly in both cases.]*

*OK, so what is the cost of the notebook? [\$5.]*

*Can we check that this fits our equations?*

Explain to students that in the next activity they will be writing and matching equations to stories in a similar way.

**Individual work: writing equations (5 minutes)**

Give each student *Card Set: Stories* (not cut up).

*Here are six stories.*

*Spend 5 minutes on your own writing an equation for each of the stories.*

*In each case, let  $x$  represent the number you are trying to find.*

*Do not worry if you can't write an equation for every story as, later on, you will be working in groups on this.*

In the next activity, students will be given six equations to match up with these stories; some of these may have been simplified or written in a different form. This individual work should, therefore, help students with the matching process as well as providing an opportunity for them to think carefully about the equations and look beyond the surface features.

**Collaborative activity: matching cards (15 minutes)**

Organize students into groups of two or three.

For each group provide a cut-up copy of the *Card Set: Stories* and *Card Set: Equations*.

*The six story cards are the same stories as you have just been looking at.*

*Working together in your group, your job is to match each story with an equation.*

*Use the work you have done individually to help you.*

*Check to see whether any of the equations you have written down match the equations on the cards.*

It is likely that students who have identified correct equations may have written them in a different form to the equations on the card. Encourage them to check whether what they have written is the same. Some students may have an incorrect equation, but assume it is correct. Encourage students to check their work carefully.

While students work in small groups you have two tasks: to make a note of students approaches to the task and to support student reasoning.

**Make a note of student approaches to the task**

Listen and watch students carefully. Note any common errors in algebra and computation. Do students use the distributive law correctly? Do they only multiply part of an expression? Notice the ways students check to see if their card match is correct. Do they substitute back into the equations? Do they know which value  $x$  represents?

Notice the quality and depth of students' explanations. Are students satisfied just to match the cards, or do they explain choices? Do they challenge each other if they disagree on a matched pair?

**Support student reasoning**

Prompt students to explain clearly what expressions mean.

*What does  $x$  represent in this story?*

*What information do you have? What do you need to find out?*

*You've decided how you're going to write [how old James is/the score for Paper 1/the cost of a strawberry chew]. What's the connection between [his age and his dad's age/the scores/the costs of a chew and a lollipop]? How does that help you to write [his dad's age/the score for paper 2/the cost of a lollipop]?*

Encourage students to explain their reasoning carefully and check that all group members are able to justify each choice.

*Jean, you matched these cards. Terry, do you agree that these cards match? Explain please.*

If students finish quickly, ask them to write their own, different stories to match the equation cards.

### Sharing work (10 minutes)

As students finish matching the cards, ask them to jot down the matched pairs on their whiteboards (for example, S1 with E1, S5 with E2, etc.). Then ask one student from each group to visit another group. This way they can compare their own matches with another group's.

The student remaining at the desk is to explain their reasoning for the matched cards to the visiting student.

Students may now want to make changes or additions to their matches, especially if they have visited a group that has matched up different stories to their own. If this is the case, it is important that students are able to explain the new match. They should not just assume that another group's matches are correct without exploring the reasoning used.

### Extending the lesson over two days

If you are taking two days to complete the unit then you may want to end the first lesson here. It is important that students keep a permanent record of the matches that have agreed upon so that they can refer to them in the next lesson. At the start of the second day, allow students time to remind themselves of the matches they have made before holding a whole-class discussion of the processes used when matching the stories with equations and the reasons behind their agreed matches.

### Whole-class discussion (10 minutes)

It is likely that some groups may not have managed to match all six stories with an equation. Spend a few minutes discussing some of the matches the students have made. Survey the students to see if, after sharing their work with another group, they have changed their mind. Ask them to explain and justify their reasoning.

*Harry, which equation did you match with S3? How did you decide?*

*Did anyone match a different equation with this story? Explain your thinking.*

*Which equation is the correct match?*

*Did any group change their mind about a match? Which story equation was it? What did you think it was originally? What did you change it to? Explain why you did this.*

The aim of this discussion is to explore the reasoning behind some of the matches and help students to justify their thinking, not to check that all groups have successfully matched all of the cards.

### Collaborative activity: posters that show steps to solving four equations (20 minutes)

Give each group of students a large piece of poster paper, a marker, and a glue stick.

*Put the cards E5 and E6 and the story cards you've matched with them to one side.*

*Divide your large sheet of paper into quarters.*

*You are now going to work with equation cards E1 – E4.*

*Stick one at the top of each section, along with the matched story.*

*If you haven't managed to match all four of the equation cards with a story yet, just stick down the four equation cards.*

Students don't need to stick the last two sets of cards in place as they are not used in the second matching activity. Nevertheless, if the sheets of paper you have provided are very large, they may wish to do this.

For each group provide a cut-up copy of the *Card Set: Steps to Solving*.

*You are going to explore the steps to solving these four equations.*

*In between each step write a description of the process involved. For example, you may write something like 'divide both sides by 2' or 'add 6 to both sides'. Repeat this until you finally reach a solution.*

*If you find there is more than one method for solving an equation, stick the two solutions side-by-side.*

Once students have completed this work, they can finish any matching of pairs. Then encourage them to add explanations to their posters to show how they arrived at an equation for each of their chosen stories.

As students work, support them as before. Walk around, watch, listen, and check that students are writing a description for each step of the solution process.

The finished poster may look something like this:

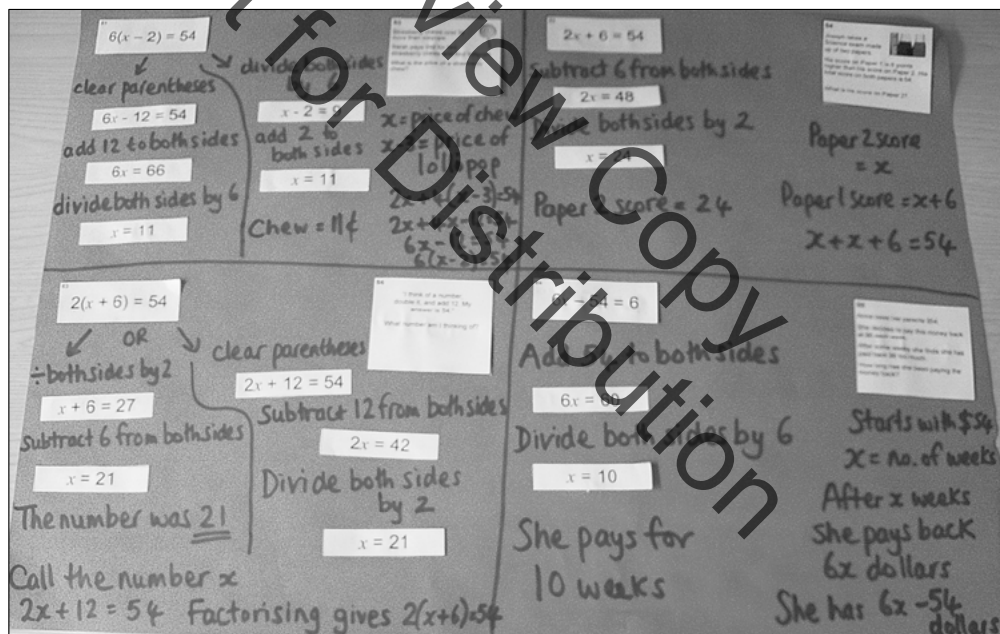

**Whole-class discussion (15 minutes)**

Select two or three students from different groups that have completed a solution for *Equation Cards E1* and/or *E3*. Ask them to explain why there are two methods for solving these equations.

*Which of the two methods is the most efficient?*

*Which method do you prefer? Why?*

*Is there a different method that could be used to solve these equations?*

Students may prefer to clear parentheses, even though this creates an extra step in the solution process.

*What do you need to remember when using the distributive property to clear parentheses? [To multiply **every** term by the term outside.]*

*How else could we clear parentheses? [E.g.  $2(x + 3) = (x + 3) + (x + 3) = x + 3 + x + 3.$ ]*

The focus of this discussion is to explore the processes involved in a range of different approaches, not to promote a particular method.

**Follow-up lesson: review individual solutions to the assessment task (15 minutes)**

Give students their responses to the original assessment task, *Express Yourself* and a copy of the task *Express Yourself (revisited)*.

If you have not added questions to individual pieces of work then write your list of questions on the board. Students should select from this list only the questions they think are appropriate to their own work.

*Look at your written script, answer the questions and revise your response.*

*Make some notes on what you have learned during the lesson/ since you did this task.*

*Now have a go at the second sheet, *Express Yourself (revisited)*. Can you use what you have learned to answer these questions?*

Some teachers give this task as homework.

Not for Review Copy  
Distribution

## SOLUTIONS

### Assessment task: Express Yourself

- The task is to write this sentence using algebra: "I think of a number, add 7 and multiply by 4. My answer is 80."  $4(x + 7) = 80$  and  $4x + 28 = 80$  are two ways of representing this.

Students choosing the other two equations may have not applied the distributive property to one of the terms in the left-hand expression.

$x = 13$  represents the number I was thinking of.

- Diagram A does not describe the algebraic expression  $4x + 4$ . The area of this rectangle is  $4x + 8$ .
- Total =  $x + 2x + 2 + 3x + 6$  and Total =  $x + 2(x + 1) + 3(x + 2)$  are the expressions that match the sentence.

Students may simplify the expression, before solving the equation:

$$\begin{aligned} 6x + 8 &= 170 \\ 6x &= 162 \\ x &= 27 \end{aligned}$$

The consecutive numbers are 27, 28, and 29.

### Lesson task

In the first card matching activity, these are the correct pairs:

- S1 → E5.
- S2 → E6.
- S3 → E1.
- S4 → E2.
- S5 → E4.
- S6 → E3.

These are the matches that provide the 'steps to solving' the Equations on Cards E1 to E4:

#### E1 $6(x - 2) = 54$

Method 1:  $6(x - 2) = 54$

Divide both sides by 6

$$x - 2 = 9$$

Add 2 to both sides

$$x = 11.$$

Method 2:  $6(x - 2) = 54$

Multiply out the brackets

$$6x - 12 = 54$$

Add 12 to both sides

$$6x = 66$$

Divide both sides by 6

$$x = 11.$$

A strawberry chew costs 11¢ (and a lollipop costs 8¢).

#### E2 $2x + 6 = 54$

$$2x + 6 = 54$$

Subtract 6 from both sides

$$2x = 48$$

Divide both sides by 2

$$x = 24.$$

The score for Paper 2 was 24 marks.



**E3  $2(x + 6) = 54$**

Method 1:  $2(x + 6) = 54$

Multiply out the brackets  
 $2x + 12 = 54$   
Subtract 12 from both sides  
 $2x = 42$   
Divide both sides by 2  
 $x = 21$ .

Method 2:  $2(x + 6) = 54$

Divide both sides by 2  
 $x + 6 = 27$   
Subtract 6 from both sides  
 $x = 21$ .

The number I was thinking of was 21.

**E4  $6x - 54 = 6$**

$6x - 54 = 6$   
Add 54 to both sides  
 $6x = 60$   
Divide both sides by 6  
 $x = 10$ .

She has been paying for 10 weeks.

**Assessment task: Express Yourself (revisited)**

1. Alicia's statement can be represented by these equations:

$$3x + 24 = 66 \text{ and } 3(x + 8) = 66.$$

Students choosing the other two equations may have not applied the distributive property to one of the terms in the left-hand expression.

$x$  represents the number Alicia first thought of.

The method used to solve the equation will depend on which representation the student chooses to work with. The correct solution is  $x = 14$ .

2. Diagram A: the perimeter is  $2((2x + 1) + 3) = 2(2x + 4) = 4x + 8$ .

Diagram B: the perimeter is  $2((2x + 2) + 3) = 2(2x + 5) = 4x + 10$ .

Diagram C: the area is  $2(x + 2) \times 2 = 4(x + 2) = 4x + 8$ .

Diagram D: the perimeter of the rectangle is  $2((x + 3) + (x + 1)) = 2(2x + 4) = 4x + 8$ .

Thus the diagrams that match the expression are A, C, and D.

3. The expressions for three consecutive numbers are  $x, x + 1, x + 2$ .

Total =  $3x + 3x + 3 + 3x + 6$  and Total =  $3x + 3(x + 1) + 3(x + 2)$  are the expressions that match the sentence.

Summing the terms gives  $x + x + 1 + x + 2$ . Students may simplify this before or after multiplying by three:

$$3(x + x + 1 + x + 2) = 162 \quad \text{or} \quad 3(3x + 3) = 162$$

$$3x + 3x + 3 + 3x + 6 = 162 \quad \text{or} \quad 9x + 9 = 162$$

$$9x + 9 = 162$$

From this point, the solution methods are the same.

$$9x = 153; x = 17.$$

The consecutive numbers are 17, 18, and 19.

## Express Yourself

1. Which of the equations below will answer the following question? Check (✓) **all** that apply.

“I think of a number, add 7 and then multiply by 4.  
 My answer is 80. What was my number?”

$$x + 28 = 80$$

$$4(x + 7) = 80$$

$$4x + 7 = 80$$

$$4x + 28 = 80$$

Explain your answers.

.....

.....

.....

Find the value of  $x$ .

.....

.....

.....

2. Look at the four diagrams below:

Diagram A	Diagram B	Diagram C	Diagram D
$2x+4$	$2x+2$	$2x$	$x+1$
Find the Area of the rectangle. <span style="float: right;">2</span>	Find the Area of the rectangle. <span style="float: right;">2</span>	Find the Perimeter of the rectangle. <span style="float: right;">2</span>	Find the Perimeter of the square.

Which diagram **does not** result in the expression  $4x + 4$ ? Explain your answer fully.

.....

.....

.....

.....

.....

## Express Yourself (continued)

3. The numbers 5, 6 and 7 are an example of consecutive numbers, as one number comes after another.

Another three consecutive numbers are added together so that the first number, plus two times the second number, plus three times the third number gives the total.

Which of these expressions could represent the total? Check (✓) **all** that apply.

Total = $x + 2x + 3x$	Total = $x + 2x + 2 + 3x + 6$
Total = $x + 2(x + 1) + 3(x + 2)$	Total = $x + (2x + 1) + (3x + 2)$

Explain your answer.

.....

.....

.....

.....

The total of the equation is 170. What are the three consecutive numbers? Explain your answer.



.....

.....

.....

.....

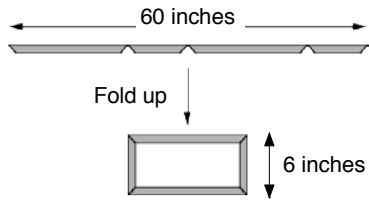
### Card Set: Stories

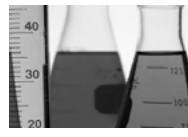
<p><b>S1</b></p>  <p>60 inches</p> <p>Fold up</p> <p>6 inches</p> <p>60 inches of plastic are folded to make a picture frame.</p> <p>The height of the finished frame is 6 inches. How long is the frame?</p>	<p><b>S2</b></p>  <p>Tom is 57 years old.</p> <p>Tom has a son called James.</p> <p>In three years time Tom will be twice as old as James.</p> <p>How old is James?</p>
<p><b>S3</b></p>  <p>Strawberry chews cost 3¢ more than lollipops.</p> <p>Sarah pays 54¢ for two strawberry chews and four lollipops.</p> <p>What is the price of a strawberry chew?</p>	<p><b>S4</b></p>  <p>Joseph takes a Science exam made up of two papers.</p> <p>His score on Paper 1 is 6 points higher than his score on Paper 2. His total score on both papers is 54.</p> <p>What is his score on Paper 2?</p>
<p><b>S5</b></p> <p>Anna owes her parents \$54.</p> <p>She decides to pay this money back at \$6 each week.</p> <p>After some weeks she finds she has paid back \$6 too much.</p> <p>How long has she been paying the money back?</p>	<p><b>S6</b></p> <p>“I think of a number, double it, and add 12. My answer is 54.”</p> <p>What number am I thinking of?</p>

### Card Set: Equations

E1 $6(x - 2) = 54$	E2 $2x + 6 = 54$
E3 $2(x + 6) = 54$	E4 $6x - 54 = 6$
E5 $2x + 12 = 60$	E6 $2(x + 3) = 60$

### Card Set: Steps to Solving

$6x = 60$	$2x = 48$
$6x = 66$	$x - 2 = 9$
$x = 24$	$x + 6 = 27$
$x = 11$	$x = 21$
$6x - 12 = 54$	$2x = 42$
$x = 10$	$x = 11$
$2x + 12 = 54$	$x = 21$

## Express Yourself (revisited)

1. Which of the equations below will answer the following question? Check (✓) **all** that apply.

“I think of a number, add 8 and then multiply by 3.  
 My answer is 66. What was my number?”

$x + 24 = 66$	$3x + 8 = 66$	$3x + 24 = 66$	$3(x + 8) = 66$
---------------	---------------	----------------	-----------------

Explain your answers.

.....

.....

.....

Find the value of  $x$ .

.....

.....

.....

2. Look at the four diagrams below:

Diagram A	Diagram B	Diagram C	Diagram D
$2x+1$	$2(x+1)$	$2(x+2)$	$x+3$
<div style="border: 1px solid black; padding: 5px; width: fit-content; margin: 0 auto;">                     Find the Perimeter of the rectangle.                 </div>	<div style="border: 1px solid black; padding: 5px; width: fit-content; margin: 0 auto;">                     Find the Perimeter of the rectangle.                 </div>	<div style="border: 1px solid black; padding: 5px; width: fit-content; margin: 0 auto; background-color: #e0e0e0;">                     Find the Area of the rectangle.                 </div>	<div style="border: 1px solid black; padding: 5px; width: fit-content; margin: 0 auto;">                     Find the Perimeter of the rectangle.                 </div>
3	3	2	$x+1$

Check (✓) **every** diagram that represents the expression  $4x + 8$ :

Explain your answers.

.....

.....

.....

.....

.....

### Express Yourself (revisited) (continued)

3. Three consecutive numbers are added together and then their sum is multiplied by three. Some of the equations below represent the total using algebra. Check (✓) all that apply.

Total = $3x + 3x + 1 + 3x + 2$	Total = $3x + 3x + 3 + 3x + 6$
Total = $3x + 3(x + 1) + 3(x+2)$	Total = $x + x + 3 + x + 6$

Explain your answers.

.....

.....

.....

.....

The total of the equation is 162. What are the three consecutive numbers? Explain your answer.

.....

.....

.....

.....

Not for Review Copy  
Not for Distribution



# Writing Algebraic Expressions

A

$$x+6$$



Area of rectangle = \_\_\_\_\_

# Writing Algebraic Expressions

**B**

$$x + 3$$

Write an expression for the **perimeter** of this rectangle

$x$

Perimeter of rectangle = \_\_\_\_\_

# Writing Algebraic Expressions

A

$$x+6$$

Write an expression for the **area** of this rectangle

4

B

$$x+3$$

Write an expression for the **perimeter** of this rectangle

$x$

C

Think of a number.  
Multiply it by 4.  
Then add 6.

## Which two expressions are equivalent?

## Which Equations Describe The Story?

A pencil costs \$2 less than a notebook.

A pen costs 3 times as much as a pencil.

The pen costs \$9

Which of the four equations opposite describe this story?

Let  $x$  represent the cost of notebook.

A:  $3x - 6 = 9$

B:  $x - 6 = 9$

C:  $3x - 2 = 9$

D:  $3(x - 2) = 9$

## Mathematics Assessment Project **Classroom Challenges**

These materials were designed and developed by the  
Shell Center Team at the Center for Research in Mathematical Education  
University of Nottingham, England:

**Malcolm Swan,**  
**Nichola Clarke, Clare Dawson, Sheila Evans, Colin Foster, and Marie Joubert**  
with  
**Hugh Burkhardt, Rita Crust, Andy Noyes, and Daniel Pead**

We are grateful to the many teachers and students, in the UK and the US,  
who took part in the classroom trials that played a critical role in developing these materials

The classroom observation teams in the US were led by  
**David Foster, Mary Bouck, and Diane Schaefer**

This project was conceived and directed for  
The Mathematics Assessment Resource Service (MARS) by  
**Alan Schoenfeld** at the University of California, Berkeley, and  
**Hugh Burkhardt, Daniel Pead, and Malcolm Swan** at the University of Nottingham

Thanks also to Mat Crosier, Anne Floyde, Michael Galan, Judith Mills, Nick Orchard, and Alvaro Villanueva who contributed to the design and production of these materials

This development would not have been possible without the support of  
**Bill & Melinda Gates Foundation**

We are particularly grateful to  
**Carina Wong, Melissa Chabran, and Jamie McKee**

The full collection of Mathematics Assessment Project materials is available from

<http://map.mathshell.org>

© 2015 MARS, Shell Center, University of Nottingham  
This material may be reproduced and distributed, without modification, for non-commercial purposes,  
under the Creative Commons License detailed at <http://creativecommons.org/licenses/by-nc-nd/3.0/>  
All other rights reserved.

Please contact [map.info@mathshell.org](mailto:map.info@mathshell.org) if this license does not meet your needs.

## Expressions, Equations and Inequalities

# Lesson 10 of 11

## Restructuring Equations

### Description:

---

Students will solve one and multi-step equations. Students will also explain the steps to solving an equation as follows from the equality of numbers and construct viable arguments to justify solution methods.

### College- and Career-Readiness Standards Addressed:

---

A.5 Rearrange formulas to highlight a quantity of interest, using the same reasoning as in solving equations. For example, rearrange Ohm's law  $V = IR$  to highlight resistance  $R$ .

### Process Readiness Indicator(s) Emphasized:

---

PRI 1: Make sense of problems and persevere in solving through reasoning and exploration.

PRI 2: Reason abstractly and quantitatively by using multiple forms of representations to make sense of and understand mathematics.

PRI 3: Describe and justify mathematical understandings by constructing viable arguments, critiquing the reasoning of others and engaging in meaningful mathematical discourse.

PRI 4: Contextualize mathematical ideas by connecting them to real-world situations. Model with mathematics.

PRI 6: Attend to precision.

PRI 7: Look for and make use of patterns and structure.

Sequence of Instruction

Activities Checklist

Engage

Teacher does a read-a-loud to set the stage for the upcoming activity:

Sam offered special prices on every item in his diner on Dr. Seuss’s birthday (the creative genius behind his successful business). When Sam was “balancing the books”, he could not determine the company’s profits because he failed to record the special sale prices. He remembered that Green Eggs were \$2 and the Today’s Special was \$3. Sam located some of the receipts and a few customers remembered their orders. Sam may have enough clues to determine the birthday prices. There are hundreds of receipts from the day. Let’s help Sam determine which receipts to work with first!

Teacher Displays the Original Menu and the birthday prices that Sam was able to figure out:

<p><i>Green Eggs</i> ..... \$2.25  <i>Regular Eggs</i> ..... \$2.00  <i>Ham</i> ..... \$1.50  <i>Bacon</i> ..... \$1.25  <i>Small Drink</i> ..... \$0.75  <i>Large Drink</i> ..... \$1.00  <i>Today’s Special</i> ..... \$4.25</p>	<p>Birthday Prices                  G = 2.00                  E = ?                  H = ?                  B = 0.75                  S = 0.25                  L = ?                  X = 3.00</p>
--	---

Teacher says: First I will read the background information for each clue that Sam is working with. Next, I will reveal an algebraic equation that represents the situation. You need to replace the variables with the known values for both options. Solve the easier equation!

I.

Sam located an order for Today’s Special, Green Eggs and Large Drink was \$5.50 before tax and tip.

$$X + G + L = 5.50$$

Xavier, a customer, told Sam, “I handed the cashier \$20 and received \$19.50 back”. Let C represent the change in dollars.

$$L = 20 - C$$

- Which equation is easier to solve for the value of L, the large drink?

$$X + G + L = 5.50 \text{ or } L = 20 - C$$

II.

Sally and George both ordered food and told Sam that Sally's order of Ham was  $\frac{1}{10}$  of the cost of George's breakfast. George ended up paying for both meals. George devoured the Special, Green Eggs, Bacon and a Large Drink.

$$\frac{L + X + G + B}{10} = H$$

Sam found a ticket for three orders of Green Eggs, Ham and a Large Drink. It was \$11.25 before Tax and Tip.

$$3(G + H + L) = 11.25$$

- Which equation is easier to solve for H?

$$\frac{L + X + G + B}{10} = H \text{ or } 3(G + H + L) = 11.25$$

III.

Two orders of Ham and Regular Eggs cost \$5.50.

$$2(H + R) = 5.50$$

An employee recalled that Regular Eggs cost \$1.50 more than twice the cost of a drink.

$$R = 2D + 1.5$$

- Which equation is easier to solve for R?

$$2(H + R) = 5.50 \text{ or } R = 2D + 1.5$$

**Solutions:**

$$G = 2.00$$

$$E = 1.50$$

$$H = 1.25$$

$$B = 0.75$$

$$S = 0.25$$

$$L = 0.50$$

$$X = 3.00$$



Teacher asks: Why did some equations seem easier to solve than others? *Once the known values were substituted, the unknown was already isolated.*

Teacher says: Today we are going to learn how to re-write algebraic equations as a strategy that can assist in the problem solving process. This is called solving Literal Equations.

Define the term literal equation, and have students record the definition in their notes.

## Explore

### PRI 7

Have students solve both equations, showing each step in the process.

Solve for x: $2x - 5 = 12$	Solve for x: $nx - d = T$
-------------------------------	------------------------------

Have students write the similarities and differences in their notes.

Whole group discussion:

- What strategies did you use to solve the algebraic equation? The literal equation?
- What did you do differently to solve each equation?
- If you were unsure what property to apply first and next, what could you do to justify your steps and solution?

## Explanation

Remind students that formulas are considered literal equations.

Write the formulas to convert between degrees Celsius and degrees Fahrenheit on the board.

$$\frac{(^{\circ}F - 32)}{1.8} = ^{\circ}C \quad (\text{Fahrenheit to Celsius})$$

$$1.8(^{\circ}C) + 32 = ^{\circ}F \quad (\text{Celsius to Fahrenheit})$$

Ask students:

Which formula would you use to determine degrees Fahrenheit if the temperature is provided in degrees Celsius? Which formula would you use to determine degrees Celsius if degrees Fahrenheit is provided? Explain.

Sometimes it is easier to remember one formula and rearrange it.

Let's solve this formula for F to show that the two equations are equivalent:

$$\frac{(^{\circ}F - 32)}{1.8} = ^{\circ}C \quad (\text{Fahrenheit to Celsius})$$

Note: Students should record the work in their notes.

## Practice Together / in Small Groups / Individually

### PRI 7

The students should solve the literal equations from Task #14: Literal Equations on their own, and then compare their answers with a partner. If they have discrepancies, the students explain their thought process and justify their work. Students are instructed to raise their hands if partners are failing to identify the mistakes or come to a consensus.

INCLUDED IN THE STUDENT MANUAL

### Task #14: Literal Equations

Solve for the indicated variable in the parenthesis.

1.  $P = IRT$  for  $T$
2.  $A + 2(L+W)$  for  $W$
3.  $y = 5x - 6$
4.  $2x - 3y = 8$  for  $y$
5.  $A = \frac{1}{2}h(b + c)$  for  $b$
6.  $V = LWH$  for  $L$
7.  $A = 4\pi r^2$  for  $r^2$
8.  $S = 2(lw + lh + wh)$  for  $w$
9.  $P = 2(l + w)$  for  $l$
10.  $A = 2\pi r^2 + 2\pi rh$  for  $h$
11.  $y - y_1 = m(x - x_1)$  for  $x$

### Task #14: Literal Equations KEY

1.  $T = \frac{P}{IR}$

5.  $b = \frac{2A}{h} - c$

9.  $I = \frac{P - 2w}{2}$

2.  $W = \frac{A - 2L}{2}$

6.  $L = \frac{V}{WH}$

10.  $h = \frac{A - 2\pi r^2}{2\pi r}$

3.  $x = \frac{y + 6}{5}$

7.  $r^2 = \frac{A}{4\pi}$

11.  $x = \frac{y - y_1 + mx_1}{-m}$

4.  $y = \frac{8 - 2x}{-3}$

8.  $w = \frac{S - 2h}{2l + 2h}$

Additional practice problems can be found at: [http://users.bloomfield.edu/department/tutorial/ACF\\_94/Documents/Class\\_Notes/PRACTICE\\_WORKSHEETS/LITERAL\\_EQUATIONS\\_WORKSHEET.doc](http://users.bloomfield.edu/department/tutorial/ACF_94/Documents/Class_Notes/PRACTICE_WORKSHEETS/LITERAL_EQUATIONS_WORKSHEET.doc)

[https://www.mcckc.edu/tutoring/docs/br/math/equat\\_inequ/Practice\\_Solving\\_Literal\\_Equations.pdf](https://www.mcckc.edu/tutoring/docs/br/math/equat_inequ/Practice_Solving_Literal_Equations.pdf)

### Evaluate Understanding

Students will return to Lesson 3, Task #6: Creating Expressions. Set each expression equal to  $T$ , the total number of tiles in any given figure in the sequence. Solve each equation for  $n$  in terms of  $T$ .

- Summarize the process of solving a literal equation.

and/ or

- What would happen if you solved a literal equation such as for a given variable such as  $R$  and substituted the value of  $R$  into the original equation? Explain.

### Independent Practice:

Independent practice can be found at:

- [https://www.khanacademy.org/math/algebra/solving-linear-equations-and-inequalities/solving\\_for\\_variable/e/solving\\_for\\_a\\_variable](https://www.khanacademy.org/math/algebra/solving-linear-equations-and-inequalities/solving_for_variable/e/solving_for_a_variable)
- [https://www.khanacademy.org/math/algebra/solving-linear-equations-and-inequalities/solving\\_for\\_variable/e/manipulating-formulas](https://www.khanacademy.org/math/algebra/solving-linear-equations-and-inequalities/solving_for_variable/e/manipulating-formulas)

### Resources/Instructional Materials Needed:

Projector  
White Boards and Markers  
Academic Notebook  
Student Manual Task #14

## Expressions, Equations and Inequalities

# Lesson 11 of 11

## Inequalities

### Description:

---

Students will explore the connection between equality and inequality.

### College- and Career-Readiness Standards Addressed:

---

- EE.8 Use variables to represent quantities in a real-world or mathematical problem, and construct simple equations and inequalities to solve problems by reasoning about the quantities.
- A.4 Solve linear equations and inequalities in one variable, including equations with coefficients

### Process Readiness Indicator(s) Emphasized:

---

PRI 1: Make sense of problems and persevere in solving through reasoning and exploration.

PRI 2: Reason abstractly and quantitatively by using multiple forms of representations to make sense of and understand mathematics.

PRI 3: Describe and justify mathematical understandings by constructing viable arguments, critiquing the reasoning of others and engaging in meaningful mathematical discourse.

PRI 4: Contextualize mathematical ideas by connecting them to real-world situations. Model with mathematics.

PRI 7: Look for and make use of patterns and structure.

Sequence of Instruction

Activities Checklist

### Engage

**PRI 7**

Before beginning the lesson, check for students' prior understanding of the terms included in this lesson, in particular: value, variable, equation, inequality, expression, at most, at least, no more than, maximum, minimum and no less than.

Prompt students with the following questions: Which of the following are equations?

- a)  $2n - 3 = 11$     b)  $3x > 7$     c)  $b - 3 + 12$     d)  $15 + m$

What is the difference between an equation and an expression? What is the difference between an equation and an inequality?

### Explore

**PRI 1**

Esteban has \$50.00 to spend at Six Flags.

**PRI 2**

He wants to ride a few of the roller coasters and play some of the games. The student pass into the park grants unlimited roller coaster rides, and costs \$27. How much money can Esteban spend on games?

Have students discuss as a whole group. *He has \$23 left to spend on games.*

Esteban has decided that he just wants to ride the roller coasters and eat Sno-cones. How many Sno-cones could Esteban buy if each Sno-cone costs \$3.50?

Could Esteban buy 6 Sno-cones? Why or why not? Could he buy 10 Sno-cones? Why or why not?

### Explanation

**PRI 1**

As a whole group, ask students to consider the statements  $3.50c = 23$  and  $3.50c < 23$ .

**PRI 2**

Call on specific students to answer the following questions: Is there more than one value of  $c$  that makes each statement true? How are the solutions different for each statement?

Students should arrive at the conclusion that there is one solution for an equation, and the inequality has a range of solutions.

### Practice Together / in Small Groups / Individually

Students should work in pairs for the following scenarios:

INCLUDED IN THE STUDENT MANUAL

**Task #15: Inequalities**

**Scenario #1:**

The cash prize at BINGO is \$240, and there were three winners in round one. If each winner receives the same amount of money, what amount could each winner receive?

Write an equation to represent the situation and determine a solution.

---

Suppose we know that each participant paid \$3 for 4 BINGO cards, and the cash prize went up to \$500. If each winner is to receive \$50, how many winners could they have at BINGO next week?

---

**Scenario #2:**

Erica went in the store to buy a loaf of bread and gallon of milk. The milk costs \$2.99 a gallon. Her mom only gave her \$5 to spend.

Write an inequality to represent the situation.

---

What is a possible cost of the loaf of bread?

---

Is there more than one possible value? Why or why not?

---

---

---

**Scenario #1:**

The cash prize at BINGO is \$240, and there were three winners in round one. If each winner receives the same amount of money, what amount could each winner receive?

Write an equation to represent the situation and determine a solution.  $3x = 240$ , where  $x$  is the amount of money received by each winner; each winner receives \$80

Suppose we know that each participant paid \$3 for 4 BINGO cards, and the cash prize went up to \$500. If each winner is to receive \$50, how many winners could they have at BINGO next week?

**Scenario #2:**

Erica went in the store to buy a loaf of bread and gallon of milk. The milk costs \$2.99 a gallon. Her mom only gave her \$5 to spend.

Write an inequality to represent the situation.  $2.99 + b \leq 5.00$ , where  $b$  is the cost of bread.

What is a possible cost of the loaf of bread? *The loaf of bread must be \$2.01 or less.*  
Is there more than one possible value? Why or why not? *There are many possible answers, as long as the price of the bread is less than or equal to \$2.01.*

### Evaluate Understanding

- PRI 2**
  - PRI 3**
  - PRI 4**
- Prompt students to create a scenario similar to the ones in the lesson today. Then, have them trade their scenarios with a partner.

### Closing Activity

- PRI 2**
  - PRI 4**
- As a whole group, prompt students with the following situation (can be found in the Student Manual):

INCLUDED IN THE STUDENT MANUAL

#### Task #16: Closing Activity and Independent Practice

Andrew bought a tie and dress shirt and didn't spend over \$45. If the shirt cost \$30, how much was the tie?

\_\_\_\_\_

How could you represent this situation?

\_\_\_\_\_

\_\_\_\_\_

\_\_\_\_\_

What could the cost of the tie be?

\_\_\_\_\_

Is there more than one possible value? Why or why not?

\_\_\_\_\_

\_\_\_\_\_

\_\_\_\_\_

\_\_\_\_\_

### Independent Practice:

Each student must come up with a representation of an inequality and solution for the following scenario:

INCLUDED IN THE STUDENT MANUAL

#### Task #16: Lesson 11 - Closing Activity and Independent Practice contd.

**Set up and solve an inequality that represents the following:**

You and a friend are looking online for a summer job. There are two jobs that you are interested in. The first one pays \$20 per hour, but you have to pay \$160 for the company uniform. The second job requires no uniform but only pays \$12 per hour. Your friend doesn't want to pay for the uniform, but you would like to make more money per hour. How might you convince your friends to take the first job with you?

---

---

---

---

---

---

---

Not for Review Copy  
Distribution

### Resources/Instructional Materials Needed:

- Student Manual pages for this lesson
- Dry erase boards (optional)
- Student Manual Task #15 and Task #16

### Notes:

---

---

---

---

---

---

---

---

---

---



# SREB

## SREB Readiness Courses

# Ready for High School: Math

Math Unit 5  
Geometry

Not for Review Copy Distribution

Southern  
Regional  
Education  
Board

592 Tenth Street, NW  
Atlanta, GA 30318  
(404) 875-9211

[www.sreb.org](http://www.sreb.org)



## Unit 5 . Geometry

### Overview

This unit will aid students in understanding how to draw, translate, and describe geometrical figures, understand congruence, use the Pythagorean Theorem and discuss relationships between different shapes in the context of real world mathematical problems.

### Standards:

Draw, construct, and describe geometrical figures and describe the relationships between them.

- G.1 Draw, construct, and describe geometrical figures and describe the relationships between them.
- G.3 Describe the two-dimensional figures that result from slicing three dimensional figures, as in plane sections of right rectangular prisms and right rectangular pyramids.
- G.4 Use facts about supplementary, complementary, vertical, and adjacent angles in a multi-step problem to write and solve simple equations for an unknown angle in a figure.
- G.5 Solve real-world and mathematical problems involving area, volume, and surface area of two and three-dimensional objects.

Understand congruence and similarity using physical models, transparencies, or geometry software.

- G.6 Verify experimentally the properties of rotations, reflections, and translations.
- G.7 Understand that a two dimensional figure is congruent to another if the second can be obtained from the first by a sequence of rotations, reflections, and translations; given two congruent figures, describe a sequence that exhibits the congruence between them.
- G.8 Describe the effect of dilations, translations, rotations, and reflections on two-dimensional figures using coordinates.
- G.10 Use informal arguments to establish facts about the angle sum and exterior angle of triangles, about the angles created when parallel lines are cut by a transversal. For example, arrange three copies of the same triangle so that the sum of the three angles appears to form a line, and give an argument in terms of transversals why this is so.

Understand and apply the Pythagorean Theorem.

- G.11 Explain a proof of the Pythagorean Theorem and its converse.
- G.12 Apply the Pythagorean Theorem to determine unknown side lengths in right triangles in real-world and mathematical problems in two and three dimensions.

### Prior Scaffolding Knowledge/Skills:

---

- Draw points, lines, line segments, rays, angles (right, acute, obtuse), and perpendicular and parallel lines. Identify these in two dimensional figures.
- Recognize a line of symmetry for a two dimensional figure as a line across the figure such that the figure can be folded along the line into matching parts. Identify line symmetric figures and draw lines of symmetry.
- Understand that attributes belonging to a category of two dimensional figures also belong to all subcategories of that category. For example, all rectangles have four right angles and squares are rectangles, so all squares have four right angles.
- Classify two dimensional figures in a hierarchy based on properties.
- Draw polygons in the coordinate plane given coordinates for the vertices; use coordinates to find the length of a side joining points with the same first coordinate or the same second coordinate. Apply these techniques in the context of solving real world and mathematical problems.

### Essential Questions:

---

- What are the various types and properties of triangles and quadrilaterals?
- What conclusions can you make about the properties of rotations, reflections, and transformations of geometric figures?
- What is the relationship of the angles created by two parallel lines when cut by a transversal?
- What does it mean for figures to be congruent to each other?
- What polygonal regions result from slicing three dimensional shapes by a plane?
- What is the relationship among the lengths of the sides of a right triangle?

## Lesson Progression Overview:

Lesson Big Idea	Lesson Details	Content Standards	Process Readiness Indicators
<b>Lesson 1: Entry Event</b>	Students will be introduced to this unit using a hands-on lesson requiring them to apply their knowledge of area and surface area and applying it to a real-world problem.	G.5 G.12	PRI 1 PRI 2 PRI 3 PRI 6
<b>Lesson 2: Angles</b>	This lesson uses a discovery approach to identify the special angles formed when a set of parallel lines is cut by a transversal. During this lesson students identify angle pairs and the relationship between the angles. Students use these relationships to make conjectures about which angle pairs are considered special angles.	G.4 G.10	PRI 1 PRI 3 PRI 10
<b>Lesson 3: Triangles and Angles</b>	Students will connect their knowledge about lines and angles to deduce the Triangle Angle Sum Theorem. They will then experiment with a GeoGebra based computer model to investigate their findings. Students will ultimately use the Triangle Angle Sum Theorem to write and solve equations and find missing angle measures in a variety of examples.	G.10	PRI 3 PRI 5 PRI 8 PRI 9 PRI 10
<b>Lesson 4: Quadrilaterals</b>	Students learn to classify quadrilaterals, including trapezoids, with a focus on different types of parallelograms. They learn the relationships among rectangles, squares, and rhombuses as different types of parallelograms.	G.1	PRI 3 PRI 5 PRI 10
<b>Lesson 5: FAL – Describing and Defining Quadrilaterals</b>	This lesson unit is intended to help you assess how well students are able to: <ul style="list-style-type: none"> <li>Name and classify quadrilaterals according to their properties.</li> <li>Identify the minimal information required to define a quadrilateral.</li> <li>Sketch quadrilaterals with given conditions.</li> </ul>	G.2	PRI 3 PRI 6 PRI 7 PRI 9 PRI 10
<b>Lesson 6: Slicing 3-D figures</b>	In this lesson, students will sketch, model, and describe cross sections formed by a plane passing through a three dimensional figure.	G.3	PRI 1 PRI 2 PRI 4 PRI 8 PRI 10
<b>Lesson 7: Transformations</b>	Students are introduced to geometric transformations, specifically translations, rotations, reflections and dilations. They learn how, using physical models and geometry software, to perform the transformations, and how to map one figure into another using these transformations. This lesson will provide opportunities for students to understand congruence.	G.6 G.7 G.8	PRI 1 PRI 2 PRI 6 PRI 10

Lesson Big Idea	Lesson Details	Content Standards	Process Readiness Indicators
<b>Lesson 8: FAL – Representing and Combining Transformations</b>	<p>This lesson will help your students be able to:</p> <ul style="list-style-type: none"> <li>• Recognize and visualize transformations of 2D shapes.</li> <li>• Translate, reflect and rotate shapes, and combine these transformations.</li> <li>• It also will aide in encouraging discussion on some common misconceptions about transformations.</li> </ul>	<p>G.9 G.10 G.11</p>	<p>PRI 1 PRI 3 PRI 5 PRI 6 PRI 7 PRI 8 PRI 9 PRI 10</p>
<b>Lesson 9: Pythagorean Theorem/ Distance Formula</b>	<p>Using computers and the applet, the students will be introduced to Pythagorean theorem. They will learn and discover how the theorem works. They will go through the applet and answer the explore questions with their team. Once the students have a good grasp on the Pythagorean Theorem they will apply their knowledge through the Pythagorean Crime Stoppers activity.</p>	<p>G.11 G.12</p>	<p>PRI 1 PRI 2 PRI 3 PRI 4</p>

Not for Review Copy  
Not for Distribution

## Geometry

# Lesson 1 of 9

## Introductory Assignment

### Description:

Students will be introduced to this unit using a hands-on lesson requiring them to apply their knowledge of area and surface area and applying it to a real-world problem.

### College- and Career-Readiness Standards Addressed:

- G.5 Solve real-world and mathematical problems involving area, volume, and surface area of two- and three-dimensional objects.
- G.12 Apply the Pythagorean Theorem to determine unknown side lengths in right triangles in real-world and mathematical problems in two and three dimensions.

### Process Readiness Indicators Emphasized:

- PRI 1: Make sense of problems and persevere in solving through reasoning and exploration.
- PRI 2 Reason abstractly and quantitatively by using multiple forms of representations to make sense of and understand mathematics.
- PRI 3: Construct viable arguments and critique the reasoning of others.

Sequence of  
Instruction

Activities Checklist

### Engage

#### Entry Event

In this lesson, found at <https://www.yummymath.com/2017/wrapping-presents-on-the-diagonal-2/>, students will determine if the traditional method or the method that is shown in the video is the most efficient way to wrap a present.

1. Group students in pairs by varying abilities.
2. Direct students to their student manual to Task #1:How Much Wrapping Paper Can You Save?
3. Lead a class discussion about what type of figure the box is? How do we describe the box (dimensions)?
4. Have the students watch the video: <https://www.youtube.com/watch?v=TNqc2yWZtE>

Demonstrate the Sara Santos Method to the students (this method will also be included in the student manual).

*Formula:  $w$ =length of wrapping paper edge necessary to wrap a present diagonally=*

*diagonal across the largest face of the box (the face or rectangle made up of the two longest sides of the box) + 1.5 \* height (the other dimension).*

## Explore

**PRI 2**  
**PRI 3**  
**PRI 6**

Provide each pair with two different size rectangular prism boxes. (These boxes should have a square face.) Once the students have watched the video, and had time to explore the Sara Santos formula, have the students measure the dimensions of their first box. Engage students in quantitative reasoning practices that include attending to the meaning of quantities and considering the units involved. Ask the students to attend to precision when measuring the boxes and wrapping paper.

The students will complete questions one through four on Task #1: How Much Wrapping Paper Can you Save? in the student manual.

### INCLUDED IN THE STUDENT MANUAL

#### Task #1: How Much Wrapping Paper Can You Save?

You were given two rectangular prisms with which you will explore and compare Sara Santos' method for wrapping boxes to a more traditional wrapping method.

#### Box #1

- Using Sara Santos' formula, calculate the dimensions and square inches of paper that you will need for wrapping a present with her diagonal method.
  - Dimensions:  
Length = \_\_\_\_\_ Width = \_\_\_\_\_ Height = \_\_\_\_\_
  - Square wrapping paper area required: \_\_\_\_\_
- Use the amount of wrapping paper you calculated, wrap the present. Did you have enough wrapping paper using the Sara Santos' method and formula?

---

---

---

- Calculate the amount of wrapping paper necessary for wrapping the same box in the more traditional way.

---

---

- Can you figure out a general way (like a formula) for calculating the amount of wrapping paper necessary for this traditional method of wrapping?

---

---

**Box #2**

5. Calculate the following for the second box:
- a. Dimensions:  
Length = \_\_\_\_\_ Width = \_\_\_\_\_ Height = \_\_\_\_\_
- b. Square wrapping paper required using:
1. Traditional method: \_\_\_\_\_
  2. Sara Santos method: \_\_\_\_\_
6. Use the amount of wrapping paper calculated for the second box and then wrap your present. Did you have enough wrapping paper using each method and formula?

7. What percent of paper does wrapping using the unconventional method save over the traditional method?

(Following lesson 9, students will revisit this lesson and use the Pythagorean Theorem to find the diagonal.)

1. Using the Sara Santos' formula, calculate the dimensions and square inches of paper that you will need for wrapping a present with her diagonal method.
  - a. Dimensions: Length = \_\_\_\_\_ Width = \_\_\_\_\_ Height = \_\_\_\_\_
  - b. Square wrapping paper area required **Sample solution – 6 x 6 x 4 boxes**  
**Sara Santos method =  $6\sqrt{2} + 3/2 \cdot 4 \sim 8.5 + 6 \approx 14.5$**   
**Square wrapping paper area required =  $14.5 \times 14.5 \approx 220.25$**
2. Now have the students use the amount of wrapping paper they calculated and wrap their present. Did you have enough wrapping paper using this method and formula?
3. Use the video to help you calculate the wrapping paper necessary for wrapping the same present in the more traditional way. **Sample solution- for 6 x 6 x 4 box:**  
**Width =  $2.25" + 6" + 2.25"$  Dimensions  $10.5" \times 21"$  b. Square wrapping paper area required = 220.5 square inches**

**Commentary for the Teacher:** You may want to have students wrap the box using the traditional method and have them then measure length and width of the paper they needed and calculate area.

4. Can you figure out a general way (like a formula) for calculating the amount of wrapping paper necessary for this method of wrapping? **Width = slightly greater than  $2 \cdot h + w$  Length = slightly greater than  $2 \cdot h + l$**

**Commentary for the Teacher:** This is a good time to lead a class discussion about surface area.



Now, using the second box from Task #1, have each group complete questions five to seven in the student manual.

5. Calculate the following for the second box:
  - a. Dimensions: Length =      Width =      Height =
  - b. Square wrapping paper required using
    1. Traditional method
    2. Sara Santos method
6. Now have the students' use the amount of wrapping paper they calculated for the second present and then wrap their present. Did you have enough wrapping paper using each method and formula?

Lead a class discussion about the various methods of wrapping a present. How are the two methods different? How are they alike? Did the Sara Santos' formula help? If so, how?

Ask the groups to construct viable arguments and critique the reasoning of others as they address the following questions:

7. What percent of paper does wrapping using the unconventional method save over the traditional method? *Solution for sample listed above:  $220.5 - 210.25 = 10.25$  square inches*  
 *$\% \text{ saved} = \frac{10.25}{220.5} \cdot 100\% = 4.65\%$*

Students can compare their two quantities of necessary paper and decide what percent or fraction of paper is saved.

## Explanation

**PRI 2**  
**PRI 3**

Students will demonstrate flexible use of strategies and methods while reflecting on what method and formula would work best with the traditional method/unconventional method of wrapping a present. Students will also construct viable arguments and critique the reasoning of others using the following questions in a whole class discussion:

1. How did your group solve the problem? Which method of wrapping does your group prefer? Why do they prefer one method over the other?
2. What are some variables that might cause the different methods to not work all the time?
3. What is some advice or help you could give a student who is struggling to solve the wrapping paper problems?

## Evaluate Understanding and Closing Activity

The students will use what they learned in their groups and the class discussion to help them answer the questions presented on Task #2: "Let's Experiment" in the Student Manual.

INCLUDED IN THE STUDENT MANUAL

### Task #2: Let's Experiment

Most packages do not have a square face. Do you think this method will work if our box has different dimensions?

**Traditional**

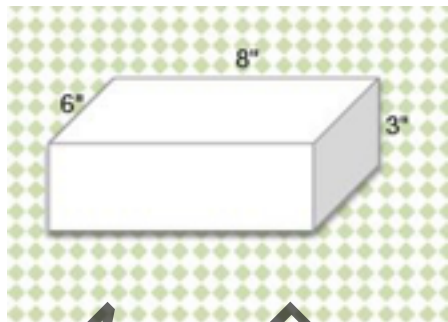

**Unconventional/Diagonal**

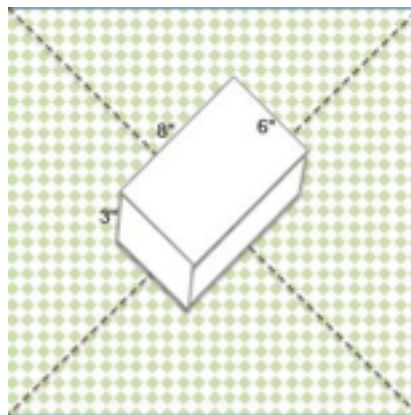

1. What size wrapping paper will you need to wrap this box traditionally?
  - a. Dimensions:  
 Length = \_\_\_\_\_ Width = \_\_\_\_\_ Height = \_\_\_\_\_
  - b. Square wrapping paper required \_\_\_\_\_
2. What size wrapping paper will you need to wrap the present using the Unconventional/Diagonal method?
  - a. Dimensions:  
 Length = \_\_\_\_\_ Width = \_\_\_\_\_ Height = \_\_\_\_\_
  - b. Square wrapping paper required \_\_\_\_\_
3. Show your calculations to demonstrate whether the unconventional method will actually cover the package.
4. What percent of wrapping paper would be saved using the unconventional/diagonal method?
5. Why does the diagonal method work?

Solution:

1. What size wrapping paper will you need to wrap this box traditionally?

a. Dimensions:

Width =  $8 + 1.7 + 1.7 = 11.4$ " Let's say 11.5 inches wide

Length =  $6 + 6 + 3 + 3 + 0.5$  overlap = 18.5 inches long

b. Square wrapping paper area required:

$11.5 \times 18.5 = 212.75$  square inches of wrapping paper.

2. What size wrapping paper will you need to wrap the present using the Unconventional/Diagonal method?

a. Dimensions:

Diagonal of the top of the box is 10 inches So, the edge of the square piece of wrapping paper would need to be  $10 + 1.5 \cdot 3 = 14.5$  inches

b. Square wrapping paper area required:

$4.5 \times 14.5 = 210.25$  square inches

Have each group explain to the class why they think the diagonal method works.

Solution: The diameter of your wrapping paper is 20.51". That gives 10.2505" on either half of the long dimension of the paper. 4" of that half will be used to wrap the bottom face. 3 more inches of that half will be used to wrap the end face.

### Resources/Instructional Materials Needed:

---

Additional wrapping paper activity and resource:

<https://www.yummymath.com/2017/wrapping-presents-on-the-diagonal-2/>

Task #1: How Much Wrapping Paper Can You Save?

Task #2: Let's Experiment

Rulers

Wrapping Paper

Scissors

Tape

## Geometry

# Lesson 2 of 9

## Special Angle Relationships

### Description:

In this lesson students will discover the special angles formed when a set of parallel lines is cut by a transversal. Students will use this relationship to make conjectures about which angle pairs are considered special angles and how they are related.

### College- and Career-Readiness Standards Addressed:

- G.4 Use facts about supplementary, complementary, vertical, and adjacent angles in a multistep problem to write and solve simple equations for an unknown angle in a figure.
- G.10 Use informal arguments to establish facts about the angles created when parallel lines are cut by a transversal.

### Process Readiness Indicators Emphasized:

- PRI 1: Make sense of problems and persevere in solving through reasoning and exploration.
- PRI 3: Construct viable arguments and critique the reasoning of others.
- PRI 10: Reflect on mistakes and misconceptions to improve mathematical understanding.

Sequence of  
Instruction

Activities Checklist

### Engage

► **Commentary for the Teacher:** We recommend grouping students by like abilities throughout this activity. This will allow students to work at their own level and to be an active participant in the learning process.

Using a Think-Pair-Share Model, students will complete a formative assessment (Task #3: Special Angles Intro) to activate prior knowledge of parallel lines, supplementary angles and vertical angles.

► **Commentary for the Teacher:** In the Think-Pair-Share Model, a problem is posed, students have time to think about it individually and then they work in pairs to solve the problem and share their ideas with the class. Think-Pair-Share helps students develop conceptual understanding of a topic, develop the ability to filter information and draw conclusions, and develop the ability to consider other points of view.

This lesson and supporting information for the teacher can be found at:  
<http://www.cpalms.org/Public/PreviewResourceLesson/Preview/26664>

INCLUDED IN THE STUDENT MANUAL

### Task #3: Special Angles Intro Questions

Use the diagram to answer questions 1 – 4.

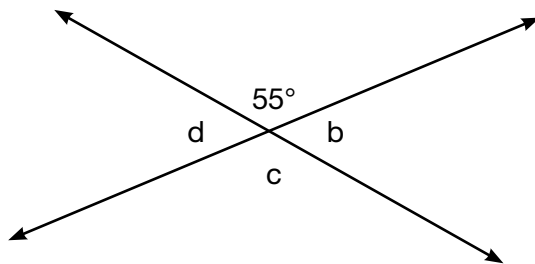

1. What is the relationship between angles  $b$  and  $d$ ?  
\_\_\_\_\_
2. What is the relationship between  $c$  and  $d$ ?  
\_\_\_\_\_
3. What is the measure of angle  $d$ ?  
\_\_\_\_\_
4. What is the measure of angle  $c$ ?  
\_\_\_\_\_

Task #3

Special Angles Intro Questions: Use the diagram to answer questions 1 – 4.

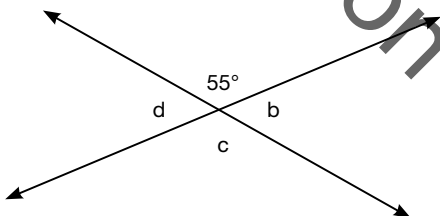

1. What is the relationship between angles  $b$  and  $d$ ? (vertical angles that are congruent)
2. What is the relationship between  $c$  and  $d$ ? (sum of degrees = 180, therefore, they are supplementary angles)
3. What is the measure of angle  $d$ ? (125 degrees)
4. What is the measure of angle  $c$ ? (55 degrees)

Through class discussion, students will persevere in solving through reasoning and exploration. Possible class discussion questions:

- What do we call two lines that cross?
- Is there another name for two lines that cross in a special way?

- What is formed at the intersection of the two lines?
- When skateboarding what do you call a full circle? A half circle?
- What part of the picture represents a half circle?
- What is the measure?
- In the picture which angles represent the half circle?
- What would be the total of these angles?
- What do you remember about angles that form a straight angle?
- What are these angles called?

After discussion, give students an opportunity to fill in the first seven words on Task #4 in the student manual “Special Angles Vocabulary Graphic Organizer.” Monitor students to ensure accurate information is being recorded.

INCLUDED IN THE STUDENT MANUAL

**Task #4: Special Angles Vocabulary Graphic Organizer**

Vocabulary	Sketch	Angle Relationship	Definition
Parallel Lines			
Perpendicular Lines			
Vertex			
Transversal			

Vocabulary	Sketch	Angle Relationship	Definition
Complementary Angles			
Supplementary Angles			
Vertical Angles			
Corresponding Angles			
Alternate Exterior Angles			
Alternate Interior Angles			
Same Side Exterior Angles			
Same Side Interior Angles			

Not for Review Copy  
Distribution

## Explore

### PRI 3

Display the Power Point “Parallel Lines Discovery Activity” found at

<http://www.cpalms.org/Public/PreviewResourceLesson/Preview/26664>

Students will use Task #5: Special Angle Pairs Investigation in the Student Manual. Draw the parallel lines following the directions on the power point presentation, and complete the investigation in the Student Manual.

The “angle pieces” that student need to complete this task can be copied and cut from the template provided at the end of this lesson. Cut up the template into pieces to be used during the activity. Using colored card stock is makes working with easier. Put each set of pieces into a sandwich bag for ease in distribution.

#### INCLUDED IN THE STUDENT MANUAL

#### Task #5: Special Angle Pair Investigation

Put a dot on the top left margin. On the right count down 5 lines and put a dot. Connect the two dots with a straight line. From the dot on the top left, count down 5 lines and put a dot. From the right margin dot, count down 5 lines and put a dot. Connect these two dots with a straight line. From the top left margin count down 10 lines put a dot. Connect this dot to the top right margin. Label the angles and the lines as you see on the projector.

On the lines below explain how you know the first two lines are parallel.



Do you think the angles formed by the transversal (intersecting line) have a relationship? Explain.

---



---



---

Using the pieces in your plastic bag, identify the relationship between the angles formed when parallel lines are cut by a transversal. Write the angle pair in the correct column (use the word “and” between the angles).

Congruent	Supplementary	No Relationship

When you have finished identifying all of the angle relationships, there should be 28, check your findings with your group.

Write a definition for each word.

Vocabulary Word	Definition
Corresponding	
Interior	
Exterior	
Alternate	
Same side	

**When you have completed your definitions please ask for the special angles your group will be investigating.**

Discuss the meanings of the words and identify the angles that your group believes match the special angles given. Be prepared to defend your choices as you present your findings to the class. Use the space below to help develop your presentation. Include in your presentation the degree relationship the angles share.

During this time, circulate, observing student work and group discussions. Possible guiding question:

- What can you tell about the angles you see?
- What do you notice about the opposite angles?
- What shape is formed by all the angles at each intersection?"

**Commentary for the Teacher:** Although the first task is individual student work, students are sharing ideas in their groups. Students come together in their groups to discuss their findings and reach group consensus on the relationship between the angles formed.

Students will construct viable arguments and critique the reasoning of others. When groups have reached consensus the teacher will provide feedback based on their completed activity. Any “no relationship” angles will be noted, so that the teacher may ask guiding questions.

Task #5:

Special Angle Pairs Investigation

Key:

Congruent	Supplementary	No Relationship
1 ≅ 5      1 ≅ 4	1 is supplementary to 2	1 and 6
1 ≅ 8	1 is supplementary to 3	1 and 7
3 ≅ 7      3 ≅ 6	2 is supplementary to 4	2 and 8
2 ≅ 3	3 is supplementary to 4	2 and 5
2 ≅ 6      2 ≅ 7	3 is supplementary to 5	3 and 8
4 ≅ 8	4 is supplementary to 6	4 and 7
4 ≅ 5      5 ≅ 8		
6 ≅ 7		

**Commentary for the Teacher:** Questions for Task #5

What do you have to find out?

What looks familiar? What looks different? What do the parts of the picture represent? How do the pieces represent these parts? What would help you organize your work? What is the same about the parts of the picture?

What is a vertex?

What part of the angle is the vertex? How does this help you identify the relationship?

Remediation for Task #5

Students don't know what the vertex is. Use the graphic organizer which should have the first seven vocabulary words completed.

Students are not placing vertex on top of vertex. Use the document camera to show placement of the angles when trying to identify if they are congruent

Students say that the angles are not congruent because the side lengths are not the same. Direct students to the fact that it is at the vertex that the angle is created and the measure is determined

Students do not match vertex to vertex when identifying supplementary relationship. Use the document camera to show placement of vertex next to vertex.

Direct students to their vocabulary graphic organizer to clarify congruent and supplementary relationships. Corresponding angles appear to be the most difficult – talk about a live broadcast and how it is bringing you the action from another spot to your home. Guide discussion to include how the broadcast is allowing us to “occupy” the same spot as the reporter. Thus getting to the definition for corresponding angles.

**Commentary for the Teacher:** Students can present their information using the diagram from the Power Point “Parallel Lines Discovery Activity.”

## Explanation

PRI 3  
PRI 10

Groups share their discoveries with the class for discussion. Students should be given the opportunity to provide feedback on the context and discoveries. Since more than one group will have the same special angle pair, groups will compare and discuss choice of angles. Students will reflect on mistakes and misconceptions to improve mathematical understanding. Class consensus will be reached for each special angle pair.

## Practice Together / in Small Groups / Individually

With a “similar-ability” partner, have students complete Task #6: Working With Parallel lines Cut by a Transversal in their Student Manual.

INCLUDED IN THE STUDENT MANUAL

### Task #6: Working with Parallel lines Cut by a Transversal

Use the following figure to answer questions 1–4.

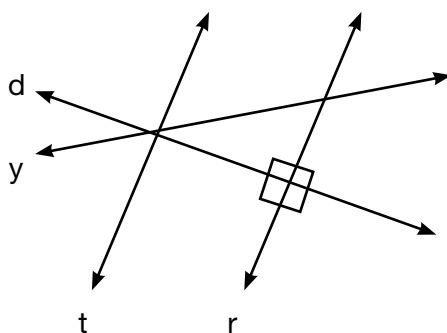

1. Is line d a transversal? Why or why not?

2. Is line  $y$  a transversal? Why or why not?

\_\_\_\_\_

3. Is line  $t$  a transversal? Why or why not?

\_\_\_\_\_

4. Is line  $r$  a transversal? Why or why not?

\_\_\_\_\_

State whether the following statements are true or false. \_\_\_\_\_

5. Perpendicular lines always form multiple right angles. \_\_\_\_\_

6. The symbol “ ” means parallel. \_\_\_\_\_

7. Transversals must always be parallel. \_\_\_\_\_

8. Perpendicular lines can be formed by intersecting or nonintersecting lines.

Complete the sentences with the correct word: always, sometimes, or never.

9. Parallel lines are \_\_\_\_\_ the same distance apart.

10. Parallel lines \_\_\_\_\_ intersect.

11. Parallel lines are \_\_\_\_\_ cut by a transversal.

12. Parallel lines that are cut by a transversal \_\_\_\_\_ form right angles.

### Part Two

In the following figure,  $m \parallel n$  and  $s \parallel t$ . For questions 1-6, (a) state the special name for each pair of angles then (b) tell if the angles are congruent or supplementary.

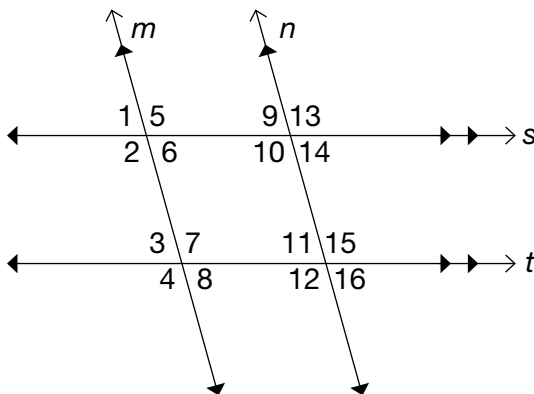

1.  $\angle 2$  and  $\angle 10$

a. \_\_\_\_\_ b. \_\_\_\_\_

2.  $\angle 6$  and  $\angle 7$

a. \_\_\_\_\_ b. \_\_\_\_\_

3.  $\angle 13$  and  $\angle 15$

a. \_\_\_\_\_ b. \_\_\_\_\_

4.  $\angle 11$  and  $\angle 14$

a. \_\_\_\_\_ b. \_\_\_\_\_

5. List all angles that are equal to  $\angle 1$ .

6. List all angles that are supplementary to  $\angle 11$ .

For questions 7-10, use the measure of the given angle to find the missing angle. State the special name for the angles. Use the diagram above.

7.  $m\angle 2 = 100^\circ$ , so  $m\angle 7 =$  \_\_\_\_\_

8.  $m\angle 8 = 71^\circ$ , so  $m\angle 12 =$  \_\_\_\_\_

9.  $m\angle 5 = 110^\circ$ , so  $m\angle 7 =$  \_\_\_\_\_

10.  $m\angle 2 = 125^\circ$ , so  $m\angle 11 =$  \_\_\_\_\_

Complete the statement for practice problems 11-16.

11. Alternate interior angles are similar to corresponding angles because

\_\_\_\_\_.

12. Alternate interior angles differ from corresponding angles because

\_\_\_\_\_.

13. Same-side interior angles are similar to alternate interior angles because

\_\_\_\_\_.

14. Same-side interior angles differ from alternate interior angles because

\_\_\_\_\_.

15. Same-side interior angles are similar to corresponding angles because

\_\_\_\_\_.

16. Same-side interior angles differ from corresponding angles because

\_\_\_\_\_.

Key for Task #6

1. Yes. D intersects t and r
2. Yes. Y intersects t, r and d
3. Yes. T intersects y and d
4. Yes. R intersects y and d
5. True
6. False
7. False
8. False
9. Always
10. Never
11. Sometimes
12. Sometimes

Part Two Key

- 1 a. corresponding angles b. congruent
- 2 a. same side interior b. supplementary
- 3 a. corresponding angles b. congruent
4. a. alternate interior b. congruent
5. Angles 6, 9, 14, 3, 8, 11, 16
6. Angles 2, 4, 5, 7, 10, 12, 13, 15
7. 100 degrees Alternate interior angles
8. 109 degrees Same side interior angles
9. 110 degrees Corresponding angles
10. 75 degrees Angles 2 and 4 are corresponding  
Angles 4 and 12 are corresponding  
Angles 12 and 11 supplementary  
Therefore angles 11 and 2 are supplementary
11. They are both congruent
12. They do not occupy the same position
13. They are all inside the parallel lines
14. Same side are supplementary while alternate interior are congruent
15. They are formed when parallel lines are cut by a transversal
16. Same side interior angles are supplementary while corresponding angles are congruent

Extension: If student groups finish early, ask students to create a word problem that requires use of what they learned today. Ask students to provide real world examples of situations where angle relationships are used to solve a problem. Another option is to ask students to identify two careers that would use lines and angle relationships and have them describe how these would be used.

### Evaluate Understanding/ Closing Activity

**PRI 3**  
**PRI 10**

When group work is complete, call on students to share their answers to “Working With Parallel lines Cut by a Transversal”.

Students should construct viable arguments and critique the reasoning of others as they discuss their results, strategies they used, and explain why their results make sense. In addition, students will reflect on mistakes and misconceptions to improve mathematical understanding.

INCLUDED IN THE STUDENT MANUAL

#### Task #7: Lesson 2 Reflection

1. Summarize what you learned in this lesson.

\_\_\_\_\_

\_\_\_\_\_

\_\_\_\_\_

\_\_\_\_\_

\_\_\_\_\_

\_\_\_\_\_

\_\_\_\_\_

\_\_\_\_\_

\_\_\_\_\_

\_\_\_\_\_

2. How is this skill helpful in the real-world? Explain.

\_\_\_\_\_

\_\_\_\_\_

\_\_\_\_\_

\_\_\_\_\_

\_\_\_\_\_

\_\_\_\_\_

\_\_\_\_\_

\_\_\_\_\_

\_\_\_\_\_

\_\_\_\_\_

### Independent Practice:

Students will complete Task #8: “Parallel Lines Summative Assignment” for homework.

INCLUDED IN THE STUDENT MANUAL

#### Task #8: Parallel Lines Summative Assignment

1. As you worked with the angle pieces, what relationships exist between the angles formed by the parallel lines cut by the transversal?

---

---

---

---

---

---

2. Describe how you can find the measure of all the angles formed when parallel lines are cut by a transversal given one angle measure.

---

---

---

---

---

---

Not for Review Copy  
Distribution

### Materials needed:

- Projector
  - Notebook paper
  - Rulers
  - Protractors
  - Dictionaries
  - Student Manual
  - Patty Paper
  - Task #3: Special Angles Intro Questions
  - Task #4: Special Angle Pairs Vocabulary
  - Task #5: Special Angle Pair Investigation
  - Task #6: Working with Parallel Lines Cut by a Transversal
  - Task #7: Reflection – Lesson 2
  - Task #8: Parallel Lines Summative Assignment
- Print and cut apart angle pieces from template that follows for students use during Task #5.



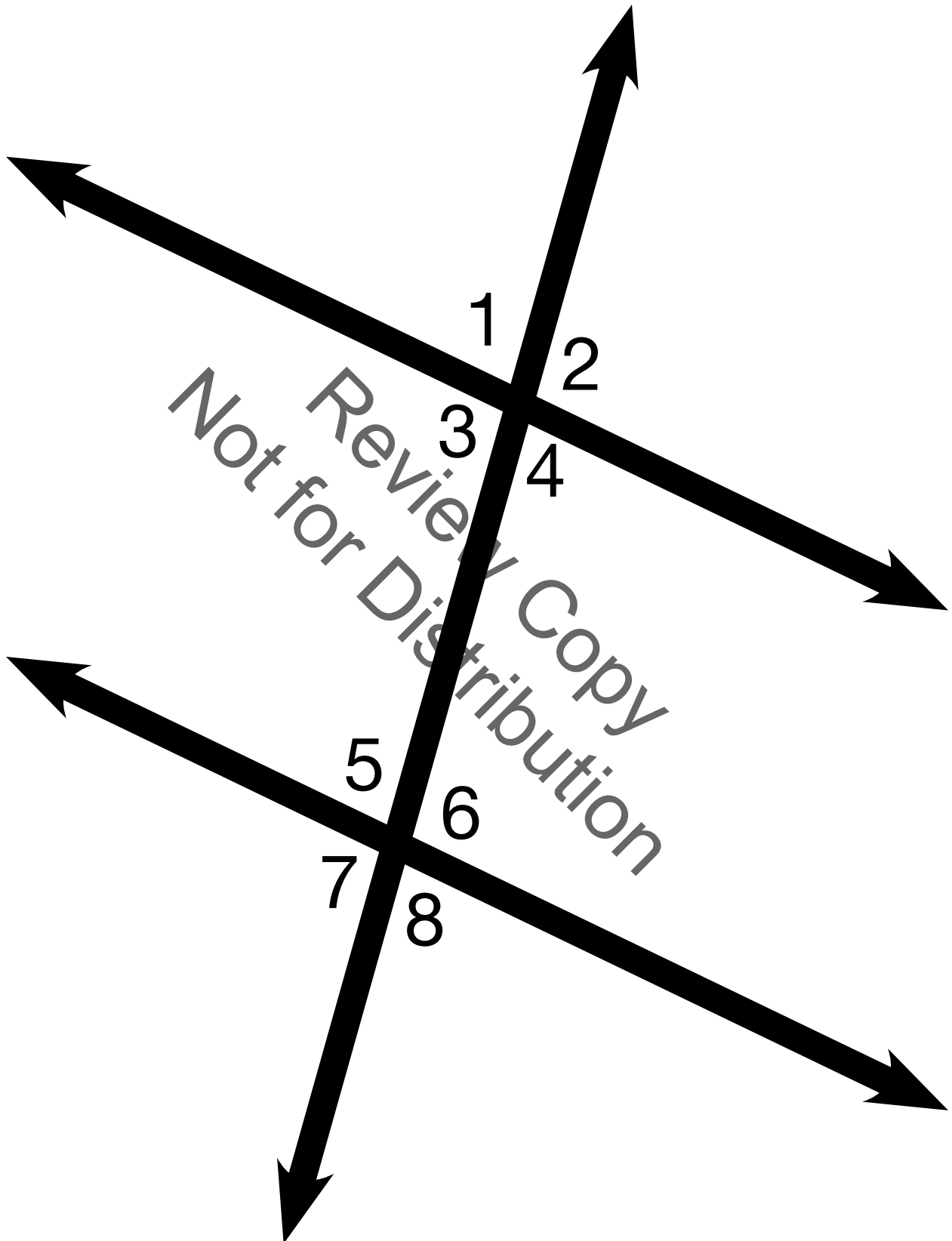

## Geometry

# Lesson 3 of 9

## Triangle Angle Sum Theorem

### Description:

Students will connect their knowledge about lines and angles to deduce the Triangle Angle Sum Theorem. They will then experiment with a GeoGebra-based computer model to investigate their findings. Students will ultimately use the Triangle Angle Sum Theorem to write and solve equations and find missing angle measures in a variety of examples.

### College- and Career-Readiness Standards Addressed:

- G.10 Use informal arguments to establish facts about the angles created when parallel lines are cut by a transversal.

### Process Readiness Indicators Emphasized:

- PRI 3: Construct viable arguments and critique the reasoning of others.
- PRI 5: Use appropriate tools strategically to support thinking and problem solving.
- PRI 8: Look for and express regularity in repeated reasoning.
- PRI 9: Demonstrate flexible use of strategies and methods while reflecting on which procedures seem to work best for specific types of problems.
- PRI 10: Reflect on mistakes and misconceptions to improve mathematical understanding.

Sequence of  
Instruction

Activities Checklist

### Engage

**Commentary for the Teacher:** We recommend grouping students by “like abilities” throughout this lesson. This will allow students to work at their own level and to be an active participant in the learning process.

Using partners, ask students to complete Task #9: Triangle Sum Proof Worksheet (informal proof). Tell students to draw from their knowledge of special angle pairs discovered in the previous lesson. Do not instruct or give answers to students at this time. This gives students an opportunity to participate in a “productive struggle.” Students will return to this activity at the end of the lesson. *(If you and your students completed Lesson 7 of Unit 2: Ratios and Proportions, students can utilize their findings to help with this proof.)*

INCLUDED IN THE STUDENT MANUAL

### Task #9: Triangle Sum Proof Worksheet

The diagram below shows  $\triangle ABC$  in which  $\overline{AC}$  is parallel to line  $\overline{BD}$ .

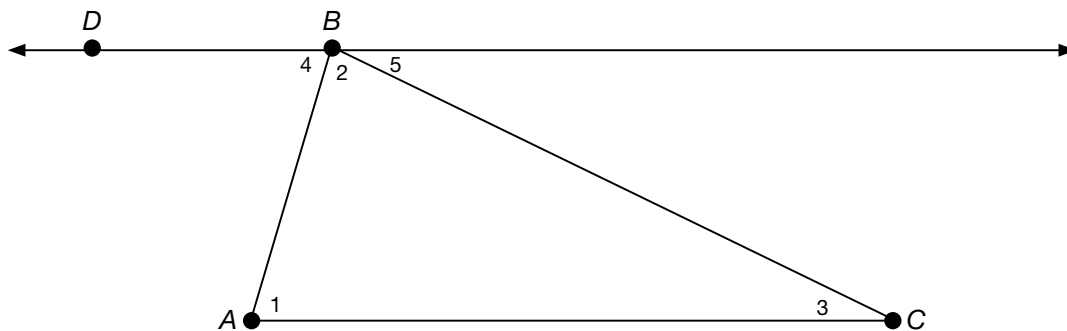

In the space below prove that the sum of the interior angles of  $\triangle ABC$  is  $180^\circ$ , that is, prove that  $m\angle 1 + m\angle 2 + m\angle 3 = 180^\circ$ .

## Explore

### PRI 5

Note: The following lesson is taken from

<http://www.cpalms.org/Public/PreviewResourceLesson/Preview/38498>

Using a GeoGebra Module, a tool that will support student thinking, students will use what they already know about alternate interior and supplementary angles. A key to supporting success of this lesson is to allow students to find the words that describe the angle relationship and support the writing of a proof.

<http://tube.geogebra.org/student/m80592>

**Commentary for the Teacher:** If students do not have 1to1 digital devices, teachers can display this module using a projector and allow student volunteers to interact with the module.

Students will find Task #10 in the student manual: Triangle Sum Proof Worksheet.

INCLUDED IN THE STUDENT MANUAL

### Task #10: Triangle Sum Proof Worksheet

1. Move the slider around until the two transversals are where you would like them.
2. In this diagram, we are using transversals and parallel lines to construct a triangle. Do you see it? When you are ready, click “show triangle.”
3. There are five angles, labeled as angle 1, 2, 3, 4, and 5. What do you know must be true about angles 1, 2, and 3?

Explain.

Move the slider. Does this still hold true for angles 1, 2, and 3?

Explain.

4. How are angles 4 and 5 related to angles 1 and 3?

Explain.

5. Check your thinking in the previous questions by clicking “show angles.”
6. What appears to be the sum of the interior angles of a triangle?

How can we use the angles given in this module to argue or prove this?

7. Move the slider. Do your discoveries still hold true?

**Commentary for the Teacher:** Use of a calculator would be recommended in the initial stage of the lesson so that the focus would shift from the calculations to mastery of the concept.

## Explanation

### PRI 8

Using paper, straight edges, and scissors, students will draw and cut out triangles of various sizes and shapes. Following the teacher’s lead on overhead or document camera with projector, have students label the triangle’s vertices A, B, and C. Fold vertex B so that it intersects with segment AC (creating a parallel line to AC). Next have students fold in Vertex A and Vertex C to coincide at Vertex B. Ask students for their observations. Does this prove their discovery in the Explore activity? Key observation:

The triangle's 3 interior angles add up to be 180 Degrees (or form a straight angle or straight line).

*Common misconception: A rectangle and/or square has been created.*

**Remediation:** Students who have difficulty with manual dexterity and struggle with manipulating and folding paper could, instead of folding, tear off the vertices of the triangle and then position the 3 angles adjacent to one another to form a line.

Use the following link, <http://tube.geogebra.org/student/m28392>, to demonstrate the Triangle Angle Sum Theorem. Through repeated reasoning and demonstrations, students will see that the theorem holds true for acute, obtuse, and right triangles.

Moving both sliders to 180 degrees will demonstrate why the theorem holds true for all types of triangles.

**Practice Together / in Small Groups / Individually**

PRI 3  
PRI 9

With small groups, students complete Task #11: Finding Interior Angles of Triangles found in their Student Manual.

INCLUDED IN THE STUDENT MANUAL

**Task #11: Finding Interior Angles of Triangles**

Example A:  $m \angle 1 =$  \_\_\_\_\_

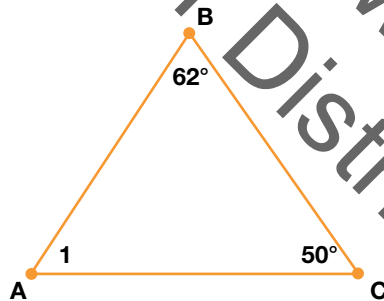

Example B:  $m \angle 2 =$  \_\_\_\_\_

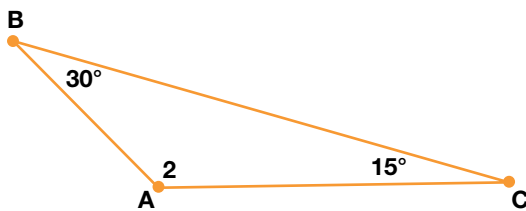

Example C:  $m \angle B =$  \_\_\_\_\_,  $m \angle C =$  \_\_\_\_\_

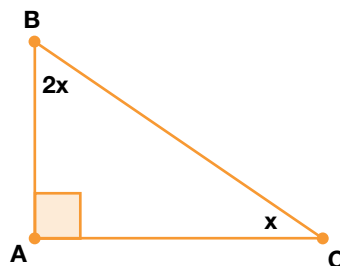

Example D:  $m \angle 4 =$  \_\_\_\_\_,  $m \angle 5 =$  \_\_\_\_\_

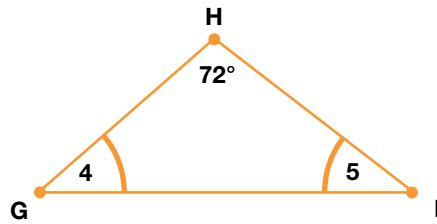

Example E:  
 $m \angle BAC =$  \_\_\_\_\_,  $m \angle BCA =$  \_\_\_\_\_,  $m \angle ABC =$  \_\_\_\_\_

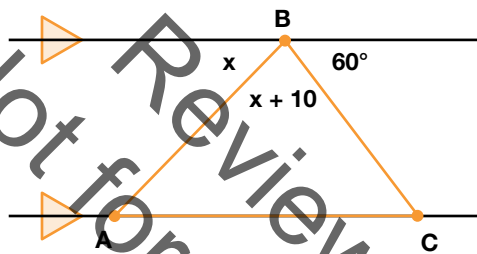

Example F:  $m \angle 9 =$  \_\_\_\_\_,  $m \angle 10 =$  \_\_\_\_\_

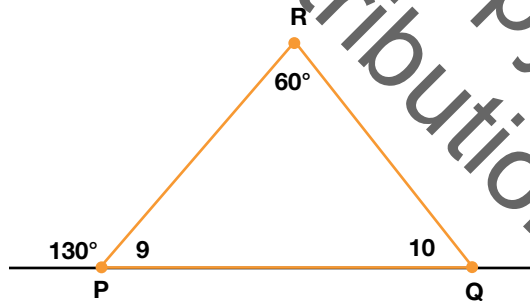

Solutions:

Example A:  $m \angle 1 = 68^\circ$

Example B:  $m \angle 2 = 135^\circ$

Example C:  $m \angle B = 60^\circ$ ,  $m \angle C = 30^\circ$

Example D:  $m \angle 4 = 54^\circ$ ,  $m \angle 5 = 54^\circ$

Example E:  $m \angle BAC = 55^\circ$ ,  $m \angle BCA = 60^\circ$ ,  $m \angle ABC = 65^\circ$

Example F:  $m \angle 9 = 50^\circ$ ,  $m \angle 10 = 70^\circ$

Group members should compare, explain and defend group answers to share which procedures work best with specific problems. Discuss as a class once groups have completed the assignment.

**Extension:** Advanced students can investigate triangle interior angles further by calculating the interior angles of wellknown structures (i.e. the Transamerica Pyramid Building in San Francisco, CA, or the pyramids in Egypt) via a webquest.

### Evaluate Understanding/ Closing Activity

#### PRI 10

Direct students back to Task #9 “Triangle Sum Proof Worksheet” in the Student Manual (Explore Activity). Ask students to reexamine their previous responses and make changes based on their new knowledge. Discuss as a class.

INCLUDED IN THE STUDENT MANUAL

#### Task #12: Lesson 3 Reflection

1. Summarize what you learned in this lesson.

Not for Review Copy  
Not for Distribution

---

---

---

---

---

---

---

---

---

---

2. How is this skill helpful in the real-world? Explain.

---

---

---

---

---

---

---

---

---

---

3. To reinforce writing skills, students will write a paragraph consisting of 5-7 sentences that includes the following information:
- An introductory sentence
  - A sentence stating the Triangle Angle Sum Theorem (The sum of the measures of the interior angles of any triangle is 180.)
  - One or two sentences that summarize student's findings in the Geogebra Activity relating special angles and the Triangle Angle Sum Theorem. (*students should describe how they utilized special angle pairs to discover the Triangle Angle Sum Theorem*)
  - One or two sentences that explain how the paper folding model exhibits the Triangle Angle Sum Theorem. (*students should describe how the angles aligned to form a straight line or 180 degrees*)
  - A conclusion. (A sentence that should restate the main idea or introductory sentence.)

**Resources/Instructional Materials Needed:**

<http://tube.geogebra.org/student/m80592> <http://tube.geogebra.org/student/m28392>  
<http://betterlesson.com/lesson/572745/trianglesumtheoremproof>

**Materials needed:**

Projector  
Paper  
Straight edge  
Scissors  
Task #9: Triangle Sum Proof Worksheet  
Task #10: GeoGebra Module Directions  
Task #11: Finding Interior Angles of Triangles



## Geometry

# Lesson 4 of 9

## Quadrilaterals

### Description:

---

The discussion of geometric figures in this unit has been limited to lines and triangles. In this lesson, students learn to classify quadrilaterals, including trapezoids, with a focus on different types of parallelograms. They learn the relationships among rectangles, squares, and rhombuses as different types of parallelograms. Students will then use these properties to solve a “murder mystery” involving 12 quadrilateral suspects.

### College- and Career-Readiness Standards Addressed:

---

- G.1 Draw and describe geometrical figures and describe the relationships between them.

### Process Readiness Indicators Emphasized:

---

- PRI 3: Construct viable arguments and critique the reasoning of others.
- PRI 5: Use appropriate tools strategically to support thinking and problem solving.
- PRI 10: Reflect on mistakes and misconceptions to improve mathematical understanding.

Sequence of  
Instruction

Activities Checklist

### Engage

---

**PRI 10**

▶ **Commentary** *for the Teacher:* Print out one copy per group of Task #13: *Parallelogram Properties Sort* on colored paper.

INCLUDED IN THE STUDENT MANUAL

### Task #13: Parallelogram Properties Sort

Four right angles

Four right angles

Both pairs of opposite sides are parallel

Both pairs of opposite sides are parallel

Both pairs of opposite sides are parallel

Both pairs of opposite sides are parallel

Diagonals are congruent

Diagonals are congruent

Opposite sides are congruent

Opposite sides are congruent

Opposite sides are congruent

Opposite sides are congruent

Diagonals bisect a pair of opposite angles

Diagonals bisect a pair of opposite angles

Opposite angles are congruent

These quadrilateral properties are for parallelograms, squares, rhombi, and rectangles. They are all jumbled up. Cut them out, along with the shape names, and sort them into four piles. There is EXACTLY the amount of properties you need.

**P  
A  
R  
A  
L  
L  
E  
L  
O  
G  
R  
A  
M**

**R  
E  
C  
T  
A  
N  
G  
L  
E**



Opposite angles are congruent

Opposite angles are congruent

Opposite angles are congruent

Diagonals are perpendicular

Diagonals are perpendicular

Consecutive angles are supplementary

Consecutive angles are supplementary

Consecutive angles are supplementary

Consecutive angles are supplementary

Four congruent sides

Four congruent sides

Diagonals bisect each other

Diagonals bisect each other

Diagonals bisect each other

Diagonals bisect each other

REMEMBER  
SQUARE

Not for Review Copy  
Distribution

Begin by asking students to use whiteboards or scrap paper and draw a non-example and an example of a parallelogram. Review the properties of a parallelogram. Break students into groups of four. Pass out the “Parallelogram Sort”.

Students will need rulers and protractors. Instruct students to first cut the properties apart and then sort them into four groups. In addition, students will cut out the words parallelogram, rhombus, square, and rectangle to help start their sorting.

Students should use appropriate tools strategically (the guide, rulers, and protractors) to support thinking and to determine which properties apply to which shapes. For the properties that are repeated four times, students should realize that one goes into each pile. Suggest for students to draw on the shapes (i.e. the diagonals) to get accurate measurements. Circulate and monitor students’ progress.

**Commentary for the Teacher:** Students could also use patty paper to check for congruence.

## Explanation

### PRI 10

After each team has agreed on the properties for each shape, bring the class back together. Direct students to Task #14: Parallelogram Properties Sort Checklist in the Student Manual.

INCLUDED IN THE STUDENT MANUAL

#### Task #14: Parallelogram Properties Sort Checklist

Property	Rectangle	Rhombus	Square	All Parallelograms
<b>The Sides</b>				
Both pairs of opposite sides are parallel.				
Opposite sides are congruent.				
All sides are congruent.				
<b>The Angles</b>				
Sum of the angles is $360^\circ$ .				
Opposite angles are congruent.				
All four angles are right angles.				
Consecutive angles are supplementary.				
All four angles are right angles.				
<b>The Diagonals</b>				
Diagonals bisect each other.				
Diagonals are congruent.				
Diagonals are perpendicular.				
Diagonals bisect opposite angles.				

As a class, share students' findings and complete the checklist. Students will construct viable arguments and critique the reasoning of others, reflect on mistakes and misconceptions to improve mathematical understanding, and discuss their strategic use of tools. ("What tools did you use to verify this property?")

### Practice Together / in Small Groups / Individually

**Commentary for the Teacher:** Use informal observations from the previous activity to group students by like abilities for this activity. This will allow students to work at their own level and to be an active participant in the learning process.

To begin the activity, it is fun to play a Horror Sounds CD while a student volunteer reads the story. Provide groups with a "murder mystery" sheet ("Geometrica Fights Back") with descriptions of each "suspect" and a "lineup" of twelve suspects ("Suspect Figures"). The students must decide which suspect(s) from the lineup meets the description. The "guilty" quadrilateral will be discovered at the end of the activity. The following activities come from: [https://alex.state.al.us/lesson\\_view.php?id=3009](https://alex.state.al.us/lesson_view.php?id=3009)

INCLUDED IN THE STUDENT MANUAL

#### Task #15: "Geometrica Fights Back" and "Suspect Figures"

##### Geometrica Fights Back

##### Mystery of the Guilty Quadrilateral

Once upon a time long, long ago in a far, far away land known as Geometrica there occurred an unspeakable crime. On a dark and dreary night as the Circular family lay sleeping in their soft, round beds and dreaming of their favorite dessert, pi, a violent criminal murdered them. Their neighbor, Mrs. Equi Angular said that she and her husband, Mr. Tri Angular, heard the awful blood curdling screams. So, they sprang from their bed to see what was the matter, and what to their wandering eyes did appear (not eight tiny reindeer) but a strange four-sided figure leaping from the Circular's upstairs window. Well, the Angulars gave a description of the terrible beast and so did many other Geometrica residents. However, to this day, the mystery remains. Therefore, Detective Pentagonal Walsh of Geometrica's Most Wanted has asked for your assistance in solving this crime. Below you will find descriptions that tipsters have given the authorities. Your job is to list the suspects from your line-up of twelve figures (numbered shapes) that meet each set of criteria.

1. Four-sided figure and convex

Suspects: \_\_\_\_\_

2. Four-sided figure with two sets of parallel sides

Suspects: \_\_\_\_\_

3. Four-sided figure with four right angles

Suspects: \_\_\_\_\_

4. Four-sided figure with all sides equal

Suspects: \_\_\_\_\_

5. Four-sided figure whose diagonals bisect each other

Suspects: \_\_\_\_\_

6. Four-sided figure whose opposite angles are congruent  
Suspects: \_\_\_\_\_
7. Four-sided figure with only one set of parallel sides  
Suspects: \_\_\_\_\_
8. Four-sided figure whose consecutive angles are supplementary  
Suspects: \_\_\_\_\_
9. Four-sided figure whose diagonals are congruent  
Suspects: \_\_\_\_\_
10. Four-sided figure whose diagonals are perpendicular  
Suspects: \_\_\_\_\_
11. Four-sided figure with all equal sides and four right angles  
Suspects: \_\_\_\_\_
12. Four-sided figure with all equal sides and perpendicular diagonals  
Suspects: \_\_\_\_\_
13. Four-sided figure with all equal sides and congruent diagonals  
Suspects: \_\_\_\_\_
14. Four-sided figure whose legs are congruent  
Suspects: \_\_\_\_\_
15. Four-sided figure whose opposite sides are congruent  
Suspects: \_\_\_\_\_
16. Four-sided figure and concave  
Suspects: \_\_\_\_\_
17. Four-sided figure with exactly one pair of opposite angles that are congruent  
Suspects: \_\_\_\_\_
18. Four-sided figure with no parallel sides  
Suspects: \_\_\_\_\_
19. Four-sided figure with two right angles  
Suspects: \_\_\_\_\_
20. Four-sided figure with no equal sides (scalene)  
Suspects: \_\_\_\_\_
21. Suspect might be a parallelogram.  
Suspects: \_\_\_\_\_
22. Suspect might be a trapezoid.  
Suspects: \_\_\_\_\_

Who killed the Circulars? The guilty quad is the one whose number appears the most in the above list. Suspect number \_\_\_\_\_ is the criminal.

## Evaluate Understanding / Closing Activity

**PRI 3**

As a whole class, discuss groups “guilty” quadrilateral. Students will construct viable arguments and critique the reasoning of others.

INCLUDED IN THE STUDENT MANUAL

### Task #16: Lesson 4 Reflection

1. Summarize what you learned in this lesson.

---

---

---

---

---

---

---

---

---

---

2. How is this skill helpful in the real-world? Explain.

---

---

---

---

---

---

---

---

---

---

Review Copy  
Not for Distribution

## Independent Practice

### Task #17: Always, Sometimes, Never

INCLUDED IN THE STUDENT MANUAL

#### Task #17: Always, Sometimes, Never

For each of the following, reply with always, sometimes, or never.

1. The diagonals of a parallelogram are \_\_\_\_\_ equal.
2. Both pairs of opposite angles of a kite are \_\_\_\_\_ equal.
3. The diagonals of a rectangle are \_\_\_\_\_ perpendicular.
4. The diagonals of a rhombus are \_\_\_\_\_ equal.
5. The diagonals of a trapezoid are \_\_\_\_\_ equal.
6. Trapezoids are \_\_\_\_\_ kites.
7. Two pairs of consecutive sides of a rhombus are \_\_\_\_\_ equal.
8. The diagonals of a trapezoid are \_\_\_\_\_ perpendicular.
9. Both pairs of opposite angles of a rectangle are \_\_\_\_\_ bisected.
10. The angles of a rhombus are \_\_\_\_\_ right angles.
11. The diagonals of a rhombus \_\_\_\_\_ bisect each-other.
12. Kites \_\_\_\_\_ have one pair of congruent opposite angles.
13. Both pairs of opposite angles of a kite are \_\_\_\_\_ bisected by diagonals.
14. Trapezoids are \_\_\_\_\_ isosceles.
15. Parallelograms are \_\_\_\_\_ squares.

Answers:

- |       |       |       |       |       |
|-------|-------|-------|-------|-------|
| 1. S  | 2. N  | 3. S  | 4. S  | 5. S  |
| 6. N  | 7. A  | 8. N  | 9. S  | 10. S |
| 11. A | 12. N | 13. S | 14. S | 15. S |



### Resources/Instructional Materials Needed:

---

<http://betterlesson.com/community/lesson/28658/quadrilateralinvestigation>  
[http://alex.state.al.us/lesson\\_view.php?id=3009](http://alex.state.al.us/lesson_view.php?id=3009)  
[www.KaganOnline.com](http://www.KaganOnline.com)

### Materials needed:

---

Protractor  
Ruler  
Task #13: Parallelogram Properties Sort  
Task #14: Parallelogram Properties Sort Checklist  
Task #15: Geometrica Fights Back  
Task #16: Reflection on Lesson 4  
Task #17: Quadrilaterals Review – Sometime, Never, Always

Not for Review Copy  
Not for Distribution

## Geometry

# Lesson 5 of 9

## FAL - Describing and Defining Quadrilaterals

### Description:

---

This lesson is intended to help you assess how well students are able to:

- Name and classify quadrilaterals according to their properties.
- Identify the minimal information required to define a quadrilateral.
- Sketch quadrilaterals with given conditions.

### College- and Career-Readiness Standards Addressed:

---

- G.2 Draw, construct, and describe geometrical figures and describe the relationships between them.

### Process Readiness Indicators Emphasized:

---

- PRI 3: Describe and justify mathematical understandings by constructing viable arguments, critiquing the reasoning of others and engaging in meaningful mathematical discourse.
- PRI 6: Attend to precision.
- PRI 7: Look for and make use of patterns and structure.
- PRI 8: Look for and express regularity in repeated reasoning.
- PRI 9: Demonstrate flexible use of strategies and methods while reflecting on which procedures seem to work best for specific types of problems.
- PRI 10: Reflect on mistakes and misconceptions to improve mathematical understanding.

The following *Formative Assessment Lesson* is a classroom-ready lesson included to help teachers assess and improve students' understanding of mathematical concepts and skills and their ability to use the mathematical process readiness indicators critical for college readiness.

Research has shown that formative assessment, as embodied in the following lesson, is a powerful way to improve student learning and performance. This approach first allows students to demonstrate their prior understandings and abilities in employing the mathematical processes, and then resolve their own difficulties and misconceptions through structured discussion. This results in more secure long-term learning, reducing the need for re-teaching that otherwise takes so much classroom time.

Many often ask, why don't students just remember the procedures they have been taught and practiced? The fact is, that approach works fine in the short term but, as every teacher knows, if procedural knowledge is not underpinned by conceptual understanding, students will quickly forget "how to do it."

Read more about the *Formative Assessment Lesson* rationale, structure, and philosophy using the *Brief Guide for Teachers and Administrators* that can be found at <http://map.mathshell.org/materials/index.php>.

---

## CONCEPT DEVELOPMENT

---

Mathematics Assessment Project  
**CLASSROOM CHALLENGES**  
A Formative Assessment Lesson

# Describing and Defining Quadrilaterals

Mathematics Assessment Resource Service  
University of Nottingham & UC Berkeley

For more details, visit: <http://map.mathshell.org>  
© 2015 MARS, Shell Center, University of Nottingham  
May be reproduced, unmodified, for non-commercial purposes under the Creative Commons license  
detailed at <http://creativecommons.org/licenses/by-nc-nd/3.0/> - all other rights reserved

## BEFORE THE LESSON

### Assessment task: *Classifying Quadrilaterals* (15 minutes)

Have the students complete this task, in class or for homework, a few days before the formative assessment lesson. This will give you an opportunity to assess the work and to find out the kinds of difficulties students have with it. You should then be able to target your help more effectively in the subsequent lesson.

Introduce the task briefly and help the class to understand what they are being asked to do.

*This task is all about quadrilaterals. What are we referring to when we talk about a quadrilateral?*

*Different quadrilaterals have different properties and we can use these to help us to identify and classify a shape.*

*What do we mean by mathematical 'properties'? [Features of the shape.]*

Before giving each student a copy of *Classifying Quadrilaterals*, you may want to display Slide P-1 for students to refer to when working on the assessment.

Note: Although there may be other definitions for some shapes, for this lesson, the definitions on the slide will be used.

You may also want to check that your students understand the terms 'bisect' and 'diagonal'.

Once students have a copy of the task:

*Read through the questions and try to answer them as carefully as you can. Give reasons and explain your answers fully.*

It is important that, as far as possible, students are allowed to answer the questions without your assistance.

Students should not worry too much if they cannot understand or do everything, because in the next lesson they will engage in a similar task, which should help them. Explain to students that by the end of the next lesson, they should expect to be able to answer questions like these confidently. This is their goal.

Shape Definitions	
<b>Parallelogram:</b>	Quadrilateral with two pairs of parallel sides.
<b>Rectangle:</b>	Quadrilateral where all four angles are right angles.
<b>Square:</b>	Quadrilateral where all four sides are of equal length and all four angles are right angles.
<b>Rhombus:</b>	Quadrilateral where all four sides are of equal length.
<b>Kite:</b>	Quadrilateral where two pairs of adjacent sides are of equal length.
<b>Trapezoid:</b>	Quadrilateral where at least one pair of opposite sides are parallel.

Classifying Quadrilaterals	
1. Complete the boxes below with the word 'All', 'Some' or 'No' to make the statements about quadrilaterals correct, giving reasons for your word choice. Your reasons can include diagrams.	
a. <input type="checkbox"/> rectangles are squares.	Reason for your choice of word:
.....	
.....	
b. <input type="checkbox"/> rhombuses are parallelograms.	Reason for your choice of word:
.....	
.....	
c. <input type="checkbox"/> trapezoids are rectangles.	Reason for your choice of word:
.....	
.....	
d. <input type="checkbox"/> kites are rhombuses.	Reason for your choice of word:
.....	
.....	

2. Which of the following quadrilaterals must have at least one pair of parallel sides? Circle all that apply.	
<input type="checkbox"/> Rectangle <input type="checkbox"/> Square <input type="checkbox"/> Trapezoid <input type="checkbox"/> Parallelogram <input type="checkbox"/> Kite <input type="checkbox"/> Rhombus	
Explain your answer:	
.....	
.....	
3. In which of the following quadrilaterals do the diagonals bisect each other? Circle all that apply.	
<input type="checkbox"/> Rectangle <input type="checkbox"/> Square <input type="checkbox"/> Trapezoid <input type="checkbox"/> Parallelogram <input type="checkbox"/> Kite <input type="checkbox"/> Rhombus	
Explain your answer:	
.....	

### Assessing students' responses

Collect students' responses to the task. Make some notes on what their work reveals about their current levels of understanding and their different problem solving approaches.

We suggest that you do not score students' work. The research shows that this will be counterproductive, as it will encourage students to compare their scores and distract their attention from what they can do to improve their mathematics.

Instead, help students to make further progress by summarizing their difficulties as a series of questions. Some suggestions for these are given in the *Common issues* table on the next page. These have been drawn from common difficulties observed in trials of this unit.

We suggest you make a list of your own questions, based on your students' work. We recommend you either:

- write one or two questions on each student's work, or
- give each student a printed version of your list of questions and highlight the questions for each individual student.

If you do not have time to do this, you could select a few questions that will be of help to the majority of students and write these questions on the board when you return the work to the students in the follow-up lesson.

<b>Common issues:</b>	<b>Suggested questions and prompts:</b>
<p><b>Understands different types of quadrilaterals as being distinct shapes rather than some quadrilaterals being subsets of others</b></p> <p>For example: The student states that ‘no’ rectangles are squares. (Q1a)</p>	<ul style="list-style-type: none"> <li>• What properties does a rectangle/square have?</li> <li>• Does a rectangle/square have all the properties of a square/rectangle?</li> <li>• Is it possible that one type of quadrilateral could be a special kind of a different quadrilateral? How could you tell from the properties if this was the case?</li> </ul>
<p><b>Assumes that the opposite sides of a rhombus are not parallel</b></p> <p>For example: The student states that ‘no’ rhombuses are parallelograms. (Q1b)</p> <p>Or: The student states that ‘some’ kites are rhombuses. (Q1d)</p> <p>Or: Fails to circle ‘rhombus’ as having at least one pair of parallel sides. (Q2)</p>	<ul style="list-style-type: none"> <li>• What do you know about the angles in a rhombus?</li> </ul>
<p><b>Assumes that a kite contains parallel sides</b></p> <p>For example: The student circles ‘kite’ as having at least one pair of parallel sides. (Q2)</p>	<ul style="list-style-type: none"> <li>• Does a kite have congruent sides?</li> <li>• Which sides in a kite are congruent?</li> </ul>
<p><b>Assumes diagonals that bisect must do so at 90°</b></p> <p>For example: The student circles just the square. (Q3)</p>	<ul style="list-style-type: none"> <li>• What does it mean for diagonals to bisect each other?</li> </ul>
<p><b>Assumes that the diagonals in an isosceles trapezoid bisect each other</b></p> <p>For example: The student provides an explanation that the diagonals of isosceles trapezoids bisect each other whereas non-isosceles trapezoids contain non-bisecting diagonals. (Q3)</p>	<ul style="list-style-type: none"> <li>• In what way is an isosceles trapezoid different to a non-isosceles trapezoid?</li> <li>• Draw in the diagonals of an isosceles trapezoid. What properties would the two triangles that are formed have if the diagonals were bisecting?</li> </ul>
<p><b>Provides little or no explanation</b></p> <p>For example: The student gives no reason for their choice of word (Q1) and/or fails to explain their answers. (Q2 &amp; Q3)</p>	<ul style="list-style-type: none"> <li>• Which properties of (rectangles) do (trapezoids) not satisfy?</li> <li>• Can you convince me that a (rhombus) satisfies all the properties of a (parallelogram)?</li> <li>• What additional properties does a (square) have?</li> </ul>

## SUGGESTED LESSON OUTLINE

### Whole-class interactive introduction (20 minutes)

Give each student a mini-whiteboard, pen, and eraser.

Remind the class of the assessment task they have already attempted.

*Recall what we were working on previously. What was the task about?*

*What do we mean by the 'properties' of a quadrilateral? [The mathematical features that the shape possesses.]*

*Let's now think about a specific quadrilateral.*

Display Slide P-2 of the projector resource showing a square.

*Spend a few minutes, on your own, writing on your whiteboard as many properties of a square as you can. Try to be as detailed as possible.*

Once students have had a chance to identify a list of properties, list the students' ideas on the board. As you do this, encourage students to express the properties using correct mathematical language:

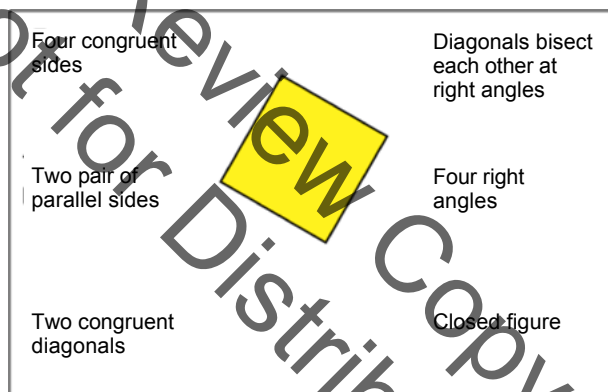

If students do not mention all of the features shown above, draw their attention to them and to the language needed to describe them, as they will need to understand this vocabulary for the rest of the lesson.

*What do we mean by the word 'congruent'?*

*What do we mean by the word 'parallel'?*

*What is a 'diagonal'?*

*What does 'bisect' mean?*

*What does 'bisect at right angles' mean?*

It may be helpful when collating ideas about the properties of a square to discuss ways of showing some of these properties on the diagram, for example:

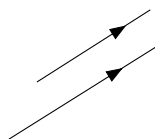

These lines are parallel

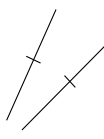

These lines are congruent

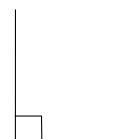

This angle is  $90^\circ$

When a range of properties have been identified, ask the following:

*Remember that for this lesson we are talking about quadrilaterals only.*

*Does this property [e.g. two equal diagonals] by itself define a square?  
If not, what other quadrilaterals have this property? [E.g. rectangle.]*

*Can you identify two properties that together define a square?  
Can you find another pair?*

*What else do you need to know in order to draw the square?  
[E.g. four right angles and four congruent sides.]*

*Can you identify a pair of properties that won't necessarily define a square?  
What other quadrilaterals could these properties be defining?  
[E.g. 'diagonals meet at 90°' and 'four congruent sides' could be describing a rhombus.]*

It may be appropriate to extend this questioning further to include, for example, more than two properties. However, being able to identify properties that define a square will depend on the original list generated by the class.

### Individual work, then collaborative work: *Sketching Quadrilaterals* (40 minutes)

Organize students into pairs and give each group of students the six sets of *Properties* cards, cut into strips. Ask students to work individually to start with. Introduce the activity by showing and explaining to students Slide R-3 of the projector resource:

#### Working individually

1. Each strip of 5 properties describes a quadrilateral. Each person should select just one set.
2. For this set, draw the quadrilateral described by the 5 properties on your mini-whiteboard. Name the quadrilateral you have drawn. Label the sides and angles.
3. Now select the **smallest** number of cards you need in order to define the shape and size of the quadrilateral.
4. Be prepared to explain to your partner how you know that the shape you have sketched is correct and why you only need these cards to define it.

When most students have at least one card set completed, ask students to work in pairs. Give each pair some scissors, a glue stick and six copies of *Sketching Quadrilaterals*. Explain Slide P-4 of the projector resource:

#### Sharing Work

1. Take turns to share your drawing and explanation with your partner. Ask questions if you do not understand an explanation.
2. Make sure you both agree and can explain:
  - why your chosen cards define the shape and size of your quadrilateral,
  - why this is the smallest number of cards needed.
3. Complete the *Sketching Quadrilaterals* sheet, gluing down the cards in the agreed order.

Once students have agreed upon and completed the cards they worked on individually, they need to work collaboratively on the remaining *Properties* cards.



Display Slide P-5 of the projector resource and explain how students are to work together:

Working Collaboratively	
1.	Work together to complete the remaining property sets.
2.	Take turns to select cards, justifying your choice.
3.	If there is disagreement, explain your reasoning.
4.	When you both agree, complete the <i>Sketching Quadrilaterals</i> sheet before moving on to the next set of properties.

You have two tasks during the group work: to make a note of student approaches to the task and to support students working as a group.

**Make a note of student approaches to the task**

Listen and watch students carefully. In particular, notice how students make a start on the task, where they get stuck and how they overcome any difficulties.

Do students sort the set of property cards in any way before they start to sketch the quadrilateral? If so, how? What do they focus on first? Are there any cards that they consider to be irrelevant or do they use the information on these cards to check that the quadrilateral they have drawn is correct? What do they do when a property card that they haven't referred to when drawing their sketch contradicts what they have drawn? To make the minimal set of property cards needed to define the shape, do they eliminate cards from the original set or do they build up the minimal set?

**Support students working as a group**

As students work on the task support them in working together. Encourage them to take turns and if you notice that one partner is doing all the sketching or that they are not working collaboratively on the task, ask students in the group to explain a sketch drawn by someone else in the group.

Encourage students to clearly explain their choice of cards. Some shapes can be defined using more than one combination of cards. If this is the case, encourage students to make a note of the other possible card combination(s) somewhere on their sheet.

Try to avoid identifying the information students need to complete a sketch. If students are struggling to get started, encourage them to think about what quadrilaterals they know and their properties. This may help them recognize which properties these quadrilaterals share and which make them distinct shapes.

Check that students have completed each sheet before moving on to the next set of properties.

*How did you figure out the minimal set of property cards to define the shape?*

*Is there a different set of property cards that could also define the shape?*

*If I removed this property card from your minimal set of shapes, what shapes can now be defined?*

*Is it possible to figure out all the angles and lengths for the quadrilateral? [Not for Shape E and F. Students would need to draw the shapes accurately or use trigonometry!]*

It is not essential that students work on all six property sets, but rather that they are able to develop good explanations.

If students do successfully complete all six sketches, encourage them to produce an accurate drawing of each of the six quadrilaterals using a ruler and protractor and/or compasses.

#### **Extending the lesson over two days**

If your lessons are shorter, you may wish to stop students part-way through the collaborative work and continue with this in the next lesson. If this is the case, at the end of the first lesson, make sure that all of the *Properties* cards that have been agreed upon have been stuck down. Then, at the start of the second lesson, give students time to familiarize themselves with their work and complete any sets of properties they have yet to work on. It is not essential that all students complete all six property sets, but most groups should have at least two or three sets completed before moving on to discuss them as a whole-class.

#### **Whole-class discussion (20 minutes)**

The aim of this discussion is to explore the different combinations of property cards used by students when completing their sketches. There may not be time to discuss all six quadrilaterals but aim to discuss at least two or three. Use your knowledge of the students' group work to call on a wide range of students for contributions.

*Charlie, what quadrilateral did your group draw for property card set C?*

*Did any group sketch a different quadrilateral?*

*Charlie come and sketch the shape your group drew for property card set C on the board.*

If students have sketched a different quadrilateral for a particular property card set or labeled the sketch differently, ask them to re-produce their sketch on the board as well so that the sketches can be compared. Alternatively a document reader may be used, if available, to enable the class to compare sketches.

*Charlie, which property cards did your group use to define this quadrilateral?*

*Has Charlie's group used the least possible number of cards?*

*Let's test his answer.*

*If we remove this property card, what else could the shape be?*

*Now let's remove this one instead...*

*Did any group use a different minimal set of cards to define the quadrilateral?*

Once the completion of sketches for a few of the quadrilaterals has been discussed, explore further the different strategies used when completing the sketches.

*Which quadrilaterals were the easiest to sketch? Why was this?*

*Did you look for a particular type of property when starting to sketch the quadrilateral or did it vary from shape to shape?*

*Were the property cards that didn't get selected for the minimal set used to check the sketch and/or quadrilateral type?*

*Is it possible to draw any of these shapes without knowing all the measurements? [Yes, Shapes E and F. Trigonometry is needed to figure out the missing angles and lengths!]*

You may want to draw on the questions in the *Common issues* table to support your own questioning. Slides P-6 to P-11 (printed on transparency film if preferred) may be used to support this discussion.

**Follow-up lesson: reviewing the assessment task (15 minutes)**

Give each student a copy of the assessment task *Classifying Quadrilaterals (revisited)* and their original solutions to the assessment task *Classifying Quadrilaterals*.

*Read through your papers from *Classifying Quadrilaterals* and the questions [on the board/written on your paper.] Answer these questions and revise your response.*

*Now look at the new task sheet, *Classifying Quadrilaterals (revisited)*. Can you use what you have learned to answer these questions?*

If students struggled with the original assessment task, you may feel it more appropriate for them to revisit *Classifying Quadrilaterals* rather than attempting *Classifying Quadrilaterals (revisited)*. If this is the case, give them another copy of the original assessment task instead.

Review Copy  
Not for Distribution

## SOLUTIONS

### Definitions:

In the solutions below we use the following definitions.

**Parallelogram:** quadrilateral with two pairs of parallel sides.

**Rectangle:** quadrilateral where all four angles are right angles.

**Square:** quadrilateral where all four sides are of equal length, and all four angles are right angles.

**Rhombus:** quadrilateral where all four sides are of equal length.

**Kite:** quadrilateral where two pairs of adjacent sides are of equal length.

**Trapezoid:** quadrilateral where at least one pair of opposite sides are parallel.

### Assessment task: *Classifying Quadrilaterals*

- 1a. **SOME** rectangles are squares. A square has all the properties of a rectangle with the additional property of four congruent sides.
- 1b. **ALL** rhombuses are parallelograms. Parallelograms have congruent and parallel opposite sides, opposite angles are equal and diagonals bisect each other but are not congruent. A rhombus has all of these properties with the additional properties that all sides are congruent and the diagonals bisect each other at right angles.
- 1c. **SOME** trapezoids are rectangles. All rectangles are trapezoids, but not all trapezoids are rectangles.
- 1d. **SOME** kites are rhombuses. A kite has two pairs of adjacent congruent sides and if all four sides are congruent then the kite is a rhombus.
2. A **kite** is the only quadrilateral in the list that does not have to have at least one pair of parallel sides.
3. The diagonals in a **rectangle, square, parallelogram** and **rhombus** must bisect each other. The diagonals in **trapezoids** and **kites** do not necessarily bisect each other.

### Collaborative task:

Shape A is a square:

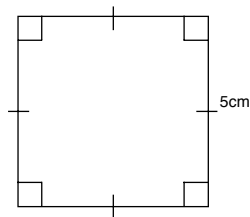

The minimal set of properties contains three cards, for example A2, A3, & A4 define the square.

**Shape B** is a rectangle:

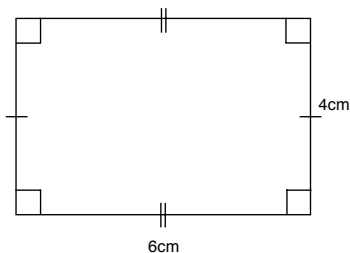

The minimal set of properties contains three cards, for example B1, B3, & B5 define the rectangle.

**Shape C** is a parallelogram:

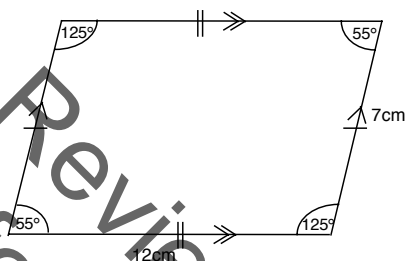

The minimal set of properties contains four cards, for example C2, C3, C4, & C5 define the parallelogram.

**Shape D** is a rhombus:

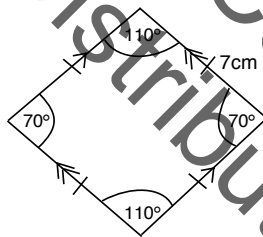

The minimal set of properties contains three cards, for example D2, D3, & D5 define the rhombus.

**Shape E** is a kite:

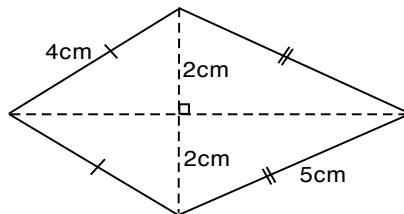

The minimal set of properties contains four cards, for example E1, E2, E4, & E5 define the kite.

No angles are given for **Shape E** so when students are sketching the kite they will not be able to label any angles on their sketch. However, it is possible to construct the kite from the information given.

Shape F is an isosceles trapezoid:

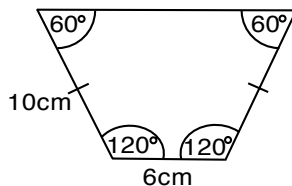

The length of the longest side of the trapezoid is not given in the properties of **Shape F** so students will not be able to label the length of this side on their sketch. However, it is possible to construct the trapezoid from the information given.

All five cards are needed to define the trapezoid.

**Note:** Some students may sketch Shape F as shown below:

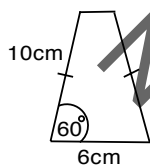

This is not possible to draw

**Assessment task: Classifying Quadrilaterals (revisited)**

- 1a. **ALL** rectangles are parallelograms. A rectangle has all of the properties of a parallelogram with the additional properties of four congruent angles and congruent diagonals.
- 1b. **SOME** parallelograms are squares. Parallelograms have congruent and parallel opposite sides, opposite angles are equal and diagonals bisect each other. Squares have four congruent sides and four congruent angles and diagonals that bisect each other.
- 1c. **ALL** squares are rhombuses. A square is a rhombus with four congruent angles so all squares are rhombuses.
- 1d. **SOME** trapezoids are kites. A trapezoid with two pairs of adjacent sides equal (i.e. it is a rhombus) is also a kite.
2. A **rectangle**, a **square**, a **parallelogram**, a **kite**, and a **rhombus** all have at least one pair of congruent sides. A **trapezoid** is the only quadrilateral in the list that does not necessarily have at least one pair of congruent sides.
3. **Squares** and **rhombuses** are the only quadrilaterals in the list with diagonals that bisect each other at right angles.

## Classifying Quadrilaterals

1. Complete the boxes below with the word **'All'**, **'Some'** or **'No'** to make the statements about quadrilaterals correct, giving reasons for your word choice. Your reasons can include diagrams.

a.  rectangles are squares.

Reason for your choice of word:

.....  
.....  
.....

b.  rhombuses are parallelograms.

Reason for your choice of word:

.....  
.....  
.....

c.  trapezoids are rectangles.

Reason for your choice of word:

.....  
.....  
.....

d.  kites are rhombuses.

Reason for your choice of word:

.....  
.....  
.....

2. Which of the following quadrilaterals must have at least one pair of parallel sides?  
Circle all that apply.

Rectangle	Square	Trapezoid	Parallelogram	Kite	Rhombus
-----------	--------	-----------	---------------	------	---------

Explain your answer:

.....

.....

.....

3. In which of the following quadrilaterals do the diagonals bisect each other?  
Circle all that apply.

Rectangle	Square	Trapezoid	Parallelogram	Kite	Rhombus
-----------	--------	-----------	---------------	------	---------

Explain your answer:

.....

.....

.....

Not for Review Copy  
Distribution



## Card Set: Properties

A1 The diagonals of the shape are congruent	A2 The shape has at least one side that is 5cm long	A3 The diagonals of the shape bisect each other at right angles	A4 The shape has 4 equal angles	A5 The shape has two pairs of parallel sides
--	--	--	------------------------------------	---

B1 The shape has at least one side that is 4cm long	B2 The diagonals of the shape bisect each other	B3 The shape has 4 equal angles	B4 Opposite sides of the shape are congruent	B5 The shape has at least one side that is 6cm long
--	--	------------------------------------	---	--

C1 The diagonals of the shape are not congruent	C2 The shape has at least one side that is 12cm long	C3 The shape has at least one side that is 7cm long	C4 The shape contains at least one $55^\circ$ angle	C5 Opposite sides of the shape are parallel
--	---	--	--	--

D1 The diagonals of the shape bisect each other at right angles	D2 All four sides are congruent	D3 The shape contains at least one $70^\circ$ angle	D4 Opposite sides of the shape are parallel	D5 The shape has at least one side that is 7cm long
--	------------------------------------	--	--	--

E1 The shape has at least one side that is 5cm long	E2 One diagonal bisects the other diagonal into two 2cm segments	E3 The shape has two pairs of congruent sides	E4 The diagonals of the shape intersect each other at right angles	E5 The shape has at least one side that is 4cm long
--	---	--	---	--

F1 The shape contains exactly one pair of parallel sides	F2 The shape has more than one side that is 10cm long	F3 The shape contains at least one $60^\circ$ angle	F4 The shape has a side that is 6cm long	F5 The shape contains a pair of opposite sides that are congruent
---	--	--	---	--

## Sketching Quadrilaterals

Sketch the quadrilateral and label it appropriately:



What is the mathematical name of the quadrilateral? .....

Find the **smallest** number of property cards that you need to *define* the quadrilateral.

Cut out and stick them below:



Explain how you know that you need **all** of these cards to define the quadrilateral:

.....

.....

.....

.....

.....

.....

.....

## Classifying Quadrilaterals (revisited)

1. Complete the boxes below with the word **'All'**, **'Some'** or **'No'** to make the statements about quadrilaterals correct, giving reasons for your word choice. Your reasons can include diagrams.

a.  rectangles are parallelograms.

Reason for your choice of word:

.....  
.....  
.....

b.  parallelograms are squares.

Reason for your choice of word:

.....  
.....  
.....

c.  squares are rhombuses.

Reason for your choice of word:

.....  
.....  
.....

d.  trapezoids are kites.

Reason for your choice of word:

.....  
.....  
.....

2. Which of the following quadrilaterals must have at least one pair of congruent sides?  
Circle all that apply.

Rectangle	Square	Trapezoid	Parallelogram	Kite	Rhombus
-----------	--------	-----------	---------------	------	---------

Explain your answer:

.....

.....

.....

3. Which of the following quadrilaterals' diagonals must bisect each other at right angles?  
Circle all that apply.

Rectangle	Square	Trapezoid	Parallelogram	Kite	Rhombus
-----------	--------	-----------	---------------	------	---------

Explain your answer:

.....

.....

.....

Not for Review Copy  
Distribution

## Shape Definitions

- Parallelogram:** Quadrilateral with two pairs of parallel sides.
- Rectangle:** Quadrilateral where all four angles are right angles.
- Square:** Quadrilateral where all four sides are of equal length and all four angles are right angles.
- Rhombus:** Quadrilateral where all four sides are of equal length.
- Kite:** Quadrilateral where two pairs of adjacent sides are of equal length.
- Trapezoid:** Quadrilateral where at least one pair of opposite sides are parallel.

# A Square

Review Copy  
Not for Distribution

P-2

Describing and Defining Quadrilaterals

Projector Resources

## Working Individually

1. Each strip of 5 properties describes a quadrilateral. Each person should select just one set.
2. For this set, draw the quadrilateral described by the 5 properties on your mini-whiteboard. Name the quadrilateral you have drawn. Label the sides and angles.
3. Now select the **smallest** number of cards you need in order to define the shape and size of the quadrilateral.
4. Be prepared to explain to your partner how you know that the shape you have sketched is correct and why you only need these cards to define it.

## Sharing Work

1. Take turns to share your drawing and explanation with your partner. Ask questions if you do not understand an explanation.
2. Make sure you both agree and can explain:
  - why your chosen cards define the shape and size of your quadrilateral,
  - why this is the smallest number of cards needed.
3. Complete the *Sketching Quadrilaterals* sheet, gluing down the cards in the agreed order.



## Working Collaboratively

1. Work together to complete the remaining property sets.
2. Take turns to select cards, justifying your choice.
3. If there is disagreement, explain your reasoning.
4. When you both agree, complete the *Sketching Quadrilaterals* sheet before moving on to the next set of properties.

# Property Card Set A

A1	The diagonals of the shape are congruent	A2	The shape has at least one side that is 5cm long	A3	The diagonals of the shape bisect each other at right angles	A4	The shape has 4 equal angles	A5	The shape has two pairs of parallel sides
----	--	----	--	----	--	----	------------------------------	----	---

# Property Card Set B

B1	The shape has at least one side that is 4cm long
B2	The diagonals of the shape bisect each other
B3	The shape has 4 equal angles
B4	Opposite sides of the shape are congruent
B5	The shape has at least one side that is 6cm long

Not for Review Copy Distribution

# Property Card Set C

C1	The diagonals of the shape are not congruent	C2	The shape has at least one side that is 12cm long	C3	The shape has at least one side that is 7cm long	C4	The shape contains at least one 55° angle	C5	Opposite sides of the shape are parallel
----	--	----	---	----	--	----	---	----	--

Not for Redistribution  
Copyright

# Property Card Set D

D1	The diagonals of the shape bisect each other at right angles	D2	All four sides are congruent	D3	The shape contains at least one $70^\circ$ angle	D4	Opposite sides of the shape are parallel	D5	The shape has at least one side that is 7cm long
----	--	----	------------------------------	----	--	----	--	----	--

# Property Card Set E

E1 The shape has at least one side that is 5cm long	E2 One diagonal bisects the other diagonal into two 2cm segments	E3 The shape has two pairs of congruent sides	E4 The diagonals of the shape intersect each other at right angles	E5 The shape has at least one side that is 4cm long
--	---	--	---	--

# Property Card Set F

F1	The shape contains exactly one pair of parallel sides
F2	The shape has more than one side that is 10cm long
F3	The shape contains at least one $60^\circ$ angle
F4	The shape has a side that is 6cm long
F5	The shape contains a pair of opposite sides that are congruent

## Mathematics Assessment Project **Classroom Challenges**

These materials were designed and developed by the  
Shell Center Team at the Center for Research in Mathematical Education  
University of Nottingham, England:

**Malcolm Swan,**  
**Nichola Clarke, Clare Dawson, Sheila Evans, Colin Foster, and Marie Joubert**  
with  
**Hugh Burkhardt, Rita Crust, Andy Noyes, and Daniel Pead**

We are grateful to the many teachers and students, in the UK and the US,  
who took part in the classroom trials that played a critical role in developing these materials

The classroom observation teams in the US were led by  
**David Foster, Mary Bouck, and Diane Schaefer**

This project was conceived and directed for  
The Mathematics Assessment Resource Service (MARS) by  
**Alan Schoenfeld** at the University of California, Berkeley, and  
**Hugh Burkhardt, Daniel Pead, and Malcolm Swan** at the University of Nottingham

Thanks also to Mat Crosier, Anne Floyde, Michael Galan, Judith Mills, Nick Orchard, and Alvaro Villanueva who contributed to the design and production of these materials

This development would not have been possible without the support of  
**Bill & Melinda Gates Foundation**

We are particularly grateful to  
**Carina Wong, Melissa Chabran, and Jamie McKee**

The full collection of Mathematics Assessment Project materials is available from

<http://map.mathshell.org>

© 2015 MARS, Shell Center, University of Nottingham  
This material may be reproduced and distributed, without modification, for non-commercial purposes,  
under the Creative Commons License detailed at <http://creativecommons.org/licenses/by-nc-nd/3.0/>  
All other rights reserved.

Please contact [map.info@mathshell.org](mailto:map.info@mathshell.org) if this license does not meet your needs.



## Geometry

# Lesson 6 of 9

## Slicing 3-D Figures

### Description:

Up to this point, students have only been concerned with two-dimensional figures. In this lesson, students will study the two-dimensional figures that result from slicing solid three-dimensional figures. They will be given the opportunity to sketch, model, and describe cross-sections formed by a plane passing through a three-dimensional figures.

### College- and Career-Readiness Standards Addressed:

- G.3 Describe the two-dimensional figures that result from slicing three dimensional figures, as in plane sections of right rectangular prisms and right rectangular pyramids.

### Process Readiness Indicators Emphasized:

- PRI 1: Make sense of problems and persevere in solving through reasoning and exploration.
- PRI 2: Reason abstractly and quantitatively by using multiple forms of representations to make sense of and understand mathematics.
- PRI 4: Contextualize mathematical ideas by connecting them to real world situations. Model with mathematics.
- PRI 8: Look for and express regularity in repeated reasoning.
- PRI 10: Reflect on mistakes and misconceptions to improve mathematical understanding.

### PRI 10

Sequence of  
Instruction

Activities Checklist

### Engage

Show the three and a half minute Cyberchase video “Bianco Gets Crystal Clear” found at <http://pbskids.org/cyberchase/videos/cyberchase-bianca-gets-crystal-clear/>. Bianco’s little cousin Antonio asks her to help him make rock candy and, while waiting for the sugar crystals to form, teaches her about the geometry of crystals.

▶ **Commentary for the Teacher:** (If you would like for the students to make Rock Candy, here are two YouTube videos with recipe and steps <https://www.youtube.com/watch?v=VT4RI7soco0> or <https://www.youtube.com/watch?v=GdH577EJdte>)

Depending on the level of your students, choose one of the two following activities where they will use geometry to make flat shapes “rise up” into 3D objects.

1. <http://pbskids.org/cyberchase/activities/2d-to-3d-morphing/>  
Click on “Print” button to print instructions and needed cutouts.
2. No cutting:  
<http://www.mathworksheets4kids.com/solid-shapes/net-shape2.pdf>

Answer sheet included.

## Explore

PRI 1  
PRI 4  
PRI 8

**Hook:** Ask “Can you make a hexagon from a cube with just one slice?” \*\* Yes

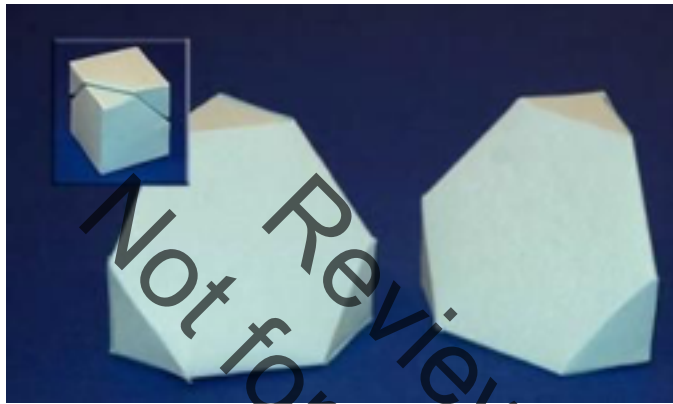

In this lesson, students will sketch, model, and describe cross-sections formed by a plane passing through three-dimensional figures. Students will create a cube, right rectangular prism, and right rectangular pyramid using modeling clay or Play-doh, slice the model using parallel, perpendicular, and intersecting lines and describe the two-dimensional figure resulting from slicing the three-dimensional models with dental floss. The accompanying worksheet will aid them in making sense of the problems and persevering in solving through reasoning and exploration. If you would like to start with a visual, [http://www.pbslearningmedia.org/asset/mgbh\\_int\\_xsection/](http://www.pbslearningmedia.org/asset/mgbh_int_xsection/) allows you to project cutting through a cube with a virtual sword and observe the resulting cross sections. This interactive exercise focuses on discovering the relationships between two and three-dimensional shapes. This resource is part of the *Math at the Core: Middle School* collection.

Materials needed:

- Modeling clay or Play-doh for each student. The small “party favor” Play-doh containers work very well for this lesson and gives each student adequate material to create their three-dimensional models.
- Plastic knives, dental floss, jewelry filament or fishing line to cut the cross-sections.
- Pencils
- Work mats or some other covering for desks.
- Task #18: Can You Cut It? Slicing Three-Dimensional Figures

A cross section is the face you get when you make one slice through an object. Below is a sample slice through a cube, showing one of the cross sections you can get.

The polygon formed by the slice is the cross-section. The cross-section cannot contain any piece of the original face; it all comes from “inside” the solid. In this picture, only the gray piece is a cross section.

Introduce the concept of cross-sections and ask students to discuss real-life examples such as doll houses, models, tree trunk cutting. Ask students if they can find examples from their textbooks in other classes.

Distribute the modeling clay or Play-doh as well as the Activity Sheet Task #18: Can you Cut it? Slicing Three-Dimensional Figures (included in Student Manual). Students may be paired or work in small groups as they make discoveries through repeated reasoning.

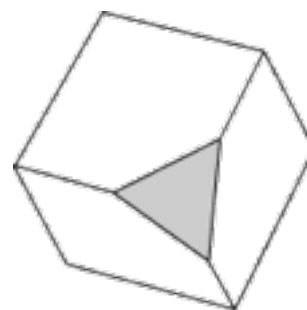

## Explanation

INCLUDED IN THE STUDENT MANUAL

### Task #18: Can You Cut It? Slicing Three-Dimensional Figures

#### 1. The Cube

- Using modeling clay or play-doh, each student creates a model of a cube.
- With your group, predict the type of shapes you could see by cutting the cube at different places and different angles. Do not actually make any cuts, but envision what they would look like and write your predictions below:

Description of “slice” made:	Prediction of shape formed (cross-section):

- Using a plastic knife or dental floss, slice through the middle of the model cube in a direction perpendicular to the base.

To the right, sketch, describe, and name the figure formed by the cross-section.	
--	--

<p>If the slice was made in a different area (but still perpendicular to the base), would the shape of the cross-section be the same or different? Explain your thinking in the box to the right.</p>	<hr/> <hr/> <hr/> <hr/> <hr/> <hr/> <hr/> <hr/>
---	---

- Put your model back together again before continuing.
- Slice through the middle of the model cube in a direction parallel to the base.

<p>To the right, sketch, describe, and name the figure formed by the cross-section.</p>	<hr/> <hr/> <hr/> <hr/> <hr/> <hr/> <hr/> <hr/>
---	---

<p>If the slice was made in a different area (but still perpendicular to the base), would the shape of the cross-section be the same or different? Explain your thinking in the box to the right.</p>	<hr/> <hr/> <hr/> <hr/> <hr/> <hr/> <hr/> <hr/>
---	---

- What do you notice about all the cross-sections formed by the intersection of a plane that is either parallel or perpendicular to the base of a cube?

---

---

- Put the cube back together and create a cross-section that would make a triangle shape. Describe what you did and how you did it.

---

---

---

---

- Compare and contrast your group's triangles to other group's triangles. Are the cross-sections the same? Explain.

---

---

---

---

- Create other cross-sections with as many two-dimensional shapes as you can. List and explain your steps.

---

---

---

---

- Are there any two-dimensional shapes that you cannot create from the model? Explain why.

---

---

---

---

- Can you make a hexagon from a cube with just one slice? Explain.

---

---

---

---

Not for Review Copy  
Distribution

## 2. Rectangular Prisms

- Using modeling clay or play-doh, create a right rectangular prism that is not a cube.
- With your group, predict the type of shapes you could see by cutting the prism at different places and different angles. Do not actually make any cuts, but envision what they would look like and write your predictions below:

Description of "slice" made:	Prediction of shape formed (cross-section):

- Using a plastic knife or dental floss, slice through the middle of the model prism in a direction that is perpendicular to the base (and parallel to the faces).

<p>To the right, sketch, describe, and name the figure formed by the cross-section.</p>	<p> </p>
---	----------

<p>If the slice was made in a different area (but still perpendicular to the base), would the shape of the cross-section be the same or different? Explain your thinking in the box to the right.</p>	<p> </p> <hr/> <hr/> <hr/> <hr/> <hr/> <hr/> <hr/>
---	--

- Put your model back together again before continuing.
- Slice through the middle of the model prism in a direction parallel to the base.

<p>To the right, sketch, describe, and name the figure formed by the cross-section.</p>	
---	--

<p>If the slice was made in a different area (but still perpendicular to the base), would the shape of the cross-section be the same or different? Explain your thinking in the box to the right.</p>	<hr/> <hr/> <hr/> <hr/> <hr/> <hr/> <hr/> <hr/> <hr/> <hr/>
---	---

- What do you notice about all the cross-sections formed by the intersection of a plane that is either parallel or perpendicular to the base of a prism?  

---

---
- Put the cube back together and create a cross-section that would make a triangle shape. Describe what you did and how you did it.  

---

---

---

---
- Compare and contrast your group's triangles to other group's triangles. Are the cross-sections the same? Are different types of triangles created? Would you classify these triangles by their angles or sides?  

---

---

---

---

- Create other cross-sections in the shapes of pentagons, hexagons, and parallelograms. List and explain your steps.

---



---



---



---

- Can you create more or less shapes with a rectangular prism than a cube? Explain your answer.

---



---



---



---

### 3. Right Rectangular Pyramids

- Using modeling clay or play-doh, create a right rectangular pyramid.
- With your group, predict the type of shapes you could see by cutting the pyramid at different places and different angles. Do not actually make any cuts, but envision what they would look like and write your predictions below:

Description of "slice" made:	Prediction of shape formed (cross-section):

- Using a plastic knife or dental floss, slice through the middle of the model pyramid in a direction that is perpendicular to the base (and slices through the vertex).



<p>To the right, sketch, describe, and name the figure formed by the cross-section.</p>	
---	--

<p>If the slice was made in a different area (but still perpendicular to the base), would the shape of the cross-section be the same or different? Explain your thinking in the box to the right.</p>	<hr/> <hr/> <hr/> <hr/> <hr/> <hr/> <hr/> <hr/>
---	---

- Put your model pyramid back together again before continuing.
- Slice through the middle of the model pyramid in a direction parallel to the base.

<p>To the right, sketch, describe, and name the figure formed by the cross-section.</p>	
---	--

<p>If the slice was made in a different area (but still perpendicular to the base), would the shape of the cross-section be the same or different? Explain your thinking in the box to the right.</p>	<hr/> <hr/> <hr/> <hr/> <hr/> <hr/> <hr/> <hr/>
---	---

- Put your pyramid back together and slice through the pyramid in a direction that is neither parallel nor perpendicular to the base. Sketch and describe the figure(s) formed.

Who doesn't love taking things apart to see how they work? Students may have dissected a frog in science class.

Three-dimensional solids are the same way. We're used to seeing a cube as a cube, but all kinds of interesting things happen when we start cutting it up to look at its insides, and thankfully, geometry smells a lot nicer than the biology lab.

Students should know that slicing and dicing a 3D solid will give us a 2D cross section, like a slice of bread or a chopped up carrot. Really emphasize the fact that the same 3D shape can have a lot of different 2D cross sections, depending on how we slice it. Cutting off the corner of a rectangular prism will give us a triangle, but cutting it parallel to one of its faces gives us a rectangle. We can even come up with all kinds of unexpected polygons if we slice it at odd angles.

### Practice Together / in Small Groups / Individually

#### PRI 2

#### Task #19: Cross Sections Practice

INCLUDED IN THE STUDENT MANUAL

#### Task #19: Cross Sections Practice

For problem 1, choose all of the possible shapes that can be made by intersecting a rectangular prism.

For problems 2-8, draw the cross section formed when the plane indicated intersects the shape.

1.
  - a. a square
  - b. an equilateral triangle
  - c. a rectangle (not a square)
  - d. a triangle (not equilateral)
  - e. a pentagon
  - f. a hexagon
  - g. an octagon
  - h. a parallelogram (not a rectangle)
  - i. a circle

1.	2.
3.	4.
5.	6.
7.	8.

Not for Review Copy  
Distribution

Anticipated Responses for Practice Phase:

1. a, b, c, d, e, f, h

Solutions for problems 2-8 can be found at [http://www.learner.org/courses/learningmath/geometry/session9/solutions\\_c.html#c1](http://www.learner.org/courses/learningmath/geometry/session9/solutions_c.html#c1).

Provide the opportunity for students to reflect on their mistakes and misconceptions to improve their understanding.

### Evaluate Understanding





Direct students to Task #20: “Can You Cut It? Slicing Three Dimensional Figures Assessment” in their Student Manual.

(From <http://www.cpalms.org/Public/PreviewResourceLesson/Preview/47309>)

INCLUDED IN THE STUDENT MANUAL

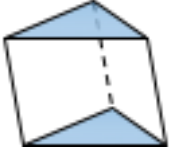



**Task #20: Can You Cut It? Slicing Three Dimensional Figures**

Select four (4) of the figures below and describe the two dimensional figure(s) created from cross section after cuts made that are parallel to the base and perpendicular to the base.

Figure	Parallel Cut	Perpendicular Cut
		
		
		
		
		

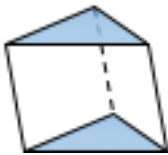
Not for Review Copy  
Distribution

Answer Key

Figure	Parallel Cut	Perpendicular Cut	Comments
	Two-dimensional slice would be a triangle.	Two-dimensional slice would be a rectangle	
	Two-dimensional slice would be a pentagon.	Two-dimensional slice would be a rectangle	Some students may draw a picture which represents a trapezoid or a figure that shows exactly where they sliced.
	Two-dimensional slice would be a hexagon.	Two-dimensional slice would be a rectangle	Some students may draw a picture which represents a trapezoid or a figure that shows exactly where they sliced.
	Two-dimensional slice would be a triangle.	Two-dimensional slice would be a triangle.	
	Two-dimensional slice would be a hexagon.	Two-dimensional slice would be a triangle.	Some students will show the parallel cut as a cone looking at the vertex.  Some students may represent the perpendicular slice differently.

Closing Activity

PRI 10

Ask students to work in pairs to reason abstractly and quantitatively to predict what two-dimensional figures the cross-sections of a cube will be if the cut can move in **any** direction, but it must move in a straight line from one face or side of the solid to another face or side. The following can be made from sections of a cube: triangle, square, rectangle, trapezoid, pentagon, and hexagon.

Suggestions:

1. Have students show the class their cross-sections, and create a list on the board. This is an excellent opportunity for reviewing polygons. You may wish to discuss with the class how moving, tilting and/or turning the slice changes the polygonal cross section.
2. Possible questions for a class discussion:
  - Could you have a cross-section with more than six sides?
  - How could you get an equilateral triangle as a cross-section?
  - Could you have a regular hexagon as a cross-section?
  - Could you have a regular pentagon as a cross-section?

INCLUDED IN THE STUDENT MANUAL

**Task #21: Lesson 6 Reflection**

1. Summarize what you learned in this lesson.

Not for Review Copy  
Distribution

---

---

---

---

---

---

---

---

---

---

2. How is this skill helpful in the real-world? Explain.

---

---

---

---

---

---

---

---

---

---

## Independent Practice

Task #22: Independent Practice for Lesson 6.

INCLUDED IN THE STUDENT MANUAL

### Task #22: Independent Practice for Lesson 6

1. The figure below shows a prism whose base is an equilateral triangle.

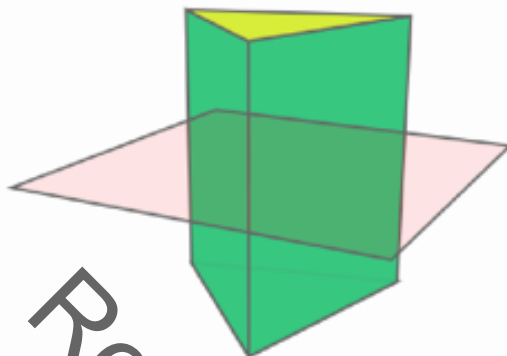

Which shape does the pink slice of the green prism look like?

Please choose from one of the following options.

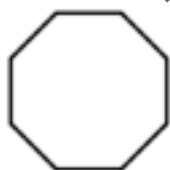

2. A vertical slice through a three-dimensional solid produces a two-dimensional shape.

Which one of the following solids can produce this two dimensional shape when sliced vertically?



Please choose from one of the following options.



KEY Task #22: "Independent Practice for Lesson 6"

1. The figure below shows a prism whose base is an equilateral triangle.

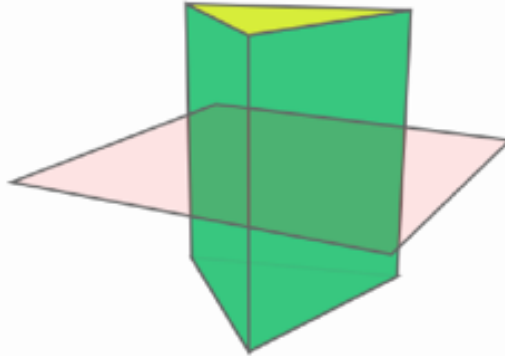

Which shape does the pink slice of the green prism look like?

Please choose from one of the following options. **triangle**



2. A vertical slice through a three-dimensional solid produces a two-dimensional shape.

Which one of the following solids can produce this two-dimensional shape when sliced vertically?



Please choose from one of the following options.

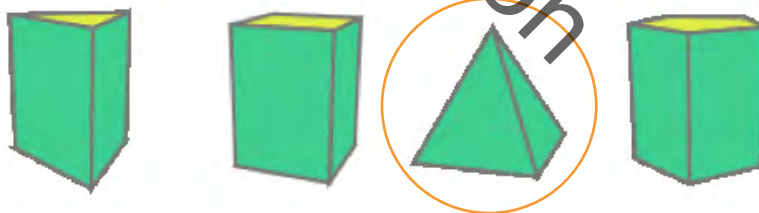



### Resources/Instructional Materials Needed:

---

Modeling clay or Play-doh for each student. The small “party favor” Play-doh containers work very well for this lesson and gives each student adequate material to create their three-dimensional models.

Plastic knives, dental floss, or fishing line to cut the cross sections.

Work mats or some other covering for desks.

If rock candy is made, sugar, pipe cleaners or sucker sticks, jars, pencils or clothes clips, and heat.

Task #18: Can You Cut It? Slicing Three-Dimensional Figures

Task #19: Cross Sections Practice

Task #20: Can You Cut It? Slicing Three Dimensional Figures Assessment

Task #21: Lesson 6 ReflectionTask

Task #22: Independent Practice for Lesson 6

Review Copy  
Not for Distribution

## Geometry

# Lesson 7 of 9

## Transformations

### Description:

---

Students are introduced to geometric transformations, specifically translations, rotations, reflections. They learn how, using physical models and geometry software, to perform the transformations, and how to map one figure into another using these transformations. This lesson will provide opportunities for students to understand congruence. Similar figures were introduced in unit two. By definition, congruent figures are also similar. It is incorrect to say that similar figures are the same shape, just a different size. This thinking leads students to misconceptions such as that all triangles are similar. It is important to add to that definition, the property of proportionality among similar figures.

### College- and Career-Readiness Standards Addressed:

---

- G.6 Verify experimentally the properties of rotations, reflections, and translations:
- G.7 Understand that a two-dimensional figure is congruent to another if the second can be obtained from the first by a sequence of rotations, reflections, and translations; given two congruent figures, describe a sequence that exhibits the congruence between them.
- G.8 Describe the effect of translations, rotations, and reflections on two-dimensional figures using coordinates.

### Process Readiness Indicators Emphasized:

---

- PR1: Make sense of problems and persevere in solving through reasoning and explanation
- PR2: Reason abstractly and quantitatively by using multiple forms of representation to make sense of and understand mathematics
- PRI 6: Attend to precision
- PRI 10: Reflect on mistakes and misconceptions to improve mathematical understanding
- PRI 6: Attend to precision

Sequence of Instruction

Activities Checklist

Engage

**Commentary for the Teacher:** We recommend grouping students by like abilities and with a group of two to four students each. This will allow the students to work at their own level and to be an active participant in the learning process.

**Hook:** In partners, provide students with a laptop, iPad, etc. If students do not have access to 1-to-1 or 2 digital devices, the teacher’s projector may be used. Have students go to the official Escher website at <http://www.mcescher.com/Shopmain/ShopEU/facsprints-uk/prints.html> and select a piece of artwork. Ask students to list characteristics in the artwork through the lens of a mathematician.

After about 5-10 minutes, allow groups to share the characteristics they found and list these on the board as they share. Ask students if they see any commonalities. Remind students that today we will be looking at properties of different transformations.

**Commentary for the Teacher:** If you have time, and wish to do so, students may create their own tessellation. Directions for creating a tessellation based on a parallelogram. (You may want to use dynamic geometry software such as Geometer’s Sketchpad or GeoGebra for the construction.)

- (1) Construct a parallelogram.
- (2) Construct a figure along one edge of the parallelogram.
- (3) Translate the figure to the opposite side of the parallelogram.
- (4) Construct a shape along one of the other sides of the parallelogram.
- (5) Translate the shape to the opposite side of the parallelogram.
- (6) Hide the original parallelogram.
- (7) Create the tessellation by translating the figure.
- (8) Color the interiors as desired.

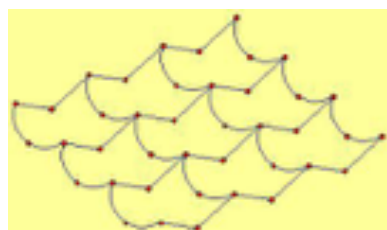
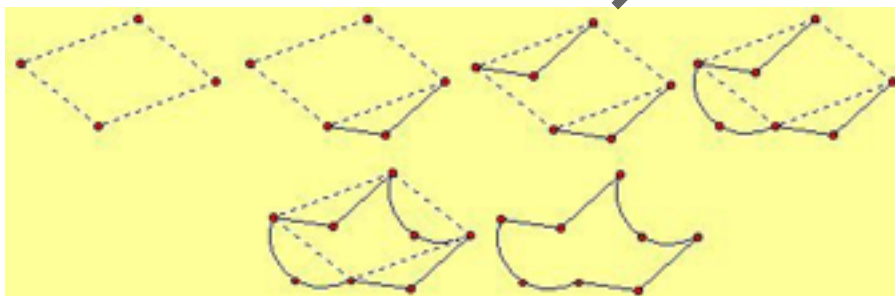

## Explore

### PRI 6

Students will explore transformations using Geoboards. Students will need Geoboard, bands, and a Data Chart. If you do not have Geoboards available, the following site is an excellent alternative:

<http://www.mathlearningcenter.org/web-apps/geoboard/>

(adapted from <http://wveis.k12.wv.us/teach21/cso/upload/UP74WS8.pdf>)

**Commentary for the Teacher:** *Students confuse the rules for transforming two-dimensional figures because they rely too heavily on rules as opposed to understanding what happens to figures as they translate, rotate, reflect, and dilate. It is important to have students describe the effects of each of the transformations on two-dimensional figures through the coordinates but also the visual transformations that result.*

#### Procedure:

1. Use two bands to mark the x and y axes with the origin being in the center of the Geoboard.
2. Place three different bands on the geoboard so that the vertices of a triangle are at  $A(-1, 1)$ ,  $B(-2, 1)$ ,  $C(0, 2)$
3. These three points represent the vertices of the original triangle.
4. Locate three new points  $A_1$ ,  $B_1$ , and  $C_1$  by moving 1 unit down and 1 unit to the right of each of the given points. Place bands to show the vertices of the image triangle  $A_1$ ,  $B_1$ , and  $C_1$  on the Geoboard. Record the required data in the first row of the chart.
5. Reflect  $\triangle ABC$  about the y-axis. Place bands to show the vertices of the image triangle  $A_2B_2C_2$  on the Geoboard. Record the required data in the second row of the chart.
6. Reflect  $\triangle ABC$  about the x-axis. Place bands to show the image triangle  $A_3B_3C_3$  on the Geoboard. Record the required data in the third row of the chart.
7. Rotate  $\triangle ABC$  as a whole,  $90^\circ$  clockwise, with the origin as the center of rotation. Place bands to show the image triangle  $A_4B_4C_4$  on the Geoboard. Record the required data in the fourth row of the chart.
8. Rotate  $\triangle ABC$  as a whole, counterclockwise  $90^\circ$ , with the origin as the center of rotation. Place bands to show the image triangle  $A_5B_5C_5$  on the Geoboard. Record the required data in the fifth row of the chart.
9. Use the information from the table to determine if each transformation is an isometry? (mappings from preimages to images that do not change the size or shape of the geometric figure)

Reiterate that a two dimensional figure is congruent to another if the second can be obtained from the first by a sequence of rotations, reflections, and translations; given two congruent figures, describe a sequence that exhibits the congruence between them.

INCLUDED IN THE STUDENT MANUAL

**Task #23: Transformations on a Geoboard**

Original Triangle Coordinates	Image Triangle Coordinates	Are lengths the same?	Are angle measures the same?	If points are collinear, are their images collinear?	If a point is a midpoint of a segment, is its image a midpoint (of the image segment)?	Is the orientation the same if read clockwise?
A(-1, 1) B(-2, 1) C(0,2)						
A(-1, 1) B(-2, 1) C(0,2)						
A(-1, 1) B(-2, 1) C(0,2)						
A(-1, 1) B(-2, 1) C(0,2)						
A(-1, 1) B(-2, 1) C(0,2)						

Not for Review Copy  
Distribution

**Key Task #23: Transformations on a Geoboard**

Original Triangle Coordinates	Image Triangle Coordinates	Are lengths the same?	Are angle measures the same?	If points are collinear, are their images collinear?	If a point is a midpoint of a segment, is its image a midpoint (of the image segment)?	Is the orientation the same if read clockwise?
A(-1, 1) B(-2, 1) C(0,2)	A <sub>1</sub> (0,0) B <sub>1</sub> (-1,0) C <sub>1</sub> (1,1)	Yes	Yes	Yes	Yes	Yes
A(-1, 1) B(-2, 1) C(0,2)	A <sub>2</sub> (1,1) B <sub>2</sub> (2,1) C <sub>2</sub> (0,2)	Yes	Yes	Yes	Yes	No
A(-1, 1) B(-2, 1) C(0,2)	A <sub>3</sub> (-1,1) B <sub>3</sub> (-2,1) C <sub>3</sub> (0,-2)	Yes	Yes	Yes	Yes	No
A(-1, 1) B(-2, 1) C(0,2)	A <sub>4</sub> (1,1) B <sub>4</sub> (1,2) C <sub>4</sub> (2,0)	Yes	Yes	Yes	Yes	Yes
A(-1, 1) B(-2, 1) C(0,2)	A <sub>5</sub> (-1,-1) B <sub>5</sub> (-1,-2) C <sub>5</sub> (-2,0)	Yes	Yes	Yes	Yes	Yes

Not for Review Copy Distribution

## Explanation

---

### PRI 2

The following activity comes from [Shodor.org](http://www.shodor.org). It will allow the students to reason abstractly by using multiple forms of representation to make sense of and understand mathematics.

- Open your browser to The TransmoGrapher <http://www.shodor.org/interactivate/activities/TransmograpHer/> in order to demonstrate this activity to the students.
- Show the class how to choose the shape they wish to translate, rotate, or reflect using the buttons at the top of the applet.
- Explain that they must pay close attention to the color of each side of the shape in order to see that the shape has been rotated, translated, or reflected.
- Show the class how to enter a distance to translate, a degree by which to rotate, or a line of symmetry over which to reflect the object.

### Practice Together / in Small Groups / Individually

---

Direct students to the Task #24: Translations, Reflections, and Rotations Worksheet in their student manual.

- Walk the students through the first problem on the sheet. Help them by reminding them as you walk around the room what “rotate”, “fourth quadrant”, and “reflect” mean.
- If the students needed a lot of help with the first problem, walk them through the second problem on triangles as well.
- Instruct students to work independently on the remainder of this worksheet. Monitor the room for questions and be sure that the students are on the correct web site. Encourage students to persevere in their problem solving.
- Students should understand that a two-dimensional figure is congruent to another if the second can be obtained from the first by a sequence of rotations, reflections, and translations; given two congruent figures, students will describe a sequence that exhibits the congruence between them. After students have completed the worksheet, have each student choose a figure and apply 2 transformations to it (noting what he or she did). Then have students change places and try to determine how to undo each transformation.

INCLUDED IN THE STUDENT MANUAL

### Task #24: Translations, Reflections, and Rotations

What defines a right triangle?

---

---

What is the area of a square?

---

---

How are the angles and the sides opposite them related?

---

---

How are the blue squares related?

---

---

How are the two non-right angles related?

---

---

How are the sides related in a right triangle?

---

---

### Evaluate Understanding

#### PRI 6

Assess student understanding by having students play the online game Transformation Golf. This game will allow them to reflect on mistakes and misconceptions to improve their mathematical understanding.

Distribute Task #25: "Transformation Golf" worksheet. (Student Manual) Students will utilize translations, reflections, and rotations on a golf ball in the coordinate plane as they attempt to find the most efficient method (minimum number of transformations) to get the golf ball into the "hole." Observe the strategies that each student uses to minimize the number of moves needed. Remind students that only the golf ball is moved to its image point in the transformation that they select; the "hole" is not moved.

<http://www.hoodamath.com/mobile/games/transformationgolf.html>

**Directions:** Get the White Ball into the Black Hole. Pick a Transformation and then a factor choice of that transformation. Translation gives the option to move up, down, left, or right one unit. Rotation gives the option to rotate clockwise or counterclockwise, 90 or 180 degrees. Reflection gives the option to reflect over x-axis, y-axis,  $y=x$ , or  $y=-x$ . Dilation gives the scale factor option of multiplying the radius by 2 or 3, or by  $1/2$  or  $1/3$ . There are 9 holes. Try to get par on each hole. If you are in trouble press restart to redo a hole before you complete it.



An additional form of the game can be found at <http://www.hoodamath.com/mobile/games/transformationgolf.html>.

This is an excellent resource for being interactive with the class on the whiteboard. Also useful to provide some fun revision once the students have fully understood the transformation concepts.

**INCLUDED IN THE STUDENT MANUAL**

**Task #25: Transformation Golf**

1. Read the instructions of how to play the game.
2. Select to play all 9 holes.
3. Play each hole. Your goal is to make par or stay below par on each hole. You want to make as few moves as possible.
4. After you have completed 9 holes, click view your score card and have a teacher mark down your score and initial your menu.

<b>Points</b>	<b>10</b>	<b>9</b>	<b>8</b>	<b>7</b>	<b>6</b>
Game Score	Score at or below par	Score 14 over par.	Score 58 over par.	Score 912 over par.	Score
<b>Points</b>	<b>10</b>	<b>9</b>	<b>8</b>	<b>7</b>	<b>6</b>
Game Score	Score at or below par	Score 14 over par.	Score 58 over par.	Score 912 over par.	Score

**Closing Activity**

Students work together to complete Task #26 TransmoGrapher Exploration Questions included in the Student Manual.

**INCLUDED IN THE STUDENT MANUAL**

**Task #26: TransmoGrapher Exploration Questions**

1. Pick a partner and each of you translate, reflect, and rotate a triangle as much as you want making sure you keep track of the transformations you used. Now switch computers and see if you can get your partner's triangle back to its home position (also keeping track of the transformations you made). Now compare the translations you made to move the triangle with your partner's moves to get it back to its original position. Are they the same? Explain.  
  
\_\_\_\_\_  
  
\_\_\_\_\_
2. Pick a partner and each of you translate, reflect, and rotate a square as much as you want keeping track of the transformations you used. Now switch computers and see if you can get your partner's square back into its home position (also keeping track of the transformations you used). Now compare the moves you did to move the square with your partner's moves to get it back. Are they the same? Explain.

3. Pick a partner and each of you translate, reflect, and rotate a parallelogram as much as you want and keeping track of the transformations you used. Now switch computers and see if you can get your partners parallelogram back in to its home position also keeping track of the transformations you used). Now compare the moves you did to move the parallelogram with your partner's moves to get it back. Are they the same? Explain.

Optionally have students dynamically interact with various transformations using any of the following internet sites

<https://www.ixl.com/math/grade-8/identify-reflections-rotations-and-translations>

<https://www.khanacademy.org/math/geometry/congruence/transformations-congruence/e/exploring-rigid-transformations-and-congruence>

<https://www.mangahigh.com/en-us/games/transtar>

INCLUDED IN THE STUDENT MANUAL

### Task #27: Lesson 7 Reflection

1. Summarize what you learned in this lesson.

2. How is this skill helpful in the real-world? Explain.

### Independent Practice:

Assign Task #28: Let's Show What We Know Practice Worksheet found in Student Manual.

INCLUDED IN THE STUDENT MANUAL

**Task #28: Let's Show What We Know**

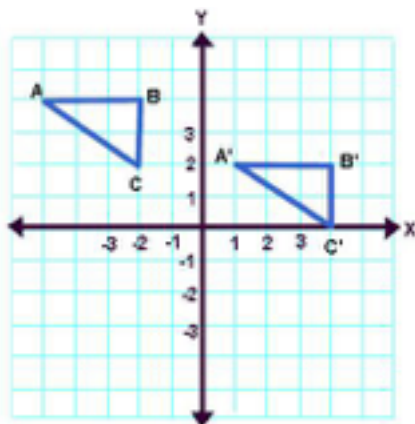

1. This graph illustrates a translation of  $(6, -2)$ . True or false?

2. Under a translation of 5 units up and 2 units to the left, the point  $(3, 4)$  will become  $(8, 6)$ . True or false?

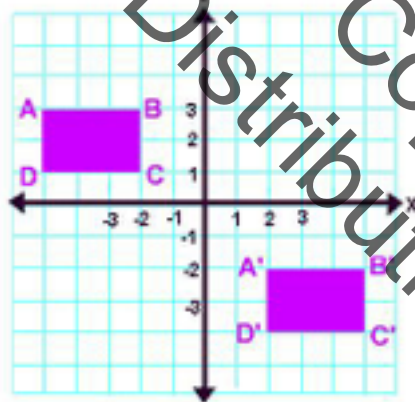

3. Describe the translation that will move rectangle  $ABCD$  onto Rectangle  $A'B'C'D'$ .

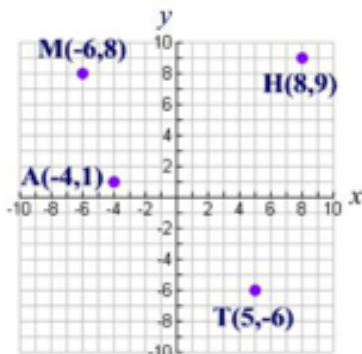

4. A translation maps the origin to the point  $(-3, 1)$ . Graph the images of the points  $M$ ,  $A$ ,  $T$  and  $H$  under this same translation.

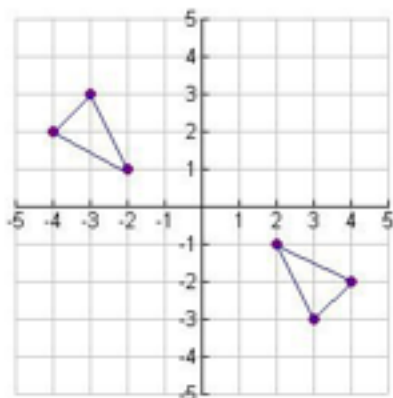

5. Which of the following transformations is illustrated by the graph at the above?
- a. dilation
- b. reflection in  $y = x$
- c. translation
- d. reflection in the origin
6. A positive angle of rotation turns a figure
1. clockwise       2. counterclockwise
7. What are the coordinates of point origin?  $T$ , the image of point  $T(-2,5)$  after a reflection in the origin?
1. (2,5)       2. (2,-5)       3. (-2,-5)       4. (5,-2)
8. The translation image of a segment is a segment \_\_\_\_\_ and \_\_\_\_\_ to the original segment.

Answers:

1. True
2. False
3. Move
- 4.
5. D
6. 2
7. 2
8. Congruent and parallel

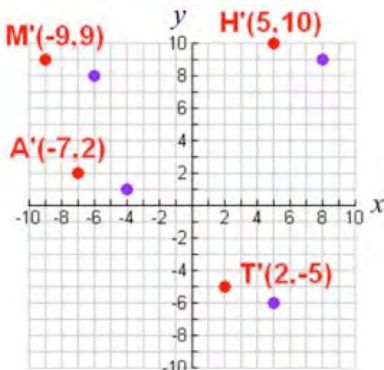

Internet sites referenced:

<http://www.hoodamath.com/mobile/games/transformationgolf.html>

<http://www.mcescher.com/Shopmain/ShopEU/facsprints-uk/prints.html>

<http://web.mnstate.edu/peil/geometry/c3transform/JavaSketch/0Intro.htm>

<https://www.khanacademy.org/math/geometry/congruence/transformations-congruence/e/exploring-rigid-transformations-and-congruence>

<http://www.shodor.org/interactivate/discussions/TranslationsReflecti/>

<http://www.shodor.org/interactivate/activities/TransmograpHer/>

<https://www.ixl.com/math/grade-8/identify-reflections-rotations-and-translations>

<http://www.mathlearningcenter.org/web-apps/geoboard/>

## Resources:

---

Task #23: Transformations on a Geoboard

Task #24: Translations, Reflections, and Rotations

Task #25: Transformation Golf

Task #26: TransmoGrapher Exploration Questions

Task #27: Reflections on Lesson 7

Task #28: Let's Show What We Know

Geoboards

Geobands

Not for Review Copy  
Distribution

## Geometry

# Lesson 8 of 9

## FAL Representing and Combining Transformations

### Description:

---

This lesson is intended to help you assess how well students are able to:

- Recognize and visualize transformations of 2D shapes.
- Translate, reflect and rotate shapes, and combine these transformations.

It also will aid in encouraging discussion on some common misconceptions about transformations.

<http://map.mathshell.org/lessons.php?unit=8310&collection=8>

### College- and Career-Readiness Standards Addressed:

---

- G.9 1. Verify experimentally the properties of rotations, reflections, and translations:
  - a. Lines are taken to lines, and line segments to line segments of the same length.
  - b. Angles are taken to angles of the same measure.
  - c. Parallel lines are taken to parallel lines.
- G.10 Describe the effect of dilations, translations, rotations, and reflections on two-dimensional figures using coordinates.
- G.11 Understand that a two-dimensional figure is similar to another if the second can be obtained from the first by a sequence of rotations, reflections, translations, and dilations; given two similar two-dimensional figures, describe a sequence that exhibits the similarity between them.

### Process Readiness Indicators Emphasized:

---

- PRI 1: Make sense of problems and persevere in solving through reasoning and exploration.
- PRI 3: Describe and justify mathematical understandings by constructing viable arguments, critiquing the reasoning of others and engaging in meaningful mathematical discourse.
- PRI 5: Use appropriate tools strategically to support thinking and problem solving.
- PRI 6: Attend to precision.
- PRI 7: Look for and make use of patterns and structure.
- PRI 8: Look for and express regularity in repeated reasoning.
- PRI 9: Demonstrate flexible use of strategies and methods while reflecting on which procedures seem to work best for specific types of problems.
- PRI 10: Reflect on mistakes and misconceptions to improve mathematical understanding.

The following *Formative Assessment Lesson* is a classroom-ready lesson included to help teachers assess and improve students' understanding of mathematical concepts and skills and their ability to use the mathematical process readiness indicators critical for college readiness.

Research has shown that formative assessment, as embodied in the following lesson, is a powerful way to improve student learning and performance. This approach first allows students to demonstrate their prior understandings and abilities in employing the mathematical processes, and then resolve their own difficulties and misconceptions through structured discussion. This results in more secure long-term learning, reducing the need for re-teaching that otherwise takes so much classroom time.

Many often ask, why don't students just remember the procedures they have been taught and practiced? The fact is, that approach works fine in the short term but, as every teacher knows, if procedural knowledge is not underpinned by conceptual understanding, students will quickly forget "how to do it."

Read more about the *Formative Assessment Lesson* rationale, structure, and philosophy using the *Brief Guide for Teachers and Administrators* that can be found at <http://map.mathshell.org/materials/index.php>.

Review Copy  
Not for Distribution

---

## CONCEPT DEVELOPMENT

---

Mathematics Assessment Project  
**CLASSROOM CHALLENGES**  
A Formative Assessment Lesson

# Representing and Combining Transformations

Mathematics Assessment Resource Service  
University of Nottingham & UC Berkeley

For more details, visit: <http://map.mathshell.org>  
© 2015 MARS, Shell Center, University of Nottingham  
May be reproduced, unmodified, for non-commercial purposes under the Creative Commons license  
detailed at <http://creativecommons.org/licenses/by-nc-nd/3.0/> - all other rights reserved



## BEFORE THE LESSON

### Assessment task: *Transformations* (15 minutes)

Ask students to complete this task, in class or for homework, a few days before the formative assessment lesson. This will give you an opportunity to assess the work, to find out the kinds of difficulties students have with it. You should then be able to target your help more effectively in the subsequent lesson.

Give each student a copy of the assessment task *Transformations*.

*Read through the questions and try to answer them as carefully as you can.*

It is important that, as far as possible, students are allowed to answer the questions without your assistance.

Students should not worry too much if they cannot understand or do everything, because in the next lesson they will engage in a similar task, which should help them. Explain to students that by the end of the next lesson, they should expect to be able to answer questions like these confidently. This is their goal.

**Transformations**

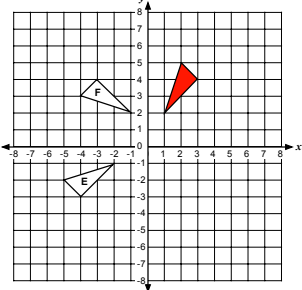

1. Draw the shaded triangle after:

- It has been translated  $-7$  horizontally and  $+1$  vertically. Label your answer A.
- It has been reflected over the  $x$ -axis. Label your answer B.
- It has been rotated  $90^\circ$  clockwise around the origin. Label your answer C.
- It has been reflected over the line  $y = x$ . Label your answer D.

2. Describe fully the single transformation that:

- Takes the shaded triangle onto the triangle labeled E.  
.....  
.....
- Takes the shaded triangle onto the triangle labeled F.  
.....  
.....

### Assessing students' responses

Collect students' responses to the task and make some notes on what their work reveals about their current levels of understanding. The purpose of doing this is to forewarn you of the difficulties students will experience during the lesson itself, so that you may prepare carefully.

We suggest that you do not score students' work. The research shows that this will be counterproductive, as it will encourage students to compare their scores and will distract their attention from what they can do to improve their mathematics.

Instead, help students to make further progress by summarizing their difficulties as a series of questions. Some suggestions for these are given in the *Common issues* table on the next page. These have been drawn from common difficulties observed in trials of this unit.

We suggest you make a list of your own questions, based on your students' work. We recommend you either:

- Write one or two questions on each student's work, or
- Give each student a printed version of your list of questions, and highlight the questions for each individual student.

If you do not have time to do this, you could select a few questions that will be of help to the majority of students and write these on the board when you return the work to the students in the follow-up lesson.

<b>Common issues:</b>	<b>Suggested questions and prompts:</b>
<p><b>Confuses the terms ‘horizontally’ and ‘vertically’</b></p> <p>For example: The student translates the shaded triangle <math>-7</math> units vertically and <math>+1</math> units horizontally in Q1a.</p>	<ul style="list-style-type: none"> <li>Look at the start of the word ‘horizontally’. What are we referring to when we talk about the horizon? Which way is this?</li> </ul>
<p><b>Translates rather than reflect the shape (Q1b)</b></p> <p>For example: The student has translated the shaded triangle vertically <math>-7</math> units and so omitted to draw the mirror image.</p>	<ul style="list-style-type: none"> <li>If you were to place a mirror on the <math>x</math>-axis, what would the reflected image look like?</li> </ul>
<p><b>Confuses the terms ‘clockwise’ and ‘counter clockwise’</b></p> <p>For example: The student rotates the shaded triangle counter clockwise (Q1c.)</p>	<ul style="list-style-type: none"> <li>Think about the direction of the hands on a clock. This direction is ‘clockwise’.</li> </ul>
<p><b>Ignores the center of rotation and rotates from a corner of the shaded triangle</b></p> <p>For example: The student rotates the shaded triangle around the point <math>(1, 2)</math> (Q1d.)</p>	<ul style="list-style-type: none"> <li>Where is the center of rotation?</li> <li>Mark the center of rotation and draw a line to a corner of the shape. Where will this line be once it has been rotated?</li> </ul>
<p><b>Uses an inefficient combination of transformations</b></p> <p>For example: The student describes the transformation in Q2a as “a reflection over the <math>y</math>-axis, followed by a rotation <math>90^\circ</math> counter clockwise around <math>(-1, 2)</math>, followed by a translation <math>-1</math> unit horizontally and <math>-3</math> unit vertically”.</p>	<p>Is there a single transformation that will take the shaded triangle directly to the triangle labeled E?</p>
<p><b>Correctly answers all the questions</b></p> <p>The student needs an extension task.</p>	<ul style="list-style-type: none"> <li>Find a combination of two transformations that could be replaced by a single one.</li> </ul>

## SUGGESTED LESSON OUTLINE

### Whole-class interactive introduction (15 minutes)

Give each student the transparency *L-Shapes* and a pin (to help find centers of rotation).

Using transparencies encourages students to test different transformations. Working dynamically should deepen students' understanding of transformations in a way that simply drawing shapes on a graph does not.

Introduce the lesson by using Slides P-1, P-2, and P-3 of the projector resource.

Ask the students where they think the image of the *L-Shape* will be after it has been translated, reflected, or rotated in different ways:

*Where will the L-Shape be if it is translated  $-2$  units horizontally and  $+1$  units vertically?*

*Where will the L-Shape be if it is reflected over the line  $x = 2$ ?*

*Where will the L-Shape be if it is rotated through  $180^\circ$  around the origin?*

Ask volunteers to demonstrate their answers by placing their grid and *L-Shape* on the overhead projector. Discuss these positions with the rest of the class, and encourage students to challenge their peers if they think the *L-Shape* has been positioned incorrectly.

Once the correct position has been agreed upon, move on to the next transformation.

You may also want to move the *L-Shape* to a different position on the grid, and ask students:

*What transformation will move the L-Shape to this new position? Show me.*

### Collaborative work (30 minutes)

Ask students to work in groups of two or three.

Give each group *Card Set A: Shapes* and *Card Set B: Words* and a copy of the transparency *Transformations*.

*You are now going to continue to transform L-Shapes.*

*You've got six shape cards, each showing a different L-Shape, and eight word cards each of which describes a different transformation.*

Introduce the activity by using Slide P-4 of the projector resource:

#### Matching Cards

1. Take turns to match two shape cards with a word card. Each time you do this, explain your thinking clearly and carefully.
2. Your partner should then either explain that reasoning again in his or her own words, or challenge the reasons you gave.
3. It is important that everyone in the group understands the placing of a word card between two shape cards.
4. Ultimately, you want to make as many links as possible.
5. If possible, use all the shape cards, and all the word the cards.

You may wish display these instructions.

You have two tasks during the paired work: to make a note of student approaches to the task and to support student reasoning.

**Make a note of student approaches to the task**

Listen and watch students carefully. In particular, listen to see whether students are addressing the difficulties they experienced in the assessment. For example, are students having difficulty rotating a shape around  $(2,0)$  or reflecting a shape over the lines  $y = x$  and  $y = -x$ ? You can use information about particular difficulties as a focus for the whole-class discussion later in the lesson.

**Support student reasoning**

Use the questions in the *Common issues* table to help address misconceptions.

Encourage students to explain carefully how they have made each connection.

*Lian, please explain why you've linked these two shapes with this transformation.*

*Laura, can you repeat Lian's explanation in your own words?*

Ask students:

*How does folding the L-Shape along the line of reflection help when reflecting the shape?*

*How does drawing a line from the center of rotation to a corner of the shape help when rotating the shape?*

Students who are struggling should be encouraged to concentrate on linking Shape Cards A, B, C and D.

**Further transformations**

Once students have completed their arrangement of cards, give them a copy of *Card Set C: Additional Words* and a pair of scissors.

Ask students to add an appropriate transformation, where possible, between any shape cards that have not yet been connected.

On completion, students may then glue the cards on a poster. They will need a glue stick and a sheet of large poster paper to do this.

**Extension task**

If a group of students successfully completes the task:

*Can you find a combination of two transformations that could be replaced by a single one?*

*[For example, reflect B over the x-axis B onto A, then reflect A over the y-axis onto C. These two transformations can be replaced by a single transformation: rotate B through 180° around the origin onto C. This can be seen on the example arrangement below.]*

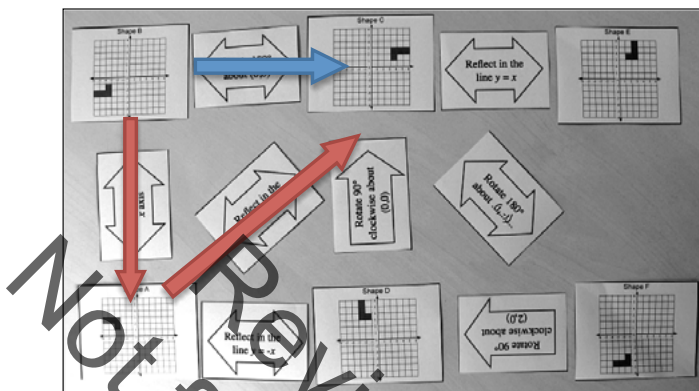

Students should be encouraged to investigate whether or not this is always the case:

*For any shape, will this combination of transformations always replace this single one?*

A proof would involve considering what would happen to the general point  $(x, y)$ . Under a reflection over the  $x$ -axis, this would go to  $(x, -y)$ . After a further reflection over the  $y$ -axis, this would become  $(-x, -y)$ . This is the same as the general point  $(x, y)$  being rotated through  $180^\circ$  around the origin.

Students should be encouraged to look for other possible combinations in their card arrangements in the same way.

**Whole-class discussion (15 minutes)**

Give either a mini-whiteboard, pen, and eraser, or a piece of squared paper to each group of students.

Use Slides P-5 and P-6 of the projector resource to support a whole-class discussion.

Ask students to do the following transformations using the coordinate grid on the transparency *Transformations*, then to write the new coordinate on their mini-whiteboard:

*Use the transparency Transformations. Mark the coordinate  $(1, 4)$  on the coordinate grid.*

*Show me the new coordinates of the point  $(1, 4)$  after it is:*

- *Reflected over the  $x$ -axis.*  $(1, -4)$
- *Reflected over the  $y$ -axis.*  $(-1, 4)$
- *Rotated through  $180^\circ$  around the origin.*  $(-1, -4)$
- *Reflected over the line  $y = x$ .*  $(4, 1)$
- *Reflected over the line  $y = -x$ .*  $(-4, -1)$
- *Rotated through  $90^\circ$  clockwise around the origin.*  $(4, -1)$
- *Rotated through  $90^\circ$  counterclockwise around the origin.*  $(-4, 1)$

You may like to repeat this with a general starting point  $(x, y)$ .

*Show me the new coordinates of the general point  $(x, y)$  after it is:*

- Reflected over the  $x$ -axis.  $(x, -y)$
- Reflected over the  $y$ -axis.  $(-x, y)$
- Rotated through  $180^\circ$  around the origin.  $(-x, -y)$
- Reflected over the line  $y = x$ .  $(y, x)$
- Reflected over the line  $y = -x$ .  $(-y, -x)$
- Rotated through  $90^\circ$  clockwise around the origin.  $(y, -x)$
- Rotated through  $90^\circ$  counterclockwise around the origin.  $(-y, x)$

It may be helpful to write the new coordinates on the board, to be able to extend discussions to include combinations of transformations:

*What is the single transformation that will produce the same result as:*

- *A rotation of  $90^\circ$  clockwise around the origin, followed by a reflection in the  $y$ -axis?*

*[This is a reflection in the line  $y = -x$ .]*

*Show me two transformations that can be written as a single transformation.*

*Show me two transformations that cannot be written as a single transformation. Can you change the starting point of the shape so that it can be written as a single transformation?*

**Follow-up lesson: improving individual solutions to the assessment task (10 minutes)**

Return their original assessment task *Transformations* to the students, together with a blank copy of the task.

*Look at your original responses and think about what you have learned this lesson.*

*Using what you have learned, try to improve your work.*

If you have not added questions to individual pieces of work then write your list of questions on the board. Students should select from this list only those questions they think are appropriate to their own work.

Some teachers give this for homework.

**SOLUTIONS**

**Assessment Task: Transformations**

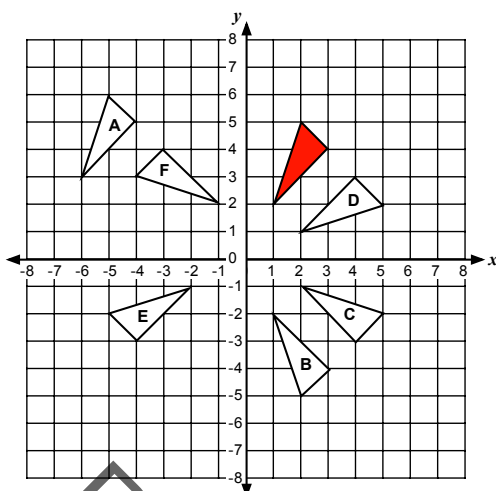

- 2a. Reflection over the line  $y = -x$ .      2b. Rotation  $90^\circ$  counterclockwise around  $(0, 1)$ .  
 3. Reflection over the line  $y = x$ .

**Collaborative work**

The following connections exist between pairs of shape cards:

Pairs of shapes	Transformation	Pairs of shapes	Transformation
A onto B	Reflection over the $x$ -axis.	B onto F	Translation +2 units horizontally and -2 units vertically.
F onto D	Clockwise rotation of $90^\circ$ around $(2, 0)$ .	D onto E	Reflection over the $y$ -axis.
E onto C	Reflection over the line $y = x$ .	C onto A	Reflection over the $y$ -axis.
A onto D	Reflection over the line $y = -x$ .	C onto B	Rotation of $180^\circ$ around the origin.
A onto E	Clockwise rotation of $90^\circ$ around the origin.	B onto D	Clockwise rotation of $90^\circ$ around the origin.
D onto C	Clockwise rotation of $90^\circ$ around the origin.	B onto E	Reflection over the line $y = -x$ .

## Transformations

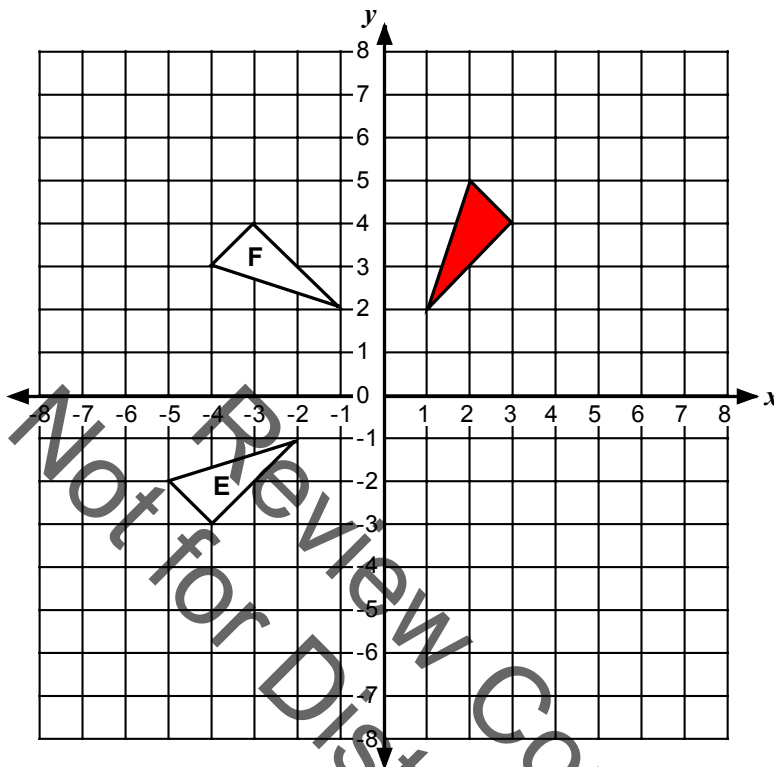

1. Draw the shaded triangle after:
  - a) It has been translated  $-7$  horizontally and  $+1$  vertically. Label your answer *A*.
  - b) It has been reflected over the  $x$ -axis. Label your answer *B*.
  - c) It has been rotated  $90^\circ$  clockwise around the origin. Label your answer *C*.
  - d) It has been reflected over the line  $y = x$ . Label your answer *D*.
  
2. Describe fully the single transformation that:
  - a) Takes the shaded triangle onto the triangle labeled *E*.

.....

.....

.....

- b) Takes the shaded triangle onto the triangle labeled *F*.

.....

.....

.....



3. Describe a single transformation that has the same effect as rotating a shape  $90^\circ$  clockwise around the origin, then reflecting the result over the  $x$ -axis.

---

---

---

Review Copy  
Not for Distribution

## Transparency: L-Shapes

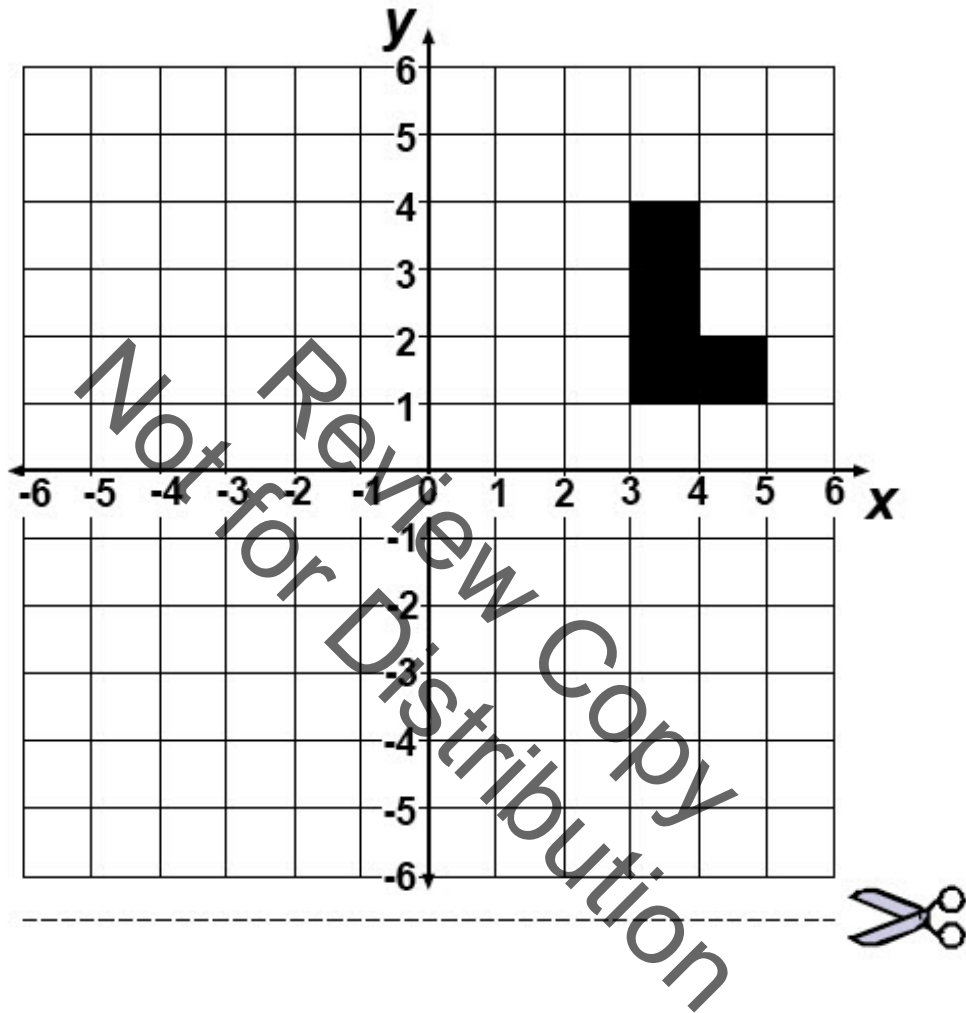

## Transparency: Transformations

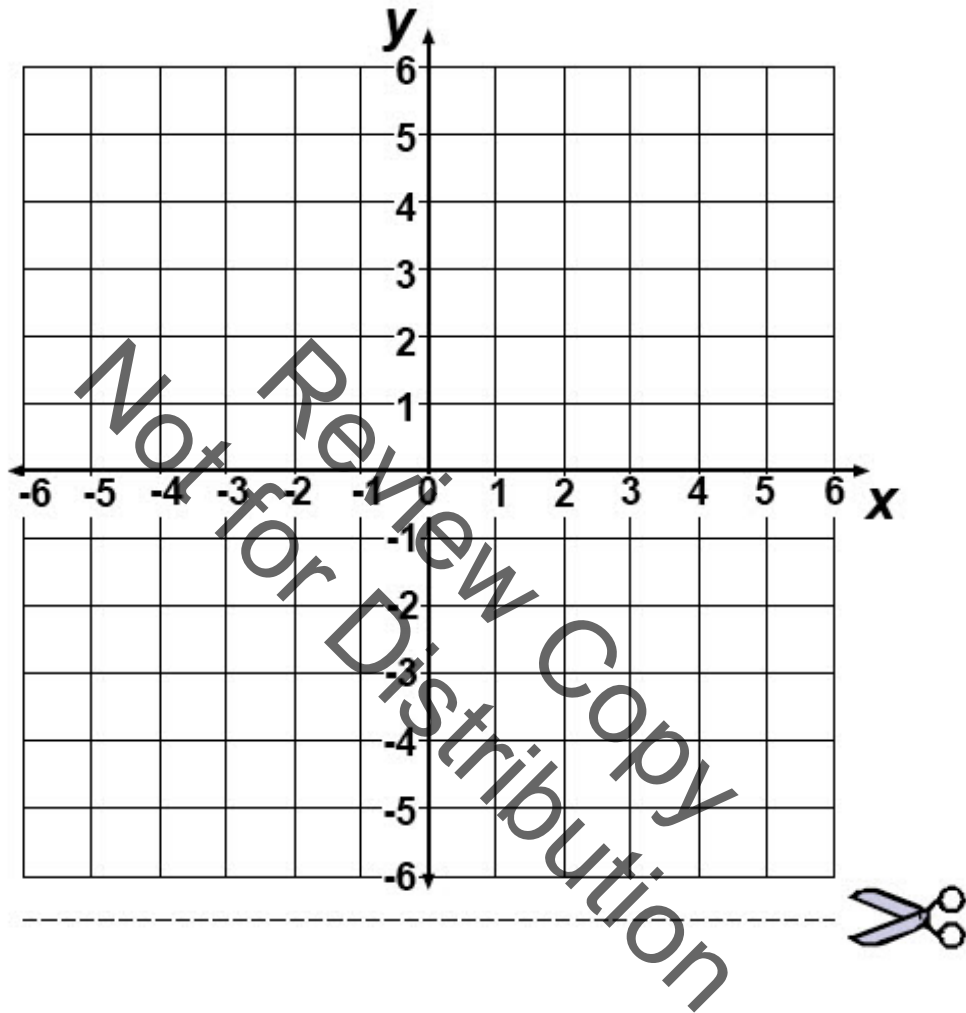

### Card Set A: Shapes

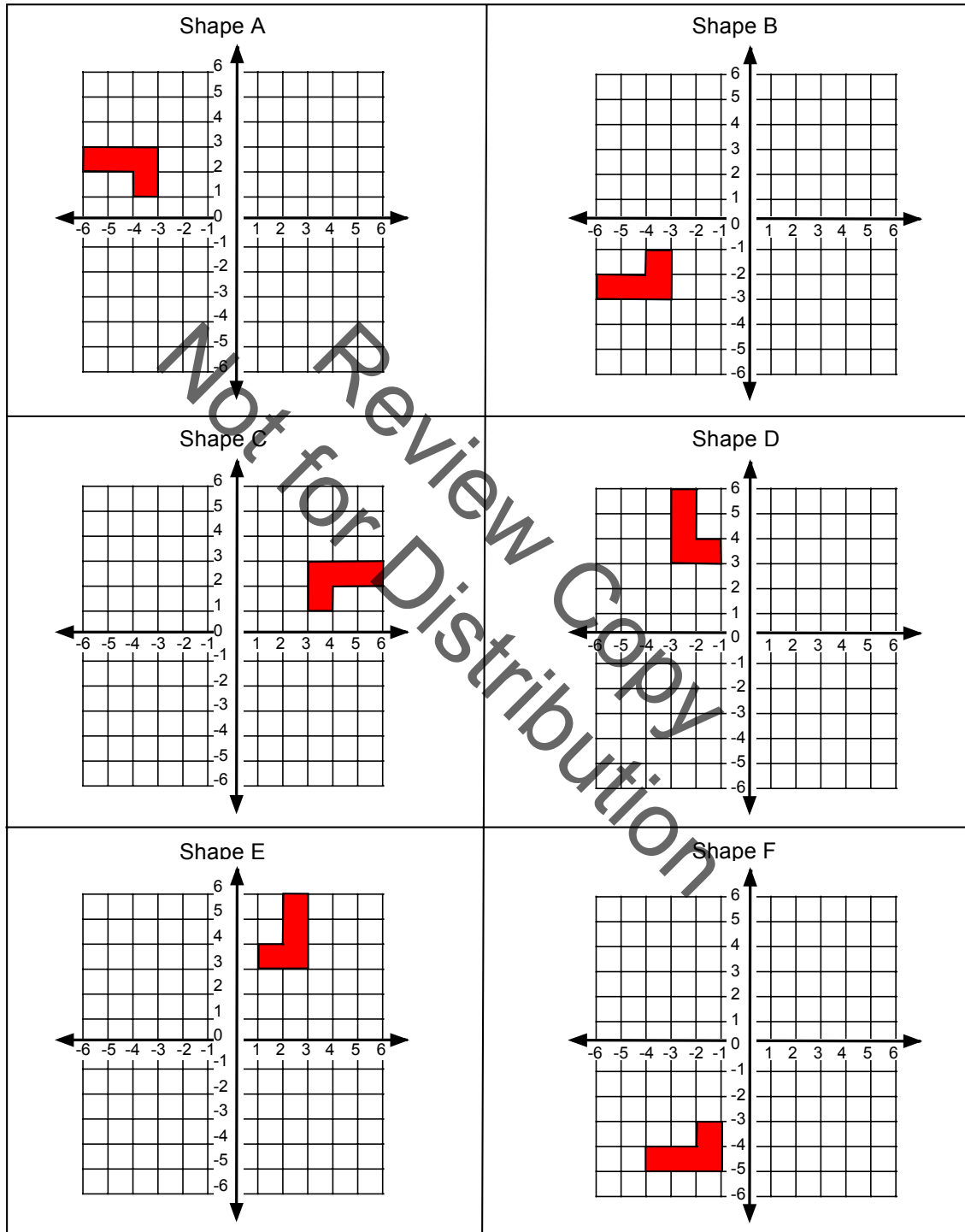

### Card Set B: Words

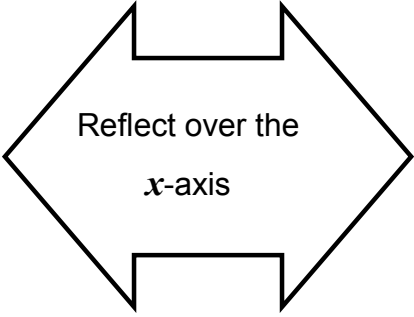
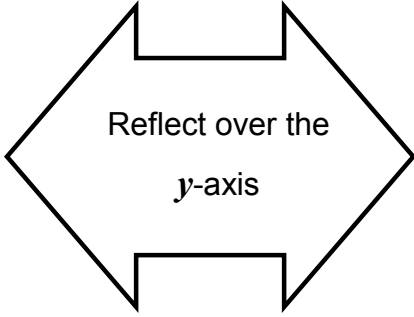
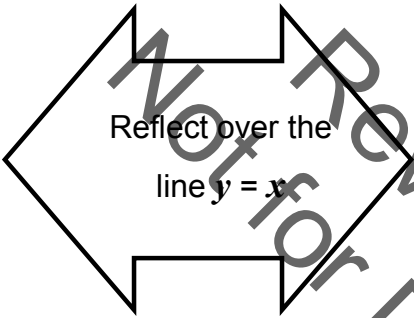
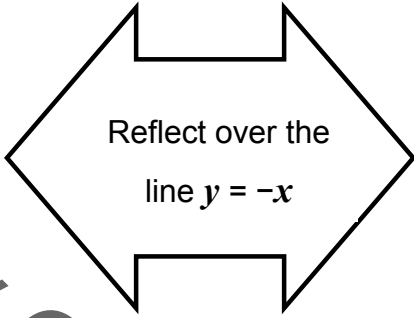
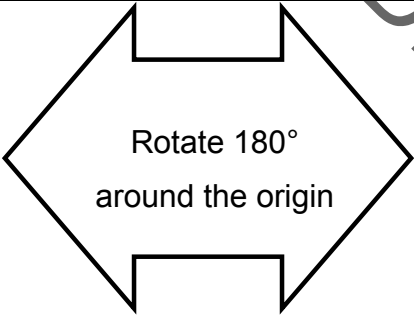
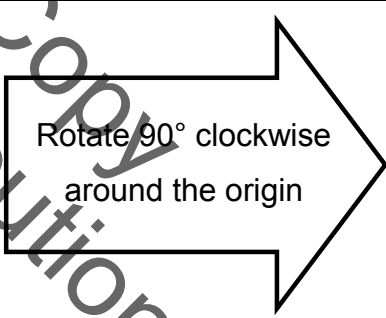
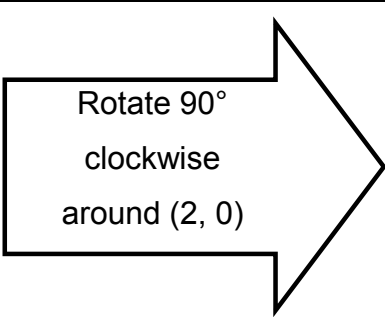
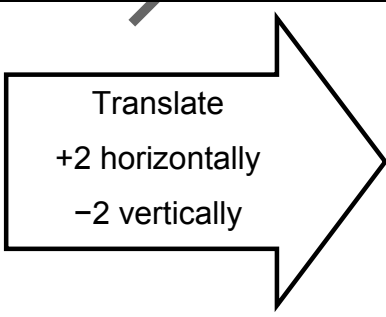
 <p>Reflect over the <math>x</math>-axis</p>	 <p>Reflect over the <math>y</math>-axis</p>
 <p>Reflect over the line <math>y = x</math></p>	 <p>Reflect over the line <math>y = -x</math></p>
 <p>Rotate <math>180^\circ</math> around the origin</p>	 <p>Rotate <math>90^\circ</math> clockwise around the origin</p>
 <p>Rotate <math>90^\circ</math> clockwise around <math>(2, 0)</math></p>	 <p>Translate <math>+2</math> horizontally <math>-2</math> vertically</p>

### Card Set C: Additional Words

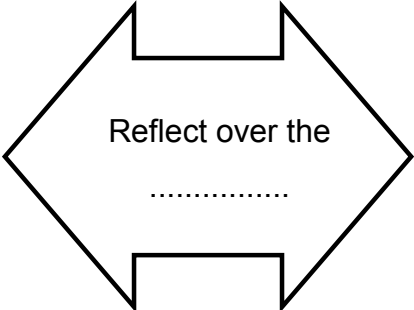
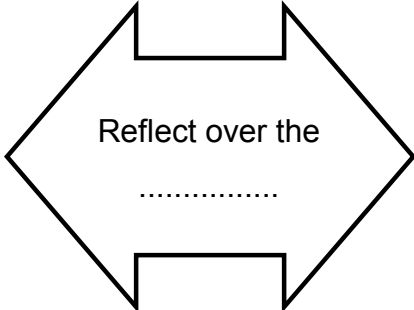
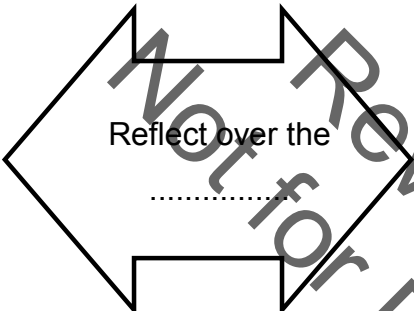
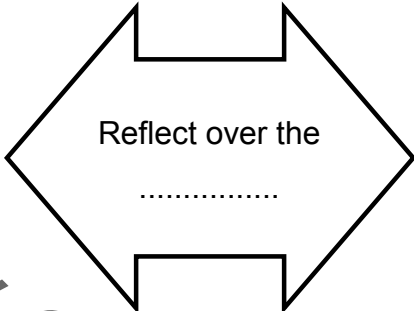
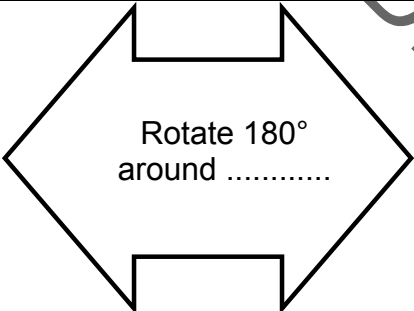
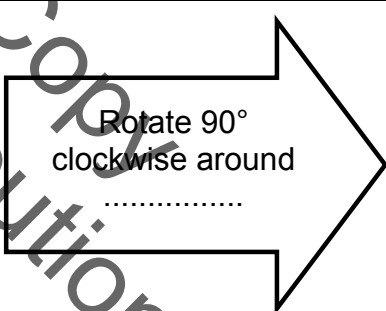
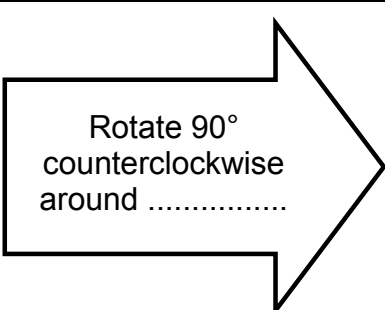
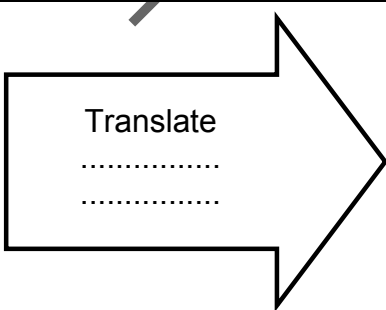
 <p>Reflect over the .....</p>	 <p>Reflect over the .....</p>
 <p>Reflect over the .....</p>	 <p>Reflect over the .....</p>
 <p>Rotate 180° around .....</p>	 <p>Rotate 90° clockwise around .....</p>
 <p>Rotate 90° counterclockwise around .....</p>	 <p>Translate ..... .....</p>

# Translation

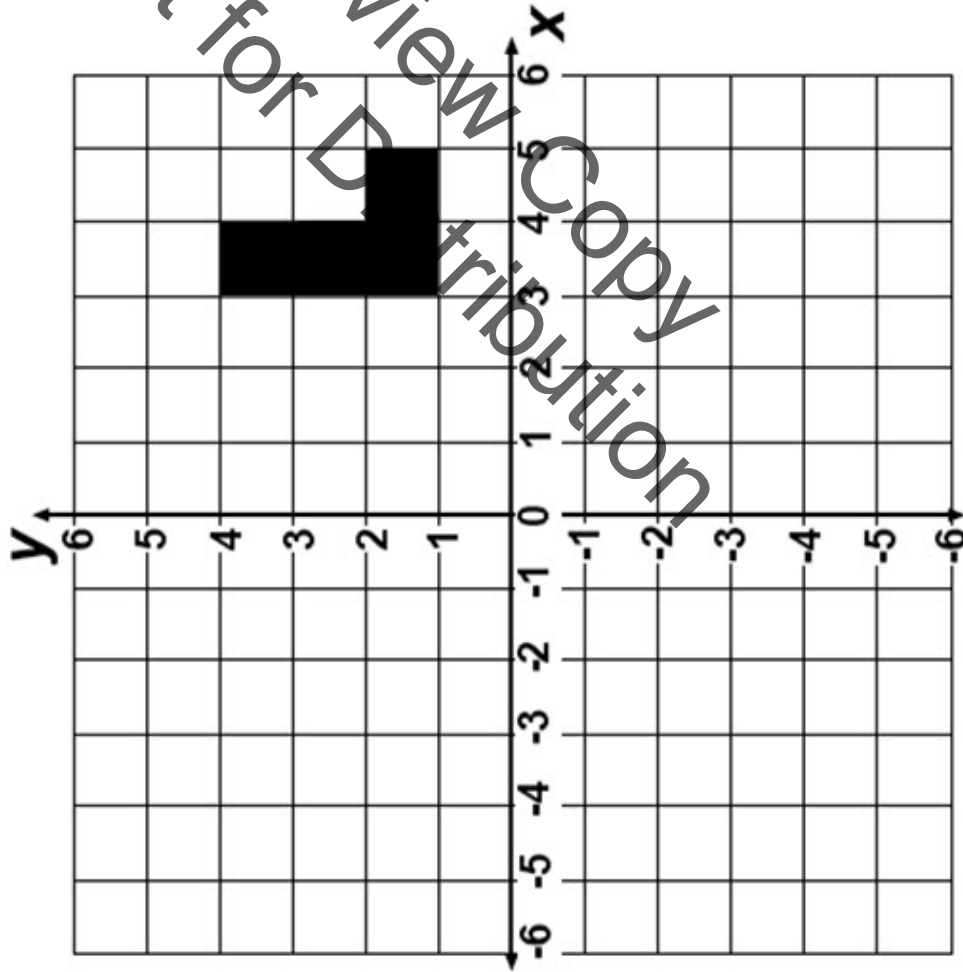

Where will the L-shape be if it is translated by  $-2$  horizontally and  $+1$  vertically?

# Reflection

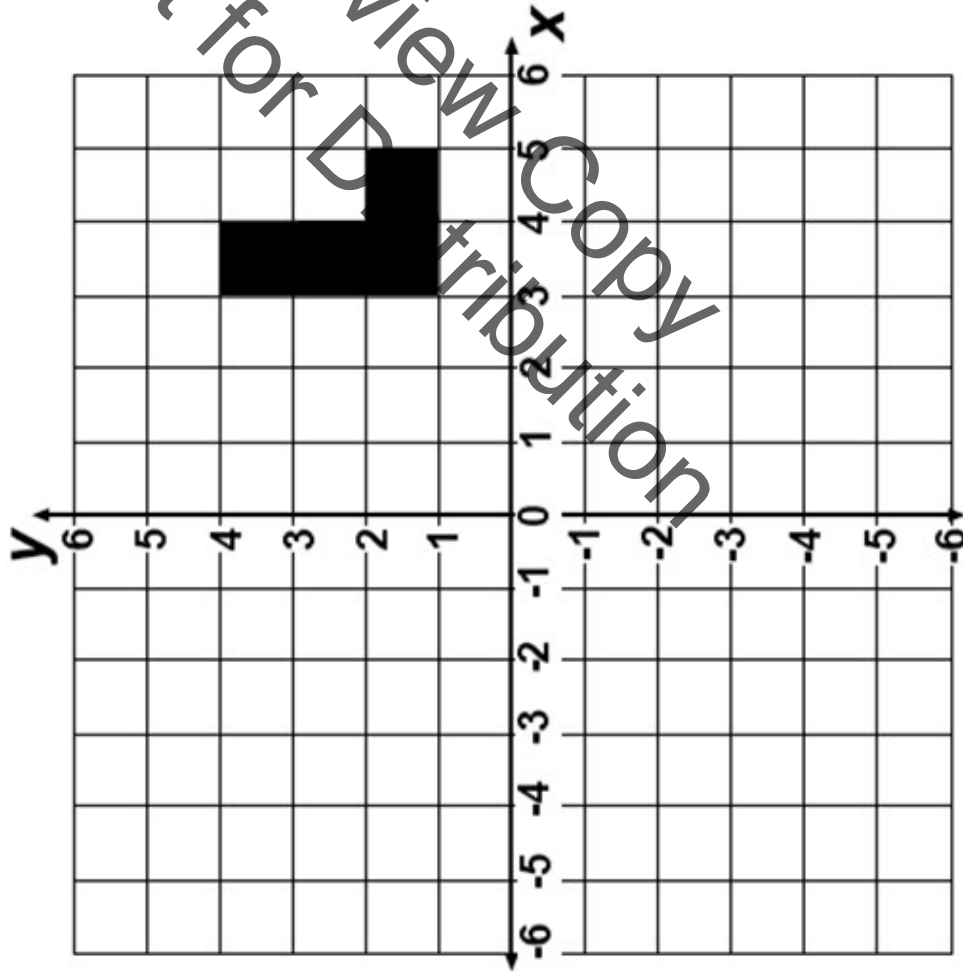

Where will the  
L-shape be if it is  
reflected over the  
line  $x = 2$ ?



# Rotation

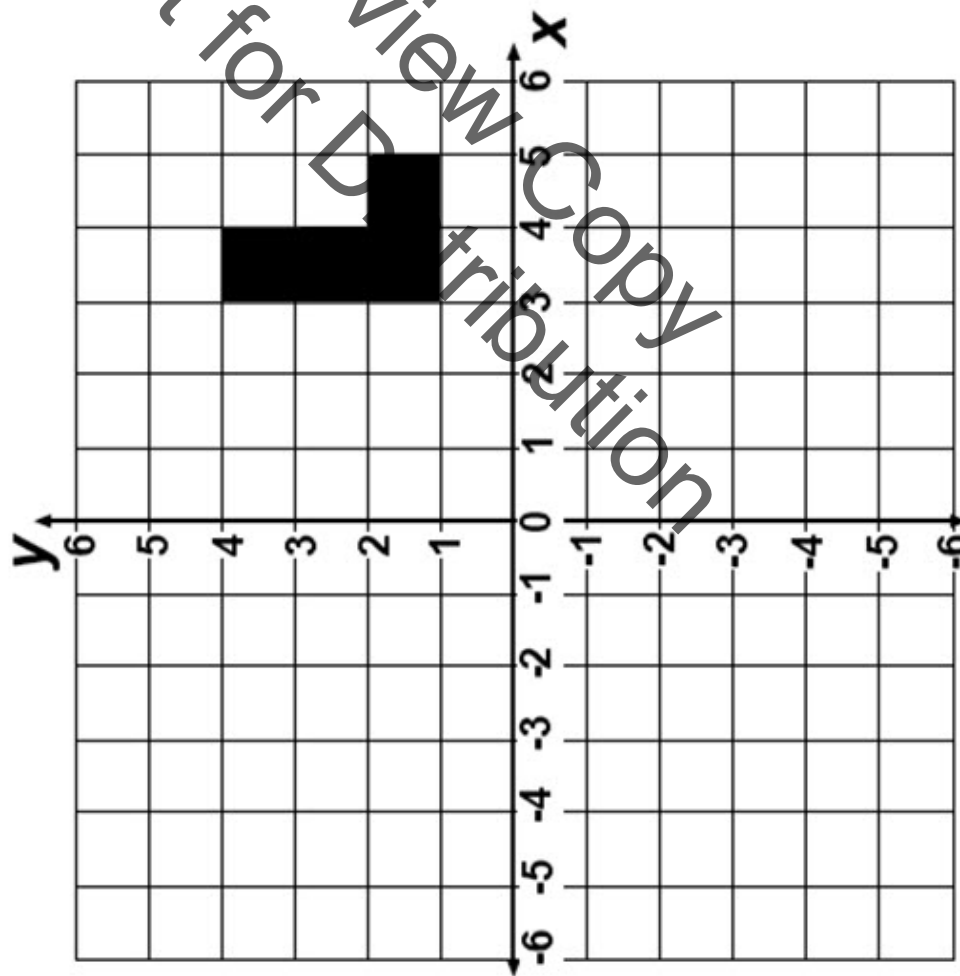

Where will the L-shape be if it is rotated through  $180^\circ$  around the origin?

## Matching Cards

1. Take turns to match two shape cards with a word card. Each time you do this, explain your thinking clearly and carefully.
2. Your partner should then either explain that reasoning again in his or her own words, or challenge the reasons you gave.
3. It is important that everyone in the group understands the placing of a word card between two shape cards .
4. Ultimately, you want to make as many links as possible.
5. If possible, use all the shape cards, and all the word cards.

## Starting point (1, 4)

Show me the new coordinates of the point (1, 4) after it is:

- Reflected over the  $x$ -axis
- Reflected over the  $y$ -axis
- Rotated through  $180^\circ$  about the origin.
- Reflected over the line  $y = x$ .
- Reflected over the line  $y = -x$ .
- Rotated through  $90^\circ$  clockwise about the origin.
- Rotated through  $90^\circ$  counterclockwise about the origin.

## General starting point $(x, y)$

Show me the new coordinates of the point  $(x, y)$  after it is:

- Reflected over the  $x$ -axis
- Reflected over the  $y$ -axis
- Rotated through  $180^\circ$  about the origin.
- Reflected over the line  $y = x$ .
- Reflected over the line  $y = -x$ .
- Rotated through  $90^\circ$  clockwise about the origin.
- Rotated through  $90^\circ$  counterclockwise about the origin.

## Mathematics Assessment Project **Classroom Challenges**

These materials were designed and developed by the  
Shell Center Team at the Center for Research in Mathematical Education  
University of Nottingham, England:

**Malcolm Swan,**  
**Nichola Clarke, Clare Dawson, Sheila Evans, Colin Foster, and Marie Joubert**  
with  
**Hugh Burkhardt, Rita Crust, Andy Noyes, and Daniel Pead**

We are grateful to the many teachers and students, in the UK and the US,  
who took part in the classroom trials that played a critical role in developing these materials

The classroom observation teams in the US were led by  
**David Foster, Mary Bouck, and Diane Schaefer**

This project was conceived and directed for  
The Mathematics Assessment Resource Service (MARS) by  
**Alan Schoenfeld** at the University of California, Berkeley, and  
**Hugh Burkhardt, Daniel Pead, and Malcolm Swan** at the University of Nottingham

Thanks also to Mat Crosier, Anne Floyd, Michael Galan, Judith Mills, Nick Orchard, and Alvaro Villanueva who contributed to the design and production of these materials

This development would not have been possible without the support of  
**Bill & Melinda Gates Foundation**

We are particularly grateful to  
**Carina Wong, Melissa Chabran, and Jamie McKee**

The full collection of Mathematics Assessment Project materials is available from

<http://map.mathshell.org>

© 2015 MARS, Shell Center, University of Nottingham  
This material may be reproduced and distributed, without modification, for non-commercial purposes,  
under the Creative Commons License detailed at <http://creativecommons.org/licenses/by-nc-nd/3.0/>  
All other rights reserved.

Please contact [map.info@mathshell.org](mailto:map.info@mathshell.org) if this license does not meet your needs.

## Geometry

# Lesson 9 of 9

## Pythagorean Theorem/Distance Formula

### Description:

---

Students studied triangles in lesson 3. In this lesson, they will concentrate on right triangles. Using computers and an applet, the students will be introduced to the Pythagorean Theorem. They will learn and discover how the theorem works. They will go through the applet and answer the explore questions with their team. Once the students have a good grasp on the Pythagorean Theorem they will apply their knowledge through the Pythagorean Crime Stoppers activity. This lesson will provide opportunities for students to use their skills and reasoning to solve real world problems. Through this experience they may gain a deeper understanding and appreciation for the application of mathematical properties modeling real-world situations that allow for strong student connections. Students will learn how to analyze data, recognize and figure out patterns and create a model for the data.

### College- and Career-Readiness Standards Addressed:

---

- G.11 Explain a proof of the Pythagorean Theorem and its converse
- G.12 Apply the Pythagorean Theorem to determine unknown side lengths in right triangles in real world and mathematical problems in two and three dimensions.

### Process Readiness Indicators Emphasized:

---

- PR1: Make sense of problems and persevere in solving through reasoning and explanation
- PR2: Reason abstractly and quantitatively by using multiple forms of representation to make sense of and understand mathematics
- PR3: Describe and justify mathematical understandings by constructing viable arguments, critiquing the reasoning of others and engaging in meaningful mathematical discourse
- PR4: Model with mathematics

Sequence of Instruction

Activities Checklist

Engage

PRI 1  
PRI 2

**Commentary for the Teacher:** We recommend grouping students by like abilities and with a group of two to four students each. This will allow the students to work at their own level and to be an active participant in the learning process.

Students will begin by making sense of problems and persevering in solving them through reasoning and explanation. Each student group will need a computer, ipad, chromebook, etc. Explain to the students that they will be using the Squaring the Triangle applet to look for patterns in the area of the squares.

**Commentary for the Teacher:** If students do not have a 1-to-1 digital device, teachers can display this module using a projector and allow student volunteers to interact with the module.

Direct students to the Task #29: Squaring the Triangles activity in the student manual. In your groups discuss and answer the following questions:

- What defines a right triangle?
- How do you find the area of a square?
- How are the angles and the sides opposite of them related?

INCLUDED IN THE STUDENT MANUAL

**Task #29: Squaring the Triangles**

1. What defines a right triangle?

---

---

2. What is the area of a square?

---

---

3. How are the angles and the sides opposite them related?

---

---

Then have the students go to the following website: <http://www.shodor.org/interactivate/activities/SquaringTheTriangle/>

Students will reason abstractly and quantitatively by using the applet to help them make sense of and understand mathematics. In the groups students will complete the discovery part of the Task #29: Squaring the Triangles.

INCLUDED IN THE STUDENT MANUAL

4. How are the blue squares related?

---

5. How are the two non-right angles related?

---

6. How are the sides related in a right triangle?

---

Have the students come back as a whole group and share out what patterns they noticed within the activity.

## Explore

### PRI 2

Display picture of a right triangle on the board. Explain to the students what each part of the triangle is and means. The most important part of the right triangle to explain is the hypotenuse. Students will then in their groups reason abstractly and quantitatively by using what they learned in the engage section to answer the next questions in Pythagorean Explorer.

- How do you determine what side of the triangle is the hypotenuse?
- What is true of all hypotenuses, compared to the other sides?
- How would you estimate your values so you could avoid using a calculator?

## Explanation

Take the explore questions from Task #29, Squaring a Triangle to explain what the Pythagorean Theorem is. The students should have discovered that the area from the square of A and the area of the square of B equaled the area of the square of C. At this point show the students the algorithm of Pythagorean Theorem. Have them use the knowledge of the algorithm and practice it using the applet. <http://www.shodor.org/interactivate/activities/PythagoreanExplorer/>

**Commentary for the Teacher:** *If the students are having difficulty at first you might want to do a Level 1 together with the class to model how to use the theorem.*

## Practice Together / in Small Groups / Individually

### PRI 3 PRI 4

Students will now apply their knowledge of Pythagorean Theorem to solve various real world problems.

Read Scenario 1 to the class (Task #30 in the Student Manual).

Note to teachers: The following activity is adapted from the Crime Scene Investigation found at: <http://www.radford.edu/rumath-smpdc/Units/src/The%20Pythagorean%20Theorem%20in%20Crime%20Scene%20Investigation.pdf>



It is Monday morning and you and your partner have been selected by the local police force to assist on a case while the police force is short staffed due to the flu. A janitor at the local art museum arrived to work this morning only to discover the door was unlocked, valuable artifacts were missing and the curator is nowhere to be seen and cannot be reached.

This is the information you are given:

1. The curator is not at the museum or at home, and hasn't been seen or heard from since Friday.
2. The curator walks to and from work every day (see Map1), stopping to get coffee every morning at the Coffee House, and stopping for dinner every night at the Cafe.
3. Every day, the curator has lunch at the Deli.
4. The curator's keys are also missing.

Break the students into groups of two. Each group will have their own map (a copy of this can be found at the end of this lesson), scenario and an investigation sheet. The investigation sheet will contain questions to guide students towards finding the area of right triangles, and the length of the hypotenuse. The final question on the investigation sheet will ask students to determine the total area to be searched, if a search for a missing person were conducted using the map and story provided.

Have the class come back to whole group to share their group's' results and encourage students to clearly explain their reasoning. Have student groups take turns presenting their answers to the questions on the investigation sheet, drawing their triangles on the board. Have the class discuss reasons for differences between groups. The class should also discuss why someone might choose to not travel by foot along the hypotenuse of a triangle on the map.

**Commentary for the Teacher:** To facilitate learning, teachers should encourage the students to draw a picture to work through problem solving steps. They should write down ideas and the facts they are sure of and consider what they do not know but need to find out.

*Students might have misconceptions with calculating the distance between the museum and the curator's house; they may be too focused on the route the curator walked to the museum instead of finding the hypotenuse of the triangle formed by his path.*

## Evaluate Understanding

**PRI 3**  
**PRI 4**

Read the following scenario to engage the students and elicit initial responses and ideas, which they would write down and keep to themselves for the sake of preserving other students' self discovery.

There has been a break in at the local museum. Valuable artifacts have been stolen. Two windows have been breached and it is suspected that the perpetrator used a very tall ladder to enter or leave the museum through these windows. The authorities are hoping that learning more about this unusual ladder will provide clues to identify a suspect. Near the first window, two indentations were found on the ground 16 feet away from the base of the building. It is suspected that the feet of a ladder created these indentations. The first breached window is 30 feet high off of the ground. Investigators need to

determine approximately how tall the ladder was. Solicit responses before the first task is presented: “Has anyone ever seen a ladder that tall? Are they common? What else may be involved with this scenario? Are there other ideas or things to consider? Jot down your possible answers to these and other questions you may have.

INCLUDED IN THE STUDENT MANUAL

**Task #30: Scenario One**

There has been a break in at the local museum. Valuable artifacts have been stolen. Two windows have been breached and it is suspected that the perpetrator used a very tall ladder to enter or leave the museum through these windows. The authorities are hoping that learning more about this unusual ladder will provide clues to identify a suspect. Near the first window, two indentations were found on the ground 16 feet away from the base of the building. It is suspected that the feet of a ladder created these indentations. The first breached window is 30 feet high off of the ground. Investigators need to determine approximately how tall the ladder was.

Have you ever seen a ladder that tall?

---

Are they common?

---

What else may be involved with this scenario?

---

---

Are there other ideas or things to consider?

---

---

Jot down other questions you may have.

---

---

---

---

---

---

---

**Commentary for the Teacher:** To facilitate learning, teachers should encourage the students to draw a picture to work through problem solving steps. They should write down ideas and the facts they are sure of and consider what they do not know but need to find out.

Students might have misconceptions with calculating the distance between the museum and the curator's house; they may be too focused on the route the curator walked to the museum instead of finding the hypotenuse of the triangle formed by his path.

Students will work individually on the first part of this scenario.

**Task #30: contd.**

**Task #1:** Use this information to sketch and label a diagram of the crime scene and find the length of the suspected ladder used.

**Assumption #1:** It is assumed that the wall of the building is "plumb" and rises perpendicular to the ground.

Why do you think this assumption is given? State what makes it relevant to the scenario.

---

---

---

---

---

In groups of 2, students will collaborate to shares notes and results and verify solutions. Partners will then collaborate to work through the next step of this case.

INCLUDED IN THE STUDENT MANUAL

**Task #31: Scenario Two**

Investigators have determined that the second window breached at the museum was 33 feet off of the ground. No obvious indentations were found on the ground near the second window and we are not quite sure yet where the foot of the ladder was located.

**Task #2:** Use this information to sketch and label a diagram of the crime scene and consider the length of the suspected

**Task #3:** Based on the same assumption as before, discuss the circumstances with your partner, then individually answer the following questions on your paper:

Is it possible that the same ladder was used to breach the second window?

\_\_\_\_\_

If not, explain your reasoning.

\_\_\_\_\_

If so, approximately where on the ground could we look for evidence of the where the ladder was based? (Your answer should be expressed in feet and inches.)

\_\_\_\_\_

How could this information possibly lead us to conclusions about the suspect entering and exiting the museum?

\_\_\_\_\_

\_\_\_\_\_

\_\_\_\_\_

\_\_\_\_\_

## Closing Activity

To close the activity have each student pairs take a few minutes to sketch their crime scene on the board and demonstrate how they solved their tasks and discuss their findings of the case so far.

INCLUDED IN THE STUDENT MANUAL

### Task #32: Lesson 9 Reflection

1. Summarize what you learned in this lesson.

---

---

2. How is this skill helpful in the real-world? Explain.

---

---

## Independent Practice:

Students will complete the Task #33: Scenario 3 as independent practice or it could be given as a homework assignment.

INCLUDED IN THE STUDENT MANUAL

### Task #33: Scenario Three

The authorities have received an anonymous phone call. The caller left the following information: The curator was seen getting into a vehicle immediately after leaving the coffee shop where he got his morning coffee, but before he got to the museum.

After being picked up, the vehicle drove three blocks, turned left, drove another four blocks, and then stopped. The curator is still alive. The caller refused to give any further detail and hung up immediately after relaying this information. The authorities want you to remember that the curator has not been seen since disappearing.

Looking at the map, locate possible places as to where this holding place might be located. Also, using the coffee shop as a starting point, determine the area in which this location could be. Answer the questions on the investigation sheet.

## Resources/Instructional Materials Needed:

Additional resource for students to use Pythagorean Theorem on a coordinate plane:  
<http://www.shodor.org/interactivate/activities/TriangleExplorer/>

Crime Scene Investigation:

<http://www.radford.edu/rumath-smpdc/Units/src/The%20Pythagorean%20Theorem%20in%20Crime%20Scene%20Investigation.pdf>

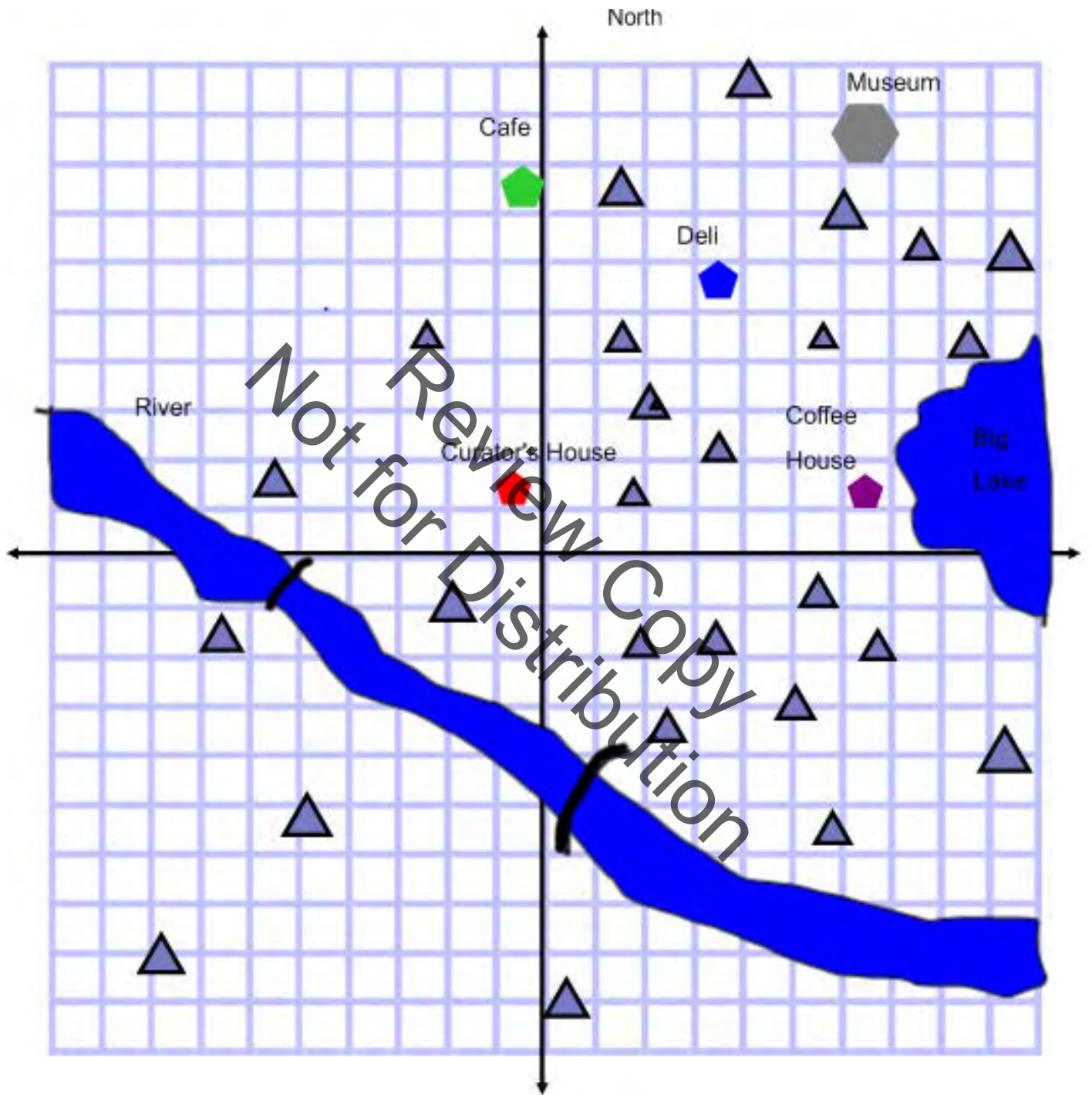

## Materials

---

Needed Digital device  
Task #29: Squaring the Triangles  
Task #30: Scenario 1”  
Task #31: Scenario 2”  
Task #32: Reflection on Lesson 9

## Notes:

---

At some point in this lesson lead the students back to Lesson 1 at the beginning of the geometry unit. Have them remember when they worked on the diagonal method and traditional method of wrapping a present and ask them how the Pythagorean Theorem could help them now solve the problem. Have them go back to the problem in the student manual and use the Pythagorean Theorem to work the *Let's Experiment* problem.

Review Copy  
Not for Distribution

# SREB

## SREB Readiness Courses

# Ready for High School: Math

### Math Unit 6

### Functions and Linear Relationships

Not for Review Copy Distribution

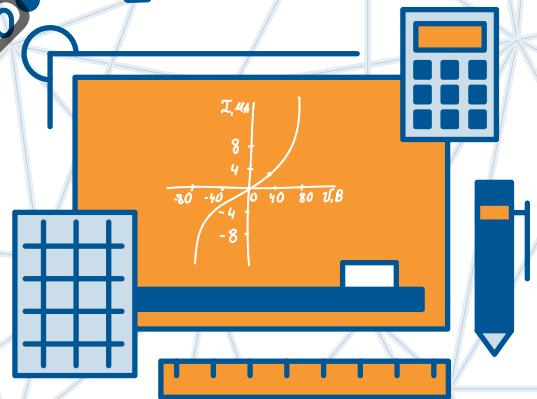
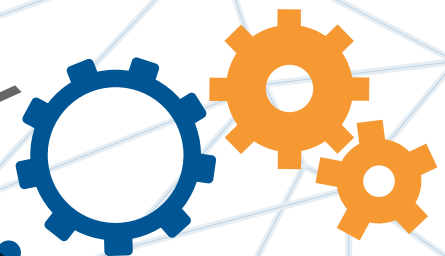

Southern  
Regional  
Education  
Board

592 Tenth Street, NW  
Atlanta, GA 30318  
(404) 875-9211

[www.sreb.org](http://www.sreb.org)



## Unit 6 . Functions and Linear Relationships

### Overview

In this unit, students will identify the characteristics that distinguish functions from relations and will identify functions as linear or non-linear. Students will investigate linear relationships in depth through tables, equations, and graphs. Students will develop linear models for real – world situations. Students will relate slope as a rate of change and the y-intercept contextually to real – world problems.

### Essential Questions:

---

- *How do you use functions to model relationships between quantities?*
- *How do you define, evaluate, and compare functions?*
- *How do I know if a function is linear or nonlinear?*
- *In what ways can we compare two different linear relationships?*
- *How do you use the slope formula?*
- *How is the equation of a line derived?*
- *How can you interpret slope and y-intercept in the context of a problem?*

## College- and Career-Readiness Standards:

---

Analyze proportional relationships and use them to solve real-world and mathematical problems.

- RP.5 Recognize and represent proportional relationships between quantities.

Define, evaluate, and compare functions.

- F.1 Understand that a function is a rule that assigns to each input exactly one output. The graph of a function is the set of ordered pairs consisting of an input and the corresponding output.
- F.2 Compare properties of two functions each represented in a different way (algebraically, graphically, numerically in tables, or by verbal descriptions). For example, given a linear function represented by a table of values and a linear function represented by an algebraic expression, determine which function has the greater rate of change.
- F.3 Interpret the equation  $ax + b = c$  as defining a linear function, whose graph is a straight line; give examples of functions that are not linear. For example, the function giving the area of a square as a function of its side length is not linear because its graph contains the points (1, 1), (2, 4) and (3, 9), which are not on a straight line.

Use functions to model relationships between quantities.

- F.4 Construct a function to model a linear relationship between two quantities. Determine the rate of change and initial value of the function from a description of a relationship or from two (x, y) values, including reading these from a table or from a graph. Interpret the rate of change and initial value of a linear function in terms of the situation it models, and in terms of its graph or a table of values.
- F.5 Describe qualitatively the functional relationship between two quantities by analyzing a graph (e.g., where the function is increasing or decreasing, linear or nonlinear). Sketch a graph that exhibits the qualitative features of a function that has been described verbally.

Investigate patterns of association in bivariate data.

- SP.13 Construct and interpret scatter plots for bivariate measurement data to investigate patterns of association between two quantities. Describe patterns such as clustering, outliers, positive or negative association, linear association, and nonlinear association.
- SP.14 Know that straight lines are widely used to model relationships between two quantitative variables. For scatter plots that suggest a linear association, informally fit a straight line, and informally assess the model fit by judging the closeness of the data points to the line.
- SP.15 Use the equation of a linear model to solve problems in the context of bivariate measurement data, interpreting the slope and intercept. For example, in a linear model for a biology experiment, interpret a slope of 1.5 cm/hr as meaning that an additional hour of sunlight each day is associated with an additional 1.5 cm in mature plant height.

## Prior Scaffolding Knowledge / Skills:

---

Represent and analyze quantitative relationships between dependent and independent variables.

- Use variables to represent two quantities in a real-world problem that change in relationship to one another; write an equation to express one quantity, thought of as the dependent variable, in terms of the other quantity, thought of as the independent variable. Analyze the relationship between the dependent and independent variables using graphs and tables, and relate these to the equation.

Analyze proportional relationships and use them to solve real-world and mathematical problems.

- Recognize and represent proportional relationships between quantities.
- Decide whether two quantities are in a proportional relationship, e.g., by testing for equivalent ratios in a table or graphing on a coordinate plane and observing whether the graph is a straight line through the origin.
- Identify the constant of proportionality (unit rate) in tables, graphs, equations, diagrams, and verbal descriptions of proportional relationships.
- Represent proportional relationships by equations.
- Explain what a point  $(x, y)$  on the graph of a proportional relationship means in terms of the situation, with special attention to the points  $(0, 0)$  and  $(1, r)$  where  $r$  is the unit rate.

Understand the connections between proportional relationships, lines, and linear equations.

- Graph proportional relationships. Interpreting the unit rate as the slope of the graph. Compare two different proportional relationships represented in different ways. *For example, compare a distance-time graph to a distance-time equation to determine which of two moving objects has greater speed.*
- Use similar triangles to explain why the slope  $m$  is the same between any two distinct points on a non-vertical line in the coordinate plane; derive the equation  $y = mx$  for a line through the origin and the equation  $y = mx + b$  for a line intercepting the vertical axis at  $b$ .

### Lesson Progression Overview:

Lesson Big Idea	Lesson Details	Content Standards	Process Readiness Indicators
<b>Lesson 1: What makes a relation a function?</b>	(This lesson will begin with the unit hook which serves to informally assess students' understanding of linear functions.)  In this lesson, students will distinguish between relations that are functions and those that are not. The relations will be represented in multiple ways. Students will be expected to justify their conclusions.	F.1	PRI 3 PRI 7
<b>Lesson 2: Linear and Nonlinear Functions</b>	Students will examine functions in the form of tables, graphs, and equations to determine if they represent linear or nonlinear relationships.	F.3	PRI 2 PRI 3 PRI 7
<b>Lesson 3: Connecting Linear and Proportional Relationships</b>	In this lesson, students will make connections to proportional relationships studied in a previous unit by comparing proportional relationships to linear functions that are non-proportional. This will include graphing proportional and linear relationships. Students will also compare slopes and y-intercepts of two functions represented in different ways.	RP.5 F.2	PRI 1 PRI 2 PRI 5
<b>Lesson 4: Linear Functions in Context Part 1</b>	In this lesson, students will make connections to proportional relationships studied in a previous unit by comparing proportional relationships to linear functions that are non-proportional. This will include graphing proportional and linear relationships. Students will also compare slopes and y-intercepts of two functions represented in different ways.	F.4	PRI 1 PRI 2 PRI 3 PRI 4 PRI 6
<b>Lesson 5: Linear Functions in Context Part 2</b>	Students will continue writing equations from a problem situation. In lesson 5, however, students will be given 2 points or a table of values from which to write an equation of a line. Again, students will be expected to explain the meaning of the parameters in the context of the situation.	F.4	PRI 1 PRI 4 PRI 6
<b>Lesson 6: How Do Variables Vary?</b>	This lesson will give students an opportunity to analyze and describe both linear and nonlinear graphs. Special emphasis will be placed on students' understanding of the relationship between two variables. Students will interpret the relationship between variables given a graph and sketch a graph given a situation.	F.4 F.5	PRI 1 PRI 3 PRI 6
<b>Lesson 7: FAL: Interpreting Distance-Time Graphs</b>	In this formative assessment lesson, students will examine time-distance graphs and match them to interpretations of the graphs and to a table of values.	F.4 F.5	PRI 1 PRI 2 PRI 3 PRI 4 PRI 5 PRI 6 PRI 7 PRI 8 PRI 9 PRI 10

Lesson Big Idea	Lesson Details	Content Standards	Process Readiness Indicators
<b>Lesson 8: A Model for Linear Data</b>	In this lesson, students will collect real-world data and construct a scatter plot to find a line of best fit. Students will derive an equation to model the data and use the equation in order to make predictions.	SP.13 SP.14 SP.15	PRI 1 PRI 4 PRI 6 PRI 9
<b>Lesson 9: Finding a Model for U.S. Population</b>	Students will conclude this unit by revisiting the population problem presented in lesson 1. Students will examine the population data that appears to be linear over a short time period but when examined over a longer time period is not linear.	SP.13 SP.14 SP.15	PRI 1 PRI 3 PRI 4 PRI 10

Review Copy  
Not for Distribution

## Functions and Linear Relationships

# Lesson 1 of 9

### What makes a relation a function?

#### College- and Career-Readiness Standards Addressed:

- F.1 Understand that a function is a rule that assigns to each input exactly one output. The graph of a function is the set of ordered pairs consisting of an input and the corresponding output.

#### Process Readiness Indicators:

- PRI 3: Describe and justify mathematical understandings by constructing viable arguments, critiquing the reasoning of others and engaging in meaningful mathematical discourse.
- PRI 7: Look for and make use of patterns and structure.

Sequence of Instruction

Activities Checklist

#### Engage

##### PRI 3

This unit hook will give the teacher an opportunity to find out what students might remember from their previous studies of linear functions. The goal of this hook is not to plot points on a graph or write an equation of a line, but rather to facilitate mathematical communication and to assess the students' understanding about mathematical relationships.

Present students with the U.S. population clock <http://www.census.gov/popclock/>. Minimize computer screen so that students can only see the clock and not the rate of population growth displayed below the clock. (See screenshot as example below.)



Ask students to consider the following questions:

- *What do you notice?*
- *What do you wonder?*

**Think-Pair-Share:** Allow students about 2-4 minutes to study the population clock individually and jot down their thoughts about the questions asked. Then, ask students to turn to an elbow partner to share ideas. During this time, the teacher will rotate around the room listening carefully to conversations and asking probing questions when appropriate. Record the vocabulary discussed on chart paper for students to see and refer to throughout the unit.

Possible vocabulary students might discuss:

- Rate
- Constant rate of change
- Linear equation
- Straight line
- Slope or unit rate
- Function or linear function

For students who are using little to no mathematical vocabulary, consider asking questions such as:

- What do you notice about the population as time passes?
- What mathematical vocabulary can you recall that might be used to describe the population clock?
- What pattern(s) do you notice?

After students have had sufficient time to discuss their ideas with a partner, engage students in a whole-group discussion to summarize what they notice and the questions they have about the clock. Encourage students to explain their reasoning and critique the reasoning of others. Focus the conversation on the vocabulary and patterns discussed in pairs allowing students to communicate their own thinking as much as possible. (Although the goal is not to find a model for the population, it is possible that some students might attempt to write an equation or plot points on a coordinate grid. In this case, simply take note of their work to revisit in the culminating lesson.)

As an introduction to the unit, share this information with students:

*In this unit, we are going to continue our study of relationships between variables. In the U.S. population clock, our variables were time and U.S. population. We were observing how the U.S. population changes over time. In a previous unit, you examined variables in proportional relationships. We will begin this unit with an in depth look at functions and will have a chance to further examine the population clock at the end of the unit.*

## Explore

**PRI 3**  
**PRI 7**

Pose the following question in a whole-group setting:

*What is a mathematical relation?*

After giving students an opportunity to share their ideas, arrive at an agreed upon definition of relation. (For example: a set of ordered pairs). Relate this back to the relationship between time and U.S. population where the input is time and the output is population.

For this activity, each pair of students should be given a set of 12 “Relation Cards” that are labeled “function” or “not a function”. Note: The blackline master of the “Relations Cards” can be found in the Teacher’s Manual at the end of this lesson. Students should compare and contrast the relations to try to arrive at a definition of *function*. Partners should take turns justifying their reasoning to one another. For instance, when examining the two relations represented in tables, students may notice a pattern where the function has one unique output for each input, whereas the non-function has two different outputs for the same input. Students should record their ideas in the student notebook. While students are working in pairs, circulate the room listening carefully to students’ conversations and be prepared to pose good questions when needed. Make note of any misconceptions students may have and be prepared to discuss those misconceptions in the whole-group discussion.

For students who are having difficulty getting started, suggest that they begin by comparing relations represented in the same way (tables to tables, graph to graph, etc.). Some students may need to compare and contrast only tables before moving to multiple representations of relations.

Possible questions:

- What are the similarities and differences between the two sets of cards?
- How did you reach that conclusion?
- What do you notice about the output values assigned to the input values in the non-function cards compared to those in the function cards?
- What do you notice about the structure of the equation that is a function compared to the equation that is not a function?
- What patterns, if any, do you notice?

**Note to teacher:** The six “function” cards and six “not a function” cards should be copied for each pair of students. It may help students visually differentiate between the two categories by copying the “function” and “not a function” cards on different colored paper or cardstock.

## Explanation

**PRI 3**

Engage students in a whole-group discussion aimed at summarizing the relation cards activity, clearing up any student misconceptions, and developing an agreed upon definition of *function*. Students will likely have trouble with the equations in the activity. Because of the abstractness of equations, it can be more difficult to determine whether an equation represents a function or not. Make sure students understand that for  $y^2 = x$ , the input  $x = 25$  has two different outputs,  $y = -5$  and  $y = 5$ , and is therefore not a function. Allow pairs of students to communicate their reasoning and possible



definitions. Once the class has agreed on a suitable definition, allow students to complete Task #1: Frayer Map for the definition of function.

INCLUDED IN THE STUDENT MANUAL

### Task #1: Frayer Map

Definitions		Characteristics	
Examples		<b>Function</b>	
		Non-Examples	

### Practice in Small Groups

In small groups, allow students to complete Task #2: The Customers task. As you circulate around the room, listen carefully for misconceptions students may have. In particular, listen to make sure that students are interpreting the problem correctly. For instance, when  $P$  is a function of  $C$ ,  $P$  is the output and  $C$  is the input. They should be checking to see if any customers have two different phone numbers. If a customer has two different phone numbers, then  $P$  is not a function of  $C$ . Students will likely confuse  $P(C)$  and  $C(P)$ . Make sure students can identify the input and the output in each of these functions in order to distinguish between the two functions.

INCLUDED IN THE STUDENT MANUAL

### Task #2: The Customers

A certain business keeps a database of information about its customers. In the table below,  $C$  represents the customer name and  $P$  represents the home phone numbers of the customers.

- a. Let  $P$  be the rule which assigns to each phone number in the table above, the customer name(s) associated with it. Is  $P$  a function of  $C$ ? Explain your reasoning.

$C$ , Customer Name	$P$ , Home Phone Number
Heather Baker	(310) 510-0091
Mike London	(310) 520-0256
Sue Green	(323) 413-2598
Bruce Swift	(323) 413-2598
Michelle Metz	(213) 806-1124

- b. Let  $C$  be the rule that assigns to each customer shown in the table her or his home phone number. Is  $C$  a function of  $P$ ? Explain your reasoning.
- c. Explain why a business would want to use a person's social security number as way to identify a particular customer instead of their phone number.

**TEACHER ANSWER KEY:** Task #2: The Customers

A certain business keeps a database of information about its customers. In the table below,  $C$  represents the customer name and  $P$  represents the home phone numbers of the customers.

- a. Let  $P$  be the rule which assigns to each phone number in the table above, the customer name(s) associated with it. Is  $P$  a function of  $C$ ? Explain your reasoning.

$C$ , Customer Name	$P$ , Home Phone Number
Heather Baker	(310) 510-0091
Mike London	(310) 520-0256
Sue Green	(323) 413-2598
Bruce Swift	(323) 413-2598
Michelle Metz	(213) 806-1124

*$P$  is a function because it assigns to each customer exactly one home phone number.*

- b. Let  $C$  be the rule that assigns to each customer shown in the table her or his home phone number. Is  $C$  a function of  $P$ ? Explain your reasoning.

*$C$  is not a function because it assigns to the home phone number, (323)413-2598, more than one customer name: Sue Green and Bruce Swift.*

- c. Explain why a business would want to use a person's social security number as way to identify a particular customer instead of their phone number.

*A company would want to use social security numbers to identify customers, because not only does each customer have exactly one social security number, but each social security number is associated with exactly one customer.*

**Evaluate Understanding**

**PRI 3**

**Note to teacher:** Before beginning this assessment, you will need to display one piece of chart paper labeled "Function" and a second labeled "Not a Function" in the classroom.

This short activity aims to assess whether students are able to distinguish between relations that are functions and those that are not and justify their reasoning. Give each student one of the "Function or Not?" cards. On the back of each card, ask students to write her/his name, whether or not the relation is or is not a function, and a brief explanation of their answer. Students will then tape their cards on the appropriate chart paper. Students are not allowed to turn over any cards—information on the back is only for teacher use. Additionally, students should work individually on the cards to better help identify who has misconceptions.

**TEACHER ANSWER KEY:** Function or Not?

A	YES	B	YES	C	NO	D	NO
E	NO	F	YES	G	NO	H	YES
I	YES	J	YES	K	YES	L	NO
M	YES	N	NO	O	YES	P	NO
Q	YES	R	NO	S	YES	T	NO
U	NO	V	YES	W	YES	X	NO

## Closing Activity

**PRI 3**  
**PRI 7**

**Gallery Walk:** In this activity, students will critique the reasoning of their peers by reviewing the Function or Not? cards again. Provide each small group with several small sticky notes and instruct them to examine both charts (*Function* and *Not a Function*). Students should be looking for card placement in which they disagree. When a group disagrees with the placement of a card they should identify their group (or individual name) on the back of a sticky note and place it on that card. (Any student that disagrees with her/his group may also individually place a sticky note on a card.) As always, encourage students to justify their reasoning during the discussion.

**Whole Group Discussion:** Conclude the lesson with a discussion of the Gallery Walk. Also make sure to reiterate the characteristics of functions identified throughout the lesson and any misconceptions that may have arisen.

## Independent Practice:

For additional practice, students may complete Task #3: Foxes and Rabbits.

INCLUDED IN THE STUDENT MANUAL

### Task #3: Foxes and Rabbits

Given below is a table that gives the populations of foxes and rabbits in a national park over a 12 month period. Note that each value of  $t$  corresponds to the beginning of the month.

$t$ , month	1	2	3	4	5	6	7	8	9	10	11	12
$R$ , number of rabbits	1000	750	567	500	567	750	1000	1250	1433	1500	1433	1250
$F$ , number of foxes	150	143	125	100	75	57	50	57	75	100	125	143

- According to the data in the table, is  $F$  a function of  $R$ ? Is  $R$  a function of  $F$ ? Explain.
- Are either  $R$  or  $F$  functions of  $t$ ? Explain?

### TEACHER ANSWER KEY: Task #3: Foxes and Rabbits

- The key is understanding that a function is a rule that assigns to each input exactly one output, so we will test the relationships in question according to this criterion:  
*For the first part, that is, for  $F$  to be a function of  $R$ , we think of  $R$  as the input variable and  $F$  as the output variable, and ask ourselves the following question: Is there a rule, satisfying the definition of a function, which inputs a given rabbit population and outputs the corresponding fox population. The answer is no: We can see from the data that when  $R=1000$ , we have one instance where  $F=150$ , and another where  $F=50$ . Since this means that a single input value corresponds to more than one output value,  $F$  is not a function of  $R$ . In the language of the problem's context, this says that the fox population is not completely determined by the rabbit population; during two different months there are the same number of rabbits but different numbers of foxes.*



**Blackline Master – Relation Cards**

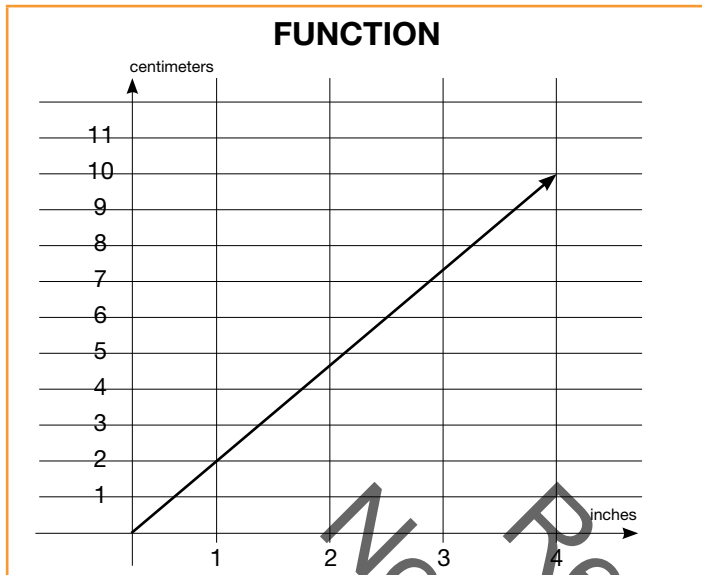

**FUNCTION**

Time (s)	Distance (m)
0	0.6
1	0.9
4	1.8
6	2.4

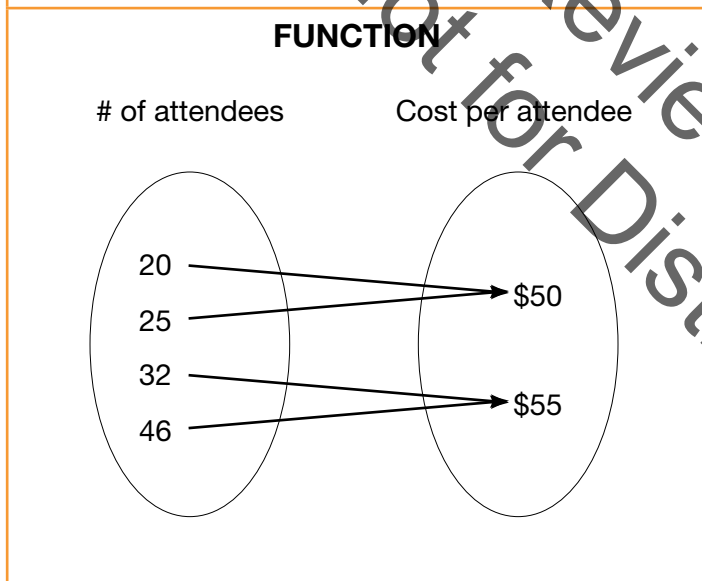

**FUNCTION**

(state, capital)

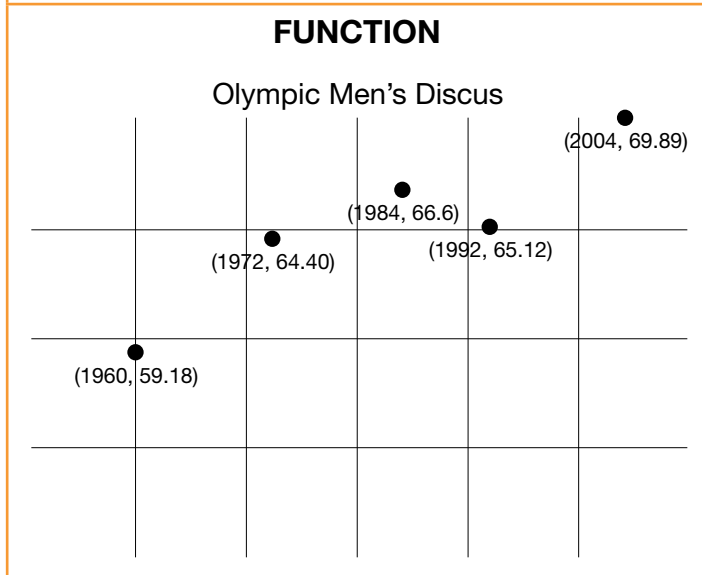

**FUNCTION**

$$y = x^2$$

**Blackline Master – Relation Cards**

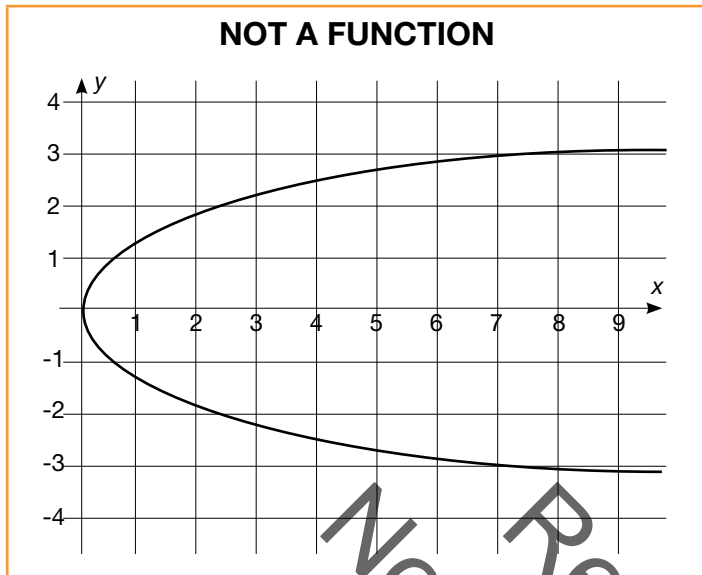

**NOT A FUNCTION**

Cost (\$)	# of items
12	1
7	2
12	4
20	5

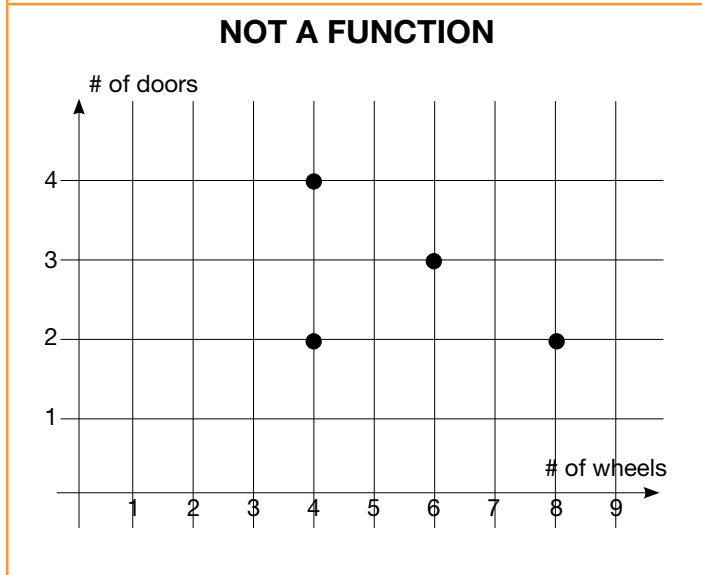
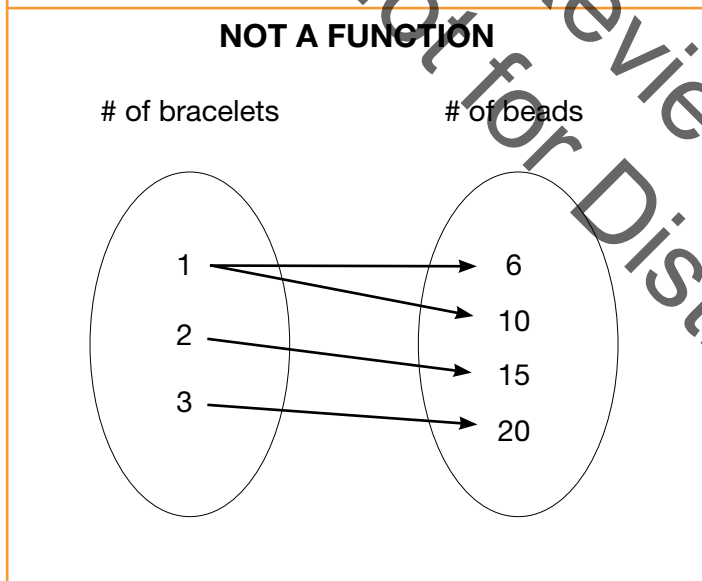

**NOT A FUNCTION**

$$y^2 = x$$

**Blackline Master – Function or Not? Cards**

<p>A</p> $y = 3x - 4$	<p>B</p> $y = \frac{1}{x}$	<p>C</p> $y^2 - 4 = x$	<p>D</p> $y = x$																																								
<p>E</p> $x = 4$	<p>F</p> $y = -7$	<p>G</p> <table border="1" data-bbox="829 785 1138 1083"> <thead> <tr> <th>x</th> <th>y</th> </tr> </thead> <tbody> <tr> <td>25</td> <td>6</td> </tr> <tr> <td>25</td> <td>9</td> </tr> <tr> <td>25</td> <td>10</td> </tr> <tr> <td>25</td> <td>25</td> </tr> </tbody> </table>	x	y	25	6	25	9	25	10	25	25	<p>H</p> <table border="1" data-bbox="1175 785 1484 1083"> <thead> <tr> <th># of days</th> <th>Cost (\$)</th> </tr> </thead> <tbody> <tr> <td>0</td> <td>0</td> </tr> <tr> <td>1</td> <td>15</td> </tr> <tr> <td>4</td> <td>75</td> </tr> <tr> <td>10</td> <td>150</td> </tr> </tbody> </table>	# of days	Cost (\$)	0	0	1	15	4	75	10	150																				
x	y																																										
25	6																																										
25	9																																										
25	10																																										
25	25																																										
# of days	Cost (\$)																																										
0	0																																										
1	15																																										
4	75																																										
10	150																																										
<p>I</p> <table border="1" data-bbox="136 1215 444 1514"> <thead> <tr> <th>Time (mins)</th> <th>Distance (m)</th> </tr> </thead> <tbody> <tr> <td>5</td> <td>375</td> </tr> <tr> <td>8</td> <td>520</td> </tr> <tr> <td>10</td> <td>720</td> </tr> <tr> <td>20</td> <td>1,420</td> </tr> </tbody> </table>	Time (mins)	Distance (m)	5	375	8	520	10	720	20	1,420	<p>J</p> <table border="1" data-bbox="483 1215 792 1514"> <thead> <tr> <th>x</th> <th>y</th> </tr> </thead> <tbody> <tr> <td>-3</td> <td>4.2</td> </tr> <tr> <td>-2</td> <td>4.2</td> </tr> <tr> <td>-1</td> <td>4.2</td> </tr> <tr> <td>0</td> <td>4.2</td> </tr> </tbody> </table>	x	y	-3	4.2	-2	4.2	-1	4.2	0	4.2	<p>K</p> <table border="1" data-bbox="829 1215 1138 1514"> <thead> <tr> <th>x</th> <th>y</th> </tr> </thead> <tbody> <tr> <td>5</td> <td>130</td> </tr> <tr> <td>7</td> <td>75</td> </tr> <tr> <td>3</td> <td>190</td> </tr> <tr> <td>5</td> <td>130</td> </tr> </tbody> </table>	x	y	5	130	7	75	3	190	5	130	<p>L</p> <table border="1" data-bbox="1175 1215 1484 1514"> <thead> <tr> <th># of workers</th> <th>Time (mins)</th> </tr> </thead> <tbody> <tr> <td>2</td> <td>60</td> </tr> <tr> <td>4</td> <td>30</td> </tr> <tr> <td>4</td> <td>25</td> </tr> <tr> <td>6</td> <td>10</td> </tr> </tbody> </table>	# of workers	Time (mins)	2	60	4	30	4	25	6	10
Time (mins)	Distance (m)																																										
5	375																																										
8	520																																										
10	720																																										
20	1,420																																										
x	y																																										
-3	4.2																																										
-2	4.2																																										
-1	4.2																																										
0	4.2																																										
x	y																																										
5	130																																										
7	75																																										
3	190																																										
5	130																																										
# of workers	Time (mins)																																										
2	60																																										
4	30																																										
4	25																																										
6	10																																										
<p>M</p> <p>(person, social security number)</p>	<p>N</p> <p>(person, car)</p>	<p>O</p> <p>(bus, bus driver)</p>	<p>P</p> <p>(child, parent)</p>																																								

**Blackline Master – Function or Not? Cards**

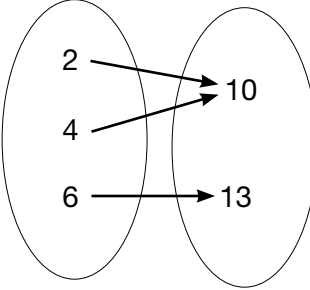
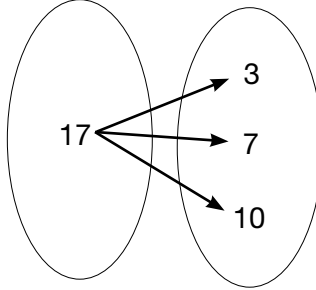
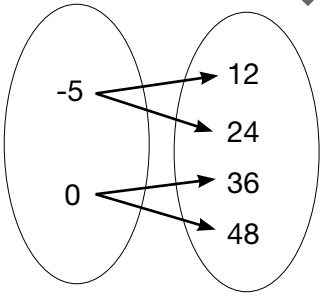
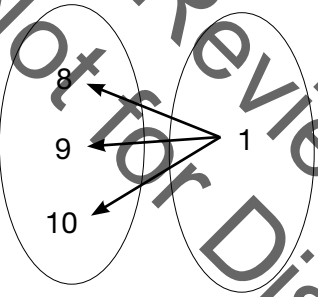
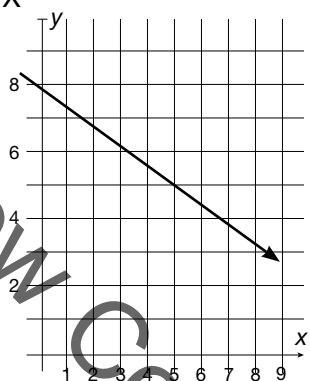
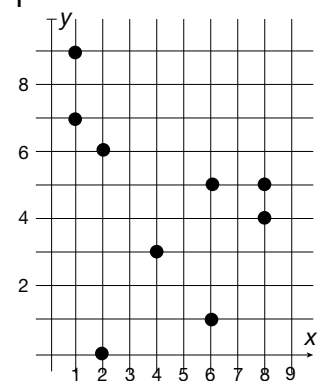
<p>Q</p> <p>(book title, ISBN)</p>	<p>R</p> <p>(zoo, pandas)</p>	<p>S</p> <p>Input      Output</p> 	<p>T</p> <p>Input      Output</p> 
<p>U</p> <p>Input      Output</p> 	<p>V</p> <p>Input      Output</p> 	<p>X</p> 	<p>Y</p> 

Not for Review Copy Distribution



## Functions and Linear Relationships

# Lesson 2 of 9

## Linear and Nonlinear Functions

### College- and Career-Readiness Standards Addressed:

Define, evaluate, and compare functions.

- F.3 Interpret the equation  $y = mx + b$  as defining a linear function, whose graph is a straight line; give examples of functions that are not linear. For example, the function  $a = s^2$  giving the area of a square as a function of its side length is not linear because its graph contains the points (1, 1), (2, 4) and (3, 9), which are not on a straight line.

### Process Readiness Indicators:

- PRI 2: Reason abstractly and quantitatively by using multiple forms of representations to make sense of and understand mathematics.
- PRI 3: Describe and justify mathematical understandings by constructing viable arguments, critiquing the reasoning of others and engaging in meaningful mathematical discourse.
- PRI 7: Look for and make use of patterns and structure.

Sequence of  
Instruction

Activities Checklist

### Engage

PRI 2  
PRI 7

Discuss the following with students in order to make a connection between this lesson and the previous.

*In the previous lesson, we examined relations in various forms to determine which ones are functions and which ones are not. We learned that functions are characterized by the relationship between their input and output values. In this lesson, we will examine various forms of functions to determine whether the functions are linear or nonlinear. Just as functions have special traits that make them functions, linear functions have special characteristics that make them linear. Do you know the characteristics of linear functions?*

Ask students to complete the table below for the function:  $y = 2x + 1$

x	$2x + 1$	y
-1		
0		
1		
2		
3		

**Solution:**

$x$	$2x + 1$	$y$
-1	$2(-1)+1$	-1
0	$2(0)+1$	1
1	$2(1)+1$	3
2	$2(2)+1$	5
3	$2(3)+1$	7

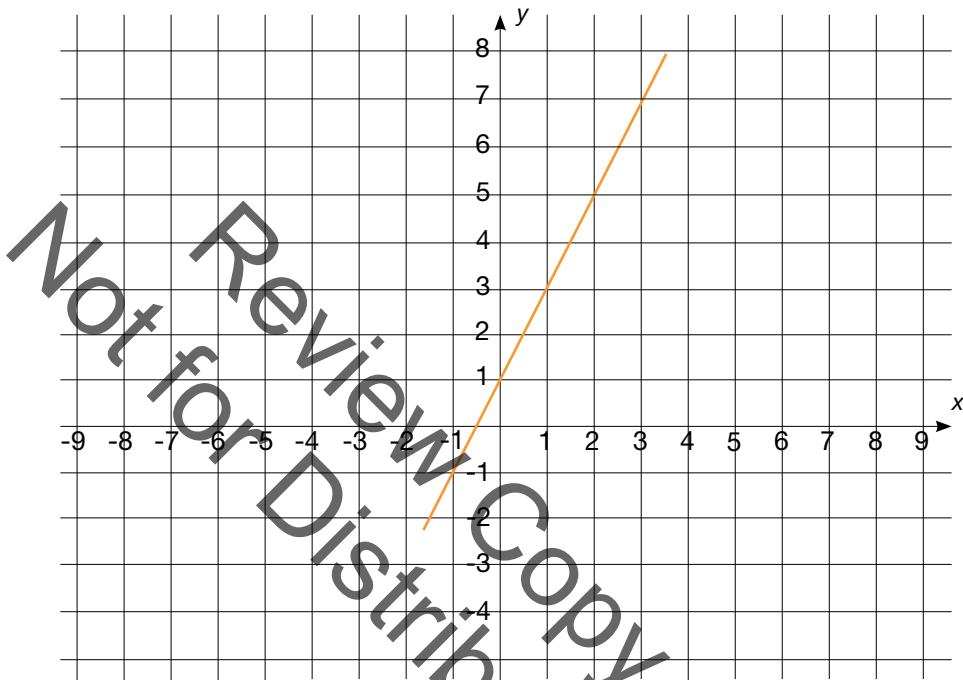

**Whole Group Discussion:** After students have completed the table, display the graph above and ask the following questions to engage students in a discussion about linear functions:

- Is the function a linear or nonlinear function?
- How can you tell that the function is linear?
- What characteristics of a linear function can you see in the table? In the equation? In the graph?

During the discussion, listen carefully to vocabulary used. Students should notice a pattern in the output values increasing by two as the input values increase by one. Make sure connections are made to constant rate of change and slope as ways of describing characteristics of the function. If no student mentions the y-intercept, ask the following questions:

- What does the “1” represent in the equation?
- Where can you see the y-intercept in the graph? In the table?
- Are there any other intercepts? Where can you see them?

By the end of the lesson, students should be able to summarize the characteristics of linear functions that will be reinforced throughout this lesson.

Explore

PRI 2  
 PRI 3

Ask students to work in pairs to complete Task #4: Identifying Linear Functions. Students should be completing all six graphs—working independently on each graph and then comparing work with their partners. While circulating the room, make sure students are not just stating “linear” or “nonlinear”, but are also giving evidence of why a function is or is not linear using appropriate vocabulary. For each nonlinear graph, students should be recognizing that a curve represents a rate of change that is not constant.

INCLUDED IN THE STUDENT MANUAL

**Task #4: Identifying Linear Functions**

Complete the table using the given input values and then plot the points on the graph. State whether the function is linear or nonlinear and justify your reasoning.

1.  $y = x - 3$

$x$	$x - 3$	$y$
-1	$(-1) - 3$	-4
0		
1		
2		

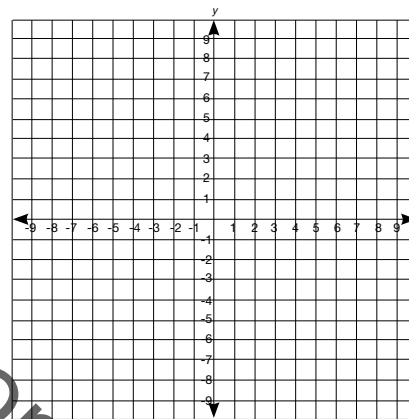

Give evidence as to whether or not this is a linear function.

2.  $y = x^2 - 3$

$x$	$x^2 - 3$	$y$
-2		
-1		
0		
1		
2		

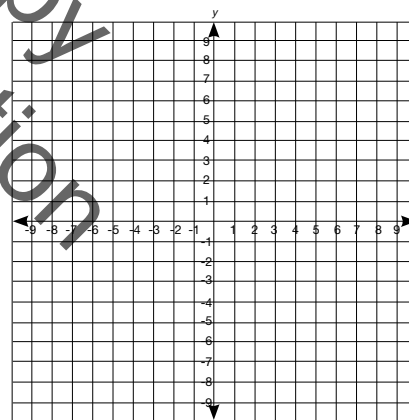

Give evidence as to whether or not this is a linear function.

3.  $y = -2x$

$x$	$-2x$	$y$
-2		
-1		
0		
1		
2		

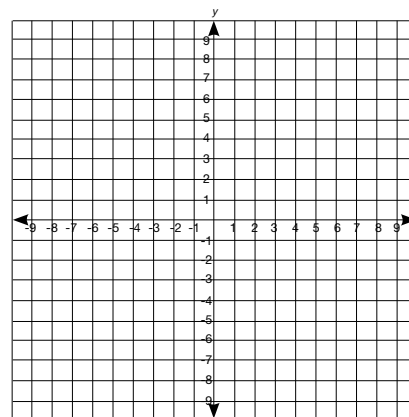

Give evidence as to whether or not this is a linear function.

4.  $y = \frac{1}{2}x$

$x$	$\frac{1}{2}x$	$y$
-4		
-2		
0		
2		
4		

Give evidence as to whether or not this is a linear function.

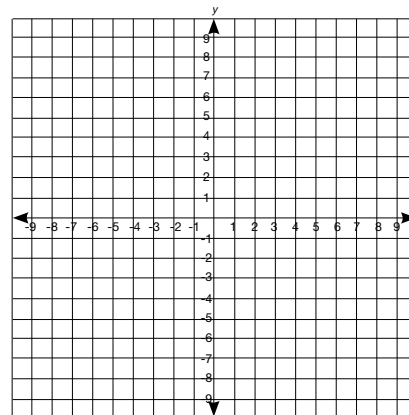

5.  $y = 2^x$

$x$	$2^x$	$y$
-1		
0		
1		
2		
3		

Give evidence as to whether or not this is a linear function.

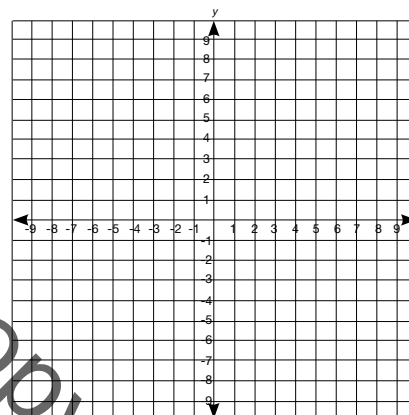

6.  $y = \frac{3}{2}x + 1$

$x$	$\frac{3}{2}x + 1$	$y$
0		
2		
4		
6		

Give evidence as to whether or not this is a linear function.

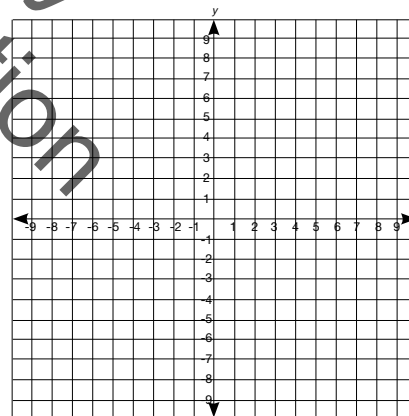

Identify pairs of students to present some (maybe not all) of the problems. One possibility would be to select three pairs of students and ask each to present their work on one of the first three problems. These would be nice problems to discuss because one of them is nonlinear and of the other two, one has a negative slope and the other has a positive slope providing a nice variety to sum up the activity. It may be that students have trouble on a particular problem and in that case, that problem would be best to highlight in the following discussion. Provide the student presenting with chart paper (preferably grid chart paper) and markers.

## Explanation

**PRI 2**  
**PRI 3**

**Student presentations:** Ask pairs of students presenting to explain their work and most importantly, why their function is or is not linear. After students have presented, engage the class in a discussion about the problems to ensure that they can differentiate linear from nonlinear functions in all representations. They should be able to identify a rate of change that is not constant on a graph and on a table as well as identify elements of equations that make them nonlinear.

### TEACHER ANSWER KEY Task #4: Identifying Linear Functions

Complete the table using the given input values and then plot the points on the graph. State whether the function is linear or nonlinear and justify your reasoning.

1.  $y = x - 3$

$x$	$x - 3$	$y$
-1	$(-1) - 3$	-4
0	$(0) - 3$	-3
1	$(1) - 3$	-2
2	$(2) - 3$	-1

Give evidence as to whether or not this is a linear function.

*The function has a constant rate of change.*

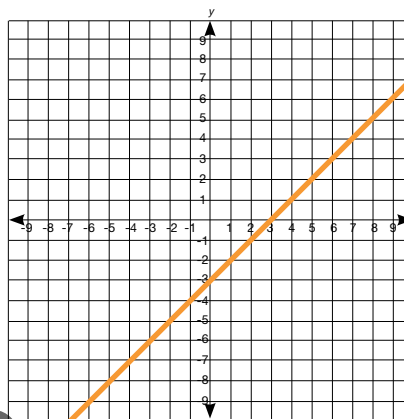

2.  $y = x^2 - 3$

$x$	$x^2 - 3$	$y$
-2	$(-2)^2 - 3$	1
-1	$(-1)^2 - 3$	-2
0	$(0)^2 - 3$	-3
1	$(1)^2 - 3$	-2
2	$(2)^2 - 3$	1

Give evidence as to whether or not this is a linear function.

*The function does not have a constant rate of change.*

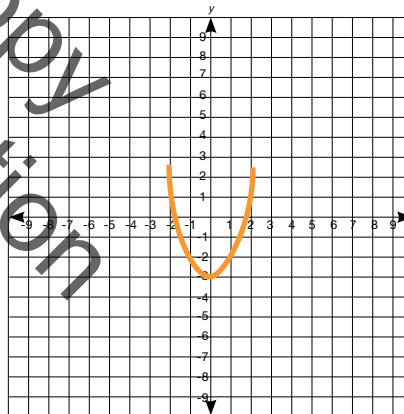

3.  $y = -2x$

$x$	$-2x$	$y$
-2	$-2(-2)$	4
-1	$-2(-1)$	2
0	$-2(0)$	0
1	$-2(1)$	-2
2	$-2(2)$	-4

Give evidence as to whether or not this is a linear function.

*The function has a constant rate of change.*

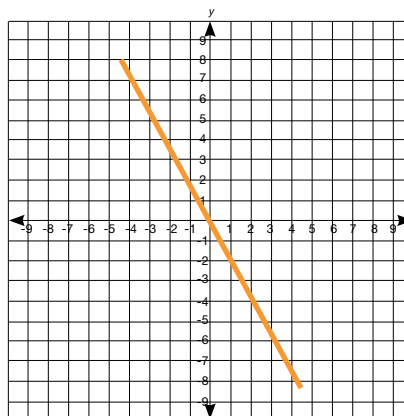

4.  $y = \frac{1}{2}x$

$x$	$\frac{1}{2}x$	$y$
-4	$\frac{1}{2}(-4)$	-2
-2	$\frac{1}{2}(-2)$	-1
0	$\frac{1}{2}(0)$	0
2	$\frac{1}{2}(2)$	1
4	$\frac{1}{2}(4)$	2

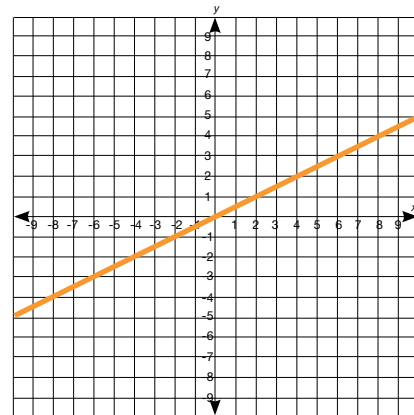

Give evidence as to whether or not this is a linear function.

*The function has a constant rate of change.*

5.  $y = 2^x$

$x$	$2^x$	$y$
-1	$2^{-1}$	$\frac{1}{2}$
0	$2^0$	1
1	$2^1$	2
2	$2^2$	4
3	$2^3$	8

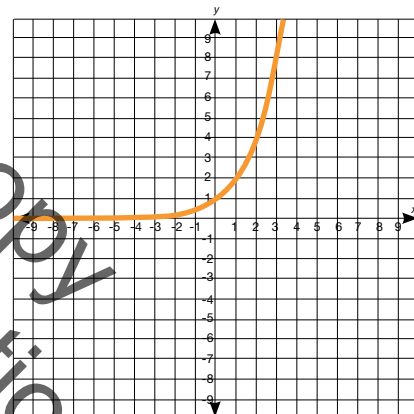

Give evidence as to whether or not this is a linear function.

*The function does not have a constant rate of change.*

6.  $y = \frac{3}{2}x + 1$

$x$	$\frac{3}{2}x + 1$	$y$
0	$\frac{3}{2}(0) + 1$	1
2	$\frac{3}{2}(2) + 1$	4
4	$\frac{3}{2}(4) + 1$	7
6	$\frac{3}{2}(6) + 1$	10

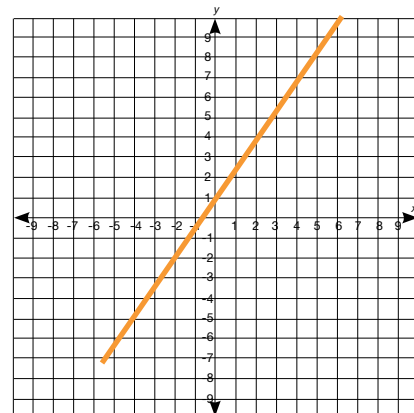

Give evidence as to whether or not this is a linear function.

*The function has a constant rate of change.*

## Practice Independently

**PRI 2**  
**PRI 7**

Ask students to work independently on Task #5: Identifying Linear Functions Practice. There are likely more problems here than time will allow for during class. Consider assigning only half of each part and then assign the remaining problems for homework. Encourage students to look for patterns and make connections between the different representations of linear functions.

INCLUDED IN THE STUDENT MANUAL

### Task #5: Identifying Linear Functions Practice

**Part 1:** Without graphing, determine whether or not each of the tables represents a linear function and then justify your reasoning.

a)

x	y
3	3
4	5
5	7
6	9

Is this a linear function?  Yes  No  
How do you know?

---



---



---

b)

x	y
-1	1
0	0
1	1
2	4

Is this a linear function?  Yes  No  
How do you know?

c)

x	y
-3	5
-2	1
-1	-3
0	-7

Is this a linear function?  Yes  No  
How do you know?

---



---



---

d)

x	y
0	5
1	5
2	5
3	5

Is this a linear function?  Yes  No  
How do you know?

---



---



---

e)

x	y
-4	4
-4	8
-4	13
-4	19

Is this a linear function?  Yes  No

How do you know?

---



---



---

f)

x	y
1	-3
2	-7
3	-10
4	-13

Is this a linear function?  Yes  No

How do you know?

---



---



---

**Part 2:** For each equation, determine if the function is linear. If so, then find the slope and y-intercept. If not, explain how you know.

a)  $y = 3x + 5$

Is this function linear?  Yes  No

If the function is linear...

What is the slope? \_\_\_\_\_

What is the y-intercept? \_\_\_\_\_

If it is not a linear function, how do you know?

---



---



---

b)  $y = 2x^2 + 1$

Is this function linear?  Yes  No

If the function is linear...

What is the slope? \_\_\_\_\_

What is the y-intercept? \_\_\_\_\_

If it is not a linear function, how do you know?

---



---



---

c)  $y = 5 - \frac{4}{5}x$

Is this function linear?  Yes  No

If the function is linear...

What is the slope? \_\_\_\_\_

What is the y-intercept? \_\_\_\_\_

If it is not a linear function, how do you know?

---



---



---

d)  $y = \frac{5}{x} + 2$

Is this function linear?  Yes  No

If the function is linear...

What is the slope? \_\_\_\_\_

What is the y-intercept? \_\_\_\_\_

If it is not a linear function, how do you know?

---



---



---



e)  $x = 10$

Is this function linear?  Yes  No

If the function is linear...

What is the slope? \_\_\_\_\_

What is the y-intercept? \_\_\_\_\_

If it is not a linear function, how do you know?  
 \_\_\_\_\_  
 \_\_\_\_\_

f)  $y = 3$

Is this function linear?  Yes  No

If the function is linear...

What is the slope? \_\_\_\_\_

What is the y-intercept? \_\_\_\_\_

If it is not a linear function, how do you know?  
 \_\_\_\_\_  
 \_\_\_\_\_

**Part 3:** For each graph, determine whether or not it represents a linear function. Then, explain your reasoning.

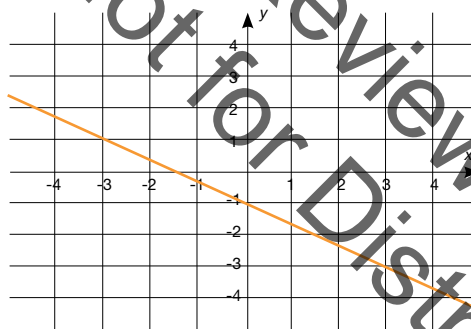

Is this function linear?  Yes  No

Explain your reasoning.  
 \_\_\_\_\_  
 \_\_\_\_\_

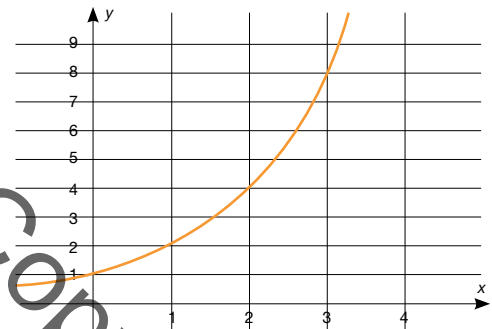

Is this function linear?  Yes  No

Explain your reasoning.  
 \_\_\_\_\_  
 \_\_\_\_\_

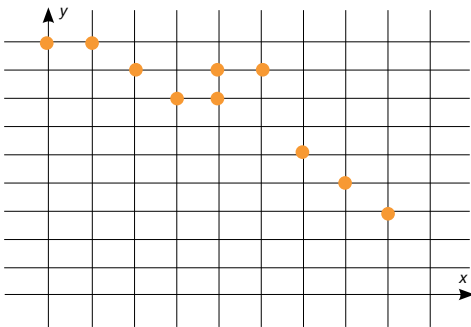

Is this function linear?  Yes  No

Explain your reasoning.  
 \_\_\_\_\_  
 \_\_\_\_\_

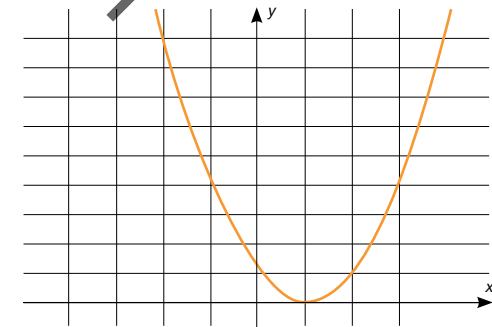

Is this function linear?  Yes  No

Explain your reasoning.  
 \_\_\_\_\_  
 \_\_\_\_\_

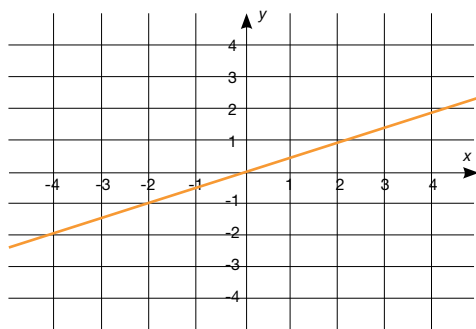

Is this function linear?  Yes  No  
Explain your reasoning.

---



---



---

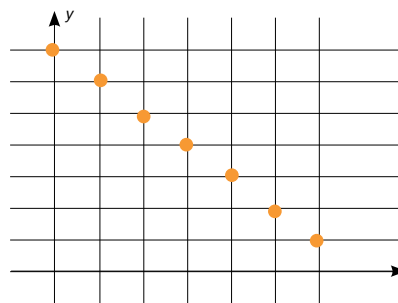

Is this function linear?  Yes  No  
Explain your reasoning.

---



---



---

**TEACHER ANSWER KEY** Task #5: Identifying Linear Functions Practice

**Part 1:** Without graphing, determine whether or not each of the tables represents a linear function and then justify your reasoning.

a)

x	y
3	3
4	5
5	7
6	9

Is this a linear function? Yes  
*The function has a constant rate of change.*

c)

x	y
-3	5
-2	1
-1	-3
0	-7

Is this a linear function? Yes  
*The function has a constant rate of change.*

b)

x	y
-1	1
0	0
1	1
2	4

Is this a linear function? No  
*The function does not have a constant rate of change.*

d)

x	y
0	5
1	5
2	5
3	5

Is this a linear function? Yes  
*The function has a constant rate of change.*

e)

x	y
-4	4
-4	8
-4	13
-4	19

Is this a linear function? *No*

*These values do not represent a function because there is more than one output to a single input.*

f)

x	y
1	-3
2	-7
3	-10
4	-13

Is this a linear function? *No*

*The function does not have a constant rate of change.*

**Part 2:** For each equation, determine if the function is linear. If so, then find the slope and y-intercept. If not, explain how you know.

a)  $y = 3x + 5$

Is this function linear? *Yes*

If the function is linear...

What is the slope? *3*

What is the y-intercept? *5*

If it is not a linear function, how do you know?

b)  $y = 2x^2 + 1$

Is this function linear? *No*

If the function is linear...

What is the slope? *NA*

What is the y-intercept? *NA*

If it is not a linear function, how do you know?

*The x value is squared which means the rate of change will not be constant.*

c)  $y = 5 - \frac{4}{5}x$

Is this function linear? *Yes*

If the function is linear...

What is the slope?  *$-\frac{4}{5}$*

What is the y-intercept? *5*

If it is not a linear function, how do you know?

d)  $y = \frac{5}{x} + 2$

Is this function linear? *No*

If the function is linear...

What is the slope? *NA*

What is the y-intercept? *NA*

If it is not a linear function, how do you know?

*The x value is in the denominator so there will not be a constant rate of change.*

e)  $x = 10$

Is this function linear? *No*

If the function is linear...

What is the slope? *NA*

What is the y-intercept? *NA*

If it is not a linear function, how do you know?

*This equation does not represent a function because there are multiple outputs to a single input.*

f)  $y = 3$

Is this function linear? *Yes*

If the function is linear...

What is the slope? *0*

What is the y-intercept? *3*

If it is not a linear function, how do you know?

**Part 3:** For each graph, determine whether or not it represents a linear function. Then, explain your reasoning.

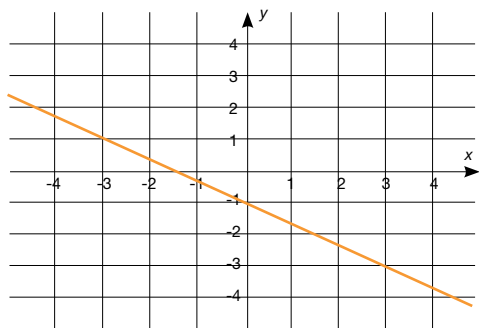

Is this function linear? *Yes*

*This function has a constant rate of change.*

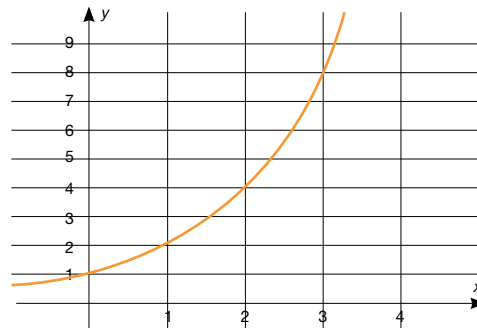

Is this function linear? *No*

*This function does not have a constant rate of change.*

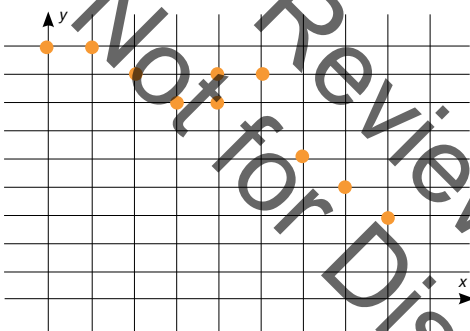

Is this function linear? *No*

*This graph does not represent a function because two outputs are mapped to the same input.*

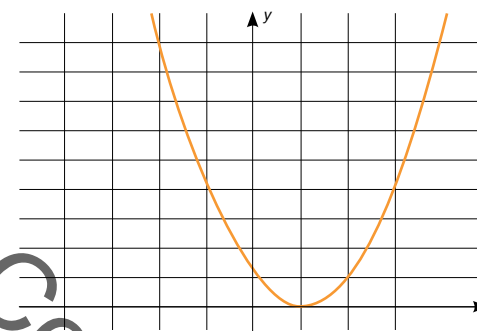

Is this function linear? *No*

*This function does not have a constant rate of change.*

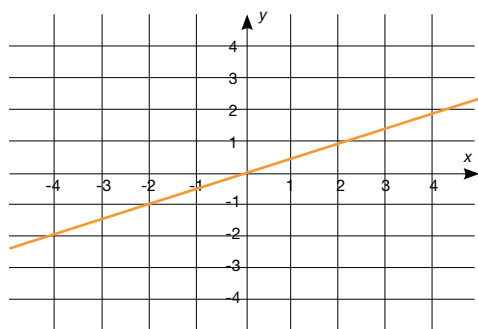

Is this function linear? *Yes*

*This function has a constant rate of change.*

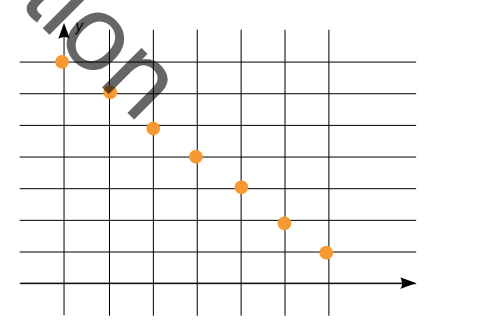

Is this function linear? *Yes*

*This function has a constant rate of change.*

## Evaluate Understanding

While students are working independently on Task #5: Identifying Linear Functions Practice, pay close attention to their work. Try to identify students who are struggling to clear up any issues before leaving class. If many students are having difficulty with the same representation (equations, tables, graphs), then a brief whole-class discussion may be necessary.

## Closing Activity

End with an exit ticket to assess students' understanding of the lesson. Ask students to complete Task #6: Lesson 2 Exit Ticket prior to leaving class. This topic may need to be revisited in the next lesson if students show a lack of understanding.

INCLUDED IN THE STUDENT MANUAL

### Task #6: Lesson 2 Exit Ticket

- 1) Explain why the graphed function does NOT represent a linear relationship.

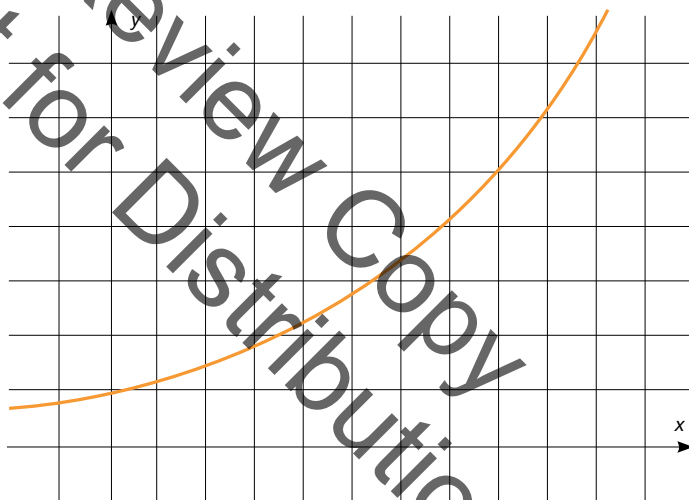

- 2) Determine whether the table of values is a linear function or not.  
Is this function linear?  Yes  No Explain your reasoning.

$x$	$y$
0	20
2	10
4	0
6	-10

**TEACHER ANSWER KEY** Task #6: Lesson 2 Exit Ticket

1) Explain why the graphed function does NOT represent a linear relationship.

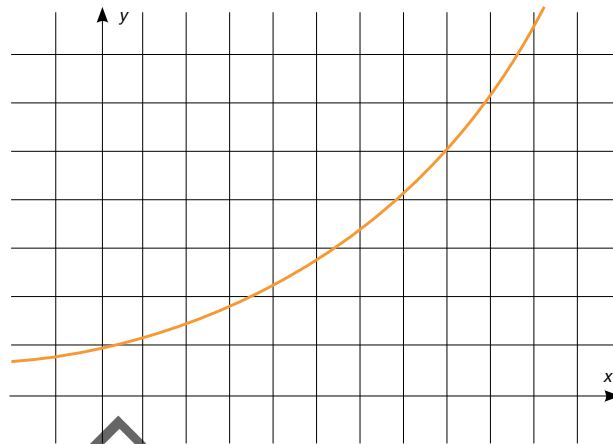

*This graph does not represent a linear function because the curve indicates that there is not a constant rate of change. In order for a function to be linear, it must have a constant slope.*

2) Determine whether the table of values is a linear function or not.  
Is this function linear? Yes

x	y
0	20
2	10
4	0
6	-10

Explain your reasoning.

*These values represent a linear relationship because for every increase of 2 for the x values, the y values decrease by 10. This indicates that there is a constant rate of change.*

**Independent Practice:**

Students should complete these problems if not completed in class. Task #5: Identifying Linear Functions Practice.

**Resources/Instructional Materials Needed:**

- Task #4: Identifying Linear Functions
- Task #5: Identifying Linear Functions Practice
- Task #6: Lesson 2 Exit Ticket
- computer with internet access and projector
- graph paper
- rulers
- Grid chart paper
- markers

## Functions and Linear Relationships

# Lesson 3 of 9

## Connecting Linear and Proportional Relationships

### College- and Career-Readiness Standards Addressed:

---

Analyze proportional relationships and use them to solve real-world and mathematical problems.

- RP.5 Recognize and represent proportional relationships between quantities.

Define, evaluate, and compare functions.

- F.2 Compare properties of two functions each represented in a different way (algebraically, graphically, numerically in tables, or by verbal descriptions). For example, given a linear function represented by a table of values and a linear function represented by an algebraic expression, determine which function has the greater rate of change.

### Process Readiness Indicators:

---

- PRI 1: Make sense of problems and persevere in solving through reasoning and exploration.
- PRI 2: Reason abstractly and quantitatively by using multiple forms of representations to make sense of and understand mathematics.
- PRI 3: Use appropriate tools strategically to support thinking and problem solving.

Sequence of  
Instruction

Activities Checklist

### Engage

---

#### PRI 1

Direct students to Task #7: Yard Work in their student manual and ask them to work on it independently. This problem should provide an opportunity to see how much students remember from their earlier study of proportional relationships. Can they make sense of the problem? Are they able to correctly fill out the table and write an equation to represent the relationship? Do they know the difference in a proportional relationship and one that is not? (Note to teacher: reference work in Unit 2 on proportional relationships).

INCLUDED IN THE STUDENT MANUAL

**Task #7: Yard Work**

Your parents are trying to get your little sister to help with the yard work. They offer her \$4.50 for every bag she fills with leaves.

number of bags, $n$	1	2	3	5	8
Amount Paid (\$), $A$					

- Complete the table.
  - What is the rate of pay?
- 
- What equation could you write to calculate your little sister's earnings?

- Is the relationship of your little sister's earnings,  $A$ , to the number of bags she fills,  $n$ , a proportional relationship? Explain how you know.
- 
- 
- 

**Whole group discussion:** Use this time to address any misconceptions that may have been uncovered as you circulate the room. Make sure to discuss the relationship between the number of bags filled and the amount paid in the table. Students should notice that in order to calculate the amount paid, the number of bags filled is multiplied by \$4.50. Therefore, the relationship between the two variables is a multiplicative one with a constant of \$4.50 making this a proportional relationship.

**TEACHER ANSWER KEY** Task #7: Yard Work

number of bags, $n$	1	2	3	5	8
Amount Paid (\$), $A$	\$4.50	\$9.00	\$13.50	\$22.50	\$36.00

- Complete the table.
- What is the rate of pay?  $\$4.50$  per bag
- What equation could you write to calculate your little sister's earnings?  $A = 4.50n$
- Is the relationship of your little sister's earnings,  $A$ , to the number of bags she fills,  $n$ , a proportional relationship? Explain how you know.

*Yes, the relationship is proportional. The amount paid is increasing at a constant rate and the amount paid for 0 bags is \$0.*



**Explore**

**PRI 1**  
**PRI 2**  
**PRI 5**

Ask students to begin working on Task #8: Music Downloads from the student manual. The students will use the information given in the problem to understand linear relationships represented in tables, verbally, and eventually developing equations to model the relationships. They should be given approximately 10 minutes to work independently on the task before being allowed to collaborate in their small groups. This time will allow them an opportunity to make sense of the problem and reason quantitatively to complete the tables before working together on the questions. If there are students struggling to make sense of the problem and complete the table, it may be beneficial to ask some probing questions or to pair them with students who are able to assist. If a large number of students are having trouble after Task #7 Yard Work, then a video prior to this task may also be helpful <https://www.youtube.com/watch?v=6AjBsO4qswv>.

INCLUDED IN THE STUDENT MANUAL

**Task #8: Music Downloads**

Nadia is comparing two online music download services. Nadia began to record the cost to download music from Company A in the first table below. She knows that Company B offers music downloads for \$0.49 per song after a \$20.00 membership fee. To help her determine the better deal, Nadia also created a table for Company B in order to compare costs.

Complete the tables below.

**Company A**

Number of Songs	Process	Cost to Download	Final Cost per Song
5	$5(.99)$	\$4.95	\$0.99
10	$10(.99)$	\$9.90	\$0.99
15			
20			
25			
30			
35			
40			

**Company B**

Number of Songs	Process	Cost to Download	Final Cost per Song
5	$20+5(.49)$	\$22.45	\$4.49
10			
15			
20			
25			
30			
35			
40			

Use the tables for Company A and Company B to answer the following questions.

1. For Company A:

a. How can you find the cost of downloading any number of songs?

---

---

b. What is the equation that relates  $y$ , the cost to download, to  $x$ , the number of songs?

---

---

c. What do you notice about the final cost per song?

---

---

d. Is the relationship proportional? How do you know?

---

---

2. For Company B:

a. How can you find the cost of downloading any number of songs?

---

---

b. What is the equation that relates  $y$ , the cost to download, to  $x$ , the number of songs?

---

---

c. What do you notice about the final cost per song?

---

---

d. Is the relationship proportional? How do you know?

---

---

Not for Review Copy  
Distribution

3. Graph both relationships on the same coordinate grid.

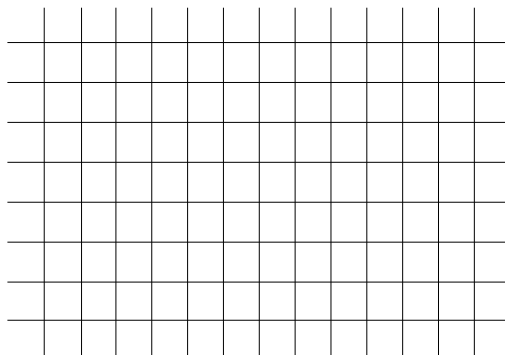

4. What similarities and differences do you notice between the equation that represents a proportional relationship and the equation that represents a non-proportional relationship?

---

---

5. What similarities and differences do you notice between the graph that represents a proportional relationship and the graph that represents a non-proportional relationship?

---

---

6. What similarities and differences do you notice between the table that represents a proportional relationship and the table that represents a non-proportional relationship?

---

---

### Explanation

PRI 1  
PRI 2  
PRI 5

**Note to teacher:** To prepare for this discussion, display the equations, graphs, and tables from #4-6 along with the chart below, each on a separate piece of chart paper (a total of 3 pieces of chart paper). As stated above, you may also choose to compare and contrast using a Double Bubble.

Similarities	Differences

**Whole group discussion:** In this discussion, students will have an opportunity to share their solutions to #4, #5, and #6 from Task #8: Music Downloads. For each representation (equation, graph, and table), record the similarities and differences that students notice. Make sure that comparisons of slope and y-intercept are being drawn across different representations. For instance, students should see that a proportional relationship has the point (0, 0) in a table, passes through the origin on a graph, and has a b value of 0 in slope-intercept form of the equation of a line. The same should be done for slope.

**TEACHER ANSWER KEY** Task #8: Music Downloads

Nadia is comparing two online music download services. Nadia began to record the cost to download music from Company A in the first table below. She knows that Company B offers music downloads for \$0.49 per song after a \$20.00 membership fee. To help her determine the better deal, Nadia also created a table for Company B in order to compare costs.

Complete the tables below.

**Company A**

Number of Songs	Process	Cost to Download	Final Cost per Song
5	$5(.99)$	\$4.95	\$0.99
10	$10(.99)$	\$9.90	\$0.99
15	$15(.99)$	\$14.85	\$0.99
20	$20(.99)$	\$19.80	\$0.99
25	$25(.99)$	\$24.75	\$0.99
30	$30(.99)$	\$29.70	\$0.99
35	$35(.99)$	\$34.65	\$0.99
40	$40(.99)$	\$39.60	\$0.99

**Company B**

Number of Songs	Process	Cost to Download	Final Cost per Song
5	$20+5(.49)$	\$22.45	\$4.49
10	$20+10(.49)$	\$24.90	\$2.49
15	$20+15(.49)$	\$27.35	\$1.82
20	$20+20(.49)$	\$29.80	\$1.49
25	$20+25(.49)$	\$32.25	\$1.29
30	$20+30(.49)$	\$34.70	\$1.16
35	$20+35(.49)$	\$37.15	\$1.06
40	$20+40(.49)$	\$39.60	\$0.99

Use the tables for Company A and Company B to answer the following questions.

1. For Company A:

a. How can you find the cost of downloading any number of songs?

*Multiply the number of songs by \$0.99.*

- b. What is the equation that relates  $y$ , the cost to download, to  $x$ , the number of songs?

$$y = 0.99x$$

- c. What do you notice about the final cost per song?

*The cost per song will always be \$0.99.*

- d. Is the relationship proportional? How do you know?

*Yes, the cost per song is constant and there is no membership fee.*

2. For Company B:

- a. How can you find the cost of downloading any number of songs?

*Multiply the number of songs by 0.49 and then add the \$20 membership fee.*

- b. What is the equation that relates  $y$ , the cost to download, to  $x$ , the number of songs?

$$y = 0.49x + 20$$

- c. What do you notice about the final cost per song?

*The cost per song is not constant and decreases as the number of songs increases.*

- d. Is the relationship proportional? How do you know?

*No, the cost per song is not constant and there is an initial value, or membership fee.*

3. Graph both relationships on the same coordinate grid.

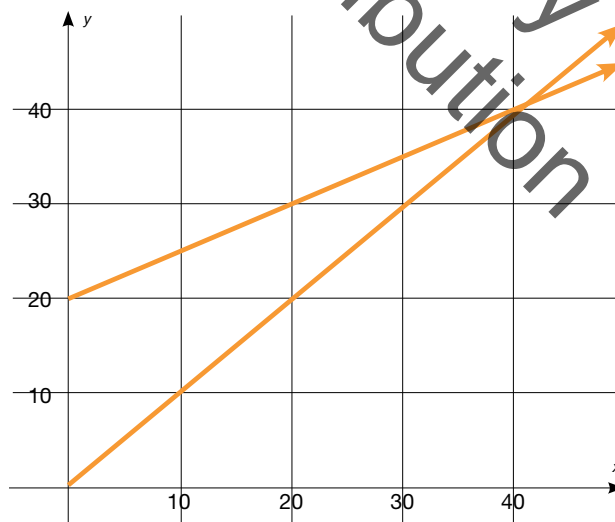

4. What similarities and differences do you notice between the equation that represents a proportional relationship and the equation that represents a non-proportional relationship?

- *Both equations are in slope-intercept form.*
- *Company A has a y-intercept of 0 and Company B has a y-intercept of 20.*
- *Company A has a slope of 0.99 and Company B has a slope of 0.49.*

5. What similarities and differences do you notice between the graph that represents a proportional relationship and the graph that represents a non-proportional relationship?
  - *Both graphs have a constant rate change.*
  - *Company A graph passes through the origin and Company B begins higher on the y-axis.*
6. What similarities and differences do you notice between the table that represents a proportional relationship and the table that represents a non-proportional relationship?
  - *In both tables, the cost to download increases as the number of songs increases.*
  - *In the Company A table, the cost per song is constant but the cost per song is not constant in the Company B table.*

### Practice in Small Groups

---

Instruct the students to complete Task #9: Comparing Functions in the student manual working in small groups. In this task, students will compare two functions represented in different ways. The task can also be accessed at <http://bit.ly/1VWYOZR>.

Not for Review Copy  
Not for Distribution

INCLUDED IN THE STUDENT MANUAL

### Task #9: Comparing Functions

# Comparing Functions

Name: \_\_\_\_\_

Date: \_\_\_\_\_ Period: \_\_\_\_\_

**8.F.2:** Compare properties of two functions each represented in a different way (algebraically, graphically, numerically in tables, or by verbal descriptions).

Read each situation, then answer the questions by analyzing and comparing the different linear situations.

1. The Metropolis Zoo recently celebrated the birth of two new baby pandas!

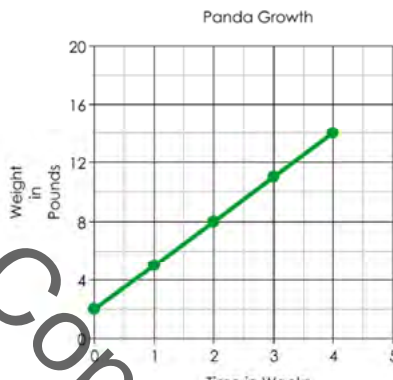
<p><b>Mochi</b> the panda cub has been measured and weighed each week since she was born.</p> <table border="1" style="margin-left: auto; margin-right: auto; border-collapse: collapse;"> <thead> <tr> <th style="padding: 5px;">Weeks</th> <th style="padding: 5px;">Weight</th> </tr> </thead> <tbody> <tr> <td style="text-align: center; padding: 5px;">0</td> <td style="text-align: center; padding: 5px;">1</td> </tr> <tr> <td style="text-align: center; padding: 5px;">1</td> <td style="text-align: center; padding: 5px;">5</td> </tr> <tr> <td style="text-align: center; padding: 5px;">2</td> <td style="text-align: center; padding: 5px;">9</td> </tr> <tr> <td style="text-align: center; padding: 5px;">3</td> <td style="text-align: center; padding: 5px;">13</td> </tr> </tbody> </table>	Weeks	Weight	0	1	1	5	2	9	3	13	<p>Mochi's brother is <b>Kappa</b>. His weight has been charted on the graph below.</p> <div style="text-align: center;">  </div>
Weeks	Weight										
0	1										
1	5										
2	9										
3	13										

- Which panda was heavier when they were born?
- Which panda is growing faster?
- Which panda will weigh more at five weeks?

2. Two contestants on Biggest Loser are Valerie and Oscar. Their weight loss progress is shown below.

<p>Valerie's weight loss is shown by this function, where <math>W</math> is her weight in pounds and <math>t</math> is the time in weeks.</p> $W = 235 - 2.5t$	<p>Oscar's weight loss is tracked in the table below.</p> <table border="1" style="margin-left: auto; margin-right: auto; border-collapse: collapse;"> <thead> <tr> <th style="padding: 5px;">Weeks</th> <th style="padding: 5px;">0</th> <th style="padding: 5px;">2</th> <th style="padding: 5px;">5</th> <th style="padding: 5px;">6</th> </tr> </thead> <tbody> <tr> <td style="padding: 5px;">Weight</td> <td style="text-align: center; padding: 5px;">247</td> <td style="text-align: center; padding: 5px;">243</td> <td style="text-align: center; padding: 5px;">237</td> <td style="text-align: center; padding: 5px;">235</td> </tr> </tbody> </table>	Weeks	0	2	5	6	Weight	247	243	237	235
Weeks	0	2	5	6							
Weight	247	243	237	235							

- Who weighed more at the beginning of the show?
- Who is losing weight faster?

3. Mr. Rich recently planted a crop of money trees in his garden.

**A.**  
 The first tree was five inches tall when planted. It has grown four inches every month since being planted.

**B.**  
 Measurements were taken of the second tree and given below:

Months	0	2	3	5
Height	3	12	16.5	25.5

**C.**



- Which of the trees is growing the fastest?
- Which tree was the tallest when it was first planted?
- Challenge: Which tree is the tallest after 6 months?

4. Tony is the best pizza deliveryman in the city. He has been offered jobs by all the best pizza places.

**Bombinoes' Pizza** is offering \$56 per shift and \$2.50 in commission for each pizza delivered.

**Little Squeezer's** showed Tony a table of salaries.

Pizzas	0	2	4	10
Salary	48	54	60	78

**Pizza Tent** has given Tony his pay options in the following function.  $S$  represents Tony's salary, and  $p$  represents the number of pizzas he delivers.

$$S = 2.75p + 52$$

**Papa Ron's** made their offer in the form of this graph.



- Which company pays the best pay per shift?
- Which company pays the most per pizza?
- Challenge: If Tony is going to deliver at least 20 pizzas every night, which company should he work for?



## Evaluate Understanding

**Whole group discussion:** Ask the students to share their responses to the questions in the Comparing Functions task. The focus here will be more on comparing the rates rather than deciding whether or not the relationship is proportional. Make sure, however, that students are able to recognize that none of the functions in this task are proportional and more importantly, that they can justify how they know.

### TEACHER ANSWER KEY Task #9: Comparing Functions

## Comparing Functions

Name: ANSWER KEY

Date: \_\_\_\_\_ Period: \_\_\_\_

**8.F.2:** Compare properties of two functions each represented in a different way (algebraically, graphically, numerically in tables, or by verbal descriptions).

Read each situation, then answer the questions by analyzing and comparing the different linear situations.

1. The Metropolis Zoo recently celebrated the birth of two new baby pandas!

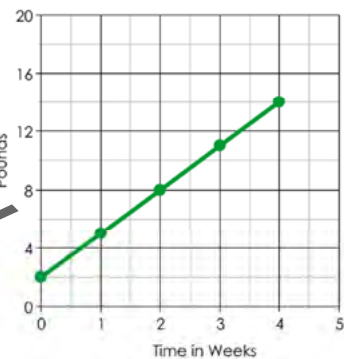
<p><b>Mochi</b> the panda cub has been measured and weighed each week since she was born.</p> <table border="1" style="margin-left: auto; margin-right: auto; border-collapse: collapse;"> <thead> <tr> <th style="padding: 5px;">Weeks</th> <th style="padding: 5px;">Weight</th> </tr> </thead> <tbody> <tr> <td style="text-align: center; padding: 5px;">0</td> <td style="text-align: center; padding: 5px;">1</td> </tr> <tr> <td style="text-align: center; padding: 5px;">1</td> <td style="text-align: center; padding: 5px;">5</td> </tr> <tr> <td style="text-align: center; padding: 5px;">2</td> <td style="text-align: center; padding: 5px;">9</td> </tr> <tr> <td style="text-align: center; padding: 5px;">3</td> <td style="text-align: center; padding: 5px;">13</td> </tr> </tbody> </table>	Weeks	Weight	0	1	1	5	2	9	3	13	<p>Mochi's brother is <b>Kappa</b>. His weight has been charted on the graph below.</p> <div style="text-align: center;">  </div>
Weeks	Weight										
0	1										
1	5										
2	9										
3	13										

- Which panda was heavier when they were born?  
*Kappa is heavier. He weighed 2 pounds at birth, while Mochi weighed only 1 pound.*
- Which panda is growing faster?  
*Mochi is growing faster. She is gaining 4 pounds per week. Kappa is gaining 6 pounds per week.*
- Which panda will weigh more at five weeks?  
*Mochi will weigh more. She will be up to 21 pounds. ( $y = 4x + 1$ ) Kappa will only be up to 17 pounds. ( $y = 3x + 2$ ).*

2. Two contestants on Biggest Loser are Valerie and Oscar. Their weight loss progress is shown below.

<p>Valerie's weight loss is shown by this function, where <math>W</math> is her weight in pounds and <math>t</math> is the time in weeks.</p> $W = 235 - 2.5t$	<p>Oscar's weight loss is tracked in the table below.</p> <table border="1" style="margin-left: auto; margin-right: auto; border-collapse: collapse;"> <thead> <tr> <th style="padding: 5px;">Weeks</th> <th style="padding: 5px;">0</th> <th style="padding: 5px;">2</th> <th style="padding: 5px;">5</th> <th style="padding: 5px;">6</th> </tr> </thead> <tbody> <tr> <td style="padding: 5px;">Weight</td> <td style="text-align: center; padding: 5px;">247</td> <td style="text-align: center; padding: 5px;">243</td> <td style="text-align: center; padding: 5px;">237</td> <td style="text-align: center; padding: 5px;">235</td> </tr> </tbody> </table>	Weeks	0	2	5	6	Weight	247	243	237	235
Weeks	0	2	5	6							
Weight	247	243	237	235							

- Who weighed more at the beginning of the show?  
*Oscar weighed more. He weighed 247 pounds, while Valerie weighed 235 pounds.*
- Who is losing weight faster?

3. Mr. Rich recently planted a crop of money trees in his garden.

**A.**  
 The first tree was five inches tall when planted. It has grown four inches every month since being planted.

**B.**  
 Measurements were taken of the second tree and given below:

Months	0	2	3	5
Height	3	12	16.5	25.5

**C.**

Time (Months)	Tree A Height (inches)	Tree B Height (inches)	Tree C Height (inches)
0	5	3	10
1	9	7.5	13.5
2	13	12	17
3	17	16.5	20.5
4	21	21	24
5	25	25.5	27.5
6	29	30	31
7	33	34.5	34.5
8	37	39	38

- Which of the trees is growing the fastest?  
*Tree B. It is growing 4.5 inches per month; Tree A grows 4  $\frac{\text{in}}{\text{mo}}$  and Tree C grows 3.5  $\frac{\text{in}}{\text{mo}}$ .*
- Which tree was the tallest when it was first planted?  
*Tree C. It was 10 inches tall when planted. Tree A was 5 inches, and Tree B was 3 inches.*
- Challenge: Which tree is the tallest after 6 months?  
*Tree C. It will be 31 inches tall. Tree A will be 29 inches tall, and Tree B will be 30 inches tall.*

4. Tony is the best pizza deliveryman in the city. He has been offered jobs by all the best pizza places.

**Bombinoes' Pizza** is offering \$56 per shift and \$2.50 in commission for each pizza delivered.

**Little Squeezer's** showed Tony a table of salaries.

Pizzas	0	2	4	10
Salary	48	54	60	78

**Pizza Tent** has given Tony his pay options in the following function.  $S$  represents Tony's salary, and  $p$  represents the number of pizzas he delivers.

$$S = 2.75p + 52$$

**Papa Ron's** made their offer in the form of this graph.

Pizzas Delivered	Salary
0	60
2	64
4	68
6	72
8	76
10	80

- Which company pays the best pay per shift?  
*Papa Ron's pays the best flat salary at \$60 per shift.*
- Which company pays the most per pizza?  
*Little Squeezer's pays the most per pizza at \$3 per pizza.*
- Challenge: If Tony is going to deliver at least 20 pizzas every night, which company should he work for? *He should work for Little Squeezer's. He will earn \$108 for delivering 20 pizzas. For 20 pizzas, Bombinoes' would pay \$106, Pizza Tent would pay \$107, and Papa Ron's would pay \$100. After this point Little Squeezer's will always be his best choice because it has the highest pay per pizza.*

## Closing Activity

Instruct students to complete Task #10: Lesson 3 Exit Ticket

INCLUDED IN THE STUDENT MANUAL

### Task #10: Lesson 3 Exit Ticket

1. The graph below represents the distance  $d$ , Car A travels in  $t$ , minutes. The table represents the distance  $d$ , Car B travels in  $t$ , minutes. Which car is traveling at a greater speed? How do you know?

Car A:

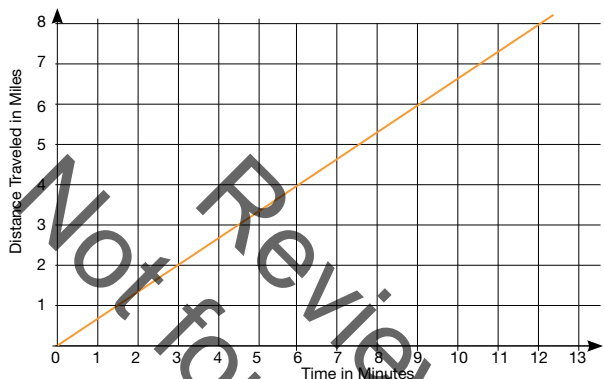

Car B:

$t$ , Time in minutes	$d$ , Distance in miles
15	12.5
30	25
45	37.5

2. How can you determine whether the relationship between time and distance for Car A is proportional or not? Be sure to thoroughly explain your reasoning.

---



---

3. How can you determine whether the relationship between time and distance for Car B is proportional or not? Be sure to thoroughly explain your reasoning.

---



---

### TEACHER ANSWER KEY Task #10: Lesson 3 Exit Ticket

1. Which car is traveling at a greater speed? How do you know?

*Car B is traveling at a greater speed than Car A. Car B is traveling at .67 miles/minute and Car B is traveling at 0.83 miles/minute.*

2. How can you determine whether the relationship between time and distance for Car A is proportional or not? Be sure to thoroughly explain your reasoning.

*Because the graph of Car A passes through the origin and has a constant rate of change, the relationship is proportional.*

3. How can you determine whether the relationship between time and distance for Car B is proportional or not? Be sure to thoroughly explain your reasoning.

*The relationship between distance and time for each coordinate pair is consistently 0.83 meaning that there is a constant rate of change. And because the distance in 0 minute is 0 miles, the relationship is proportional.*

**Resources/Instructional Materials Needed:**

---

Task #7: Yard Work

Task #8: Music Downloads

Task #9: Comparing Functions

Task #10: Lesson 3 Exit Ticket

computer with internet access and projector

graph paper

rulers

<https://www.youtube.com/watch?v=6AjBsO4qsw>

<http://bit.ly/1ZeHrns>

<http://bit.ly/1VWYOZR>

**Notes:**

Not for Review Copy  
Distribution

## Functions and Linear Relationships

# Lesson 4 of 9

## Linear Functions in Context Part 1

### College- and Career-Readiness Standards Addressed:

---

Use functions to model relationships between quantities.

- F.4 Construct a function to model a linear relationship between two quantities. Determine the rate of change and initial value of the function from a description of a relationship or from two  $(x, y)$  values, including reading these from a table or from a graph. Interpret the rate of change and initial value of a linear function in terms of the situation it models, and in terms of its graph or a table of values.

### Process Readiness Indicators:

---

- PRI 1: Make sense of problems and persevere in solving through reasoning and exploration.
- PRI 2: Reason abstractly and quantitatively by using multiple forms of representations to make sense of and understand mathematics.
- PRI 3: Describe and justify mathematical understandings by constructing viable arguments, critiquing the reasoning of others and engaging in meaningful mathematical discourse.
- PRI 4: Contextualize mathematical ideas by connecting them to real-world situations. Model with mathematics.
- PRI 5: Attend to precision.

Sequence of  
Instruction

Activities Checklist

### Engage

---

**PRI 1**  
**PRI 4**  
**PRI 6**

In this activity, students will make sense of a real-world problem that can be modeled with linear relationships. Provide students with graph paper, rulers, and colored pencils to complete Task #11: Rental Trucks Part 1 from the student manual. Ask students to complete #1, 2, and 3 only. Students should attend to precision when completing their graphs. Then, as a class, discuss the problem. Select student work to display with a document camera. Because students often have trouble determining a scale when graphing, you may want to look for students who use different scales in order to compare in the whole-group discussion.

INCLUDED IN THE STUDENT MANUAL

### Task #11: Rental Trucks Part 1

The table below shows the charge to rent a moving truck from Economy Rentals and Reliable Rentals for various numbers of miles.

miles	Economy Rentals	Reliable Rentals
10	\$15	\$60
30	\$45	\$70
50	\$75	\$80

1. Based on the information given in the table, explain how you might find the charge for 20 miles driven with each rental company.

\_\_\_\_\_

\_\_\_\_\_

2. Create a graph relating number of miles driven and rental cost for each company on the coordinate plane.

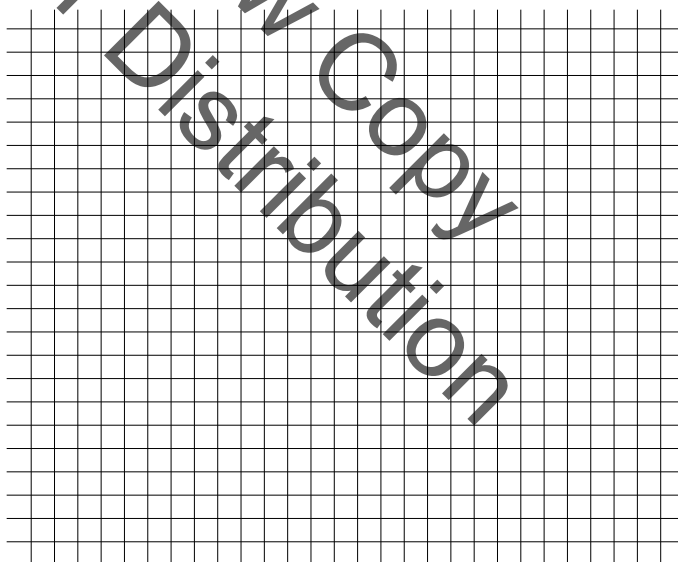

3. Which company do you think would be the better choice for a 100 mile trip?

\_\_\_\_\_

\_\_\_\_\_

4. Describe the relationship between number of miles and the rental charges as seen in the graphs.

\_\_\_\_\_

\_\_\_\_\_

5. Use the graph to give an estimate for the numbers of miles that would give a \$135 charge for each company.

---

---

6. What is the rental charge per mile for each company? How/where do you see the rental charge per mile in the graph?

---

---

7. Where does each graph intersect the vertical axis? Are they the same? Why or why not?

---

---

8. Write an equation for each company that could be used to determine the rental charge for any number of miles driven.

---

---

9. Where do you see the rental charge per mile in the equations?

---

---

10. What is the meaning of each y-intercept in the context of the situation?

---

---

11. Use your equations to calculate the rental charges for 100 miles for each company. Do the answers support what you predicted in #3?

---

---

---

**Note to teacher:** Encourage students to leave extra room on their graph because they will be asked to extrapolate for values beyond those given in the table. For students who have trouble getting started, encourage them to use problem-solving strategies (e.g. Polya's Problem Solving) to make sense of the problem.

Possible questions to pose to students:

- What difficulties did you face creating the graphs?
- What variable did you graph on the horizontal axis? What variable did you graph on the vertical axis?
- How would the graph support your answers for #1 and #3?

### Explore

**PRI 1**  
**PRI 4**  
**PRI 6**

When all students have the correct graph and have predicted the better rental company for a 100-mile trip, ask students to complete #4 – 11 on Task #11: Rental Trucks Part 1 in the student manual. In this task, the students will examine the concept of rate of change and y-intercepts in the context of the real-world Rental Trucks situation.

While rotating around the room to provide support, encourage students to attend to precision while discussing in small groups and when answering the questions in writing. Specifically, listen for precise mathematical language and redirect when students are not using appropriate vocabulary.

#### TEACHER ANSWER KEY Task #11: Rental Trucks Part 1

The table below shows the charge to rent a moving truck from Economy Rentals and Reliable Rentals for various numbers of miles.

miles	Economy Rentals	Reliable Rentals
10	\$15	\$60
30	\$45	\$70
50	\$75	\$80

1. Based on the information given in the table, explain how you might find the charge for 20 miles driven with each rental company.

*Answers will vary.*

2. Create a graph relating number of miles driven and rental cost for each company on the coordinate plane.
3. Which company do you think would be the better choice for a 100 mile trip?

Chart Title

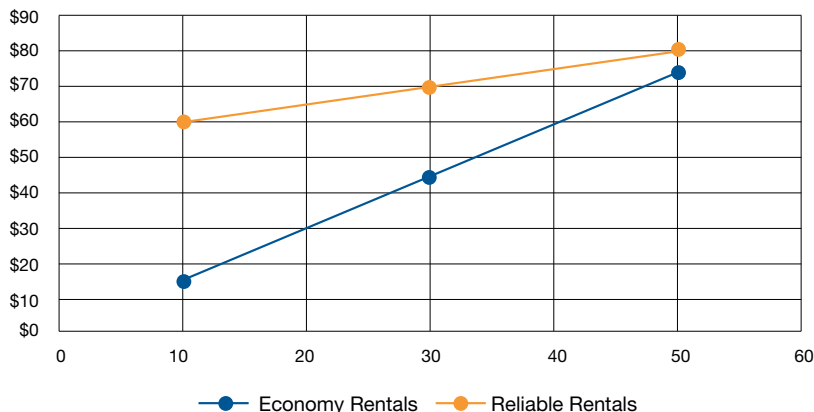



*Reliable Rentals*

4. Describe the relationship between number of miles and the rental charges as seen in the graphs.

*Answers vary but generally should include that rental charges increase as more miles are driven.*

5. Use the graph to give an estimate for the numbers of miles that would give a \$135 charge for each company.

*Economy Rentals would charge \$135 for 90 miles driven. Reliable Rentals would charge \$135 for 160 miles driven.*

6. What is the rental charge per mile for each company? How/where do you see the rental charge per mile in the graph?

*Economy Rentals charges \$1.50 per mile, and Reliable Rentals charges \$0.50 per mile. This rate is the slope of the line.*

7. Where does each graph intersect the vertical axis? Are they the same? Why or why not?

*The line for Economy Rentals would cross the vertical axis at zero (origin), and the Reliable Rentals line would cross at 55. They are not the same because based on the data, Reliable Rentals must have an initial charge of \$55 while Economy Rentals just charges a per mile fee.*

8. Write an equation for each company that could be used to determine the rental charge for any number of miles driven.

*Economy Rentals  $y = 1.5x$       Reliable Rentals  $y = 0.5x + 55$*

9. Where do you see the rental charge per mile in the equations?

*The rental charge per mile is the coefficient on  $x$  or the slope of the line.*

10. What is the meaning of each  $y$ -intercept in the context of the situation?

*The  $y$ -intercept is the initial cost or base price for a rental.*

11. Use your equations to calculate the rental charges for 100 miles for each company. Do the answers support what you predicted in #3?

*Economy Rentals \$150      Reliable Rentals \$105*

## Explanation

---

### PRI 2

**Whole Group Discussion:** After the students have completed the task, lead a class discussion of the answers emphasizing the patterns of linear relationships as found in tabular data, graphs, and equations. This is also the time to discuss any misconceptions that may have arisen during the work period.

During the discussion, make sure to compare the rental charge per mile on the graph (#6) with the rental charge in the equations (#9). Students need to understand linear relationships in all representations—tables, graphs, equations, and verbal descriptions. Likewise, students should be able to determine the most appropriate representation to use in order to answer a given question.

Possible questions:

- How do the equations and the graphs represented for each rental company differ?
- Which representation of the situation would be best in order to determine the rental costs for 42 miles driven? 75 miles? 350 miles?

## Practice in Small Groups

---

Working in pairs, students will complete the Linear Sorting and Matching Activity. The students will match multiple representations of equivalent linear relationships presented as a card sort activity. This activity can also be found at:

<https://nphs-math.wikispaces.com/file/view/Linear-Sorting-and-Matching.pdf>

Begin by giving each pair of students only the graphs and tables to match. Students should take turns matching a graph to a table and should use precise mathematical language when justifying reasoning to their partner. Ask students to record their matches on the chart provided with the activity. After the graphs and tables have been matched, give pairs one set of the remaining cards at a time beginning with the slope and y-intercept cards, then the equations, and lastly, the descriptions.

## Closing Activity

---

### PRI 3

After each pair has matched all the cards, ask students to compare their matches recorded on the chart with another pair's matches. If there are any discrepancies, students must justify their mathematical reasoning for the matches in question. If there are any disagreements on matches left unresolved, a short whole-group discussion may be needed at this point.

## Evaluate Understanding

---

### 3-2-1 Exit Ticket

Ask the students to complete a 3-2-1 Exit Ticket writing:

3 things you already knew about linear relationships

2 things you learned today

1 thing in which you need more practice

### Resources/Instructional Materials Needed

---

Task #11: Rental Trucks Part 1

Linear Sorting and Matching Activity Cards - one set of cards printed and cut for each pair of students

document camera and projector

graph paper

rulers

colored pencils

<https://nphs-math.wikispaces.com/file/view/Linear-Sorting-and-Matching.pdf>

### Notes:

Review Copy  
Not for Distribution

## Blackline Master

### Linear Sorting and Matching

#### Notes to teachers:

#### **SORTS:**

The 10 linear equation graphs can be sorted according to characteristics that they share.

The 10 equations can also be sorted according to characteristics that they share.

#### **MATCHING**

Here are some suggestions for how to use the 4 sets of cards as matching activities:

Match each graph with its equation.

Match each graph with its table of values.

Match each graph with its slope and y-intercept card.

Match each graph with its equation, table of values, slope & y-intercept, and description cards.

**Blackline Master**

## LINEAR SORTING AND MATCHING

Work with your partner(s) to match each graph to its Equation, Slope & Y-Intercept, Table of Values, and Description

GRAPH	EQUATION	SLOPE & Y-INTERCEPT	TABLE OF VALUES	DESCRIPTION
A				
B				
C				
D				
E				
F				
G				
H				
I				
J				

Not for Review Copy  
Distribution

Blackline Master

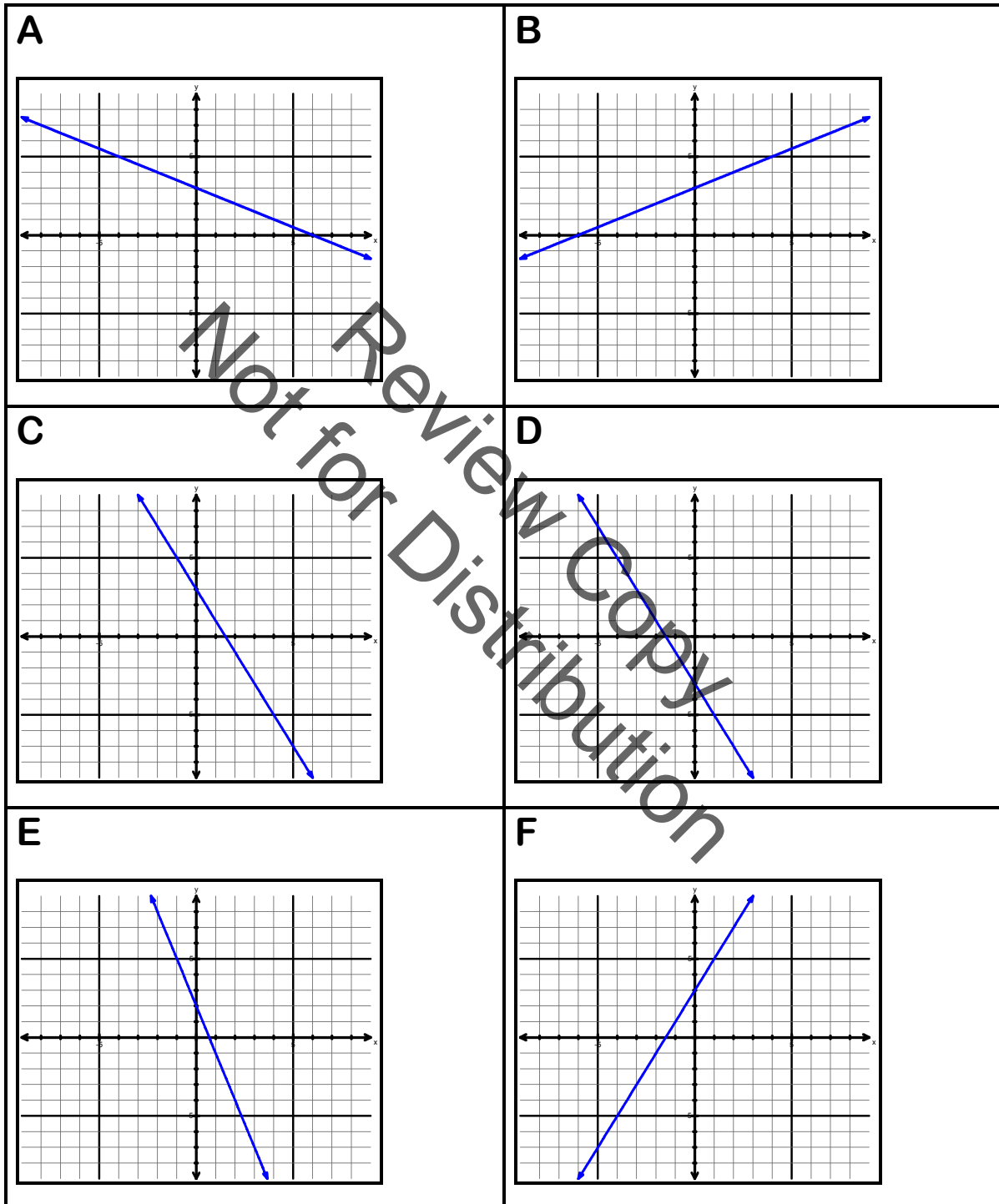

Blackline Master

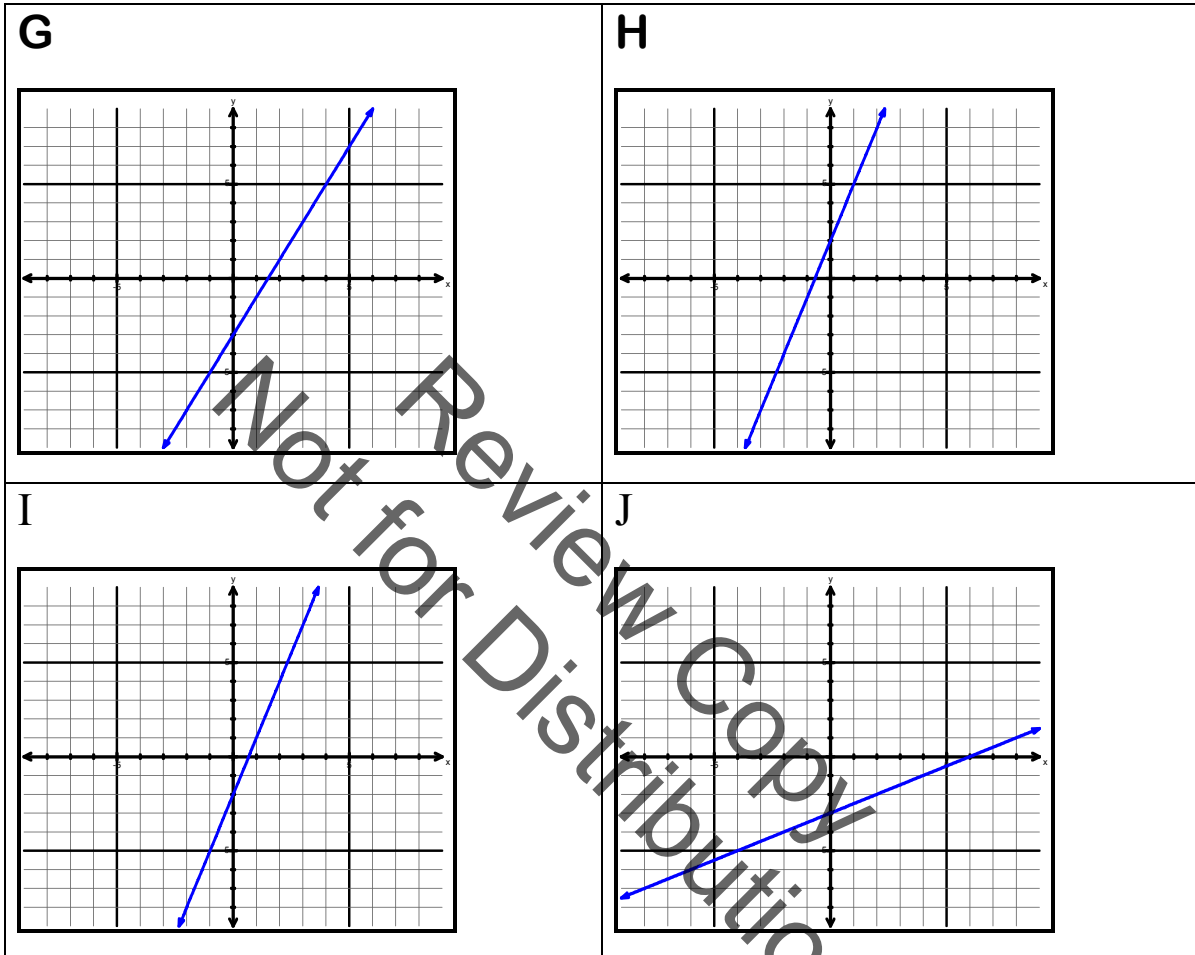

Blackline Master

1 $y = -3 + \frac{1}{2}x$	2 $y = -3x + 2$
3 $2x - y = 3$	4 $3x - y = -2$
5 $y = -2x - 3$	6 $2x + y = 3$
7 $x + 2y = 6$	8 $y = 2x + 3$
9 $y = -2 + 3x$	10 $y = \frac{1}{2}x + 3$



Blackline Master

11 slope: 2 y-intercept: 3	12 slope: 2 y-intercept: -3
13 slope: -2 y-intercept: -3	14 slope: 3 y-intercept: -2
15 slope: $\frac{1}{2}$ y-intercept: -3	16 slope: -2 y-intercept: 3
17 slope: $\frac{1}{2}$ y-intercept: 3	18 slope: $-\frac{1}{2}$ y-intercept: 3
19 slope: -3 y-intercept: 2	20 Slope: 3 y-intercept: 2

Blackline Master

<p>21</p> <table border="1"><tr><td><math>x</math></td><td>-2</td><td>0</td><td>2</td><td>4</td></tr><tr><td><math>y</math></td><td>-4</td><td>-3</td><td>-2</td><td>-1</td></tr></table>	$x$	-2	0	2	4	$y$	-4	-3	-2	-1	<p>22</p> <table border="1"><tr><td><math>x</math></td><td>-2</td><td>0</td><td>2</td><td>4</td></tr><tr><td><math>y</math></td><td>-4</td><td>2</td><td>8</td><td>14</td></tr></table>	$x$	-2	0	2	4	$y$	-4	2	8	14
$x$	-2	0	2	4																	
$y$	-4	-3	-2	-1																	
$x$	-2	0	2	4																	
$y$	-4	2	8	14																	
<p>23</p> <table border="1"><tr><td><math>x</math></td><td>-2</td><td>0</td><td>2</td><td>4</td></tr><tr><td><math>y</math></td><td>-1</td><td>3</td><td>7</td><td>11</td></tr></table>	$x$	-2	0	2	4	$y$	-1	3	7	11	<p>24</p> <table border="1"><tr><td><math>x</math></td><td>-2</td><td>0</td><td>2</td><td>4</td></tr><tr><td><math>y</math></td><td>-7</td><td>-3</td><td>1</td><td>5</td></tr></table>	$x$	-2	0	2	4	$y$	-7	-3	1	5
$x$	-2	0	2	4																	
$y$	-1	3	7	11																	
$x$	-2	0	2	4																	
$y$	-7	-3	1	5																	
<p>25</p> <table border="1"><tr><td><math>x</math></td><td>-2</td><td>0</td><td>2</td><td>4</td></tr><tr><td><math>y</math></td><td>7</td><td>3</td><td>-1</td><td>-5</td></tr></table>	$x$	-2	0	2	4	$y$	7	3	-1	-5	<p>26</p> <table border="1"><tr><td><math>x</math></td><td>-2</td><td>0</td><td>2</td><td>4</td></tr><tr><td><math>y</math></td><td>2</td><td>3</td><td>4</td><td>5</td></tr></table>	$x$	-2	0	2	4	$y$	2	3	4	5
$x$	-2	0	2	4																	
$y$	7	3	-1	-5																	
$x$	-2	0	2	4																	
$y$	2	3	4	5																	
<p>27</p> <table border="1"><tr><td><math>x</math></td><td>-2</td><td>0</td><td>2</td><td>4</td></tr><tr><td><math>y</math></td><td>-8</td><td>-2</td><td>4</td><td>10</td></tr></table>	$x$	-2	0	2	4	$y$	-8	-2	4	10	<p>28</p> <table border="1"><tr><td><math>x</math></td><td>-2</td><td>0</td><td>2</td><td>4</td></tr><tr><td><math>y</math></td><td>8</td><td>2</td><td>-4</td><td>-10</td></tr></table>	$x$	-2	0	2	4	$y$	8	2	-4	-10
$x$	-2	0	2	4																	
$y$	-8	-2	4	10																	
$x$	-2	0	2	4																	
$y$	8	2	-4	-10																	
<p>29</p> <table border="1"><tr><td><math>x</math></td><td>-2</td><td>0</td><td>2</td><td>4</td></tr><tr><td><math>y</math></td><td>4</td><td>3</td><td>2</td><td>1</td></tr></table>	$x$	-2	0	2	4	$y$	4	3	2	1	<p>30</p> <table border="1"><tr><td><math>x</math></td><td>-2</td><td>0</td><td>2</td><td>4</td></tr><tr><td><math>y</math></td><td>1</td><td>-3</td><td>-7</td><td>-11</td></tr></table>	$x$	-2	0	2	4	$y$	1	-3	-7	-11
$x$	-2	0	2	4																	
$y$	4	3	2	1																	
$x$	-2	0	2	4																	
$y$	1	-3	-7	-11																	

**Blackline Master**

<b>31</b> <b>This graph has the same slope as graph B.</b>	<b>32</b> <b>This graph has the steepest negative slope.</b>
<b>33</b> <b>This graph has a negative slope and a negative <math>y</math>-intercept.</b>	<b>34</b> <b>This line represented by this graph is perpendicular to graphs F and G.</b>
<b>35</b> <b>This graph passes through <math>(-1, -1)</math> and has positive slope.</b>	<b>36</b> <b>The line represented by this graph is parallel to graph F.</b>
<b>37</b> <b>This graph passes through the point <math>(0, -2)</math>.</b>	<b>38</b> <b>This equation represented by this graph is equivalent to <math>x - 2y = -6</math>.</b>
<b>39</b> <b>The line represented by this graph is parallel to graph D.</b>	<b>40</b> <b>The <math>x</math>-intercept of the line represented by this graph is between <math>-1</math> and <math>-2</math> and its slope is positive.</b>

**Blackline Master**

**LINEAR SORTING AND MATCHING**

**ANSWER SHEET**

GRAPH	EQUATION	SLOPE & Y-INTERCEPT	TABLE OF VALUES	DESCRIPTION
A	7	18	29	34
B	10	17	26	38
C	6	16	25	39
D	5	13	30	33
E	2	19	28	32
F	8	11	23	40
G	3	12	24	36
H	4	20	22	35
I	9	14	27	37
J	1	15	21	31

## Functions and Linear Relationships

# Lesson 5 of 9

## Linear Functions in Context Part 2

### College- and Career-Readiness Standards Addressed:

Use functions to model relationships between quantities.

- F.4 Construct a function to model a linear relationship between two quantities. Determine the rate of change and initial value of the function from a description of a relationship or from two  $(x, y)$  values, including reading these from a table or from a graph. Interpret the rate of change and initial value of a linear function in terms of the situation it models, and in terms of its graph or a table of values.

### Process Readiness Indicators:

- PRI 1: Make sense of problems and persevere in solving through reasoning and exploration.
- PRI 4: Contextualize mathematical ideas by connecting them to real-world situations. Model with mathematics.
- PRI 6: Attend to precision.

Sequence of  
Instruction

Activities Checklist

### Engage

**PRI 1**  
**PRI 4**  
**PRI 6**

Provide students with Task #12: Rental Trucks Part 2 from the student manual and graph paper, as an optional tool. Ask students to read and make sense of the problem and answer #1 and #2. Listen carefully to students' use of mathematical language as you rotate around to each group.

**Note to teacher:** It is important that students make a connection between a table of values, like the one seen in Rental Trucks Part 1, and a written description, such as the one in Rental Trucks Part 2. Students should be able to write this information as ordered pairs,  $J(10, 29)$  and  $M(30, 69)$ , and see the relationship between these ordered pairs and the table of values in Rental Trucks Part 1. If students are struggling to make this connection, it may be necessary to show students how they relate in the table below. (Students will see this table in the closing of the lesson but showing it now, may help students make sense of Part 2 of this problem).

miles	Economy Rentals	Reliable Rentals	Regal Rentals
10	\$15	\$60	\$29
30	\$45	\$70	\$69
50	\$75	\$80	

INCLUDED IN THE STUDENT MANUAL

### Task #12: Rental Trucks Part 2

Janet and Marcus each rented a moving truck from Regal Rentals on the same day. Janet was charged \$29 for a 10 mile trip and Marcus was charged \$69 for a 30 mile trip.

1. What information is needed to write an equation to model the rental charge for any amount of miles for Regal Rentals?

---

---

---

2. List at least two ways to find that information.

---

---

3. Now, write an equation to model the rental charge for any amount of miles for Regal Rentals.

---

4. Use your equation to find the charge for a 150 mile trip.

---

5. What does the y-intercept in your equation mean in the context of the situation?

---

---

6. What does the slope in your equation mean in the context of the situation?

---

---

Not for Review Copy  
Distribution

**Whole Group Discussion:** Engage students in a discussion about their answers to #1 and #2. Students should be encouraged to use correct mathematical language throughout this discussion. From the previous lesson, students should know that both the slope and y-intercept are needed in order to write an equation of a line, but students may or may not remember the slope formula. Encourage students to understand slope as the vertical difference of two points divided by the horizontal difference of those two points rather than simply memorizing the formula. This would also be an appropriate time to reiterate that the y-intercept is an initial value or starting point, but allow students to interpret the meaning of the y-intercept in the task rather than discuss it here.

## Explore

**PRI 1**  
**PRI 4**  
**PRI 6**

After each group has shared their plan for finding the slope and y-intercept of the line, instruct students to utilize the methods discussed in #2 to complete the task (#3 - 6). For the remaining parts in this task, the students will be modeling the real-world situation provided in the problem with a linear equation making sense of the slope and y - intercept in the concept of this problem.

**Note to teacher:** At this point, we want to students to be able to write the equation of the line without plotting the points and using the graph, however, some students may still need to “see” the slope and the y-intercept. For students that are solely using this method, make sure they are able to use the slope formula to find the slope and then use slope-intercept form of the line to solve for b algebraically. Keep an eye out for students who may use point-slope formula. This method is discussed later in the lesson.

## Explanation

**PRI 1**  
**PRI 4**  
**PRI 6**

**Think-Pair-Share:** Display the two formulas on the board and pose the following question:

$$m = \frac{y_2 - y_1}{x_2 - x_1} \quad \text{and} \quad y - y_1 = m(x - x_1)$$

*What is the relationship between the slope formula and point-slope formula?*

For the students to make sense of the point-slope formula, they need to know point-slope formula as simply a way to rewrite the slope formula rather than memorizing it. Students may or may not remember point-slope formula from their previous experience with linear functions so this is an opportunity to help them understand it conceptually.

**Whole-Group Discussion:** Allow students to share their work and solutions to #3 and #4 using a document camera, if available. Select students so that all the different methods for writing an equation are represented including graphing as a method. This discussion should allow students to see the connections between the different algebraic methods and the graphical representation of the function. Conclude the discussion by asking students to share their interpretation of the slope and y-intercept in the context of the Rental Truck problem, #5 and #6.

**TEACHER ANSWER KEY** Task #12: Rental Trucks Part 2

Janet and Marcus each rented a moving truck from Regal Rentals on the same day. Janet was charged \$29 for a 10 mile trip and Marcus was charged \$69 for a 30 mile trip.

1. What information is needed to write an equation to model the rental charge for any amount of miles for Regal Rentals?

*Rental cost per mile (slope) and base or initial charge ( $y$  – intercept)*

2. List at least two ways to find that information.

*This information can be calculated with formulas from the given information or obtained by creating a graph of the given information.*

3. Now, write an equation to model the rental charge for any amount of miles for Regal Rentals.

$$y = 2x + 9$$

4. Use your equation to find the charge for a 150 mile trip.

*\$309*

5. What does the  $y$ -intercept in your equation mean in the context of the situation?

*The  $y$ -intercept is the base or initial rental charge.*

6. What does the slope in your equation mean in the context of the situation?

*The slope is the rental fee per mile.*

### Independent Practice

**PRI 6**

Ask students to complete Task #13: Writing Equations Practice from the student manual independently. In this activity, students will attend to precision to reinforce the concepts they have learned in this lesson. This is also an opportunity to differentiate instruction if there are a small number of students still struggling with the concept. These students may need more of the same type of each of the six problems for practice. They may also benefit from being paired with another student.

For students who correctly complete this practice and need an enrichment activity, ask them to graph the data from Rental Trucks Part 2 on the graph from Rental Trucks Part 1 and determine which rental company is best.



INCLUDED IN THE STUDENT MANUAL

**Task #13: Writing Equations Practice**

1. Write an equation for the line with a y-intercept of -5 and a slope of  $-\frac{1}{3}$ .

2. Identify the slope and y-intercept for each linear equation.

a.  $y = 2x - 5$

b.  $y = x + 3$

c.  $y = -\frac{2}{5}x$

d.  $2x - y = 8$  (Hint: rewrite in slope-intercept form  $y = mx + b$  by solving for  $y$ .)

Use the table for #3 - 5.

x	y
-2	7
1	1
2	-1

3. Calculate the rate of change or slope for the data in the table above.

4. What is the value for  $y$  when  $x = 0$  in the table?

5. Write an equation in slope-intercept form for the data in the table.

6. Write the slope-intercept form of the equation of the line passing through the points (4, -3) and (-6, -8).

**Evaluate Understanding**

**Whole Group Discussion:** Display the solutions to the Writing Equations Practice. It may not be necessary to go over and discuss each of these problems, rather, focus the discussion on problems commonly missed and any misconceptions revealed during the work period. The focus of this lesson most closely relates to #6 in this practice so it is advised to work this problem and reiterate the different methods for writing the equation. Circulate the room to see each student's work on #6 in order to informally evaluate their understanding of the lesson.

**TEACHER ANSWER KEY** Task #13: Writing Equations Practice

1. Write an equation for the line with a y-intercept of -5 and a slope of  $-\frac{1}{3}$ .

$$y = -\frac{1}{3}x - 5$$

2. Identify the slope and y-intercept for each linear equation.

a.  $y = 2x - 5$       slope: 2      y-int: -5

b.  $y = x + 3$       slope: 1      y-int: 3

c.  $y = -\frac{2}{5}x$       slope:  $-\frac{2}{5}$       y-int: 0

d.  $2x - y = 8$       slope: 2      y-int: -8

Use the table for #3 - 5.

	y
-2	7
1	0
2	-1

3. Calculate the rate of change or slope for the data in the table above.

-2

4. What is the value for y when  $x = 0$  in the table?

3

5. Write an equation in slope-intercept form for the data in the table.

$$y = -2x + 3$$

6. Write the slope-intercept form of the equation of the line passing through the points (4, -3) and (-6, -8).

$$y = \frac{1}{2}x - 5$$

### Closing Activity

**PRI 1**  
**PRI 4**  
**PRI 6**

Students should complete Task #14: Comparing Prices from the student manual as a closer to this lesson. Make sure students read the directions carefully to make sense of the problem. This activity is a final look at the real-world Rental Truck problem. The students should select a method and attend to precision to complete the table. Emphasize to the students that the reasoning given for the method chosen is just as important as their ability to correctly calculate the missing table values.



## Functions and Linear Relationships

# Lesson 6 of 9

## How *Do* Variables Vary?

### College- and Career-Readiness Standards Addressed:

Use functions to model relationships between quantities.

- F.4 Construct a function to model a linear relationship between two quantities. Determine the rate of change and initial value of the function from a description of a relationship or from two  $(x, y)$  values, including reading these from a table or from a graph. Interpret the rate of change and initial value of a linear function in terms of the situation it models, and in terms of its graph or a table of values.
- F.5 Describe qualitatively the functional relationship between two quantities by analyzing a graph (e.g., where the function is increasing or decreasing, linear or nonlinear). Sketch a graph that exhibits the qualitative features of a function that has been described verbally.

### Process Readiness Indicators:

- PRI 1: Make sense of problems and persevere in solving through reasoning and exploration.
- PRI 3: Describe and justify mathematical understandings by constructing viable arguments, critiquing the reasoning of others and engaging in meaningful mathematical discourse.
- PRI 6: Attend to precision.

Sequence of  
Instruction

Activities Checklist

### Engage

**PRI 1**  
**PRI 6**

To help students understand the problem, this lesson begins with a demonstration of time versus distance graphs using a CBR motion detector (calculator based ranger). Ideally, each classroom has at least one CBR that the teacher can use as a demonstration. If there are enough CBR's for one per group, that's even better. Students must attend to precision as they follow the directions below that explain how to use the CBR with two people: a walker and a coach.

Step 1: Connect the CBR to the TI-84 calculator using the link cord. (The Vernier Easy Data application should begin automatically. If not, the application can be accessed by clicking APPS.)

Step 2: Click on Setup/Distance Match/Start. Follow the directions on the screen to match the graph. (Before beginning the walk, the walker and coach should study the graph and discuss what should take place. During the walk, the coach can give directions to help the walker get an accurate match.)

Step 3: After the walk is complete, examine how well your walk matched the graph. You will then have the option to either retry the walk with the same graph or get a new graph.

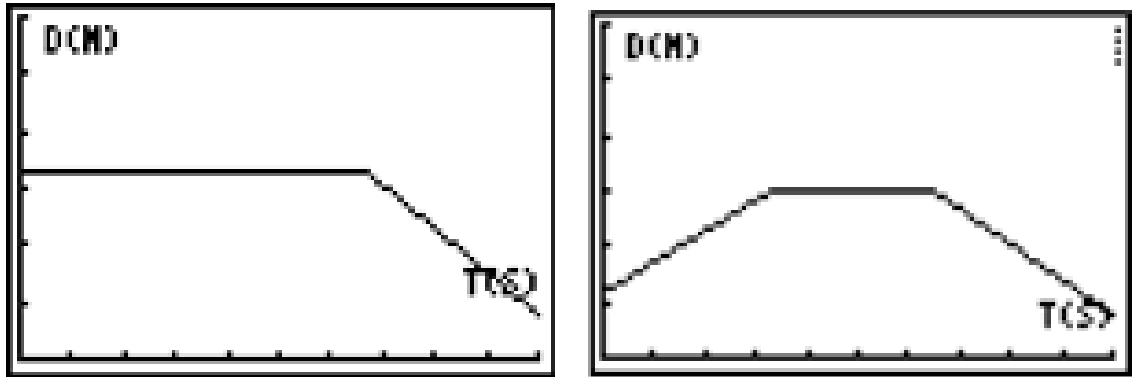

If you do not have access to a CBR, display the graphs above one at a time and allow students to discuss their interpretation of the graphs with an elbow partner. You will want to explain to students that graphs such as these are created when a motion detector placed at the origin measures a person's distance away from the detector. Ask students what units they think are represented on each axis. Hopefully, they will recognize the units as time in seconds and distance in meters.

Students should discuss the distance from the motion detector in which the walker begins, whether the walker is walking away from or towards the motion detector, and the speed at which she/he is walking. Students often think that a horizontal line indicates a walker walking at a constant rate rather than standing still so listen for this and other possible misconceptions.

## Explore

PRI 1  
PRI 3  
PRI 6

### Rally Coach: Walk the Line

(A blackline master for Rally Coach: Walk the Line can be found at the end of this lesson.)

Post these directions on the board for students to refer to during the activity. Students will attend to precision as they complete the activity.

**Directions for Rally Coach:** Students work in pairs. One student in each pair is given a graph. The other student must record the walking directions described by her/his partner. Students discuss and recorder states whether or not they agree. Next time, the other student receives a graph and her/his partner acts as recorder. The students will justify their mathematical reasoning and critique the reasoning of others as they discuss this activity.

**Note to teacher:** As the directions state, each pair of students should be given one graph from the Rally Coach activity. The teacher can choose to give the students the next graph when they are finished with the first or make additional graphs available for the students to get on their own when ready (for example, make them available in a folder on the table). The students, however, should be told that they will be held accountable for their work later on when asked to explain.

## Explanation

**PRI 3**  
**PRI 6**

**Student presentations:** Ask pairs of students to present one of their graphs to the class. Encourage students to use correct mathematical language when explaining their mathematical reasoning. If several students are struggling with the concept, you may need to go over all four of the graphs. If students are doing well, presenting on only one or two may be sufficient.

## Practice with a Partner

**PRI 1**  
**PRI 3**  
**PRI 6**

Instruct students to complete the first page of Task #15: Vincent's Graphs (#1 & #2) with a partner. Remind students to look carefully at the graph and read closely to understand and make sense of each problem. Encourage students to clearly articulate their own thinking and to be prepared to critique the reasoning of their partner.

INCLUDED IN THE STUDENT MANUAL

### Task #15: Vincent's Graphs

#### Vincent's Graphs

This problem gives you the chance to:

- interpret graphs
- draw a graph

Vincent is eating a packet of raisins.

This graph shows the changes in the mass of raisins in the packet as time passes.

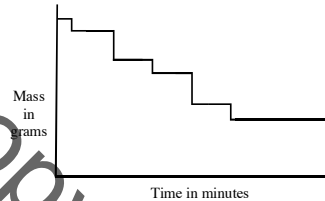

1. a. What is Vincent doing when there is a vertical line on the graph?

\_\_\_\_\_

b. Why are the vertical lines of different lengths?

\_\_\_\_\_

c. Did Vincent eat all the raisins? \_\_\_\_\_  
Explain how you know.

\_\_\_\_\_

2. Ellie is drinking with a straw from a box of fruit juice.

The graph shows the volume of juice in the box as time passes.

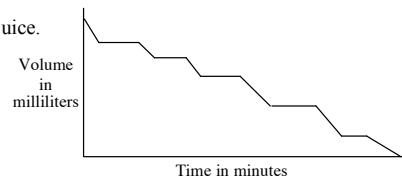

a. What is happening when the line on the graph is horizontal?

\_\_\_\_\_

b. Why do the lines going downwards on this graph go at an angle?

\_\_\_\_\_

**Whole Group Discussion:** Go over students' solutions to each of the two problems.

**TEACHER ANSWER KEY** Task #15: Vincent's Graph (#1 & #2)

The following are possible sample answers. Student responses will vary.

- 1a. He is taking raisins out of the packet.
- b. He takes different numbers of raisins from the packet.
- c. The line does not reach the x axis.
- 2a. Ellie is not drinking.
- b. The volume decreases steadily as the juice is sucked out.

### Evaluate Understanding/ Closing Activity

Ask students to complete Task #15: Vincent's Graph (#3) individually in order to formatively assess their understanding of the concept.

#### Task #15: Vincent's Graphs

- 3. Ralph is eating cherries from a bag.

After eating a cherry he puts the stone back into the bag before taking out the next cherry.

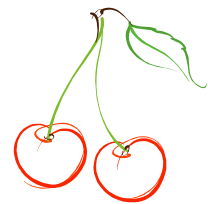

On the grid draw a graph to show the changes in the mass of the bag of cherries as time passes.

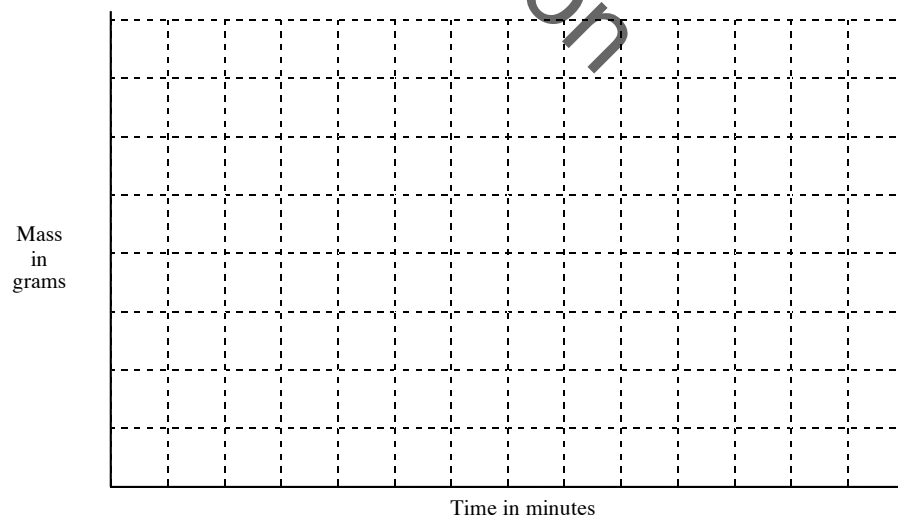





**Blackline Master – Rally Coach: Walk the Line**

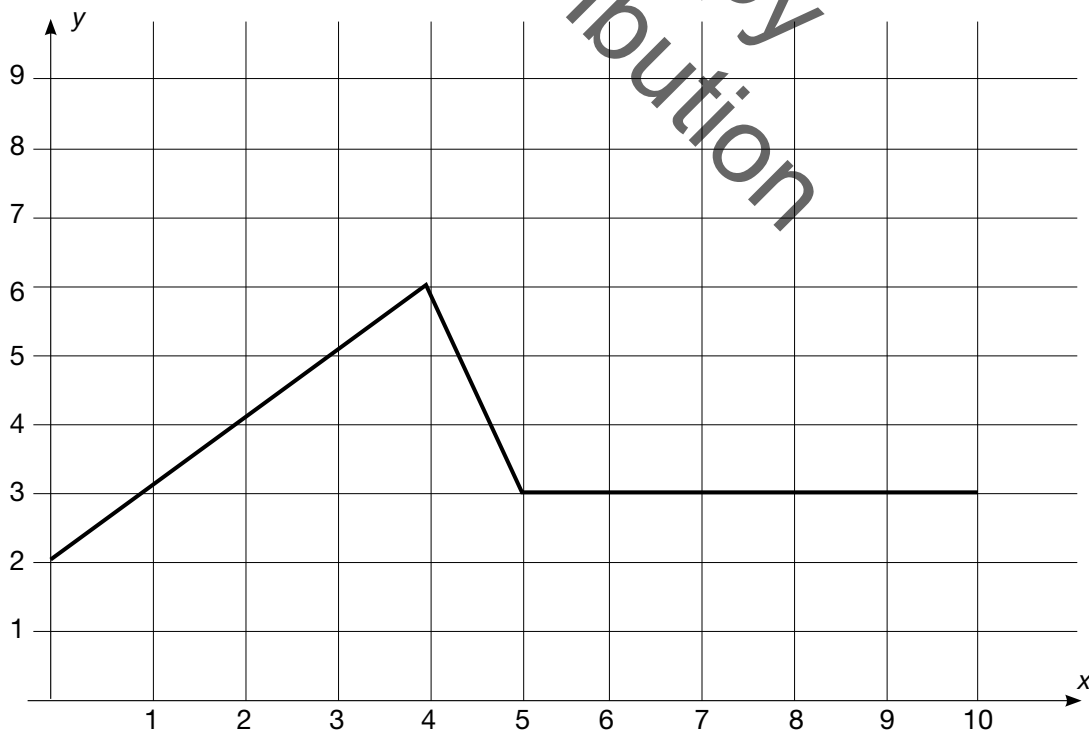
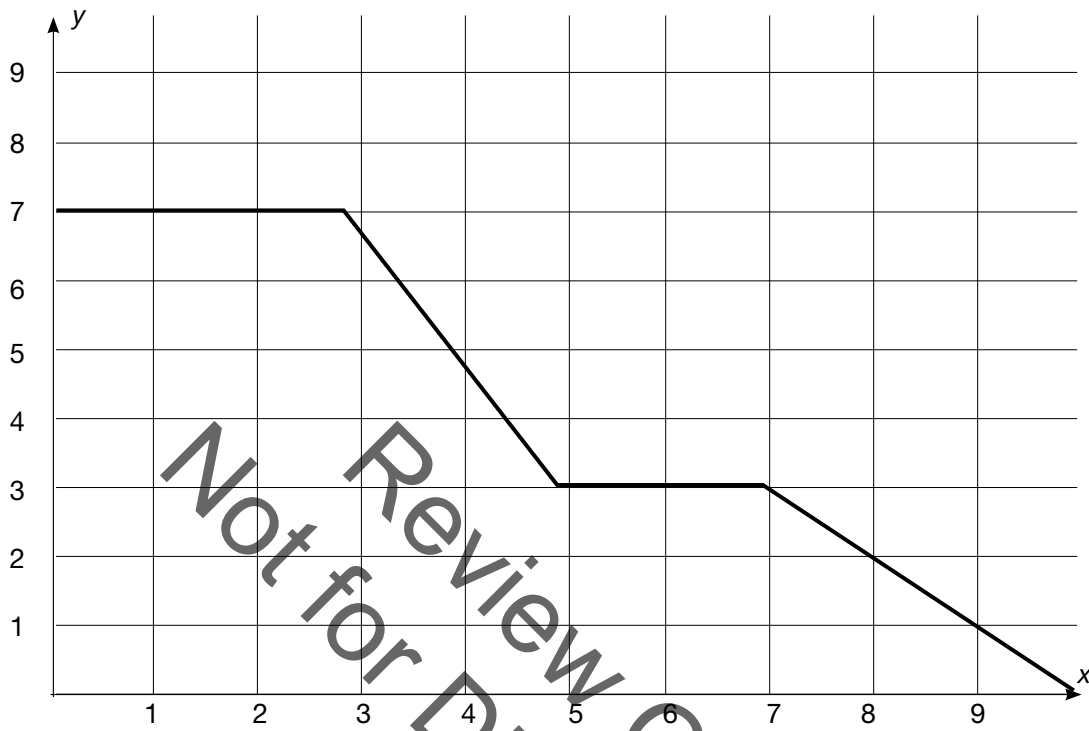

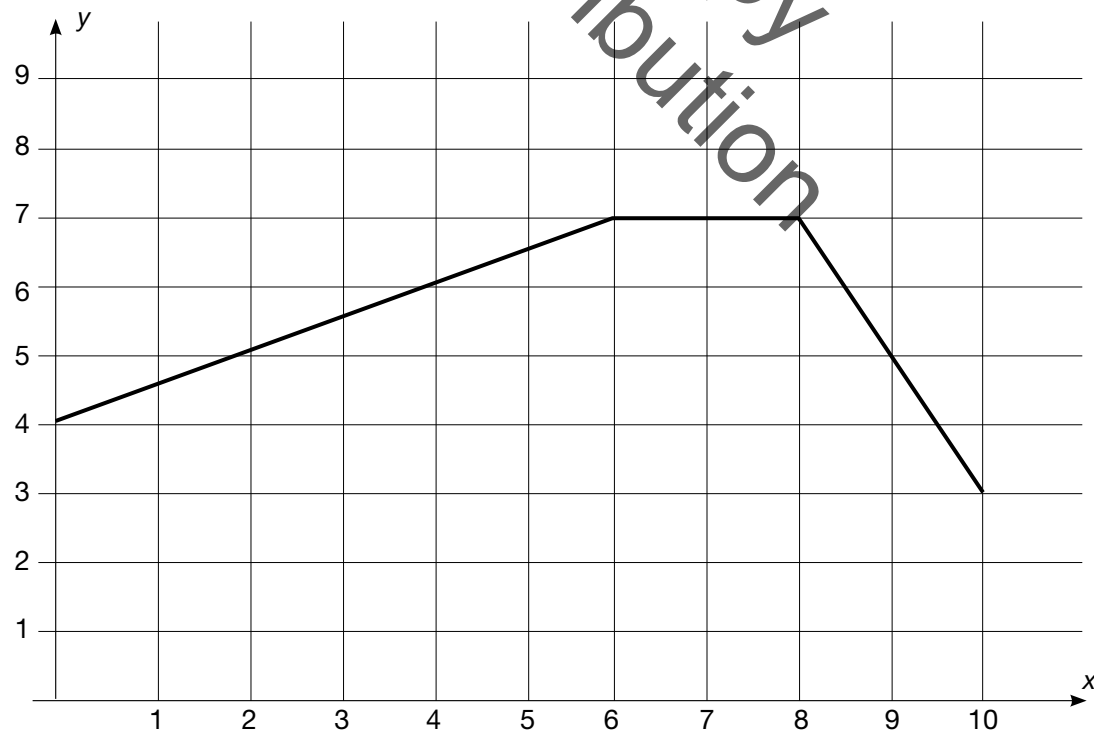
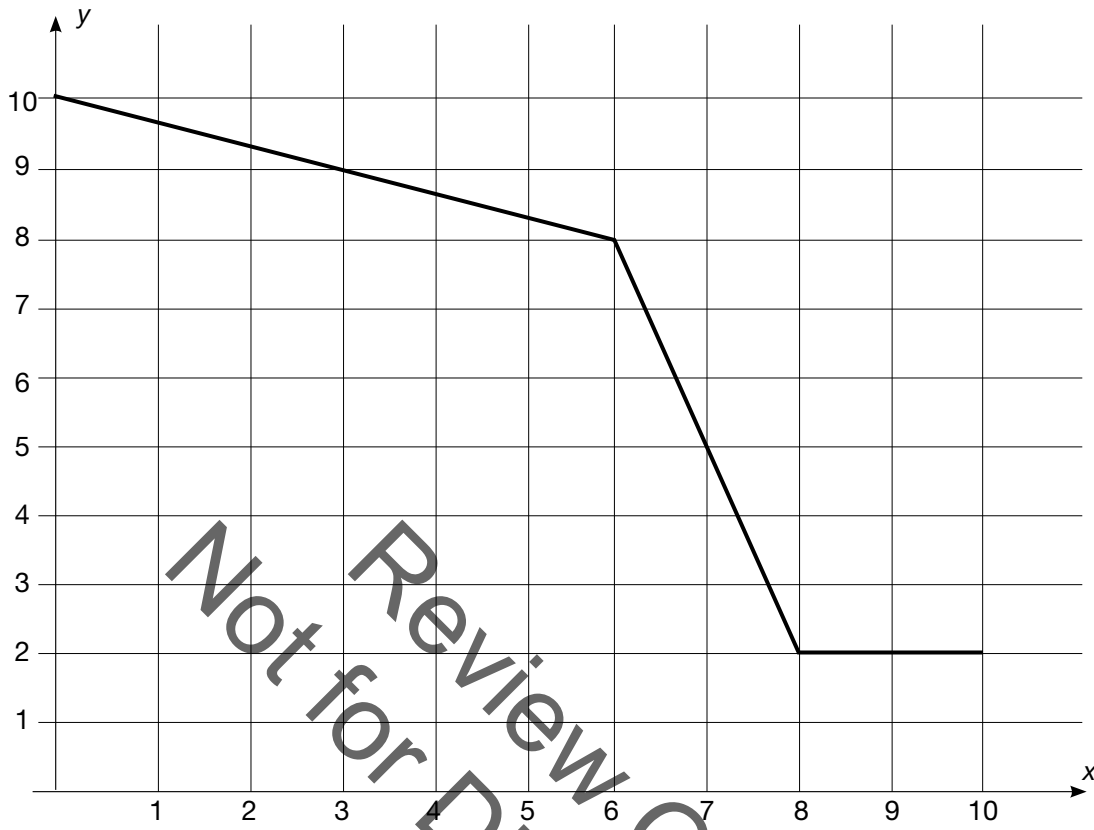

## Functions and Linear Relationships

# Lesson 7 of 9

## FAL: Interpreting Distance-Time Graphs

### College- and Career-Readiness Standards Addressed:

---

Use functions to model relationships between quantities.

- F.4 Construct a function to model a linear relationship between two quantities. Determine the rate of change and initial value of the function from a description of a relationship or from two  $(x, y)$  values, including reading these from a table or from a graph. Interpret the rate of change and initial value of a linear function in terms of the situation it models, and in terms of its graph or a table of values.
- F.5 Describe qualitatively the functional relationship between two quantities by analyzing a graph (e.g., where the function is increasing or decreasing, linear or nonlinear). Sketch a graph that exhibits the qualitative features of a function that has been described verbally.

### Process Readiness Indicators:

---

- PRI 1: Make sense of problems and persevere in solving through reasoning and exploration.
- PRI 2: Reason abstractly and quantitatively by using multiple forms of representations to make sense of and understand mathematics.
- PRI 3: Describe and justify mathematical understandings by constructing viable arguments, critiquing the reasoning of others and engaging in meaningful mathematical discourse.
- PRI 4: Contextualize mathematical ideas by connecting them to real-world situations. Model with mathematics.
- PRI 5: Use appropriate tools strategically to support thinking and problem solving.
- PRI 6: Attend to precision.
- PRI 7: Look for and make use of patterns and structure.
- PRI 8: Look for and express regularity in repeated reasoning.
- PRI 9: Demonstrate flexible use of strategies and methods while reflecting on which procedures seem to work best for specific types of problems.
- PRI 10: Reflect on mistakes and misconceptions to improve mathematical understanding.

The following *Formative Assessment Lesson* is a classroom-ready lesson included to help teachers assess and improve students' understanding of mathematical concepts and skills and their ability to use the mathematical process readiness indicators critical for college readiness.

Research has shown that formative assessment, as embodied in the following lesson, is a powerful way to improve student learning and performance. This approach first allows students to demonstrate their prior understandings and abilities in employing the mathematical processes, and then resolve their own difficulties and misconceptions through structured discussion. This results in more secure long-term learning, reducing the need for re-teaching that otherwise takes so much classroom time.

Many often ask, why don't students just remember the procedures they have been taught and practiced? The fact is, that approach works fine in the short term but, as every teacher knows, if procedural knowledge is not underpinned by conceptual understanding, students will quickly forget "how to do it."

Read more about the *Formative Assessment Lesson* rationale, structure, and philosophy using the *Brief Guide for Teachers and Administrators* that can be found at <http://map.mathshell.org/materials/index.php>.

Review Copy  
Not for Distribution

---

## CONCEPT DEVELOPMENT

---

Mathematics Assessment Project  
**CLASSROOM CHALLENGES**  
A Formative Assessment Lesson

# Interpreting Distance-Time Graphs

Mathematics Assessment Resource Service  
University of Nottingham & UC Berkeley

For more details, visit: <http://map.mathshell.org>  
© 2015 MARS, Shell Center, University of Nottingham  
May be reproduced, unmodified, for non-commercial purposes under the Creative Commons license  
detailed at <http://creativecommons.org/licenses/by-nc-nd/3.0/> - all other rights reserved

## BEFORE THE LESSON

### Assessment task: *Journey to the Bus Stop* (15 minutes)

Set this task, in class or for homework, a few days before the formative assessment lesson. This will give you an opportunity to assess the work, and to find out the kinds of difficulties students have with it. You will then be able to target your help more effectively in the next lesson.

Give each student a copy of *Journey to the Bus Stop*.

Briefly introduce the task and help the class to understand the problem and its context.

*Read through the task and try to answer it as carefully as you can.*

It is important that, as far as possible, students are allowed to answer the questions without your assistance.

Students should not worry too much if they cannot understand or do everything because in the next lesson they will engage in a similar task that should help them. Explain to students that by the end of the next lesson, they should expect to answer questions such as these confidently. This is their goal.

**Journey to the Bus Stop**

Every morning Tom walks along a straight road from his home to a bus stop, a distance of 160 meters. The graph shows his journey on one particular day.

Time (seconds)	Distance from home (meters)
0	0
50	100
70	40
100	160
120	160

1. Describe what may have happened. You should include details like how fast he walked.

.....

.....

.....

.....

.....

.....

2. Are all sections of the graph realistic? Fully explain your answer.

.....

.....

.....

### Assessing students' responses

Collect students' responses to the task. Make some notes on what their work reveals about their current levels of understanding and their different problem solving approaches.

We suggest that you do not score students' work. The research shows that this will be counterproductive, as it will encourage students to compare their scores and will distract their attention from what they can do to improve their mathematics.

Instead, help students to make further progress by summarizing their difficulties as a list of questions. Some suggestions for these are given in the *Common issues* table on the next page. We suggest that you make a list of your own questions, based on your students' work, using the ideas on the following page. We recommend you either:

- write one or two questions on each student's work,
- or
- give students a printed version of your list of questions highlighting the questions appropriate to each student.

If you do not have time to do this, you could select a few questions that will be of help to the majority of students and write these questions on the board when you return the work.

<b>Common issues:</b>	<b>Suggested questions and prompts:</b>
<p><b>Student interprets the graph as a picture</b></p> <p>For example: The student assumes that as the graph goes up and down, Tom’s path is going up and down.</p> <p>Or: The student assumes that a straight line on a graph means that the motion is along a straight path.</p> <p>Or: The student thinks the negative slope means Tom has taken a detour.</p>	<ul style="list-style-type: none"> <li>• If a person walked in a circle around their home, what would the graph look like?</li> <li>• If a person walked at a steady speed up and down a hill, directly away from home, what would the graph look like?</li> <li>• In each section of his journey, is Tom’s speed steady or is it changing? How do you know?</li> <li>• How can you figure out Tom’s speed in each section of the journey?</li> </ul>
<p><b>Student interprets graph as speed–time</b></p> <p>The student has interpreted a positive slope as speeding up and a negative slope as slowing down.</p>	<ul style="list-style-type: none"> <li>• If a person walked for a mile at a steady speed, away from home, then turned round and walked back home at the same steady speed, what would the graph look like?</li> <li>• How does the distance change during the second section of Tom’s journey? What does this mean?</li> <li>• How does the distance change during the last section of Tom’s journey? What does this mean?</li> <li>• How can you tell if Tom is traveling away from or towards home?</li> </ul>
<p><b>Student fails to mention distance or time</b></p> <p>For example: The student has not mentioned how far away from home Tom has travelled at the end of each section.</p> <p>Or: The student has not mentioned the time for each section of the journey.</p>	<ul style="list-style-type: none"> <li>• Can you provide more information about how far Tom has traveled during different sections of his journey?</li> <li>• Can you provide more information about how much time Tom takes during different sections of his journey?</li> </ul>
<p><b>Student fails to calculate and represent speed</b></p> <p>For example: The student has not worked out the speed of some/all sections of the journey.</p> <p>Or: The student has written the speed for a section as the distance covered in the time taken, such as “20 meters in 10 seconds.”</p>	<ul style="list-style-type: none"> <li>• Can you provide information about Tom’s speed for all sections of his journey?</li> <li>• Can you write his speed as meters per second?</li> </ul>
<p><b>Student misinterprets the scale</b></p> <p>For example: When working out the distance the student has incorrectly interpreted the vertical scale as going up in 10s rather than 20s.</p>	<ul style="list-style-type: none"> <li>• What is the scale on the vertical axis?</li> </ul>
<p><b>Student adds little explanation as to why the graph is or is not realistic</b></p>	<ul style="list-style-type: none"> <li>• What is the total distance Tom covers? Is this realistic for the time taken? Why?/Why not?</li> <li>• Is Tom’s fastest speed realistic? Is Tom’s slowest speed realistic? Why?/Why not?</li> </ul>

### SUGGESTED LESSON OUTLINE

If you have a short lesson or you find the lesson is progressing at a slower pace than anticipated, we suggest you break the lesson after the first sharing of posters and continue it at a later time.

#### Whole-class introduction: interpreting and sketching graphs (15 minutes)

Throughout this activity, encourage students to articulate their reasoning, justify their choices mathematically, and question the choices put forward by others. This introduction will provide students with a model of how they should work with their partners in the first small-group activity.

Show the class the projector resource *Matching a Graph to a Story*:

The projector resource is titled "Matching a Graph to a Story". It contains three story options (A, B, and C) and a graph. The graph has "Distance from home" on the vertical axis and "Time" on the horizontal axis. The graph shows a line that starts at the origin, rises with a shallow slope, then rises with a steeper slope, then levels off horizontally, and finally falls with a steep slope back to the horizontal axis.

**A.** Tom took his dog for a walk to the park. He set off slowly and then increased his pace. At the park Tom turned around and walked slowly back home.

**B.** Tom rode his bike east from his home up a steep hill. After a while the slope eased off. At the top he raced down the other side.

**C.** Tom went for a jog. At the end of his road he bumped into a friend and his pace slowed. When Tom left his friend he walked quickly back home.

Ask students to match the correct story to the graph. They are to write down at least two reasons to support their decision.

After two or three minutes ask students who selected option A to raise their hands. Ask one or two to justify their choice. You may wish to use some of the questions on the sheet *Suggested questions and prompts* to encourage students to justify their choices and others to challenge their reasoning.

Repeat this with options B and C. Even if explanations are incorrect or only partially correct, write them next to the appropriate section of the graph. Encourage students to challenge these interpretations.

Slide P-2 of the projector resource allows you to write three different student explanations on the board at the same time.



A graph may end up looking like this:

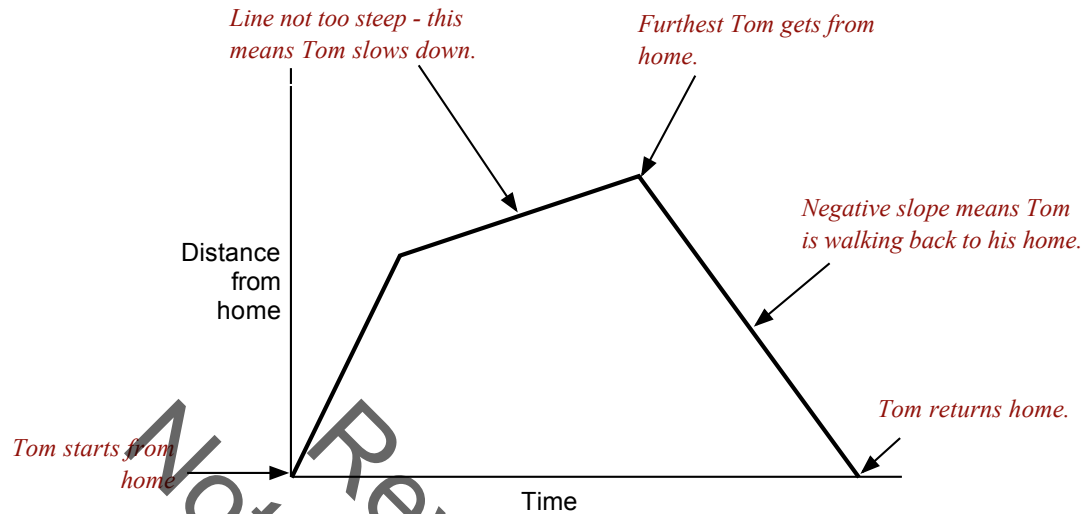

This is how students should annotate their graphs when working on the collaborative task.

**Collaborative activity: matching Card sets A and B (20 minutes)**

Ask students to work in small groups of two or three students.

Give each group the *Card Set A: Distance-Time Graphs*, and *Card Set B: Interpretations* together with a large sheet of paper, and a glue stick for making a poster.

*You are now going to continue exploring matching graphs with a story, but as a group.*

*You will be given ten graph cards and ten story cards.*

*In your group take a graph and find a story that matches it. Alternatively, you may want to take a story and find a graph that matches it.*

*Take turns at matching pairs of cards. Each time you do this, explain your thinking clearly and carefully. If you think there is no suitable card that matches, write one of your own.*

*Place your cards side by side on your large sheet of paper, not on top of one another, so that everyone can see them.*

*Write your reasons for the match on the cards or the poster just as we did with the example in class. Give explanations for each line segment.*

*Make sure you leave plenty of space around the cards as, eventually, you will be adding another card to each matched pair.*

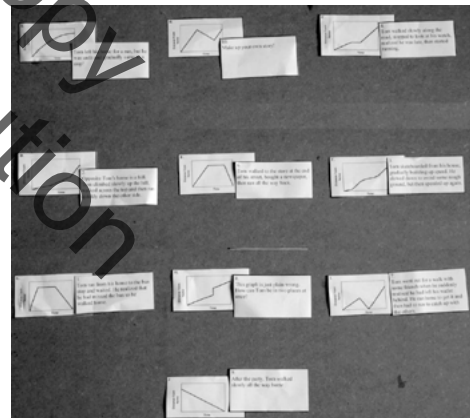

The purpose of this structured group work is to encourage students to engage with each other's explanations and take responsibility for each other's understanding.

Slide P-3 of the projector resource summarizes these instructions.

You have two tasks during the small-group work: to make a note of student approaches to the task, and to support student reasoning.

### Make a note of student approaches to the task

Listen and watch students carefully. Note different student approaches to the task and any common mistakes. For example, students may interpret the graph as a picture or students may read the graph from right to left. Also notice the ways students check to see if their match is correct and how they explain and justify a match to each other. You can use this information to focus a whole-class discussion.

### Support student reasoning

Try not to make suggestions that move students towards a particular match. Instead, ask questions to help students to reason together. If you find one student has produced a solution for a particular match, challenge another student in the group to provide an explanation.

*John matched these cards. Sharon, why do you think John matched these two cards?*

If you find students have difficulty articulating their decisions, then use the sheet *Suggested questions and prompts* to support your own questioning of students.

In trials of this lesson some students had difficulty stating where home is on the graph.

*For this graph, where does the journey start? Is that home?*

*Give me a graph that shows a journey starting away from home.*

*For this graph, does the journey end at home? How do you know?*

If the whole class is struggling on the same issue, you could write a couple of questions on the board and hold an interim, whole-class discussion. You could ask students who performed well in the assessment to help struggling students.

Some of the cards are deliberate distracters. For example, a student who matches Card 2 and E indicates that they think that graphs are pictures of the situation.

2 Opposite Tom's home is a hill. Tom climbed slowly up the hill, walked across the top, and then ran quickly down the other side.

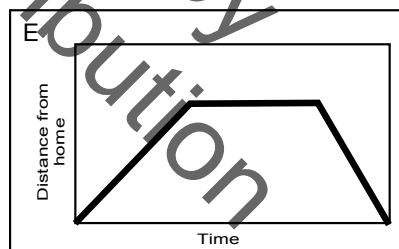

Allow students time to match all the cards they can.

### Sharing posters (10 minutes)

As students finish matching the cards, ask one student from each group to visit another group's poster.

You may want to use Slide P-4 of the projector resource to display the following instructions.

*If you are staying at your desk, be ready to explain the reasons for your group's matches.*

*If you are visiting another group, write your card placements on a piece of paper. Go to another group's desk and check to see which matches are different from your own.*

*If there are differences, ask for an explanation. If you still don't agree, explain your own thinking.*

*When you return to your own desk, you need to consider as a group whether to make any changes to your own poster.*

Students may now want to make changes to their poster. At this stage there is no need for students to glue the cards onto their posters as they may decide to make further changes.

**If you need to extend the lesson over two days:**

Once students have finished sharing posters, organize a whole-class discussion. Invite pairs of students to describe one pair of cards that they think they have matched correctly and the reasoning they employed. Encourage other students to challenge their explanations.

Finally, ask students to note their matches on the back of their poster and to use a paperclip to attach all cards to the poster.

At the start of the second lesson, spend a few minutes reminding the class about the activity:

*Can you remember what we were working on in the last lesson?*

Return the posters to each group. The whole-class discussion on interpreting tables can serve as an introduction to the lesson.

**Whole-class discussion: Interpreting tables (15 minutes)**

Bring the class together and give each student a mini-whiteboard, a pen, and an eraser. Display Slide P-5 of the projector resource:

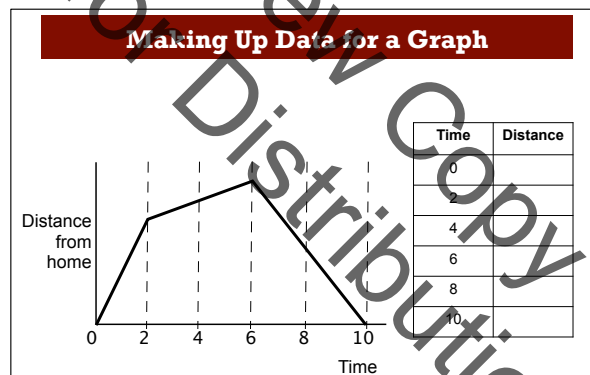

*On your whiteboard, create a table that shows possible times and distances for Tom's journey.*

After a few minutes, ask students to show you their whiteboards. Ask some students to explain how they created their tables. Write their figures on the board. Ask the rest of the class to check these figures.

*Is Tom's speed slower or faster in this section compared to that section?*

*How do you know from the graph? From the table?*

*Is this speed constant? How can you tell? Do the figures in the table show a constant speed for this section of the journey?*

*What units might these be measured in?*

*Are these figures realistic?*

**Collaborative activity: matching Card Set C (20 minutes)**

Hand out *Card Set C: Tables of Data* and ask students to match these cards with the cards already on their poster.

*You are now going to match tables with the cards already on your desk. In your group take a graph and try to find a table that matches it, or take a table and find a graph that matches it.*

*Again take turns at matching cards you think belong together. Each time you do this, explain your thinking clearly and carefully.*

*Write your reasons for the match on the poster.*

Students may also wish to suggest suitable units for the distances and times on the cards.

The tables should help students confirm or modify existing matches.

As they work on the matching, support the students as in the previous matching activity.

In the past, some students have had difficulty understanding the repetition in Table R. The table is intended to show the impossibility of Graph H.

R

Time	Distance
0	0
1	18
2	36
3	54
3	84
5	120

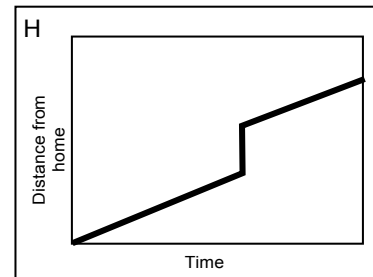

Some teachers have found that it helps students to look at the average speeds between consecutive times, by calculating differences. For example, average speeds for Table of Data Q would look like this.

Q

Time	Distance
0	0
1	10
2	20
3	40
4	60
5	120

*Average speed*  
 10  
 10  
 20  
 20  
 60

This may help students to understand that the table on Card Q matches Tom's hill walk, and that the correct distance-time graph should therefore be Card D.

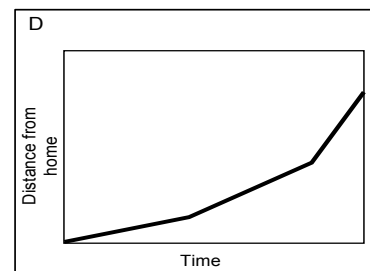

If some students finish quickly, encourage them to devise their own pairs of cards.

**Sharing posters (10 minutes)**

When students have completed the task, the student who has not already visited another pair should share their work with another pair of students. Students are to share their reasoning as they did earlier in the lesson unit.

Students may now want to make final changes to their poster. When they are completely satisfied, ask them to glue their cards onto the large sheet of paper.

**Whole-class discussion (10 minutes)**

Using mini-whiteboards, make up some journeys and ask the class to show you the corresponding graphs.

*On your whiteboards, draw a distance–time graph to show each of the following stories:*

- *Sam ran out of his front door, then slipped and fell. He got up and walked the rest of the way to school.*
- *Sara walked from home up the steep hill opposite her house. She stopped at the top to put her skates on, then skated quickly down the hill, back home again.*
- *Chris cycled rapidly down the hill that starts at his house. He then slowed down as he climbed up the other side.*

Ask students to show their whiteboards to the whole-class. Select some to explain their graph to the class. Encourage others in the class to challenge their reasoning.

**Follow-up lesson: Reviewing the assessment task (15 minutes)**

Return the original assessment *Journey to the Bus Stop* to the students together with a copy of *Journey Home*.

If you have not added questions to individual pieces of work, or highlighted questions on a printed list of questions, then write your list of questions on the board. Students should select only the questions from this list they think are appropriate to their own work.

*Look at your original responses and the questions (on the board written on your script.)*

*Use what you have learned to answer these questions.*

*Now look at the new task sheet, Journey Home.*

*Use what you have learned to answer these questions.*

If you are short of time, then you could set this task as homework.

## SOLUTIONS

### Assessment task: Journey to the Bus Stop

- The straight lines indicate that Tom moves at a constant but different speed in each section. Tom walks a total of 280 yards ( $100 + 60 + 120$ ). He is walking for 100 seconds. The graph shows Tom's journey is split into four sections.

**A** In this section of the journey Tom walks away from home at a speed of 2 meters per second ( $100 \div 50$ ) for 50 seconds.

**B** The negative slope here means a change in direction. At 100 meters from home Tom starts to walk towards home. He walks for 60 meters at a speed of 3 meters per second ( $60 \div 20$ ).

**C** At the start of this section Tom changes direction. He is now walking away from home at a fast pace. His speed is 4 meters per second ( $120 \div 30$ ). He moves at this speed for 30 seconds and covers 120 meters.

**D** Here the slope is zero. This means at 160 meters from home Tom stops. It has taken him 100 seconds to get to this point.

- The speeds provided in the answer to question 1 are realistic. A speed of 2 meters per second is a brisk walk. A speed of 4 meters per second means Tom is running.

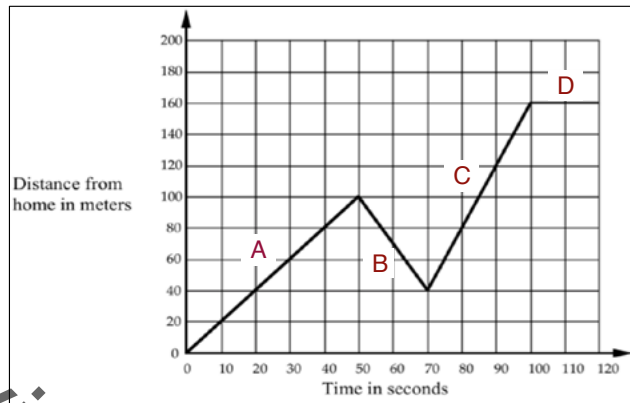

### Post Assessment task: Journey Home

- The straight lines indicate that Sylvia moves at a constant but different speed in each section. The overall journey takes 90 minutes and Sylvia bikes a total of 10 miles ( $2 + 1 + 7$ ). The graph shows Sylvia's journey is split into four sections.

**A** In this section of the journey Sylvia bikes towards home at a speed of 4 miles per hour ( $2 \div 0.5$ ) for 30 minutes.

**B** Here the slope is zero. Six miles from home Sylvia has stopped for 20 minutes.

**C** The positive slope here means a change in direction. After 50 minutes Sylvia bikes away from home for 1 mile. She bikes at a speed of 6 miles per hour ( $1 \div 10/60$ ).

**D** In this section Sylvia spends 30 minutes biking 7 miles home. Her speed is 14 miles per hour ( $7 \div 1/2$ ).

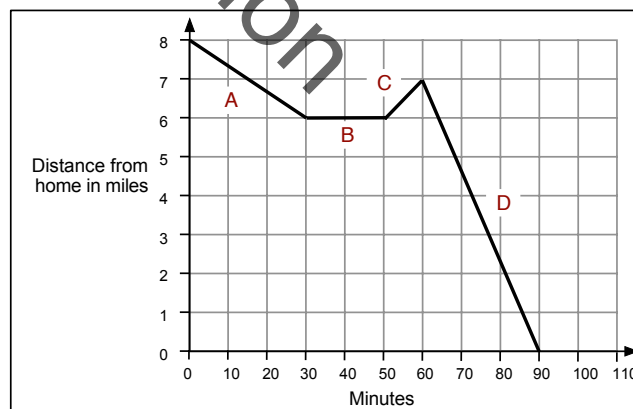

2. Although unrealistic for anyone to bike at a constant speed the average speeds for each section are realistic, although for the first 60 minutes Sylvia is not biking very fast. Maybe the wind was against her!

**Collaborative activity**

Graph	Interpretation	Table	Graph	Interpretation	Table
A	5	W	B	10	S
C	4	V	D	2	Q
E	6	T	F	3	
G	1	P	H	8	R
I	7	U	J	9	X

**Graph A:** Distance from home vs Time. Scenario 5: Tom left his home for a run but he was unfit and gradually came to a stop.

Time	Distance
0	0
1	44
2	85
3	105
4	120
5	125

**Graph B:** Distance from home vs Time. Scenario 10: Make up your own story!

Time	Distance
0	0
1	49
2	89
3	89
4	49
5	89

**Graph C:** Distance from home vs Time. Scenario 4: Tom walked slowly along the road, stopped to look at his watch, realized he was late, and then started running.

Time	Distance
0	0
1	25
2	45
3	45
4	85
5	120

**Graph D:** Distance from home vs Time. Scenario 2: Opposite Tom's home is a hill. Tom climbed slowly up the hill, walked across the top, and then ran quickly down the other side.

Time	Distance
0	0
1	10
2	20
3	40
4	60
5	120

**Graph E:** Distance from home vs Time. Scenario 6: Tom walked to the end of his street, bought a newspaper, and then ran all the way back.

Time	Distance
0	0
1	25
2	45
3	45
4	45
5	0

**Graph F:** Distance from home vs Time. Scenario 3: Tom was exhausted from school, gradually building speed, he slowed down to rest on the ground, but picked up again.

Time	Distance
0	0
1	10
2	20
3	40
4	40
5	80
6	100
7	100
8	100
9	120

**Graph G:** Distance from home vs Time. Scenario 1: Tom ran from his home to stop and waited. He realized he had missed the bus so he walked home.

Time	Distance
0	0
1	40
2	40
3	40
4	20
5	0

**Graph H:** Distance from home vs Time. Scenario 8: This graph is just plain weird. How can Tom be in two places at once?

Time	Distance
0	0
1	18
2	35
3	24
4	84
5	122

**Graph I:** Distance from home vs Time. Scenario 7: Tom went out for a walk. He suddenly realized he had left his wallet behind. He ran home to get it and then had to run to catch up with the others.

Time	Distance
0	0
1	30
2	60
3	60
4	80
5	120

**Graph J:** Distance from home vs Time. Scenario 9: After the party, Tom walked all the way home.

Time	Distance
0	120
1	86
2	72
3	48
4	24
5	0

## Journey to the Bus Stop

Every morning Tom walks along a straight road from his home to a bus stop, a distance of 160 meters. The graph shows his journey on one particular day.

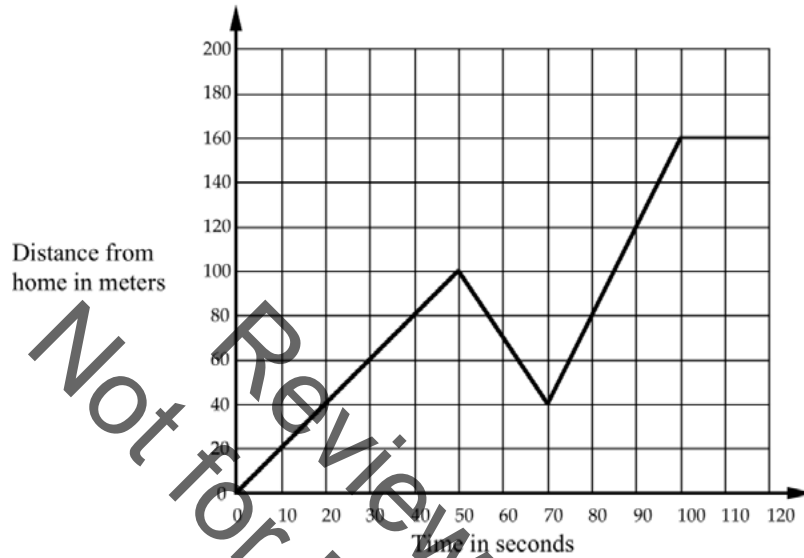

1. Describe what may have happened. You should include details like how fast he walked.

.....

.....

.....

.....

.....

.....

.....

2. Are all sections of the graph realistic? Fully explain your answer.

.....

.....

.....

.....



### Card Set A: Distance–Time Graphs

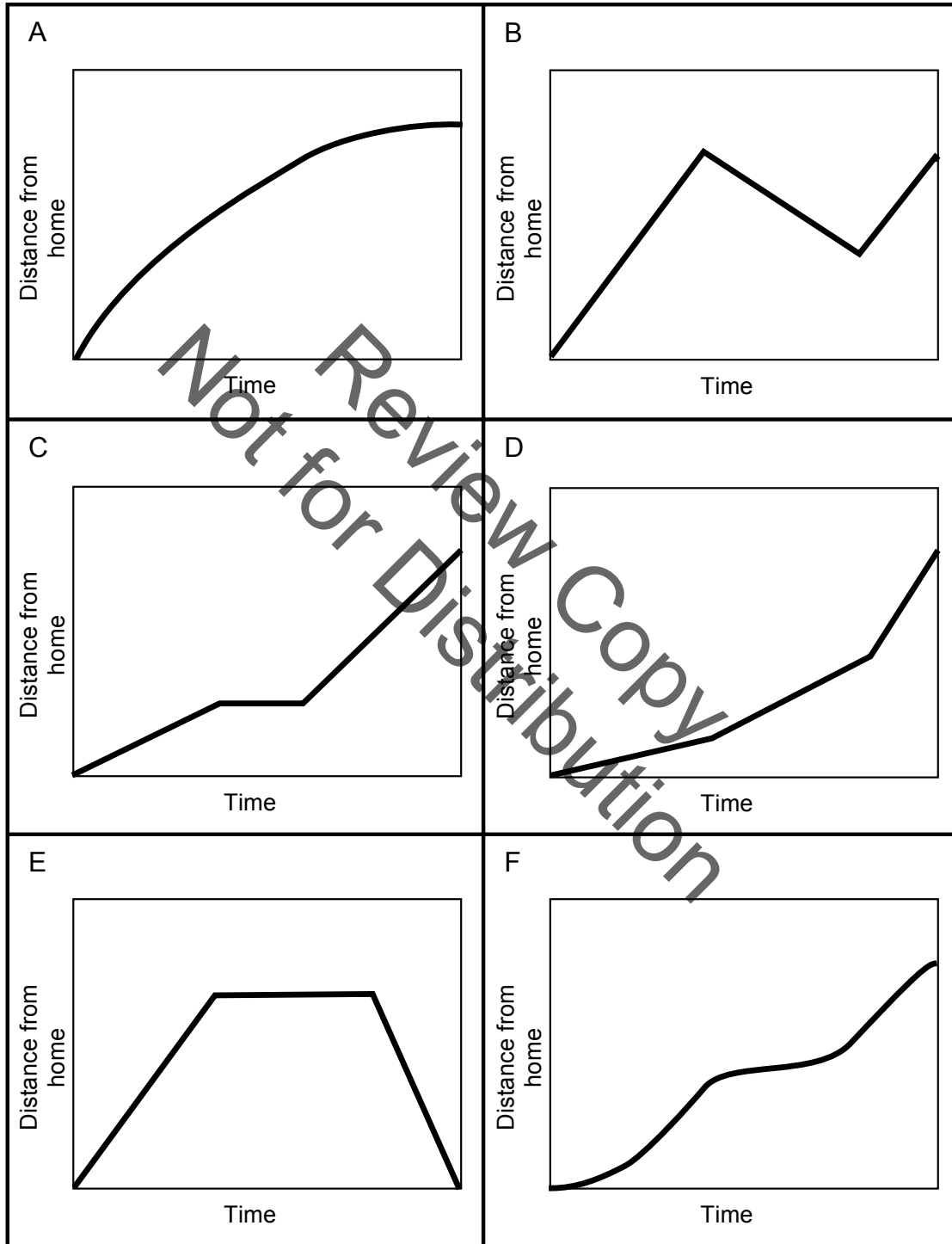

### Card Set A: Distance–Time Graphs (continued)

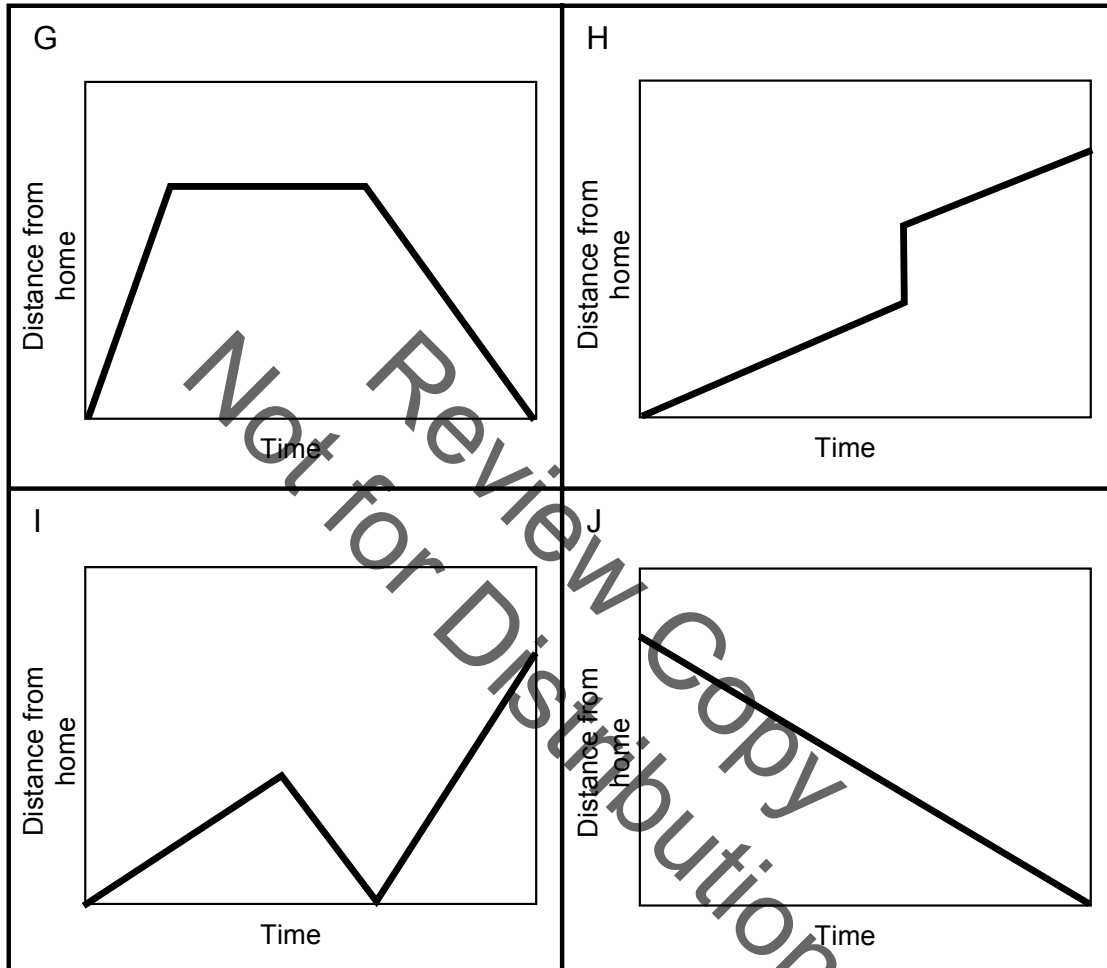

## Card Set B: Interpretations

<p><b>1</b> Tom ran from his home to the bus stop and waited. He realized that he had missed the bus so he walked home.</p>	<p><b>2</b> Opposite Tom's home is a hill. Tom climbed slowly up the hill, walked across the top, and then ran quickly down the other side.</p>
<p><b>3</b> Tom skateboarded from his house, gradually building up speed. He slowed down to avoid some rough ground, but then speeded up again.</p>	<p><b>4</b> Tom walked slowly along the road, stopped to look at his watch, realized he was late, and then started running.</p>
<p><b>5</b> Tom left his home for a run, but he was unfit and gradually came to a stop!</p>	<p><b>6</b> Tom walked to the store at the end of his street, bought a newspaper, and then ran all the way back.</p>
<p><b>7</b> Tom went out for a walk with some friends. He suddenly realized he had left his wallet behind. He ran home to get it and then had to run to catch up with the others.</p>	<p><b>8</b> This graph is just plain wrong. How can Tom be in two places at once?</p>
<p><b>9</b> After the party, Tom walked slowly all the way home.</p>	<p><b>10</b> Make up your own story!</p>

### Card Set C: Tables of Data

<b>P</b> <table border="1"> <thead> <tr><th>Time</th><th>Distance</th></tr> </thead> <tbody> <tr><td>0</td><td>0</td></tr> <tr><td>1</td><td>40</td></tr> <tr><td>2</td><td>40</td></tr> <tr><td>3</td><td>40</td></tr> <tr><td>4</td><td>20</td></tr> <tr><td>5</td><td>0</td></tr> </tbody> </table>	Time	Distance	0	0	1	40	2	40	3	40	4	20	5	0	<b>Q</b> <table border="1"> <thead> <tr><th>Time</th><th>Distance</th></tr> </thead> <tbody> <tr><td>0</td><td>0</td></tr> <tr><td>1</td><td>10</td></tr> <tr><td>2</td><td>20</td></tr> <tr><td>3</td><td>40</td></tr> <tr><td>4</td><td>60</td></tr> <tr><td>5</td><td>120</td></tr> </tbody> </table>	Time	Distance	0	0	1	10	2	20	3	40	4	60	5	120	<b>R</b> <table border="1"> <thead> <tr><th>Time</th><th>Distance</th></tr> </thead> <tbody> <tr><td>0</td><td>0</td></tr> <tr><td>1</td><td>18</td></tr> <tr><td>2</td><td>36</td></tr> <tr><td>3</td><td>54</td></tr> <tr><td>3</td><td>84</td></tr> <tr><td>5</td><td>120</td></tr> </tbody> </table>	Time	Distance	0	0	1	18	2	36	3	54	3	84	5	120						
Time	Distance																																																	
0	0																																																	
1	40																																																	
2	40																																																	
3	40																																																	
4	20																																																	
5	0																																																	
Time	Distance																																																	
0	0																																																	
1	10																																																	
2	20																																																	
3	40																																																	
4	60																																																	
5	120																																																	
Time	Distance																																																	
0	0																																																	
1	18																																																	
2	36																																																	
3	54																																																	
3	84																																																	
5	120																																																	
<b>S</b> <table border="1"> <thead> <tr><th>Time</th><th>Distance</th></tr> </thead> <tbody> <tr><td>0</td><td>0</td></tr> <tr><td>1</td><td>40</td></tr> <tr><td>2</td><td>80</td></tr> <tr><td>3</td><td>60</td></tr> <tr><td>4</td><td>40</td></tr> <tr><td>5</td><td>80</td></tr> </tbody> </table>	Time	Distance	0	0	1	40	2	80	3	60	4	40	5	80	<b>T</b> <table border="1"> <thead> <tr><th>Time</th><th>Distance</th></tr> </thead> <tbody> <tr><td>0</td><td>0</td></tr> <tr><td>1</td><td>20</td></tr> <tr><td>2</td><td>40</td></tr> <tr><td>3</td><td>40</td></tr> <tr><td>4</td><td>40</td></tr> <tr><td>5</td><td>0</td></tr> </tbody> </table>	Time	Distance	0	0	1	20	2	40	3	40	4	40	5	0	<b>U</b> <table border="1"> <thead> <tr><th>Time</th><th>Distance</th></tr> </thead> <tbody> <tr><td>0</td><td>0</td></tr> <tr><td>1</td><td>30</td></tr> <tr><td>2</td><td>60</td></tr> <tr><td>3</td><td>0</td></tr> <tr><td>4</td><td>60</td></tr> <tr><td>5</td><td>120</td></tr> </tbody> </table>	Time	Distance	0	0	1	30	2	60	3	0	4	60	5	120						
Time	Distance																																																	
0	0																																																	
1	40																																																	
2	80																																																	
3	60																																																	
4	40																																																	
5	80																																																	
Time	Distance																																																	
0	0																																																	
1	20																																																	
2	40																																																	
3	40																																																	
4	40																																																	
5	0																																																	
Time	Distance																																																	
0	0																																																	
1	30																																																	
2	60																																																	
3	0																																																	
4	60																																																	
5	120																																																	
<b>V</b> <table border="1"> <thead> <tr><th>Time</th><th>Distance</th></tr> </thead> <tbody> <tr><td>0</td><td>0</td></tr> <tr><td>1</td><td>20</td></tr> <tr><td>2</td><td>40</td></tr> <tr><td>3</td><td>40</td></tr> <tr><td>4</td><td>80</td></tr> <tr><td>5</td><td>120</td></tr> </tbody> </table>	Time	Distance	0	0	1	20	2	40	3	40	4	80	5	120	<b>W</b> <table border="1"> <thead> <tr><th>Time</th><th>Distance</th></tr> </thead> <tbody> <tr><td>0</td><td>0</td></tr> <tr><td>1</td><td>45</td></tr> <tr><td>2</td><td>80</td></tr> <tr><td>3</td><td>105</td></tr> <tr><td>4</td><td>120</td></tr> <tr><td>5</td><td>125</td></tr> </tbody> </table>	Time	Distance	0	0	1	45	2	80	3	105	4	120	5	125	<b>X</b> <table border="1"> <thead> <tr><th>Time</th><th>Distance</th></tr> </thead> <tbody> <tr><td>0</td><td>120</td></tr> <tr><td>1</td><td>96</td></tr> <tr><td>2</td><td>72</td></tr> <tr><td>3</td><td>48</td></tr> <tr><td>4</td><td>24</td></tr> <tr><td>5</td><td>0</td></tr> </tbody> </table>	Time	Distance	0	120	1	96	2	72	3	48	4	24	5	0						
Time	Distance																																																	
0	0																																																	
1	20																																																	
2	40																																																	
3	40																																																	
4	80																																																	
5	120																																																	
Time	Distance																																																	
0	0																																																	
1	45																																																	
2	80																																																	
3	105																																																	
4	120																																																	
5	125																																																	
Time	Distance																																																	
0	120																																																	
1	96																																																	
2	72																																																	
3	48																																																	
4	24																																																	
5	0																																																	
<b>Y</b> <p>Make this one up!</p> <table border="1"> <thead> <tr><th>Time</th><th>Distance</th></tr> </thead> <tbody> <tr><td>0</td><td></td></tr> <tr><td>1</td><td></td></tr> <tr><td>2</td><td></td></tr> <tr><td>3</td><td></td></tr> <tr><td>4</td><td></td></tr> <tr><td>5</td><td></td></tr> <tr><td>6</td><td></td></tr> <tr><td>7</td><td></td></tr> <tr><td>8</td><td></td></tr> <tr><td>9</td><td></td></tr> <tr><td>10</td><td></td></tr> </tbody> </table>	Time	Distance	0		1		2		3		4		5		6		7		8		9		10		<b>Z</b> <p>Make this one up!</p> <table border="1"> <thead> <tr><th>Time</th><th>Distance</th></tr> </thead> <tbody> <tr><td>0</td><td></td></tr> <tr><td>1</td><td></td></tr> <tr><td>2</td><td></td></tr> <tr><td>3</td><td></td></tr> <tr><td>4</td><td></td></tr> <tr><td>5</td><td></td></tr> <tr><td>6</td><td></td></tr> <tr><td>7</td><td></td></tr> <tr><td>8</td><td></td></tr> <tr><td>9</td><td></td></tr> <tr><td>10</td><td></td></tr> </tbody> </table>	Time	Distance	0		1		2		3		4		5		6		7		8		9		10		
Time	Distance																																																	
0																																																		
1																																																		
2																																																		
3																																																		
4																																																		
5																																																		
6																																																		
7																																																		
8																																																		
9																																																		
10																																																		
Time	Distance																																																	
0																																																		
1																																																		
2																																																		
3																																																		
4																																																		
5																																																		
6																																																		
7																																																		
8																																																		
9																																																		
10																																																		

## Journey Home

Sylvia bikes home along a straight road from her friend's house, a distance of 8 miles. The graph shows her journey.

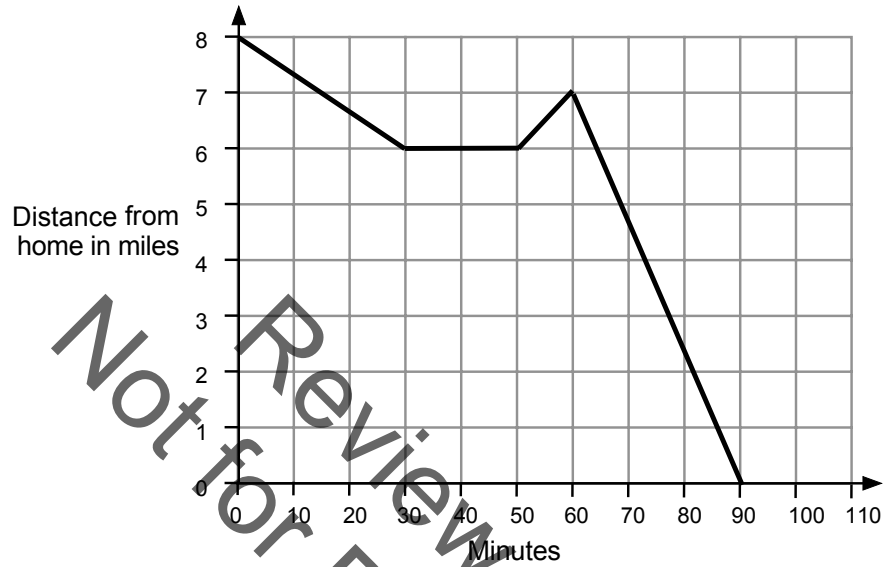

1. Describe what may have happened. You should include details like how fast she bikes.

.....

.....

.....

.....

.....

.....

.....

2. Are all sections of the graph realistic? Fully explain your answer.

.....

.....

.....

.....

# Matching a Graph to a Story

A. Tom took his dog for a walk to the park. He set off slowly and then increased his pace. At the park Tom turned around and walked slowly back home.

B. Tom rode his bike east from his home up a steep hill. After a while the slope eased off. At the top he raced down the other side.

C. Tom went for a jog. At the end of his road he bumped into a friend and his pace slowed. When Tom left his friend he walked quickly back home.

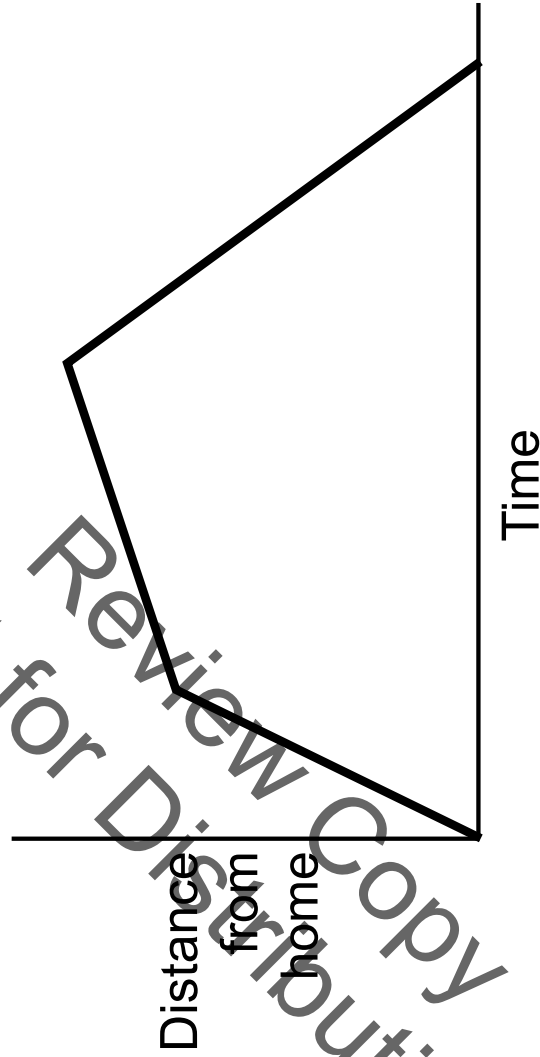

A. Tom took his dog for a walk to the park. He set off slowly and then increased his pace. At the park Tom turned around and walked slowly back home.

B. Tom rode his bike east from his home up a steep hill. After a while the slope eased off. At the top he raced down the other side.

C. Tom went for a jog. At the end of his road he bumped into a friend and his pace slowed. When Tom left his friend he walked quickly back home.

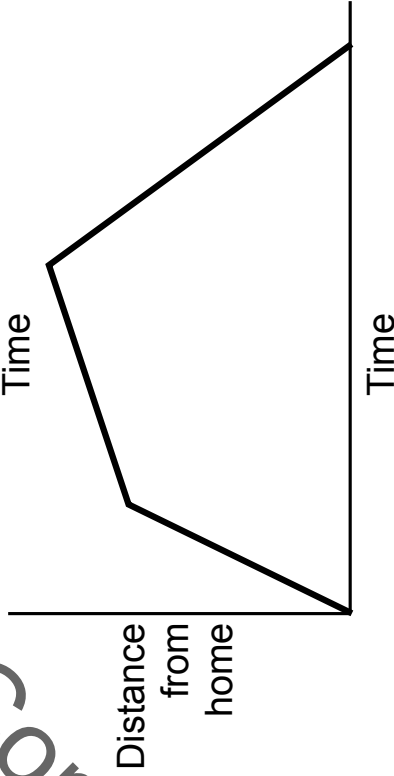
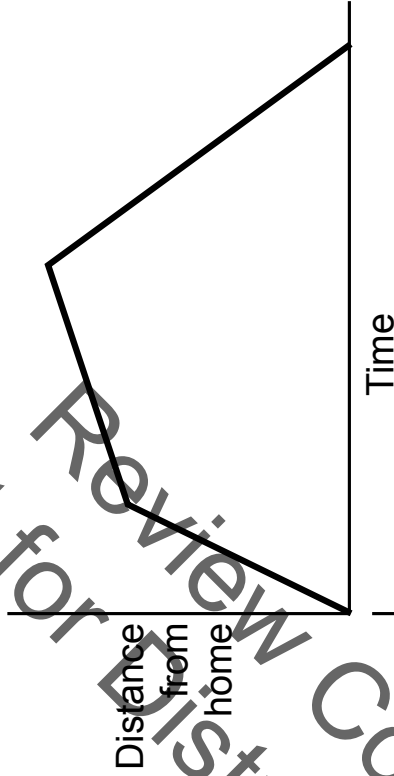
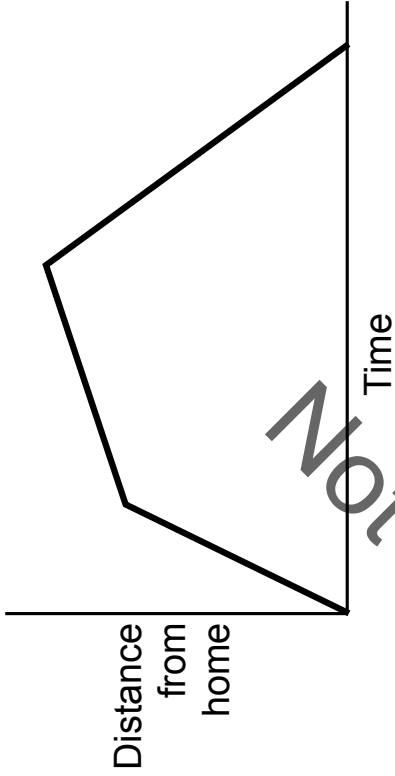

# Matching Cards

- Take turns at matching pairs of cards. You may want to take a graph and find a story that matches it. Alternatively, you may prefer to take a story and find a graph that matches it.
- Each time you do this, explain your thinking clearly and carefully. If you think there is no suitable card that matches, write one of your own.
- Place your cards side by side on your large sheet of paper, not on top of one another, so that everyone can see them.
- Write your reasons for the match on the cards or the poster just as we did with the example in class. Give explanations for each line segment.
- Make sure you leave plenty of space around the cards as, eventually, you will be adding another card to each matched pair.



## Sharing Work

- One student from each group is to visit another group's poster.
- If you are staying at your desk, be ready to explain the reasons for your group's matches.
- If you are visiting another group:
  - Write your card placements on a piece of paper.
  - Go to another group's desk and check to see which matches are different from your own.
  - If there are differences, ask for an explanation. If you still don't agree, explain your own thinking.
- When you return to your own desk, you need to consider as a group whether to make any changes to your own poster.

# Making Up Data for a Graph

Not for Review Copy  
Distribution

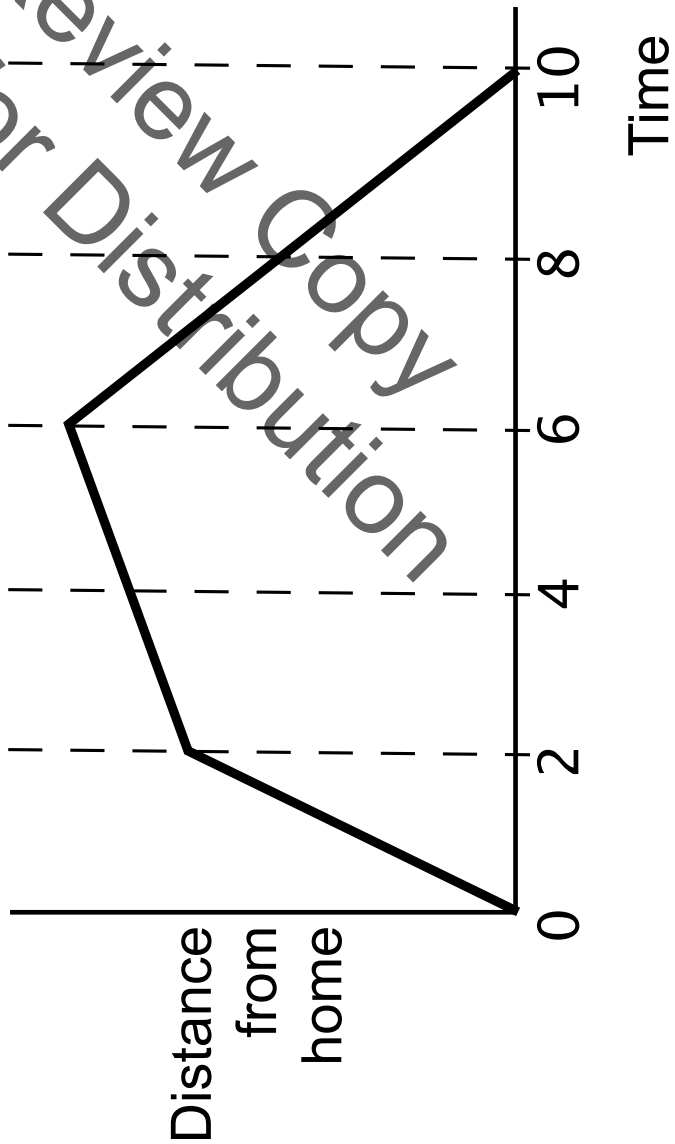

Time	Distance
0	
2	
4	
6	
8	
10	

## Mathematics Assessment Project **Classroom Challenges**

These materials were designed and developed by the  
Shell Center Team at the Center for Research in Mathematical Education  
University of Nottingham, England:

**Malcolm Swan,**  
**Nichola Clarke, Clare Dawson, Sheila Evans, Colin Foster, and Marie Joubert**  
with  
**Hugh Burkhardt, Rita Crust, Andy Noyes, and Daniel Pead**

We are grateful to the many teachers and students, in the UK and the US,  
who took part in the classroom trials that played a critical role in developing these materials

The classroom observation teams in the US were led by  
**David Foster, Mary Bouck, and Diane Schaefer**

This project was conceived and directed for  
The Mathematics Assessment Resource Service (MARS) by  
**Alan Schoenfeld** at the University of California, Berkeley, and  
**Hugh Burkhardt, Daniel Pead, and Malcolm Swan** at the University of Nottingham

Thanks also to Mat Crosier, Anne Floyde, Michael Galan, Judith Mills, Nick Orchard, and Alvaro Villanueva who contributed to the design and production of these materials

This development would not have been possible without the support of  
**Bill & Melinda Gates Foundation**

We are particularly grateful to  
**Carina Wong, Melissa Chabran, and Jamie McKee**

The full collection of Mathematics Assessment Project materials is available from

<http://map.mathshell.org>

© 2015 MARS, Shell Center, University of Nottingham  
This material may be reproduced and distributed, without modification, for non-commercial purposes,  
under the Creative Commons License detailed at <http://creativecommons.org/licenses/by-nc-nd/3.0/>  
All other rights reserved.

Please contact [map.info@mathshell.org](mailto:map.info@mathshell.org) if this license does not meet your needs.

## Functions and Linear Relationships

# Lesson 8 of 9

## A Model for Linear Data

### College- and Career-Readiness Standards Addressed:

---

Investigate patterns of association in bivariate data.

- SP.13 Construct and interpret scatter plots for bivariate measurement data to investigate patterns of association between two quantities. Describe patterns such as clustering, outliers, positive or negative association, linear association, and nonlinear association.
- SP.14 Know that straight lines are widely used to model relationships between two quantitative variables. For scatter plots that suggest a linear association, informally fit a straight line, and informally assess the model fit by judging the closeness of the data points to the line.
- SP.15 Use the equation of a linear model to solve problems in the context of bivariate measurement data, interpreting the slope and intercept. For example, in a linear model for a biology experiment, interpret a slope of 1.5 cm/hr as meaning that an additional hour of sunlight each day is associated with an additional 1.5 cm in mature plant height.

### Process Readiness Indicators:

---

- PRI 1: Make sense of problems and persevere in solving through reasoning and exploration.
  - PRI 4: Contextualize mathematical ideas by connecting them to real-world situations. Model with mathematics.
  - PRI 6: Attend to precision.
  - PRI 9: Demonstrate flexible use of strategies and methods while reflecting on which procedures seem to work best for specific types of problems.
- 
- Approximately one week before this lesson, pass out the Task #16: Student Temperature Data sheet and ask the students to begin collecting and recording temperature data at different times during the day and night in both degrees Celsius and Fahrenheit.
  - On the day of the lesson, the teacher should have copies of the Sample Temperature Data to provide to students who did not record their own data.
  - Although it is not advised, teachers can also opt to use the Sample Temperature Data and forgo the student collection of individual data.

Sequence of Instruction

Activities Checklist

Engage

PRI 1

Begin this lesson by projecting an online temperature converter tool. They are plentiful and easy to find with an internet search. Possible converter tools can be found here:

- <http://www.onlineconversion.com/temperature.htm>
- <http://fahrenheittocelsius.com/>

Explain to students that this tool will take a temperature in one measurement and convert it to the other.

In a new tab on your web browser, go to a website that will display the current temperature when given a location. Possible sites are as follows:

- <http://www.weather.com/>
- <http://www.weather.gov/>

Ask students to call out locations around the country and even the world. Type these locations into the weather website and record the current temperature in Fahrenheit on chart paper. Then, use the online converter tool to find that temperature in Celsius and record. Also explore the temperature of certain locations in the weather website in Celsius. On <http://www.weather.com/>, the units can be changed in the toolbar (see image below).

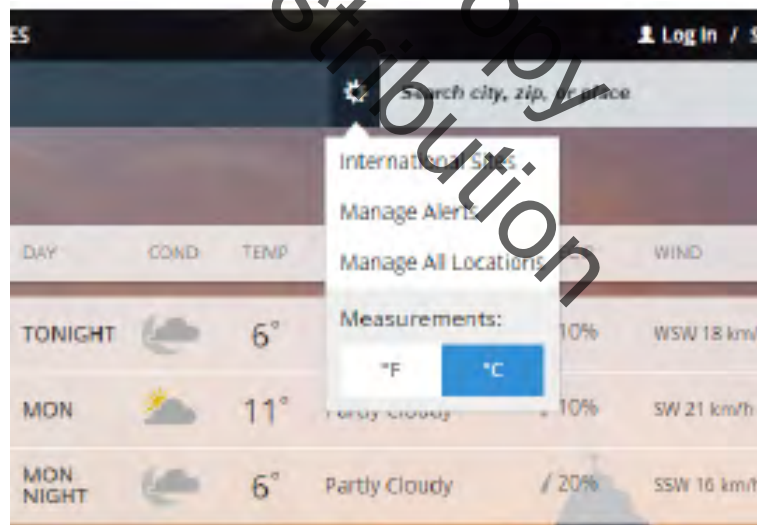

After you have gone through several examples and the students begin to understand the problem, start asking the students to predict what the converted temperature will be. Ask them to explain their mathematical reasoning behind their guesses and fully explore their conjectures on the relationship between Celsius and Fahrenheit temperatures. This may also be an appropriate time to mention that only a handful of countries use Fahrenheit to measure temperature. When traveling abroad, it is always a good idea to have a sense of the relationship between these two units.



**Note to teacher:** A common student misconception is mislabeling the independent and dependent axes. It is important here to point out that these variables could be represented on either axis because one unit of measure does not depend on the other. However, in many graphs there is one variable dependent on the other, and therefore assignment of the axes does matter. **To be consistent with the student activity, please make sure students are representing Celsius on the independent axis (horizontal) and Fahrenheit on the dependent axis (vertical).**

**Sample Temperature Data**

Temperatures in degrees Celsius and Fahrenheit were recorded at different times over a two week period. The data is shown in the table below.

°C	°F
7	44
11	51
5	41
16	60
20	68
22	71
18	65
15	59
12	54
9	48
6	43.5
17	63

Ask the students read and understand the problems and to answer the questions for Task #17: Analyzing the Temperature Graph from the Student Manual.

INCLUDED IN THE STUDENT MANUAL

**Task #17: Analyzing the Temperature Graph**

- Describe your graph. Could you connect some or many of the points in a familiar way? What would this look like?

---

- Do the points increase or decrease as you move from left to right across the horizontal axis?

---

- How could this graph be used to predict conversion values for temperatures that are not represented by points on your graph?

---

- Use your graph to estimate a conversion for the temperatures below.  
 $17^{\circ}\text{C} =$                        $30^{\circ}\text{C} =$                        $82^{\circ}\text{F} =$                        $0^{\circ}\text{F} =$

**Whole Group Discussion:** Engage the class in a discussion of their responses. Be sure to allow students to share their responses to #3 and make note of the different methods students might present.

**Analyzing the Temperature Graph** (possible solutions)

1. Describe your graph. Could you connect some or many of the points in a familiar way? What would this look like?

*Students should respond that the points on their graphs resemble a line.*

2. Do the points increase or decrease as you move from left to right across the horizontal axis?

*Students should respond that the points are increasing.*

3. How could this graph be used to predict conversion values for temperatures that are not represented by points on your graph?

*Answers will vary. Students may respond that they can estimate other values based on what is given in the graph, use points on the graph and find an average to estimate a point in between, or write an equation to model the relationship.*

## Explanation

---

Project the 5 minute video providing instruction on how to write a line of best fit from data found at:

[https://learnzillion.com/lesson\\_plans/6933-write-an-equation-for-line-of-best-fit](https://learnzillion.com/lesson_plans/6933-write-an-equation-for-line-of-best-fit).

**Note to teacher:** You will need to create a free account for access to instructional videos at [LearnZillion.com](https://learnzillion.com).

## Practice in Small Groups

---

**PRI 1**  
**PRI 4**  
**PRI 6**  
**PRI 9**

In small groups of 2-3, instruct students to complete the Task #18: Line of Best Fit and Linear Model. In this task, students will attend to precision as they draw a line of best fit, write a linear model for their temperature data, and use their equation to reason mathematically and make predictions within a real – world context.



INCLUDED IN THE STUDENT MANUAL

**Task #18: Line of Best Fit and Linear Model**

1. Use a ruler and draw a line of best fit that best represents the middle of your data and ignore any outlying data points.

2. Where does your line cross the vertical axis?

$$0^{\circ}\text{C} = \underline{\hspace{2cm}}^{\circ}\text{F}$$

3. Find two points and calculate the rate of change for your graph.

$$m = \frac{\text{difference } ^{\circ}\text{F}}{\text{difference } ^{\circ}\text{C}}$$

4. Use your answers from questions 2 and 3 to write a linear model for your data. Use slope-intercept form ( $y = mx + b$ ).

$$^{\circ}\text{F} = \underline{\hspace{2cm}}^{\circ}\text{C} + \underline{\hspace{2cm}}$$

5. Use your formula to convert the following temperatures.

$$17^{\circ}\text{C} = \underline{\hspace{2cm}} \quad 82^{\circ}\text{F} = \underline{\hspace{2cm}}$$

$$30^{\circ}\text{C} = \underline{\hspace{2cm}} \quad 0^{\circ}\text{F} = \underline{\hspace{2cm}}$$

6. Compare your estimations in question 4 of the *Analyzing the Temperature Graph* task to the answers you found in the question above.

After students have a linear model in #4, encourage them to check their equation with the graph to make sure it matches. This would be a good opportunity to incorporate the use of technology by asking students to first create a scatter plot of their temperature data using a graphing utility and then graph the equation from #4 to check for accuracy.

**Evaluate Understanding**

**PRI 1**  
**PRI 4**  
**PRI 9**

Ask students to share their responses to the questions in the Line of Best Fit and Linear Model task. Encourage students to share their mathematical reasoning and problem solving methods. Discuss similarities and differences and how placement of the line of best fit can alter their equations.

**TEACHER ANSWER KEY** Task #18 Line of Best Fit and Linear Model

1. Use a ruler and draw a line of best fit that best represents the middle of your data and ignore any outlying data points.

*Student answers will vary depending on temperature data collected.*

2. Where does your line cross the vertical axis?

$$0^{\circ}\text{C} = \underline{\hspace{2cm}}^{\circ}\text{F}$$

*Student answers will vary depending on temperature data collected but the value should be close to 32.*

3. Find two points and calculate the rate of change for your graph.

$$m = \frac{\text{difference } ^\circ F}{\text{difference } ^\circ C}$$

*Student answers will vary depending on temperature data collected and choice of points but the value should be comparable to  $\frac{9}{5}$ .*

4. Use your answers from questions 2 and 3 to write a linear model for your data. Use slope-intercept form ( $y = mx + b$ ).

$$^\circ F = \underline{\hspace{2cm}} C + \underline{\hspace{2cm}}$$

*Student answers will vary depending on answers from #2 and #3*

5. Use your formula to convert the following temperatures.

$$17^\circ C = \underline{\hspace{2cm}} \quad 82^\circ F = \underline{\hspace{2cm}}$$

$$30^\circ C = \underline{\hspace{2cm}} \quad 0^\circ F = \underline{\hspace{2cm}}$$

*Student answers will vary depending on equation from #4 but the actual temperature conversions are*

$$17^\circ C = 62.6^\circ F \quad 82^\circ F = 27.8^\circ C$$

$$30^\circ C = 86^\circ F \quad 0^\circ F = -17.8^\circ C$$

6. Compare your estimations in question 4 of the *Analyzing the Temperature Graph* task to the answers you found in the question above.

### Closing Activity

#### PRI 9

Students will complete the Task #19: Lesson 8 Exit Ticket where they will compare their equation from the Task #18: Line of Best Fit and Linear Model task to the actual equation for converting temperatures in degrees Celsius to Fahrenheit.

INCLUDED IN THE STUDENT MANUAL

#### Task #19: Lesson 8 Exit Ticket

The actual formula used in science to convert degrees Celsius to Fahrenheit is:

$$F = \frac{9}{5}C + 32$$

Write a paragraph comparing your equation from question 4 in the Line of Best Fit and Linear Model task to the formula above. Discuss any similarities or differences in the equations. What might cause the two equations to be slightly or even greatly different?

---



---



---



---



---



---



---



## Finding a Model for U.S. Population

# Lesson 9 of 9

## A Model for Linear Data

### College- and Career-Readiness Standards Addressed:

---

Investigate patterns of association in bivariate data.

- SP.13 Construct and interpret scatter plots for bivariate measurement data to investigate patterns of association between two quantities. Describe patterns such as clustering, outliers, positive or negative association, linear association, and nonlinear association.
- SP.14 Know that straight lines are widely used to model relationships between two quantitative variables. For scatter plots that suggest a linear association, informally fit a straight line, and informally assess the model fit by judging the closeness of the data points to the line.
- SP.15 Use the equation of a linear model to solve problems in the context of bivariate measurement data, interpreting the slope and intercept. For example, in a linear model for a biology experiment, interpret a slope of 1.5 cm/hr as meaning that an additional hour of sunlight each day is associated with an additional 1.5 cm in mature plant height.

### Process Readiness Indicators:

---

- PRI 1: Make sense of problems and persevere in solving through reasoning and exploration.
- PRI 3: Describe and justify mathematical understandings by constructing viable arguments, critiquing the reasoning of others and engaging in meaningful mathematical discourse.
- PRI 4: Contextualize mathematical ideas by connecting them to real-world situations. Model with mathematics.
- PRI 10: Reflect on mistakes and misconceptions to improve mathematical understanding.

Sequence of  
Instruction

Activities Checklist

### Engage

---

**Whole-Group Discussion:** Engage students in a discussion aimed at revisiting the unit hook. Remind them of the vocabulary and ideas that were presented at the beginning of the unit. Display the U.S. Population clock <http://www.census.gov/popclock/> but this time, allow students to see the rates underneath the clock.

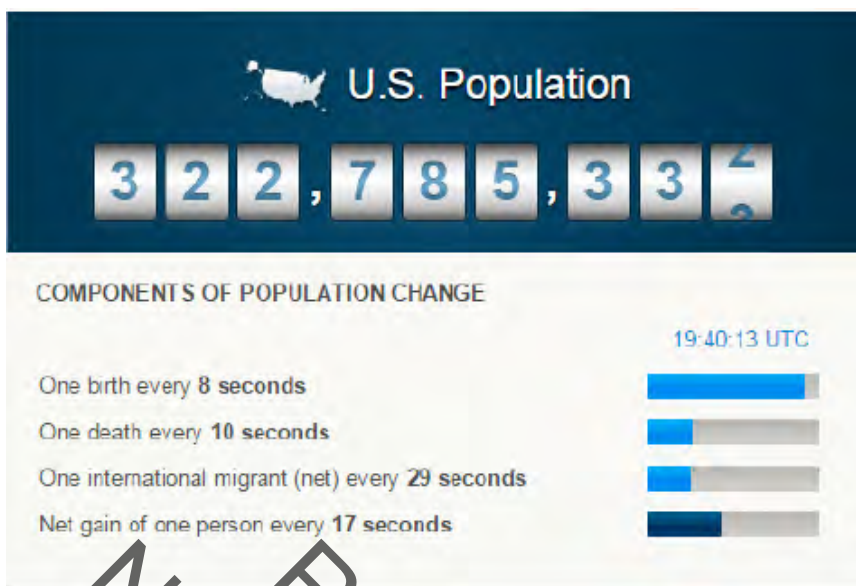

Possible discussion questions:

- Do you think these rates remain constant? If so, for how long?
- How might this clock be used?
- When do you believe the U.S. population will reach  $\frac{1}{2}$  billion people?

Share with students that in this culminating lesson, they will be examining and making models for population rates over time.

### Explore

**PRI 1**  
**PRI 4**

Instruct students to examine the table in Task #20: U.S. Population Part 1. Make sure students understand what it means for population to be measured “in thousands” before moving on. In this activity, students will persevere to analyze and answer questions relating real data for U.S. Population to mathematical models.

Ask students to work with a partner to complete Task #20: U.S. Population Part 1. Note that students need to see the U.S. Population clock online for “e” in the activity.

**INCLUDED IN THE STUDENT MANUAL**

#### Task #20: U.S. Population

**Part 1:** The table below provides some U.S. Population data from 1982 to 1988:

Year	Population (in thousands)	Change in Population (in thousands)
1982	231,664	....
1983	233,792	$233,792 - 231,664 = 2,128$
1984	235,825	2,033
1985	237,924	2,099
1986	240,133	2,209
1987	242,289	2,156
1988	244,499	2,210

- a. If we were to model the relationship between the U.S. population and the year, would a linear function be appropriate? Explain why or why not.

---

---

---

- b. Mike decides to use a linear function to model the relationship. He chooses 2,139, the average of the values in the 3rd column, for the slope. What meaning does this value have in the context of this model?

---

---

---

- c. Create an equation that Mike could have used to model the relationship between years since 1982 and population. Explain what the values in the equation mean in the context of this problem.

---

---

---

- d. Use Mike's model to predict the U.S. population in 1990. The actual population in 1990 was approximately 248,709,873. How well would Mike's model have predicted the actual population? Explain your mathematical thinking.

---

---

---

- e. How well will Mike's model predict the current U.S. population? Visit <http://www.census.gov/popclock/> to find the current U.S. population.

---

---

---

Not for Review Copy  
Distribution

Although there are different methods that can be used for creating the equation in “c”, students should notice that the independent variable represents the number of years since 1982 and therefore, the population in 1982 serves as the y-intercept.

## Explanation

PRI 3  
 PRI 10

**Whole-Group Discussion:** Ask students to share the equation created in “c” and the prediction made in “d”. Make sure all students arrive at the same, or close to, the same prediction for 1990 before moving on. Then, ask students to share Mike’s prediction for the current U.S. population. Students should see that although Mike’s equation fairly accurately predicted population for years close to 1988, the model does not do as well as the years get farther from the 1980’s. In the year 2015, for instance, the difference in the actual population and Mike’s predicted population differed by over 20 million people.

**TEACHER ANSWER KEY:** Task #20: U.S. Population

**Part 1:** The table below provides some U.S. Population data from 1982 to 1988:

Year	Population (in thousands)	Change in Population (in thousands)
1982	231,664	...
1983	233,792	$233,792 - 231,664 = 2,128$
1984	235,825	2,033
1985	237,924	2,099
1986	240,133	2,209
1987	242,289	2,156
1988	244,499	2,210

- a. If we were to model the relationship between the U.S. population and the year, would a linear function be appropriate? Explain why or why not.

*Yes, a linear function would be appropriate. Because the change in population from one year to the next is close to the same value, there is an approximate constant rate of change.*

- b. Mike decides to use a linear function to model the relationship. He chooses 2,139, the average of the values in the 3rd column, for the slope. What meaning does this value have in the context of this model?

*This value represents the approximate increase in population (in thousands) each year from 1982-1988.*

- c. Create an equation that Mike could have used to model the relationship between years since 1982 and population. Explain what the values in the equation mean in the context of this problem.

$$y = 231,664 + 2.139x$$

*231,664 represents the population of 231,664,000 in 1982 and 2,139 represents an increase in population each year of 2,139,000.*

- d. Use Mike's model to predict the U.S. population in 1990. The actual population in 1990 was approximately 248,709,873. How well would Mike's model have predicted the actual population? Explain your mathematical thinking.

*Mike's model predicted a population of 248,776,000 which is about 67,000 off from the actual population in 1990. Mike's model predicted the population in 1990 fairly well.*

- e. How well will Mike's model predict the current U.S. population? Visit <http://www.census.gov/popclock/> to find the current U.S. population.

*For the year 2016, Mike's model predicts a population of 304,390,000, however, the population in May of 2016 was 323,523,110. The difference here is significant with Mike's model predicting approximately 20 million fewer people than the actual.*

**Think-Pair-Share:** Why do you think the values between the actual and predicted population are so different? Students will share their mathematical reasoning and critique the reasoning of others. Students will have the opportunity to reflect on their misconceptions and improve their mathematical understanding through discussion.

**Note to teacher:** The question posed above is intended to allow students to share their ideas and for the teacher to learn from students' current understanding. It is not quite time yet to discuss the fact that a linear model may not be the best model for population unless students arrive at that idea on their own.

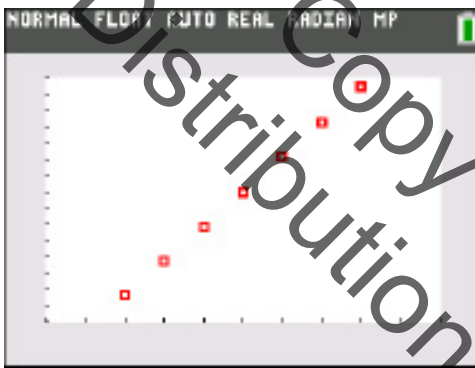

*This population data from 1982-1988 may be good to display for students throughout this discussion.*

### Practice with a Partner

---

Ask students to work again with a partner to complete Task #20: U.S. Population Part 2 where they will persevere to understand the problem and model the real — world problem graphically and algebraically.



INCLUDED IN THE STUDENT MANUAL

### Task #20: U.S. Population

**Part 2:** The table below provides some U.S. Population data from 1800 to 2010.

U.S. Population 1800-2010	
Year	Population (in thousands)
1800	5,308
1810	7,239
1820	9,638
1830	12,866
1840	17,069
1850	23,191
1860	31,443
1870	38,558
1880	50,189
1890	62,979
1900	76,212
1910	92,228
1920	106,021
1930	123,202
1940	132,164
1950	151,325
1960	179,323
1970	203,302
1980	226,542
1990	248,709
2000	281,421
2010	307,745
2020	
2030	
2040	
2050	
2060	
2070	
2080	

- Plot the data in the table on a coordinate grid (or using a graphing utility). You will need to leave additional room on both axes in order to make predictions.
- Use your graph to predict the population for the missing data in the table. Plot these points on the graph and record their values in the table. (To distinguish between the real data and your predictions, you may want to mark your new points using a different colored pencil or a symbol, such as a star.)
- We now want to see how well Mike's model fits the population data over a greater length of time. Because Mike's model considered years since 1982 and we are now looking at data from 1800, his original equation needs to be adjusted. We know that he used a slope of 2,139 (in thousands) and the population in 1982 was 213,664 (in thousands).

Use this slope and the point (1982, 213664) to rewrite Mike's equation for our graph. If you are using a graphing utility, graph your equation on top of your data to compare.

- How well does Mike's model fit the US population data from 1800-2010? How close does Mike's model come to your predicted values for 2020-2080?
- Using Mike's equation from c., predict the US population in the year 2080. How close is this value to your predicted value in the table? Is this what you expected?
- According to Mike's model in c., when will the U.S. population reach half-a-billion? (Remember, population is represented in thousands).

**It is highly recommended that students have access to a graphing utility for this part,** however, if this is not possible, then students should graph by hand and the teacher can display a graphing utility on the board. For those without access to the technology, students will need graph paper (preferably a whole sheet) and colored pencils. Students need to extend their domain to the year 2080 and their y-axis to an approximate population of 500,000 (in thousands) in order to make predictions in b.

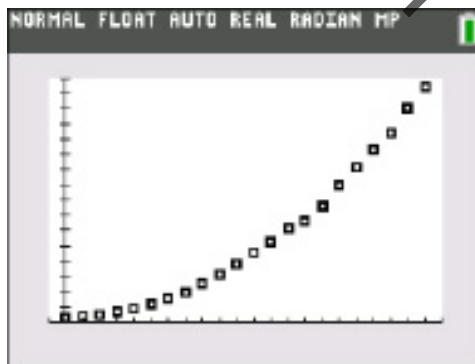

*U.S. Population 1800-2010*

For part c, students are adjusting Mike's original equation that used 1982 as the starting point. Now that we simply want to show Mike's equation passing through the point (1982, 213,664) with a slope of 2,139, students can use point-slope formula or slope-intercept form to write the equation. Students with a graphing utility should graph

this equation with the data (see figure below). However, this equation will be difficult to graph by hand given that the y-intercept falls far below the origin. The teacher should display the data and the equation so that all students can see their relationship.

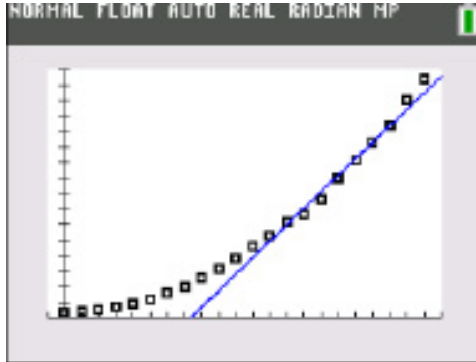

U.S. Population 1800-2010 with a domain (1800, 2010)  
and a range (5,000, 310,000)

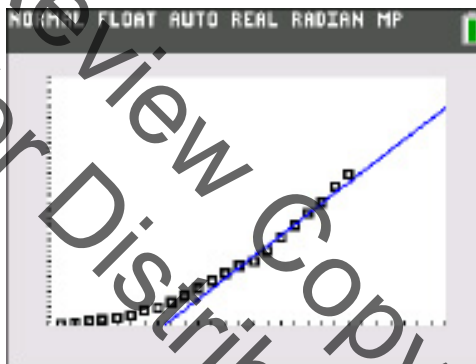

This is the same data with an extended domain and range.

**Whole-Group Discussion:** Engage students in a discussion focused specifically on d., e., and f. in this task. Use this time to also discuss any misconceptions you may have noticed during the work session to improve mathematical understanding.

**TEACHER ANSWER KEY:** Task #20: U.S. Population

**Part 1:** The table below provides some U.S. Population data from 1882 to 1988:

U.S. Population 1800-2010	
Year	Population (in thousands)
1800	5,308
1810	7,239
1820	9,638
1830	12,866
1840	17,069
1850	23,191
1860	31,443
1870	38,558
1880	50,189
1890	62,979
1900	76,212
1910	92,228
1920	106,021
1930	123,202
1940	132,164
1950	151,325
1960	179,323
1970	208,302
1980	226,542
1990	248,709
2000	281,421
2010	307,745
2020	
2030	
2040	
2050	
2060	
2070	
2080	

- a. Plot the data in the table on a coordinate grid (or using a graphing utility). You will need to leave additional room on both axes in order to make predictions.

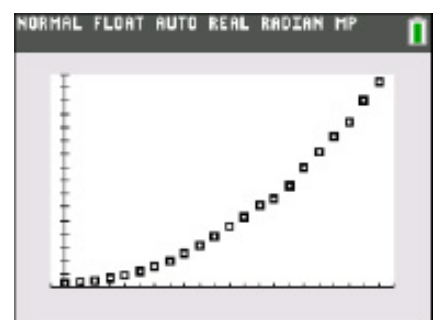

- b. Use your graph to predict the population for the missing data in the table. Plot these points on the graph and record their values in the table. (To distinguish between the real data and your predictions, you may want to mark your new points using a different colored pencil or a symbol, such as a star.)

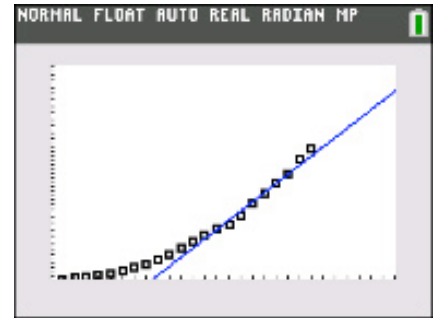

*Answers will vary but the points should continue to increase along the curve.*

- c. We now want to see how well Mike's model fits the population data over a greater length of time. Because Mike's model considered years since 1982 and we are now looking at data from 1800, his original equation needs to be adjusted. We know that he used a slope of 2,139 (in thousands) and the population in 1982 was 213,664 (in thousands).

Use this slope and the point (1982, 213664) to rewrite Mike's equation for our graph. If you are using a graphing utility, graph your equation on top of your data to compare.

$$y = 2,139x - 4,025,834$$

- d. How well does Mike's model fit the US population data from 1800-2010? How close does Mike's model come to your predicted values for 2020-2080?

*Mike's model appears to go through several points in the middle of the graph but the points begin to curve up and away from the line.*

*(Students will also need to compare their predictions for 2020-2080 to Mike's model. Answers will vary depending on their predictions but as the year move toward 2080, Mike's prediction should become farther from the predicted).*

- e. Using Mike's equation from c., predict the US population in the year 2080. How close is this value to your predicted value in the table? Is this what you expected?

*(Again, answers will vary depending on their predictions but as the year move toward 2080, Mike's prediction should become farther from the predicted).*

- f. According to Mike's model in c., when will the U.S. population reach half-a-billion? (Remember, population is represented in thousands).

*Using Mike's model, the population will reach half-a-billion in 2115.*

**Note to teacher:** Although students in this course would not have studied exponential and quadratic functions yet, it is important for them to know that not all functions are linear. As is the case with the population data, a linear model worked very well for the short time period between 1982 and 1988 but clearly did not do well at making predictions for later years. The graph below shows a quadratic model in blue and an exponential model in red. Share this graph with students and discuss different models that can be used to make predictions.

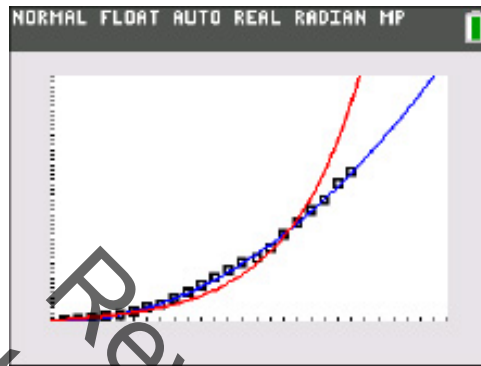

### Evaluate Understanding

**Think-Pair-Share:** To help students communicate their mathematical understanding of the problem, pose the following questions.

- How long do you believe the population will continue to grow at this rate?
- What factors might cause the population growth to slow?

Ask the students to justify their reasoning and critique the reasoning of their partner.

**Note to teacher:** This is a great opportunity to discuss a connection between mathematics and science. Although mathematicians love to make models that “match” a set of data, rarely does a model match a set of data indefinitely. At some point, Earth’s resources will not be able to sustain population growth at the rate we have examined. Eventually, the population growth rate will slow and the data will begin to flatten.

### Closing Activity

In addition to having a science connection, we can also connect this population data set to U.S. history.

Once again, display the population data using a graphing utility. Pose this question to students:

Are there any data points that seem to not follow the pattern? In other words, are there any data points that seem to be “off”?

After students identify the point shown above, ask if anyone has an idea why this point seems out of place? Discuss with students that this dip in population growth occurred as a result of WWII when over 400,000

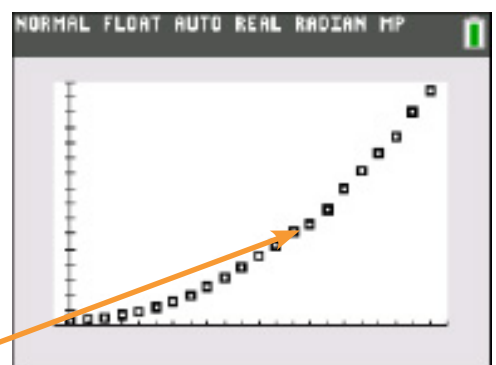



# SREB

## SREB Readiness Courses

# Ready for High School: Math

### Math Unit 7

### Systems of Equations

Not for Review Copy Distribution

Southern  
Regional  
Education  
Board

592 Tenth Street, NW  
Atlanta, GA 30318  
(404) 875-9211

[www.sreb.org](http://www.sreb.org)





## Unit 7 . Systems of Equations

### Overview

This unit aids students in understanding the solution to a system of equations is the point of intersection when the equations are graphed and that it contains the values that satisfies both equations. Students will be able to write and use a system of equations to solve a real-world problem.

### Essential Questions:

- *Why might the need to solve a linear system of equations arise in life?*
- *What tools can we use to solve a linear system of equations, and why might one be more useful than another?*
- *Why is the solution (when there is one unique solution) to a system of linear equations represented by the intersection of the graphs of the two lines?*
- *How many different types of solution sets are possible when solving a system of two linear equations?*

## College- and Career-Readiness Standards:

---

Understand the connections between proportional relationships, lines and linear equations.

- EE.12 Graph proportional relationships, interpreting the unit rate as the slope of the graph. Compare two different proportional relationships represented in different ways. *For example, compare a distance-time graph to a distance-time equation to determine which of two moving objects has greater speed.*

Analyze and solve linear equations and pairs of simultaneous linear equations.

- EE.15 Analyze and solve pairs of simultaneous linear equations.
  - a. Understand that solutions to a system of two linear equations in two variables correspond to points of intersection of their graphs, because points of intersection satisfy both equations simultaneously.
  - b. Solve systems of two linear equations in two variables algebraically, and estimate solutions by graphing the equations. Solve simple cases by inspection. For example,  $3x + 2y = 5$  and  $3x + 2y = 6$  have no solution because  $3x + 2y$  cannot simultaneously be 5 and 6.
  - c. Solve real-world and mathematical problems leading to two linear equations in two variables. For example, given coordinates for two pairs of points, determine whether the line through the first pair of points intersects the line through the second pair.

Use functions to model relationships between quantities.

- F.4. Construct a function to model a linear relationship between two quantities. Determine the rate of change and initial value of the function from a description of a relationship or from two  $(x, y)$  values, including reading these from a table or from a graph. Interpret the rate of change and initial value of a linear function in terms of the situation it models, and in terms of its graph or a table of values.

## Prior Scaffolding Knowledge / Skills:

---

Reason about and solve one-variable equations and inequalities.

- Use variables to represent numbers and write expressions when solving a real-world or mathematical problem; understand that a variable can represent an unknown number, or, depending on the purpose at hand, any number in a specified set.

Represent and analyze quantitative relationships between dependent and independent variables.

- Use variables to represent two quantities in a real-world problem that change in relationship to one another; write an equation to express one quantity, thought of as the dependent variable, in terms of the other quantity, thought of as the independent variable. Analyze the relationship between the dependent and independent variables using graphs and tables, and relate these to the equation. *For example, in a problem involving motion at constant speed, list and graph ordered pairs of distances and times, and write the equation  $d = 65t$  to represent the relationship between distance and time.*

Analyze and solve linear equations and pairs of simultaneous linear equations.

- Solve linear equations in one variable.

- a. Give examples of linear equations in one variable with one solution, infinitely many solutions, or no solutions. Show which of these possibilities is the case by successively transforming the given equation into simpler forms, until an equivalent equation of the form  $x = a$ ,  $a = a$ , or  $a = b$  results (where  $a$  and  $b$  are different numbers).
- b. Solve linear equations with rational number coefficients, including equations whose solutions require expanding expressions using the distributive property and collecting like terms.

### Lesson Progression Overview:

Lesson Big Idea	Lesson Details	Content Standards	Process Readiness Indicators
<b>Lesson 1:</b> <b>Entry Event:</b> <b>Playing Catch Up</b>	In this 3-Act Task, students explore using a system of equations to determine how long it would take Julio Jones to catch up to Rich Eisen in a 40-yard dash.	EE.12 EE.15	PRI 1 PRI 2 PRI 3 PRI 4 PRI 5 PRI 9
<b>Lesson 2:</b> <b>Representing and Graphing lines in Different Forms</b>	Students review graphing linear equations.	EE.5 EE.12 F.4	PRI 1 PRI 3 PRI 4 PRI 6 PRI 7
<b>Lesson 3:</b> <b>Solving Systems of Equations using Tables</b>	Students solve systems of equations using a tables of values.	EE.15	PRI 1 PRI 3 PRI 4 PRI 6 PRI 7
<b>Lesson 4:</b> <b>What is a solution when Solving Systems of Equations using Tables and Graphs?</b>	Students review what it means for a value to be a solution to an equation and explore the idea of a solution to a system of equations.	EE.14 EE.15	PRI 1 PRI 3 PRI 4 PRI 6 PRI 7
<b>Lesson 5:</b> <b>Solving Systems of Equations by Graphing</b>	Students set up and solve systems by graphing and estimation.	EE.12 EE.15 F.4	PRI 1 PRI 2 PRI 3 PRI 4 PRI 6 PRI 7 PRI 9

Lesson Big Idea	Lesson Details	Content Standards	Process Readiness Indicators
<b>Lesson 6: Formative Assessment Lesson: Classifying Solutions to Systems of Equations</b>	This lesson is intended to help you assess how well students are able to classify solutions to a pair of linear equations by considering their graphical representations; use substitution to complete a table of values for a linear equation; identify a linear equation from a given table of values; and graph and solve linear equations.	EE.15 F.4	PRI 7
<b>Lesson 7: Solving Systems of Equations using Substitution</b>	Students solve systems of equations algebraically using the substitution method.	EE.12 EE.15	PRI 1 PRI 2 PRI 3 PRI 6
<b>Lesson 8: Solving Systems of Equations using Elimination</b>	Students solve systems of equations algebraically using the elimination method.	EE.15	PRI 1 PRI 3 PRI 4 PRI 6
<b>Lesson 9: Culminating Activity: Stacking Cups</b>	Students will determine how many cups it takes for the stacks of Styrofoam and plastic cups to be equal.	EE.12 EE.15	PRI 1 PRI 2 PRI 3 PRI 4 PRI 5 PRI 6 PRI 9 PRI 10

## Systems of Equations

# Lesson 1 of 9

## Systems of Linear Equations

### College- and Career-Readiness Standards Addressed:

---

Understand the connections between proportional relationships, lines and linear equations.

- EE.12 Graph proportional relationships, interpreting the unit rate as the slope of the graph. Compare two different proportional relationships represented in different ways. For example, compare a distance-time graph to a distance-time equation to determine which of two moving objects has greater speed.

Analyze and solve linear equations and pairs of simultaneous linear equations.

- EE.15 Analyze and solve pairs of simultaneous linear equations.
  - a. Understand that solutions to a system of two linear equations in two variables correspond to points of intersection of their graphs, because points of intersection satisfy both equations simultaneously.
  - b. Solve systems of two linear equations in two variables algebraically, and estimate solutions by graphing the equations. Solve simple cases by inspection. For example,  $3x + 2y = 5$  and  $3x + 2y = 6$  have no solution because  $3x + 2y$  cannot simultaneously be 5 and 6.
  - c. Solve real-world and mathematical problems leading to two linear equations in two variables. For example, given coordinates for two pairs of points, determine whether the line through the first pair of points intersects the line through the second pair.

### Mathematical Process Readiness Indicator(s) Emphasized:

---

- PRI 1: Make sense of problems and persevere in solving through reasoning and exploration.
- PRI 2: Reason abstractly and quantitatively by using multiple forms of representations to make sense of and understand mathematics.
- PRI 3: Describe and justify mathematical understandings by constructing viable arguments, critiquing the reasoning of others and engaging in meaningful mathematical discourse.
- PRI 4: Contextualize mathematical ideas by connecting them to real-world situations. Model with mathematics.
- PRI 5: Use appropriate tools strategically to support thinking and problem solving.
- PRI 9: Demonstrate flexible use of strategies and methods while reflecting on which procedures seem to work best for specific types of problems.

Sequence of Instruction

Activities Checklist

Engage

PRI 1

Ask the students if they are familiar with the National Football League. If so, ask them about their favorite teams and players.

Act One:

Explain to them that the task for the day is about Atlanta Falcons receiver Julio Jones running a 40-yard dash against Rich Eisen, an NFL Network journalist.

Show the first video from Dan Meyer titled *Playing Catch Up* found at <http://threeacts.mrmeyer.com/playingcatchup/>.

Ask “Who do you think will win?” Have students record their best guess on the form.

Ask students to consider the following questions:

INCLUDED IN THE STUDENT MANUAL

**Task #1: Playing Catch Up Act One**

What did/do you notice?

\_\_\_\_\_

\_\_\_\_\_

\_\_\_\_\_

\_\_\_\_\_

What questions come to your mind?

\_\_\_\_\_

\_\_\_\_\_

\_\_\_\_\_

\_\_\_\_\_

**Main Question:** Who will win the race — Julio Jones or Rich Eisen?

\_\_\_\_\_

\_\_\_\_\_

\_\_\_\_\_

\_\_\_\_\_

Estimate the result of the main question. Explain your estimate.

## Explore

Act Two:

After students have had time to think and record their guesses, ask them: What information would be useful to know here?

INCLUDED IN THE STUDENT MANUAL

### Task #1: Playing Catch Up Act Two

What information would you like to know or do you need to solve the MAIN question?

---

---

---

---

---

Record the given information (measurements, materials, etc...)

---

---

---

---

---

Use this area for your work, tables, calculations, sketches, and final solution.

Hopefully, students would want to know some statistics (i.e., what is a recorded time for each man in the 40-yard dash, etc.). Statistics on Julio Jones and Rich Eisen can be found at in the Act 2 section of Playing Catch Up found at <http://threeacts.mrmeyer.com/playingcatchup/>. Provide the students with these information files as they ask for it.

## Practice in Small Groups / Individually

**PRI 2**  
**PRI 3**  
**PRI 4**  
**PRI 5**

Arrange students in pairs.

Students should use the information provided and work together to determine who they think should win the race. Be sure to listen carefully and support student reasoning.

Be sure to provide any additional information requested by students.

## Explanation

**PRI 9**

Act Three:

Ask student pairs to share their answers and explain their methods for determining their solutions. Have the class critique the reasoning of others' arguments.

INCLUDED IN THE STUDENT MANUAL

### Task #1: Playing Catch Up Act Three

What was the result? Is this different from your original guess?

---

---

---

## Evaluate Understanding

Once students have had a chance to provide reasonable answers using the information provided, reveal the answer by showing the video found in Act 3 of Playing Catch Up found at <http://threeacts.mrmeyer.com/playingcatchup/>.

## Closing Activity

The Sequel (Whole group discussion):

INCLUDED IN THE STUDENT MANUAL

### Task #1: Playing Catch Up Act The Sequel

What kind of head start would have allowed Julio Jones to beat Rich Eisen?

---

---

---



### Resources/Instructional Materials Needed:

---

Task #1: Playing Catch Up

All videos and statistics can be found at <http://threeacts.mrmeyer.com/playingcatchup/>.

### Notes:

---

It is suggested to download the videos and use in a Prezi or Power Point presentation to prevent connection issues.

Review Copy  
Not for Distribution

## Systems of Equations

# Lesson 2 of 9

## Systems of Linear Equations

### College- and Career-Readiness Standards Addressed:

---

Represent and analyze quantitative relationships between dependent and independent variables.

- EE.5 Use variables to represent two quantities in a real-world problem that change in relationship to one another; write an equation to express one quantity, thought of as the dependent variable, in terms of the other quantity, thought of as the independent variable. Analyze the relationship between the dependent and independent variables using graphs and tables, and relate these to the equation. *For example, in a problem involving motion at constant speed, list and graph ordered pairs of distances and times, and write the equation  $d = 65t$  to represent the relationship between distance and time.*

Understand the connections between proportional relationships, lines and linear equations.

- EE.12 Graph proportional relationships, interpreting the unit rate as the slope of the graph. Compare two different proportional relationships represented in different ways. *For example, compare a distance-time graph to a distance-time equation to determine which of two moving objects has greater speed.*

Use functions to model relationships between quantities.

- F.4. Construct a function to model a linear relationship between two quantities. Determine the rate of change and initial value of the function from a description of a relationship or from two  $(x, y)$  values, including reading these from a table or from a graph. Interpret the rate of change and initial value of a linear function in terms of the situation it models, and in terms of its graph or a table of values.

### Mathematical Process Readiness Indicator(s) Emphasized:

---

- PRI 1: Make sense of problems and persevere in solving through reasoning and exploration.
- PRI 3: Describe and justify mathematical understandings by constructing viable arguments, critiquing the reasoning of others and engaging in meaningful mathematical discourse.
- PRI 4: Contextualize mathematical ideas by connecting them to real-world situations. Model with mathematics.
- PRI 6: Attend to precision.
- PRI 7: Look for and make use of patterns and structure.

Sequence of Instruction

Activities Checklist

Engage

PRI 1  
PRI 4

Ask students the following questions. Have them think, pair and share their thoughts.

- Do you have enough time to pass between your classes?
- What information could help us convince the Administration to lengthen the walk time?

Teacher should guide students towards presenting qualitative data and thus lead them into the Explore Activity.

Explore

PRI 1  
PRI 4

Students calculate their average walking pace and graph a line to represent the time it takes them to travel a certain distance. Students will need a stop watch to record their pace (meters per second).

**Teacher note:** The instructions are for meters per second; however, you may consider converting to feet per minute so that students have a better gauge of distance and time.

**Instructions for calculating walking pace:**

1. Place a piece of tape on the baseboard, next to the floor, to use as a starting point. (Make sure you have at least 10 meters of space without any obstructions.)
2. Using a meter stick mark of a path 10 meters in length.
3. Place another piece of tape on the baseboard to mark the end of your course.
4. Using the stopwatch, find the time it takes your lab partner(s) to walk the 10m course. Record this information on the data table. **Note: Walking speed should be normal, steady walking speed.**
5. Calculate the walking speed.
6. Repeat two more trials of your timings, and then average the three.
7. Switch positions and have your lab partner time your walking speed.
8. Continue until all lab partners have their own set of data recorded.

Have students create a data table similar to the one below:

Trial	Distance (m)	Time (sec)	Speed (m/s)
1			
2			
3			
Average			

Ask students to graph their data according to the following instructions:

1. On graph paper, create a graph using the lab data from your results.
2. Plot the average time versus the average distance as a point on your graph. Use the origin as the other point and connect them.

Formatively assess students' background knowledge on independent variables (average time) and dependent variables (average distance walked) by holding a review discussion.

Teacher should provide students with approximate distances from other classrooms in the school or let the students use a scale drawing/map to determine the distances. Teacher selects a few students, displays the graphs using a projector/document camera and holds a whole group discussion:

What does the x intercept represent? *Sample answer: starting time*

What does the y-intercept represent? *Sample answer: starting distance*

What does the steepness of the line represent? *Sample answer: speed or rate of change*

How many ordered pairs do we need to graph this line? *Sample answer: Two*

Who should make it to math class first? *Guide students' responses based on speeds and graphs*

Will any of the students bump into each other along the way? If so, when? *Guide student responses based on graphs*

## Explanation

**PRI 1**  
**PRI 4**

Teacher says: Graphs visually represent situations and can help us make decisions. When an equation is in standard form:  $Ax + By = C$ , it is easy to find two points on the graph (the x and y intercepts) and connect them using a straight line. When an equation is in slope intercept form,  $y = mx + b$  it is easy to identify the y-intercept and find additional point(s) using the slope.

Here are two examples to share with students:

### Example #1

A canoe rental service charges a \$20 transportation fee and \$30 dollars an hour to rent a canoe. Write and graph an equation representing the cost,  $y$ , of renting a canoe for  $x$  hours. What is the cost of renting the canoe for 6 hours?

$$y = 30x + 20$$

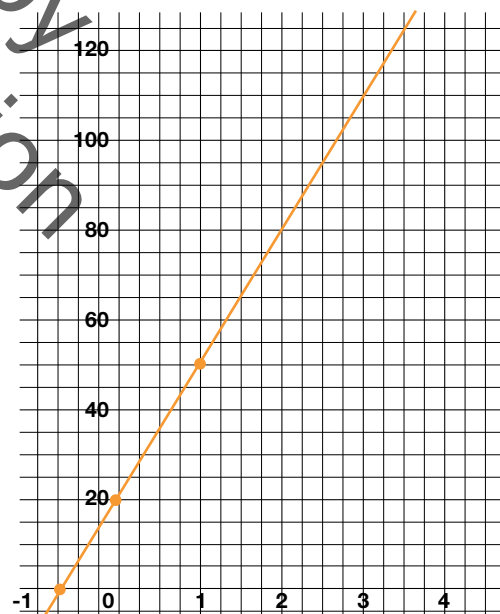

### Example #2

You are helping to plan an awards banquet for your school, and you need to rent tables to seat 180 people. Tables come in two sizes. Small tables seat 4 people and large tables seat 6 people. How many small tables are needed if there are 12 large tables?

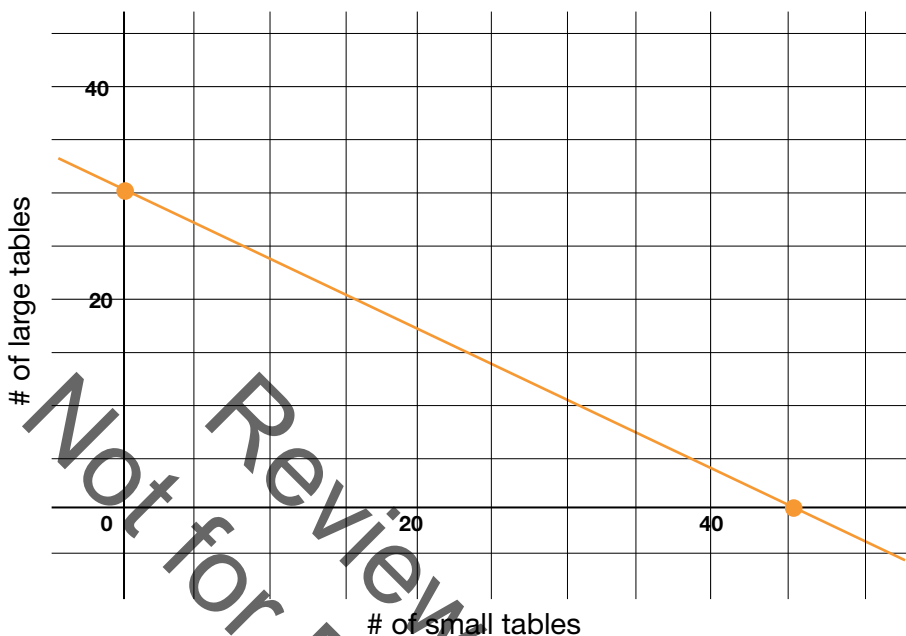

Teacher writes an equation to model each situation, but uses a table to assist in the graphing process for each situation.

**Note:** These two example problems and more can be found at:

<http://www.iss.k12.nc.us/cms/lib4/NC01000579/Centricity/Domain/4949/Math%20II/Linear%20Applications.doc>

### Practice Together in Small Groups / Individually

#### PRI 7

Students will practice in pairs graphing each situation. The Teacher should rotate among the pairs of students formatively assessing and asking probing questions as necessary. Only one handout is needed per pair.

INCLUDED IN THE STUDENT MANUAL

#### Task #2: Practice Together

- 1) Tim buys a new computer for his office for \$1200. For tax purposes, he declares a linear depreciation (loss of value) of \$200 per year. Let  $y$  be the declared value of the computer after  $x$  years.
  - What is the slope of the line that models this depreciation?
  - Find the  $y$ -intercept of the line.
  - Write a linear equation in slope-intercept form to model the value of the computer over time.
  - Find the value of the computer after 4.5 years.
- 2) An attorney charges a fixed fee on \$250 for an initial meeting and \$150 per hour for all hours worked after that.

- Write an equation in slope-intercept form.
  - Find the charge for 26 hours of work.
- 3) A submarine designed to explore the ocean floor is at an elevation of 13,000 feet (below sea level). The submarine ascends to the surface at an average rate of 650 feet per minute.
- Write an equation in slope-intercept form.
- 4) Wendy is starting a catering business and is attempting to figure out who she should be using to transport the food to different locations. She has found two trucking companies that are willing to make sure her food arrives intact. Peter's Pick Up charges \$0.40 per mile and charges a flat fee of \$68. Helen's Haulers charges \$0.65 per mile and charges a flat fee of \$23.
- Define your variables.
  - Write an equation for each company to model the situation above.
  - For what distance would the cost of transporting to the produce be the same for both companies? What is that equal cost? Use mathematics to explain how you determined your answer. Use words, symbols or both in your explanation.
  - Which company charges a lower fee for a 160 mile trip? Use mathematics to justify your answer.
  - Which company will move a greater distance for \$200? Use mathematics to justify your answer.
- 5) Max sells lemonade for \$2 per cup and candy for \$1.50 per bar. He earns \$425 selling lemonade and candy.
- Write a linear model that relates the number of cups of lemonade he sold to the number of bars of candy he sold.
  - If Max sold 90 bars of candy, how many cups of lemonade did he sell?
- 6) The model  $2x + 5y = 85$  can be used to model how much money Tim spent on  $x$  sodas and  $y$  sandwiches.
- If he bought 15 sodas, how many sandwiches did he purchase?
- 7) At a school play, children's tickets cost \$3 each and adult tickets cost \$7 each. The total amount of money earned from ticket sales equals \$210.
- Write and graph a linear model that relates the number of children's tickets sold to the number of adult tickets sold. Let  $x$  represent the number of children's tickets sold and let  $y$  represent the number of adult tickets sold.

**Possible Answers:**

- 1) Tim buys a new computer for his office for \$1200. For tax purposes, he declares a linear depreciation (loss of value) of \$200 per year. Let  $y$  be the declared value of the computer after  $x$  years.
- What is the slope of the line that models this depreciation?  $-200$
  - Find the  $y$ -intercept of the line.  $1,200$
  - Write a linear equation in slope-intercept form to model the value of the computer over time.  $Y = -200x + 1,200$
  - Find the value of the computer after 4.5 years.  $300$

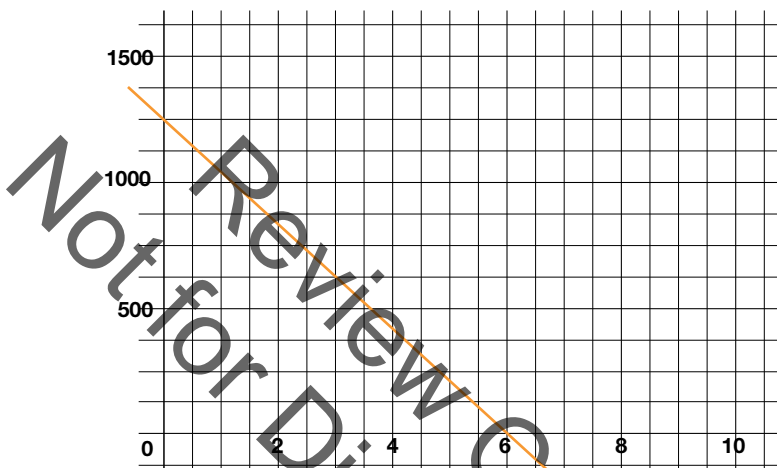

- 2) An attorney charges a fixed fee on \$250 for an initial meeting and \$150 per hour for all hours worked after that.
- Write an equation in slope-intercept form.  $Y = 150x + 250$
  - Find the charge for 26 hours of work.  $\$4,750$

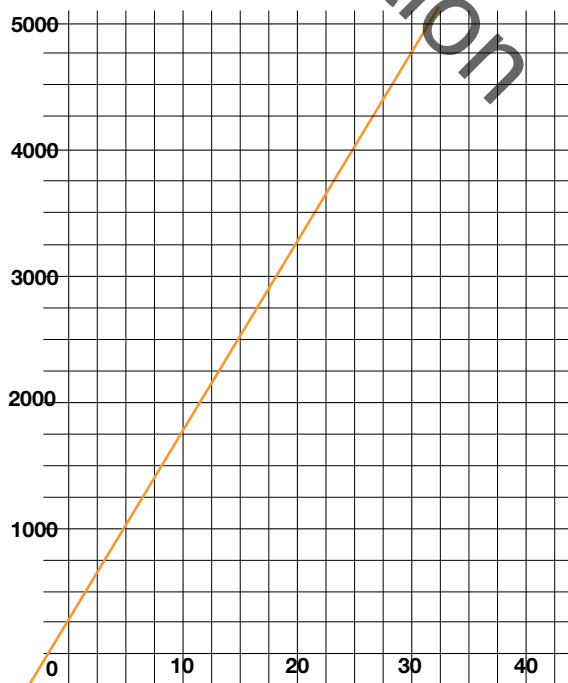

- 3) A submarine designed to explore the ocean floor is at an elevation of 13,000 feet (below sea level). The submarine ascends to the surface at an average rate of 650 feet per minute.

- Write an equation in slope-intercept form.  $Y = 650x - 13,000$

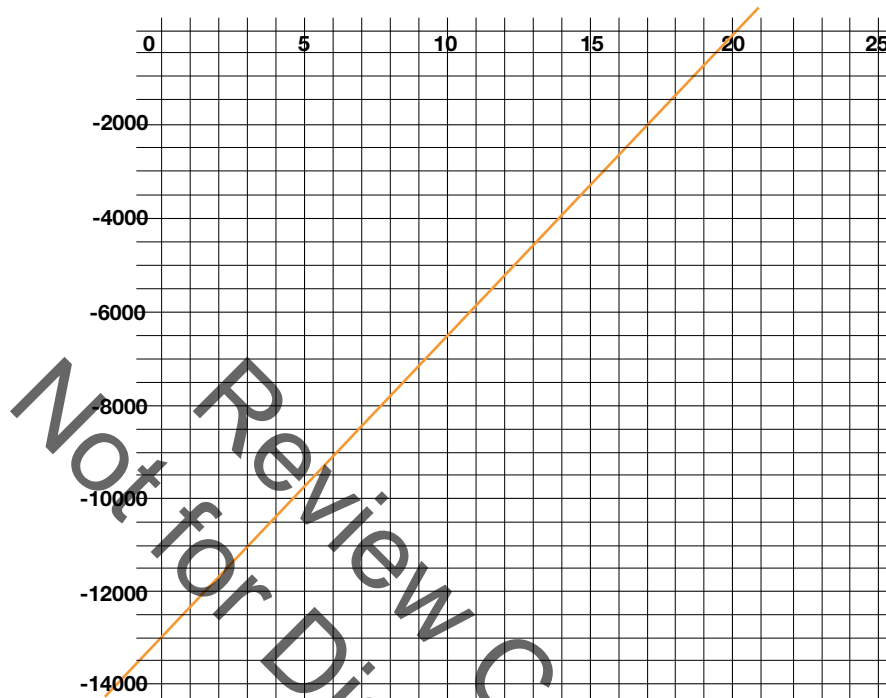

- 4) Wendy is starting a catering business and is attempting to figure out who she should be using to transport the food to different locations. She has found two trucking companies that are willing to make sure her food arrives intact. Peter's Pick Up charges \$0.40 per mile and charges a flat fee of \$68. Helen's Haulers charges \$0.65 per mile and charges a flat fee of \$23.

- Define your variables.  $M = \# \text{ of miles}$ ,  $T = \text{total cost}$
- Write an equation for each company to model the situation above.  
*Peter's Pickup:  $T = 0.4m + 68$*   
*Helen's Haulers:  $T = 0.65m + 23$*
- For what distance would the cost of transporting to the produce be the same for both companies? ? *180 miles* What is that equal cost? *\$140*
- Which company charges a lower fee for a 160 mile trip? Use mathematics to justify your answer. *Helen's Haulers is less expensive and costs \$127 for a 160 mile trip opposed to the competition which charges \$132.*
- Which company will move a greater distance for \$200? Use mathematics to justify your answer. *You will get more for your money with Peter's Pickup if you spend \$200.*



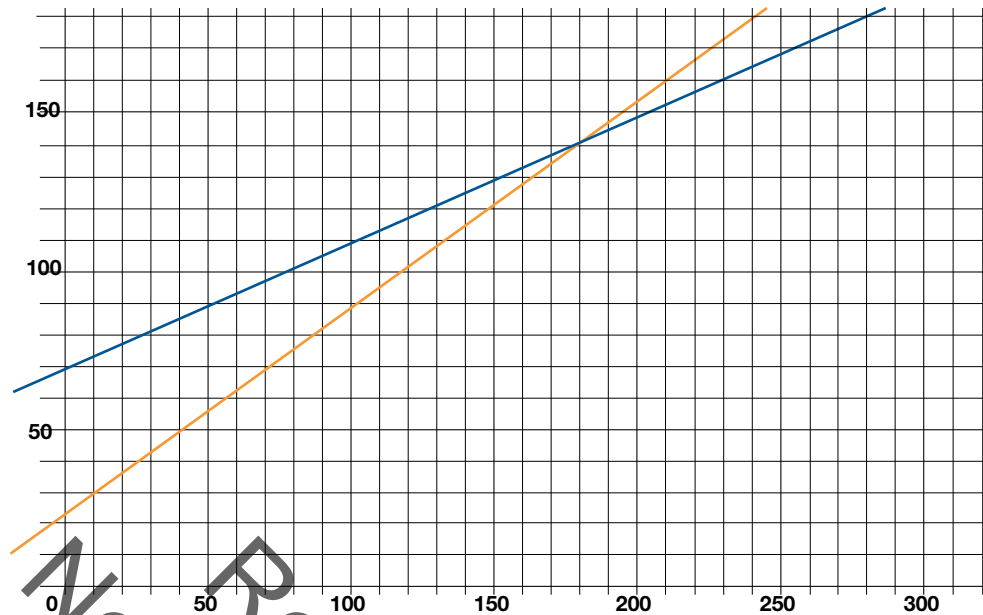

- 5) Max sells lemonade for \$2 per cup and candy for \$1.50 per bar. He earns \$425 selling lemonade and candy.
- Write a linear model that relates the number of cups of lemonade he sold to the number of bars of candy he sold.  $2c + 1.5b = 425$
  - If Max sold 90 bars of candy, how many cups of lemonade did he sell? *145 cups of lemonade*

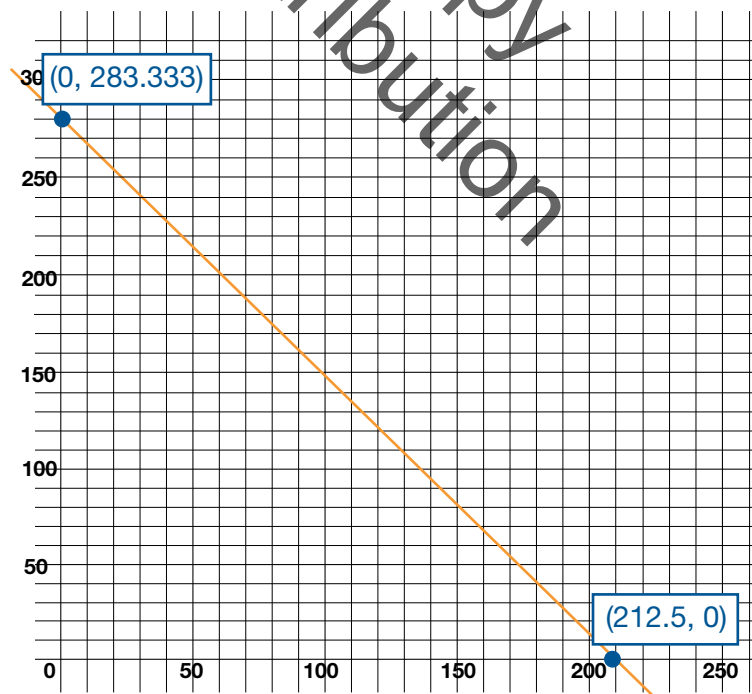

6) The model  $2x + 5y = 85$  can be used to model how much money Tim spent on  $x$  sodas and  $y$  sandwiches.

- If he bought 15 sodas, how many sandwiches did he purchase? *11 sandwiches*

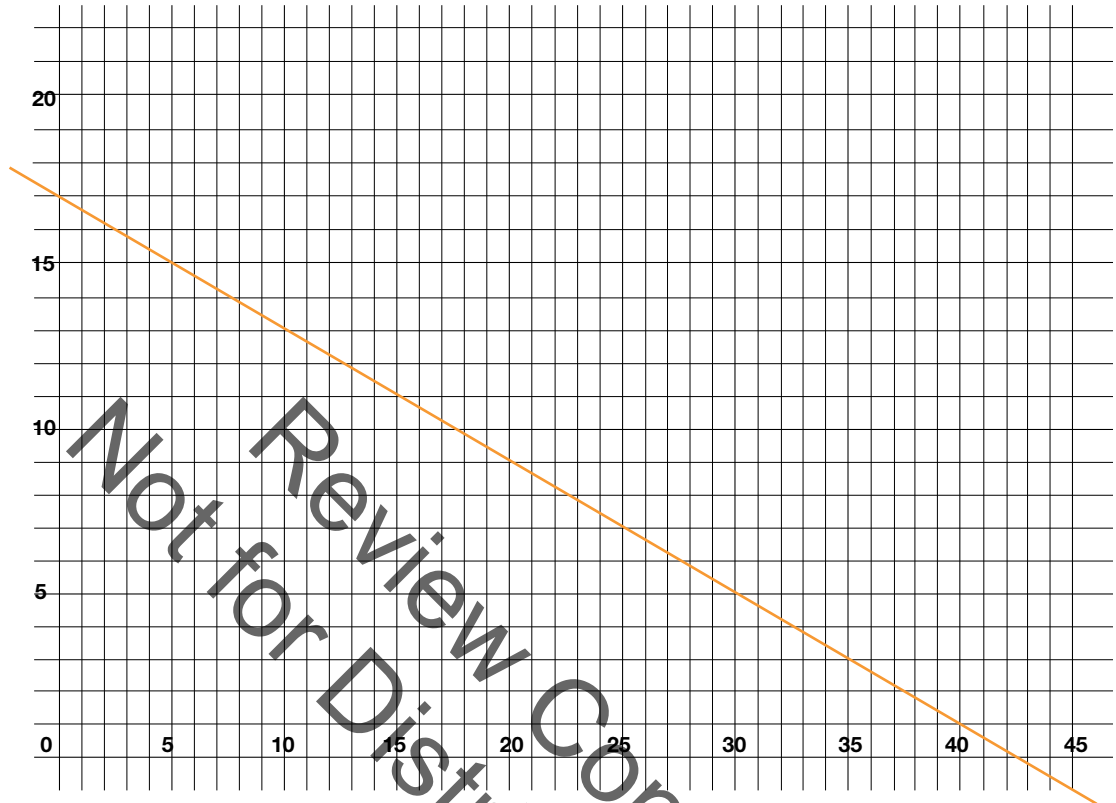

7) At a school play, children's tickets cost \$3 each and adult tickets cost \$7 each. The total amount of money earned from ticket sales equals \$210.

- Write and graph a linear model that relates the number of children's tickets sold to the number of adult tickets sold. Let  $x$  represent the number of children's tickets sold and let  $y$  represent the number of adult tickets sold.  $3x + 7y = 210$

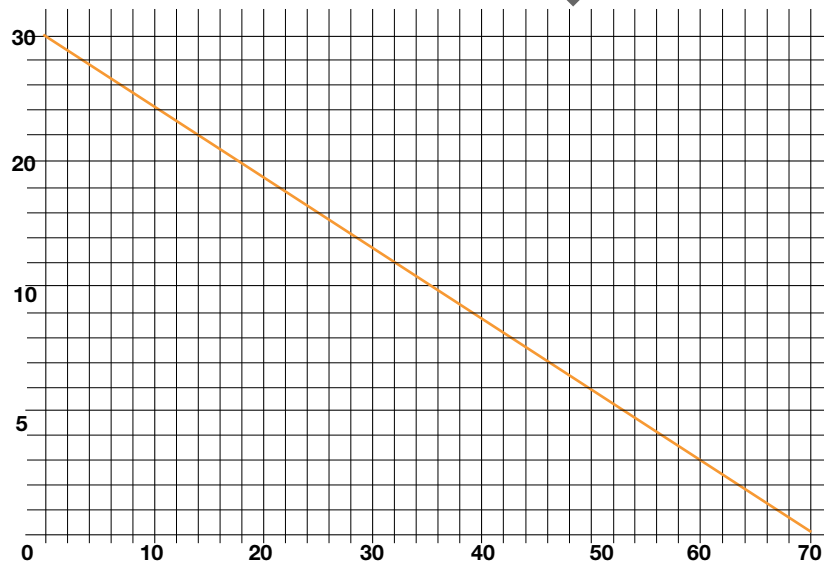

Note: These problems have been adapted from:

[https://www.nsa.gov/academia/\\_files/collected\\_learning/high\\_school/algebra/real\\_world\\_systems\\_of\\_linear\\_equations.pdf](https://www.nsa.gov/academia/_files/collected_learning/high_school/algebra/real_world_systems_of_linear_equations.pdf)

<http://www.mlbgd.k12.pa.us/cms/lib/PA09000085/Centricity/Domain/75/Graphing%20Word%20Problems%20Standard%20Form.pdf>

<http://www.lsrhs.net/departments/mathematics/DoreyB/2014Algebra/Lines/linear%20word%20problems%20.pdf>

## Evaluate Understanding

### PRI 4

Task #3 - Evaluate Understanding in Student Manual. Students are instructed to work independently.

*Teacher's Note: Students should ask: What is the 8th grade student population? Provide them with this information.*

INCLUDED IN THE STUDENT MANUAL

### Task #3 Evaluate Understanding

You're hired! The 8th graders need to order a new class shirt for the GRAD night. All profits will be used to fund the 8th grade dance. Which company should we select?

- Local Promotion & Printing Company: The class shirts can be printed by a local company for a cost of \$9.50 per shirt with an initial cost of \$50 for typesetting.
- PTA member's T-shirt business: A parent charges \$11 per shirt and will waive any set up fees.

Possible Answers:

- Local Promotion & Printing Company: The class shirts can be printed by a local company for a cost of \$9.50 per shirt with an initial cost of \$50 for typesetting.  
 $Y = 9.5x + 50$
- PTA member's T-shirt business: A parent charges \$11 per shirt and will waive any set up fees.  $Y = 11x$
- Students are asked to graph the situation and interpret the graphs to answer the question. *It is cheaper to use the PTA if at most 33 t-shirts are ordered. It is cheaper to use the Local company if 34 or more shirts are ordered.*

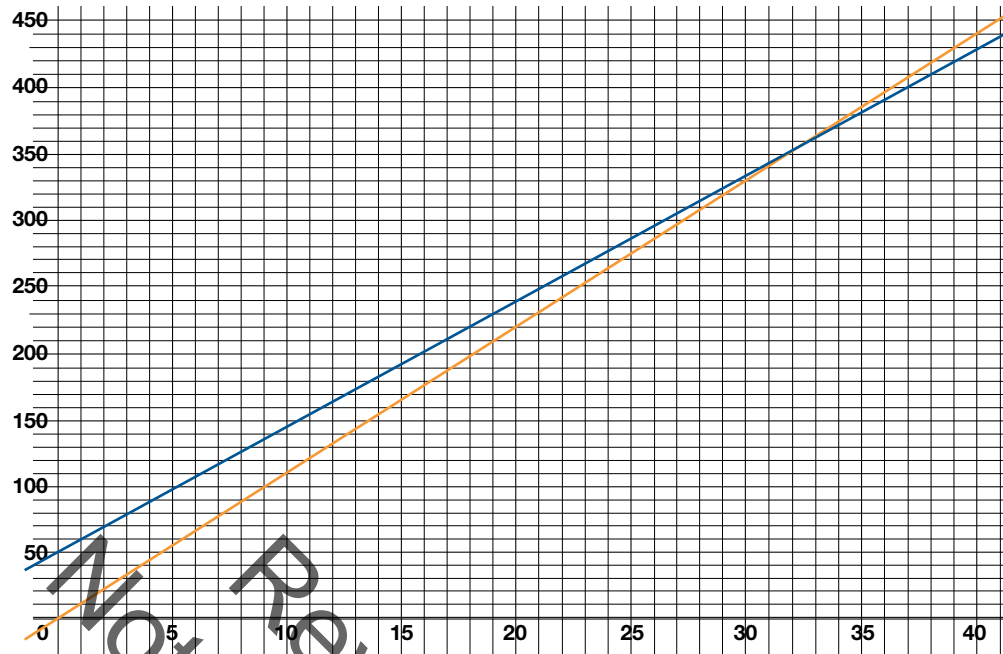

### Closing Activity

---

Exit Slip: How is graphing equations in slope intercept form and standard form similar?  
How is it different?

### Independent Practice:

---

<https://www.khanacademy.org/math/cc-eighth-grade-math/cc-8th-linear-equations-functions/8th-linear-functions-modeling/e/graphing-linear-functions-word-problems>

<https://www.khanacademy.org/math/cc-eighth-grade-math/cc-8th-linear-equations-functions/8th-linear-functions-modeling/e/constructing-linear-functions-word-problems>

### Resources/Instructional Materials Needed:

---

- Stopwatch
- School Map
- Graph Paper
- Task #2: Practice Together
- Task #3: Evaluate Understanding

## Systems of Equations

# Lesson 3 of 9

## Systems of Linear Equations

### College- and Career-Readiness Standards Addressed:

---

Represent and analyze quantitative relationships between dependent and independent variables.

- EE.5 Use variables to represent two quantities in a real-world problem that change in relationship to one another; write an equation to express one quantity, thought of as the dependent variable, in terms of the other quantity, thought of as the independent variable. Analyze the relationship between the dependent and independent variables using graphs and tables, and relate these to the equation. *For example, in a problem involving motion at constant speed, list and graph ordered pairs of distances and times, and write the equation  $d = 65t$  to represent the relationship between distance and time.*

Analyze and solve linear equations and pairs of simultaneous linear equations.

- EE.15 Analyze and solve pairs of simultaneous linear equations.
  - a. Understand that solutions to a system of two linear equations in two variables correspond to points of intersection of their graphs, because points of intersection satisfy both equations simultaneously.
  - b. Solve systems of two linear equations in two variables algebraically, and estimate solutions by graphing the equations. Solve simple cases by inspection. For example,  $3x + 2y = 5$  and  $3x + 2y = 6$  have no solution because  $3x + 2y$  cannot simultaneously be 5 and 6.
  - c. Solve real-world and mathematical problems leading to two linear equations in two variables. For example, given coordinates for two pairs of points, determine whether the line through the first pair of points intersects the line through the second pair.

### Mathematical Process Readiness Indicator(s) Emphasized:

---

- PRI 1: Make sense of problems and persevere in solving through reasoning and exploration.
- PRI 3: Describe and justify mathematical understandings by constructing viable arguments, critiquing the reasoning of others and engaging in meaningful mathematical discourse.
- PRI 4: Contextualize mathematical ideas by connecting them to real-world situations. Model with mathematics.
- PRI 6: Attend to precision.
- PRI 7: Look for and make use of patterns and structure.

Sequence of  
Instruction

Activities Checklist

Engage

PRI 1  
PRI 4  
PRI 9

*Teacher Note:* You will need a helium filled balloon and a non-helium filled balloon for a hot air balloon simulation. The balloons need to be the same size and type.

Have one student hold the helium balloon near the floor and another hold the other balloon as high as they can safely. Let the balloons go at the same time and have students watch the demonstration.

How can we model what just happened mathematically?

Ask students in pairs to discuss what they saw and how could they describe it mathematically.

Sample responses:

- *One balloon is rising. One balloon is descending.*
- *One balloon rate is faster than the other.*
- *The balloons pass each other a few seconds after they are released.*
- *If we had a stop watch we could time the balloons.*
- *If we had a tape measure we could measure how far the balloons travel.*
- *If we have the time and distance we could calculate a rate or speed.*
- *We could graph their heights.*

Students should approach this as an experiment and what could they prove or what questions could be asked and answered. Let students discuss different ideas as to what this demonstration would show.

Give them a few minutes to discuss and write their ideas. After a few minutes have the students share their mathematical representations and ideas.

Ask questions such as: What if they had more data? Could they represent anything else mathematically? Students should respond with ideas like how fast they go up or down, how long before they pass each other, when do they pass each other with respect to time or height, etc.

Explore

PRI 1  
PRI 4  
PRI 5  
PRI 6  
PRI 7  
PRI 9

Collect some data. You will need a stop watch, tape measure or meter stick, and the balloons.

*Teacher Note:* As you set up this experiment, let students think about what data they need to collect. Give time for students to come up with their best method or strategy.

Task #4: Balloons:

Have one student hold the helium filled balloon next to the floor, and have another student stand as high as they can safely with the non-helium balloon. You will need to measure the height at which the student releases the balloon. Have another student designated as the timer. Have someone say go and start the timer as both students let go of the balloons. As the one goes up and the other goes down have the students observe when they are at the same level, and yell stop. The timer should stop when they are at the same level. Now discuss the time and movement of the balloons and how they might be represented mathematically (i.e., At 3 seconds, both balloons are at the same distance from the ground.)



Now have students create a linear equation that relates the time and distance for the balloons. Helium balloon might be, for example, 3 inches per second. The non-helium balloon might be slower, maybe 2 inches per second. You need to set up the parameters for the rate for your students. You can also then talk about speed and mile per hour and have them convert the rate into something they can understand.

Here are two sample equations:  $y = 3x$  and  $y = 2x + 12$

Using the two equations that your class formulates, make a chart of data to represent the time and the height of the balloons. Data is based on above equations. Actual DATA will vary.

Time in seconds Helium Balloon Height

Time in seconds	Helium Balloon Height	Regular Balloon Height
0	0	12
1	3	10
2	6	8
3	9	6
4	12	-4

Pose the question: When did the two balloons have the same height according to our data charts? How does this relate to the actual timed height?

*Reminder: The data chart and using the equations is the main focus of the lesson. Do not get so caught up in the simulation that the students lose focus on the data. Getting an answer between 2 and 3 seconds is good enough for the demonstration. If you have advanced students, they can solve or test and guess to get a closer answer. Encourage them to find a more exact answer. Discuss what a good enough answer is for this experiment. The solution to the question being posed is what is important. Stress to the students that the approximate time and height is the order pair of the solution.*

## Explanation

- PRI 1
- PRI 2
- PRI 4
- PRI 5
- PRI 6
- PRI 7
- PRI 9
- PRI 10

### INCLUDED IN THE STUDENT MANUAL

#### Task #4: Balloons (contd.)

##### Part 2:

A hot air balloon is 70 meters above the ground and is descending at a constant rate of 6 meters per second. While another balloon that is 10 meters from the ground is rising at a constant rate of 15 meters per second.

How far from the ground will the two balloons be after 10 seconds?

When will the two balloons be at the same height above the ground?

How far above the ground will the two balloons be when they meet?





Have students create data charts to represent the two balloons. Have them record the data in the charts for each balloon. Depending on the class, you might have to discuss what time increments you should use (i.e., whole seconds or half seconds). After the data charts are completed for the 10 seconds, then have the discussion as to what that data means and when the balloons will be at the same height. From the chart, the answer is between 2 and 3 seconds. Pose the question: How can we get a more precise time? (divide the time into smaller increments) The data then shows the answer is between 2.5 and 3 seconds or 2.8 and 2.9 seconds. How can we get the exact time?

*Teacher note:* The chart can be reproduced using a spread sheet or the table function on the graphing calculator, but the practice of substituting the value in for  $x$  or the thought process of what is happening in each time increment is crucial for students to understand. The making use of patterns with repeated reasoning is the focus. Have the students think through each time interval for each balloon. If a student on their own used technology don't discourage but make sure the student understands the mathematical process that is occurring. Remember the main focus of the problem is to look at the data and decide when the two balloons will be at the same height and what that solution is. Getting the answer between 2 and 3 seconds and between 58 and 55 meters is sufficient to understand the solution to this situation.

Pose these questions to students:

- Other than a data chart does anyone have an idea as to how we could possibly find the solution to when the two the balloons pass more precisely?
- Can you create two equations from the data?

Depending on the class, you might want to choose two points on the line and create an equation or use the information from the problem to create equations in slope-intercept form. Make sure you discuss the importance of the rates being the slopes and the beginning heights being the  $y$ -intercepts.

Equation 1:  $y = 70 - 6x$ ; Equation 2:  $y = 10 + 15x$

Whole group discussion:

- What does the  $x$  represent in the equations? (*time in seconds*)
- What does the  $y$  represent in the equations? (*height in meters*)
- What is the slope for each equation and what does it represent? (*rate of height per second*)
- What is the  $y$ -intercept for each equation and what does it represent? (*the height of the balloon at 0 time. The height of the balloon at the beginning of the experiment.*)
- If the  $y$  represents the height of the balloon, how can we show when both balloons are at the same height? (*when  $Y$ 's are the same in both equations, students now need to find the  $X$  value to make the  $Y$ 's the same*)

*Note:* This problem will be revisited in lesson 7 of this unit where substitution is discussed to solve system of equations.

Another example similar to this can be found at <http://illuminations.nctm.org/Lesson.aspx?id=2808>

The pre-activity is the focus for this lesson but the entire activity is beneficial.

Using a table of values to solve systems of equations can be used with other types of linear equations as well.

Students will now apply what they learned from the Balloons task to a similar scenario. Teacher note: Students do not have to develop formal equations. Try to let students develop the equations from the data instead of creating data from equations. The repetition of thinking about what is happening in the situation is critical.

Task #5: Jerseys

INCLUDED IN THE STUDENT MANUAL

**Task #5: Jerseys**

Kristin spent \$157 on jerseys for her team and one shirt for her coach. Home jerseys cost \$28 each and away jerseys cost \$15 each.

If she bought a total of 7 jerseys, how many of each kind did she buy?

Home jersey	\$28 each	Away jersey	\$15 each	Cost

Create equations that can be used to represent the data.

---



---

What question are you answering for this problem?

---



---

How would you represent it mathematically?

---



---

What is the solution?

---



---

Possible Answers:

Let H represent home jerseys and A represent away jerseys.

$H + A = 7$ . Also an equation to represent the cost of the jerseys is  $28H + 15A = 157$ .

Home jersey	\$28 each	Away jersey	\$15 each	Cost
7	$7(28)$	0	$0(15)$	196
6	$6(28)$	1	$1(15)$	183
5	$5(28)$	2	$2(15)$	170
4	$4(28)$	3	$3(15)$	157
3	$3(28)$	4	$4(15)$	144
2	$2(28)$	5	$5(15)$	131
1	$1(28)$	6	$6(15)$	118
0	$0(28)$	7	$7(15)$	105

How many did she buy for \$157? *She bought 4 home jerseys and 3 away jerseys, because  $4 + 3$  is 7 total jerseys and  $28(4) + 15(3)$  is \$157.* Always make the student explain what the solution is and why they think it is correct.

**Practice Together / in Small Groups / Individually**

- PRI 1
- PRI 2
- PRI 3
- PRI 4
- PRI 7
- PRI 8

Additional practice problems can be found at the following link:

<http://cdn.kutasoftware.com/Worksheets/PreAlg/Systems%20Word%20Problems.pdf>

**Evaluate Understanding**

- PRI 1
- PRI 2
- PRI 3
- PRI 4
- PRI 7
- PRI 8

TASK #6: Basketball Tickets

INCLUDED IN THE STUDENT MANUAL

**Task #6: Basketball Tickets**

At a state basketball tournament game 15 tickets were sold to one group. Adult tickets are \$17 each and student tickets are \$6 each.

If the group leader paid \$167 for the group, how many student tickets did he purchase?

Adult Tickets	Student Tickets	Total cost

Create equations that can be used to represent the data.

---



---

What question are you answering for this problem?

---



---

How would you represent it mathematically?

---



---

What is the solution?

---



---

Possible Answers:

Adult Tickets	Student Tickets	Total cost
3	12	123
4	11	134
5	10	145
6	9	156
7	8	167
8	7	178

Students can use a table of values or they can write and solve two equations.

$X + Y = 15$ ,  $17X + 6Y = 167$

From the table of values discuss the answer to the problem. Discuss how can you tell that your answer should be 7 adult and 8 students. The solution is (7,8). What does (7,8) mean to the problem? Students should not be allowed to just say (7,8) is my solution. Students should always follow the solution with an explanation ie. (7,8) is the solution that means there are 7 adult tickets and 8 student tickets because 7 + 8 is 15 tickets and 17(7) + 6(8) is \$167.

**Independent Practice:**

<http://cdn.kutasoftware.com/Worksheets/PreAlg/Systems%20Word%20Problems.pdf>

### Resources/Instructional Materials Needed:

---

Helium filled latex balloon  
Regular air filled latex balloon same size as the helium balloon  
Stop watch  
Tape measurer or meter(yard) stick  
Graph paper or chart paper  
Task #4: Balloons  
Task #5: Jerseys  
Task #6: Basketball Tickets

### Notes:

---

Though the main focus of this lesson is to solve a system of equations using a table of values, they can also be solved by graphing. The point is to recall that graphs are created from data that arise from the relationships that are represented by equations. If students want to solve the systems using different methods, allow this but have them explain their methods.

Not for Review Copy  
Not for Distribution

## Systems of Equations

# Lesson 4 of 9

## Systems of Linear Equations

### College- and Career-Readiness Standards Addressed:

---

Analyze and solve linear equations and pairs of simultaneous linear equations.

- EE.14 Solve linear equations in one variable.
  - a. Give examples of linear equations in one variable with one solution, infinitely many solutions, or no solutions. Show which of these possibilities is the case by successively transforming the given equation into simpler forms, until an equivalent equation of the form  $x = a$ ,  $a = a$ , or  $a = b$  results (where  $a$  and  $b$  are different numbers).

Analyze and solve linear equations and pairs of simultaneous linear equations.

- EE.15 Analyze and solve pairs of simultaneous linear equations.
  - a. Understand that solutions to a system of two linear equations in two variables correspond to points of intersection of their graphs, because points of intersection satisfy both equations simultaneously.

### Mathematical Process Readiness Indicator(s) Emphasized:

---

- PRI 1: Make sense of problems and persevere in solving through reasoning and exploration.
- PRI 3: Describe and justify mathematical understandings by constructing viable arguments, critiquing the reasoning of others and engaging in meaningful mathematical discourse.
- PRI 4: Contextualize mathematical ideas by connecting them to real-world situations. Model with mathematics.
- PRI 6: Attend to precision.
- PRI 7: Look for and make use of patterns and structure.

## Engage

### PRI 1

INCLUDED IN THE STUDENT MANUAL

#### Task #7: Test Questions

##### Part I:

This equation represents the total number of questions on your next test.  $x$  represents the number of multiple choice;  $y$  represents the number of free response questions.

$$y + x = 17$$

How many of each question type are on your next test?

---

---

---

Students may respond with white boards and dry erase markers. If a student remarks that there are a bunch of possibilities the teacher should encourage the students to create a table to list all of the possibilities.

After a few minutes the teacher asks: What is the solution? How do you know?

*This may be a good place to discuss domain and range.*

If the students say there isn't enough information, then ask what information they would like. They may quickly reply: How many essay questions are on the test?

Teacher then asks: Can you explain how you would determine the solution with that information?

The teacher then explains how knowing the number of essay questions would immediately give away the answer to the number of multiple choice questions.

Rather, the teacher should provide the students with another clue:





## Explanation

Teacher asks:

- What are the solutions to an equation with two variables?
- What are the solutions to  $x + y = 17$ ?

Teacher graphs the line  $x + y = 17$  from Part I. Then the teacher asks: What ordered pair is not a solution to  $x + y = 17$ ?

Teacher emphasizes that points on the line make the equation true when they are substituted into the equation, while points that are not on the line are not solutions.

Teacher graphs the second equation  $2x + 4y = 40$  from Part II and asks for solutions and non-solutions for that line.

Teacher explains:

The two equations together in our introductory tasks (Parts I and II) create a system of linear equations. A system of equations is two or more equations with two or more variables. Since all of the solutions to a linear equation are the ordered pairs on the line that is graphed, the solution to the system is the ordered pair that falls on both lines, also known as the point of intersection.

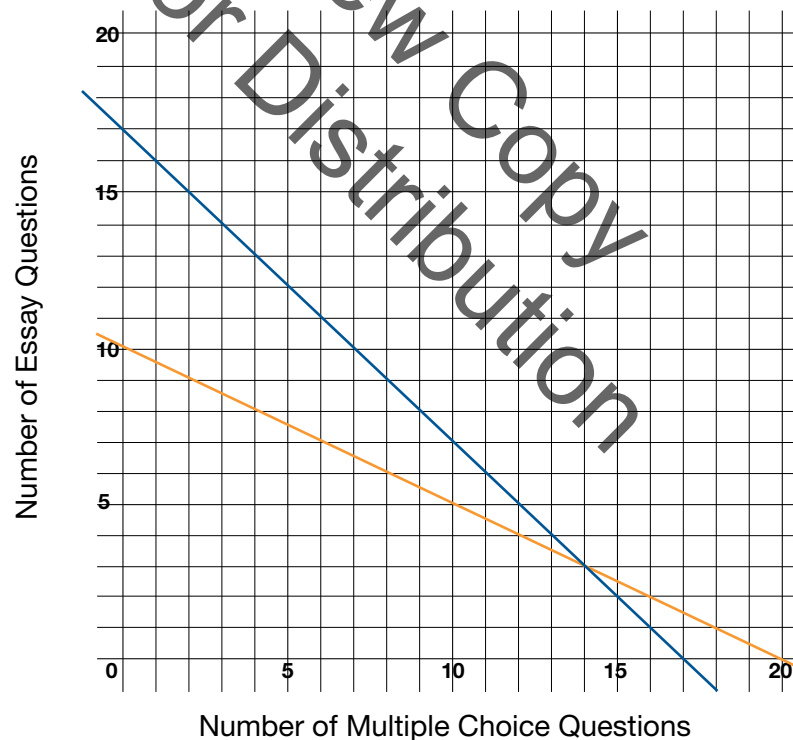

## Explore

### PRI 7

Teacher asks the students to graph the following systems and see if they can decide if the system has one, none or many solutions.

INCLUDED IN THE STUDENT MANUAL

**Task #7: Test Questions**

**Part 3:**

Graphs of Systems

$$\text{A) } \begin{cases} y = -\frac{1}{2}x - 1 \\ y = \frac{1}{4}x - 4 \end{cases} \quad \text{B) } \begin{cases} y = \frac{2}{3}x - 2 \\ 2x - 3y = 6 \end{cases} \quad \text{C) } \begin{cases} 2x + y = 5 \\ 2x + y = 2 \end{cases}$$

Graph the above equations on the same set of axes.

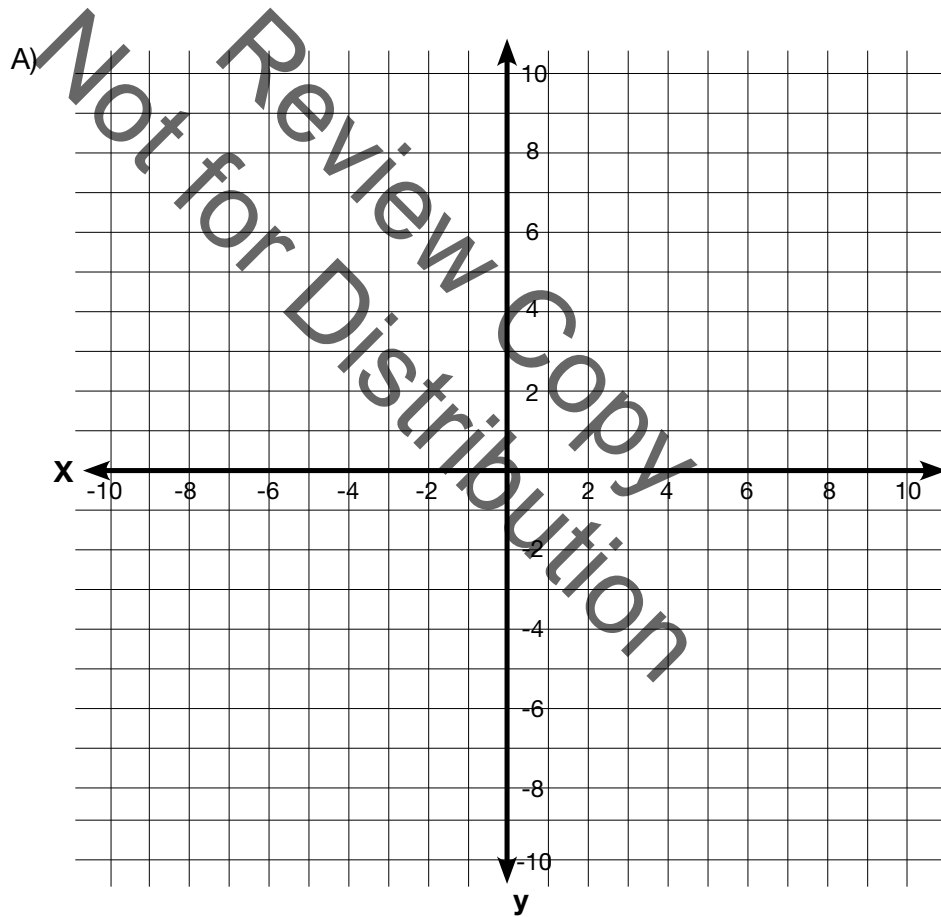

B)

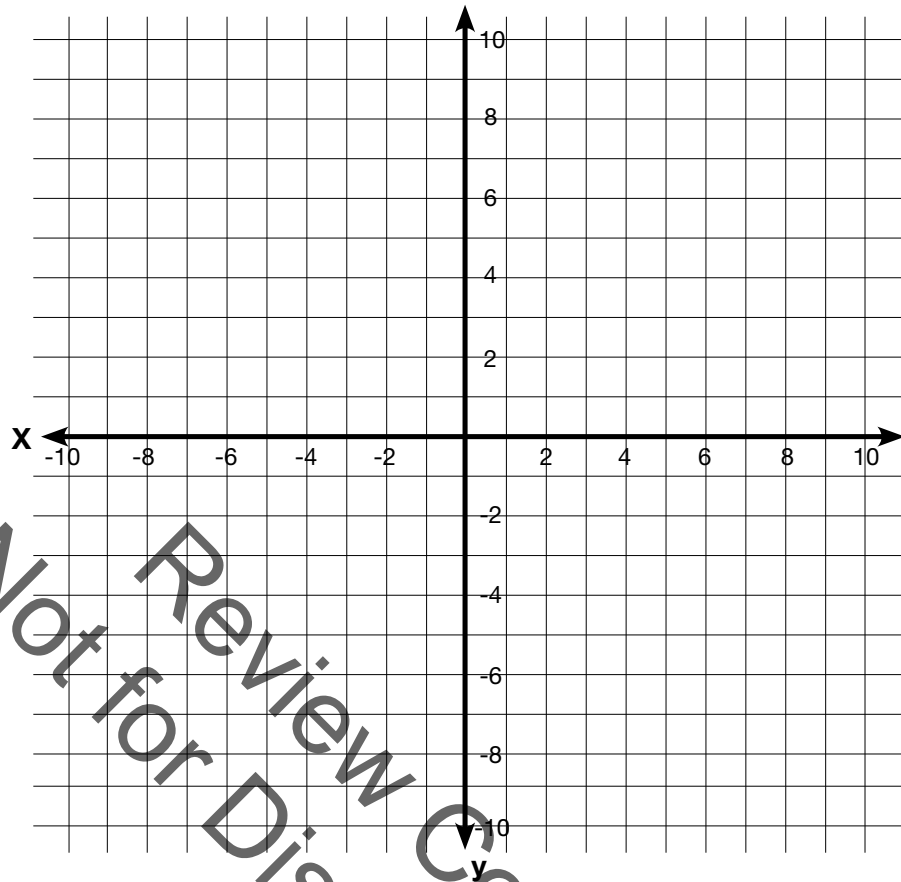

C)

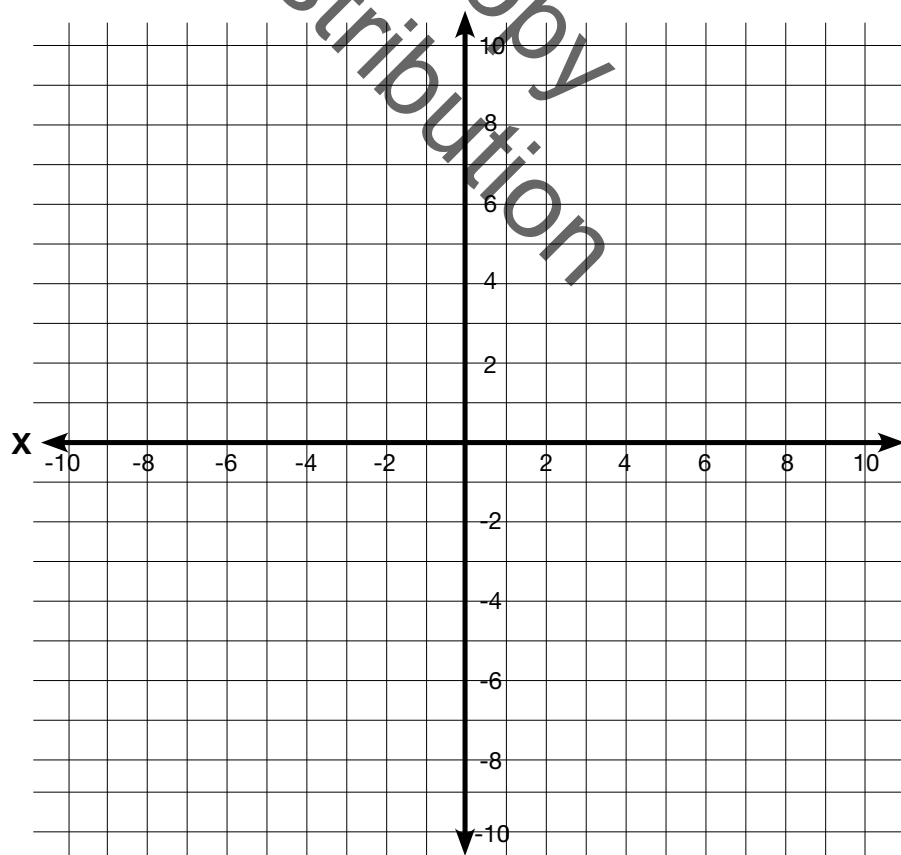

Each of these are a system of equations. The solution to a system of equations is the set of all points that satisfy both equations. With that definition of solution answer the following questions?

How many solutions does set A have? \_\_\_\_\_

How many solutions does set B have? \_\_\_\_\_

How many solutions does set C have? \_\_\_\_\_

How can you tell by the equations how many solutions each will have?

---



---



---

Possible Answers:

A) 
$$\begin{cases} y = -\frac{1}{2}x - 1 \\ y = \frac{1}{4}x - 4 \end{cases}$$

B) 
$$\begin{cases} y = \frac{2}{3}x - 2 \\ 2x - 3y = 6 \end{cases}$$

C) 
$$\begin{cases} 2x + y = 5 \\ 2x + y = 2 \end{cases}$$

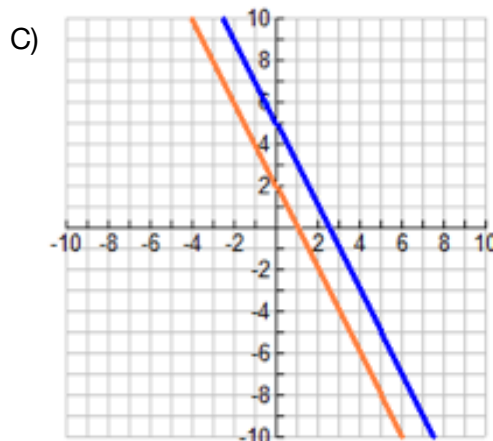
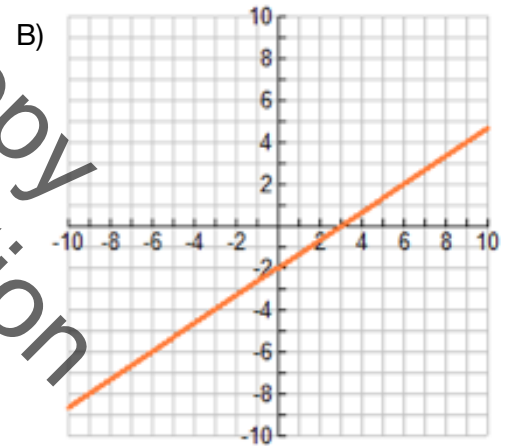
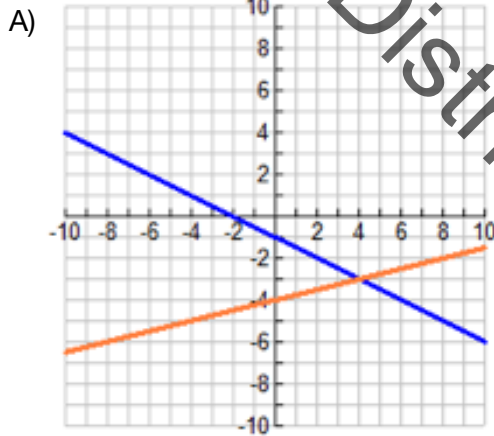

The teacher works out the three explore activity situations by graphing and then explains the solutions in each situation:

Sometimes, the lines are the same line, such as in system B. In this case, every point on the first line is also a point on the second line. This system has infinitely many solutions.

Sometimes the lines are parallel, such as in system C. In this case, there are no points in common; therefore, this system has no solution.

Key: One Solution: A

Infinitely many solutions: B

No solution: C

Teacher asks: Is there a way to determine whether a system of equations has one, none or infinitely many solutions just by looking at the equations involved?

Hopefully, students notice that in system B, the slopes and y-intercepts are the same, and in system C, the slopes are the same but the y-intercepts are different.

### Practice Together / in Small Groups / Individually

Students solve the following practice problems with their elbow partner using the Kagan “Rally Coach” cooperative learning strategy. There is one pencil and one piece of paper per the pair. Each student takes a turn writing and explaining their thought process. Roles switch following each practice problem. The partner that is not writing is the ‘Coach’ and verbally helps their partner work the problem and arrive at the correct answer.

INCLUDED IN THE STUDENT MANUAL

#### Task #8: Systems of Equations Practice

Graph the following systems of equations to find the solution to each system.

$$1. \begin{cases} y = -4x + 5 \\ y = 3x - 9 \end{cases}$$

$$2. \begin{cases} y = -3x + 7 \\ y = 2x - 3 \end{cases}$$

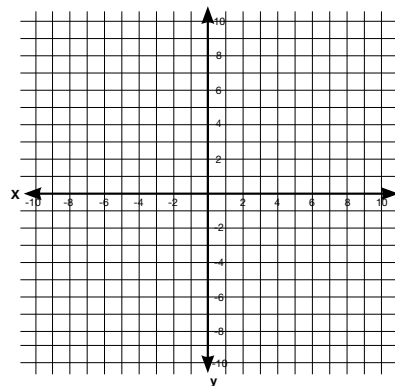
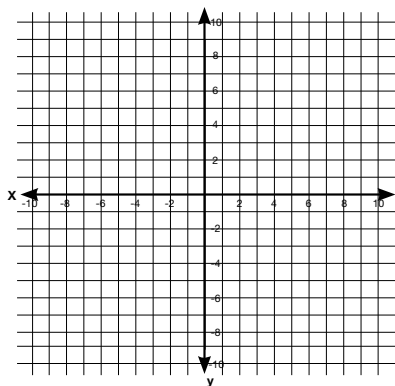

$$3. \begin{cases} x + 3y = 6 \\ x - 3y = 6 \end{cases}$$

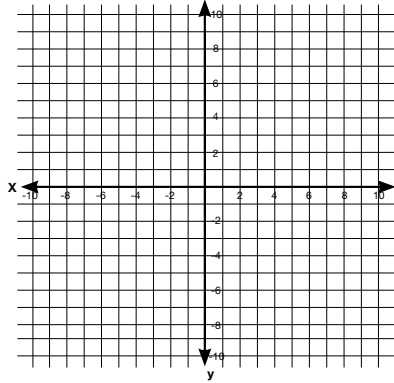

$$4. \begin{cases} y = x + 6 \\ y = -2x \end{cases}$$

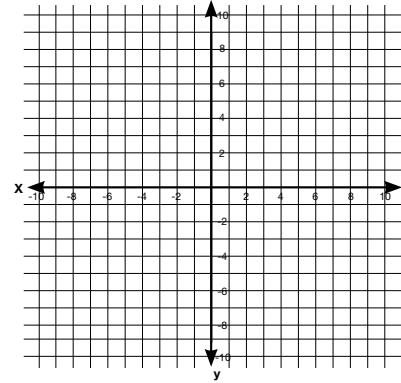

$$5. \begin{cases} y = 4x - 3 \\ y = -2x + 9 \end{cases}$$

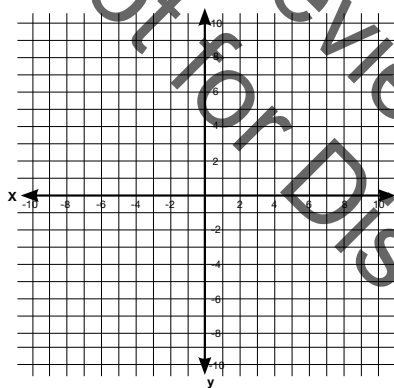

$$6. \begin{cases} 3x - 2y = 4 \\ y = -2x + 5 \end{cases}$$

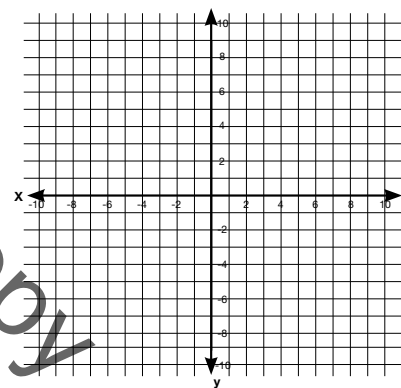

$$7. \begin{cases} 3x - 2y = 6 \\ x - y = 2 \end{cases}$$

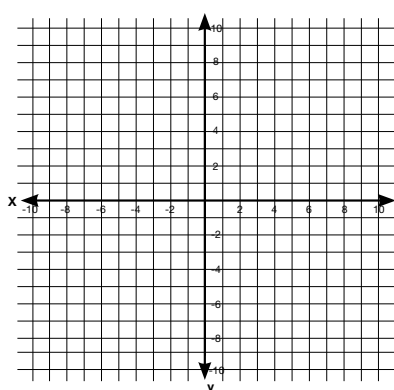

$$8. \begin{cases} x + y = 4 \\ 2x + 2y = 10 \end{cases}$$

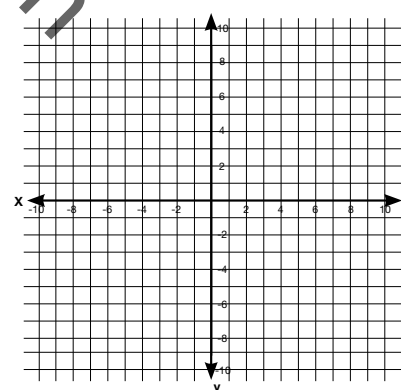

Not for Review Copy  
Distribution

Practice Problems Adapted from:

<http://literacy.kent.edu/eureka/EDR/9/Math%20SolvingSystemsofLinearEquations-Graphing.pdf>

**Whole group discussion:**

**Teacher asks:** Which systems have No Solution? What type of lines are they? How do you know from an equation and a graph that you have parallel lines?

Which system has infinitely many solutions? What is one of the solutions of this system? What is a non-solution for this system?

How can we check that (2,-3) is the unique solution for the system of equations in the first practice problem?

*While discussing the answers to the above questions, the teacher should display the worked answers for the corresponding practice problems on an overhead projector.*

**Evaluate Understanding**

**PRI 3**  
**PRI 10**

Teacher asks the students to discuss the following situation by conducting a think-pair-share with the whole class.

INCLUDED IN THE STUDENT MANUAL

**Task #9: Brian and Luis**

Brian stated that the following system of linear equations has two solutions. Luis stated that it has an infinite number of solutions. How would you determine the number of solutions? Who made the mistake and what is incorrect about their thinking? Who is correct and how can you tell?

$$\begin{cases} y = -2x + 5 \\ 6x + 3y = 15 \end{cases}$$



### Closing Activity

**PRI 3**

Teacher should refer students to Task #10: Exit Slip:

INCLUDED IN THE STUDENT MANUAL

#### Task #10: Exit Slip

1. How can you recognize when a system of equations has no solution?

---

---

2. Provide a solution for the following system and a non-solution. Explain your reasoning.

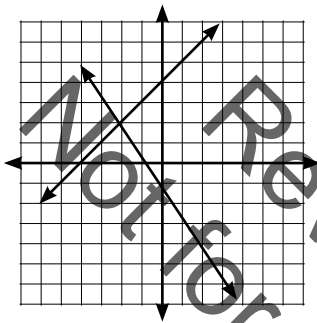

---

---

---

---

3. Sketch and label the three outcomes when graphing a system of linear equations.

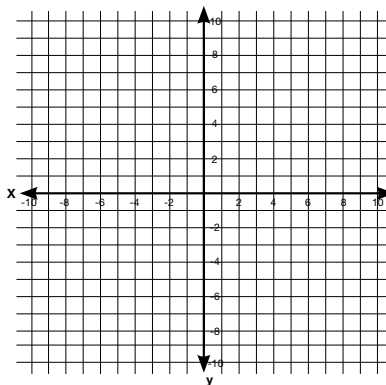
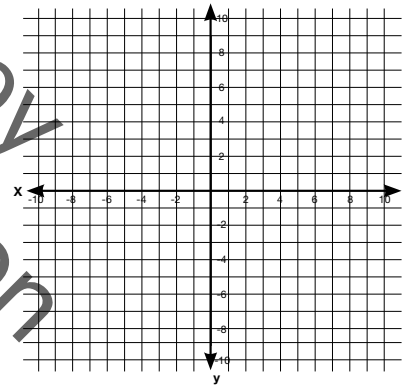
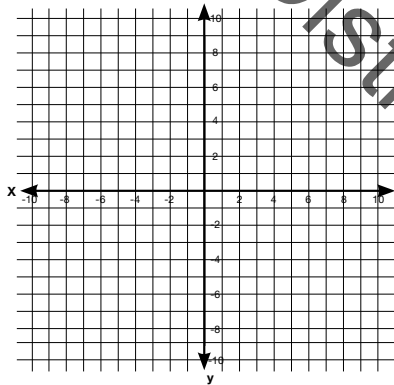

### Independent Practice:

---

Additional practice can be found at: <https://www.ixl.com/math/grade-8>  
(Once on the website, locate the following lessons: Y.1, Y.2, Y.4 for student practice.)

### Resources/Instructional Materials Needed:

---

White boards and dry erase markers (class set)  
Photocopies of coordinate planes  
Overhead projector/document camera  
Task #7: Test Questions  
Task #8: Systems of Equations Practice  
Task #9: Brian & Luis  
Task #10: Exit Slip

Review Copy  
Not for Distribution

## Systems of Equations

# Lesson 5 of 9

## Systems of Linear Equations

### College- and Career-Readiness Standards Addressed:

---

Understand the connections between proportional relationships, lines and linear equations.

- EE.12 Graph proportional relationships, interpreting the unit rate as the slope of the graph. Compare two different proportional relationships represented in different ways. *For example, compare a distance-time graph to a distance-time equation to determine which of two moving objects has greater speed.*

Analyze and solve linear equations and pairs of simultaneous linear equations.

- EE.15 Analyze and solve pairs of simultaneous linear equations.
  - a. Understand that solutions to a system of two linear equations in two variables correspond to points of intersection of their graphs, because points of intersection satisfy both equations simultaneously.
  - b. Solve systems of two linear equations in two variables algebraically, and estimate solutions by graphing the equations. Solve simple cases by inspection. For example,  $3x + 2y = 5$  and  $3x + 2y = 6$  have no solution because  $3x + 2y$  cannot simultaneously be 5 and 6.
  - c. Solve real-world and mathematical problems leading to two linear equations in two variables. For example, given coordinates for two pairs of points, determine whether the line through the first pair of points intersects the line through the second pair.
- F.4 Construct a function to model a linear relationship between two quantities. Determine the rate of change and initial value of the function from a description of a relationship or from two  $(x, y)$  values, including reading these from a table or from a graph. Interpret the rate of change and initial value of a linear function in terms of the situation it models, and in terms of its graph or a table of values.

### Mathematical Process Readiness Indicator(s) Emphasized:

---

- PRI 1: Make sense of problems and persevere in solving through reasoning and exploration.
- PRI 2: Reason abstractly and quantitatively by using multiple forms of representations to make sense of and understand mathematics. PRI 3: Describe and justify mathematical understandings by constructing viable arguments, critiquing the reasoning of others and engaging in meaningful mathematical discourse.
- PRI 4: Contextualize mathematical ideas by connecting them to real-world situations. Model with mathematics.
- PRI 6: Attend to precision.
- PRI 7: Look for and make use of patterns and structure.
- PRI 9: Demonstrate flexible use of strategies and methods while reflecting on which procedures seem to work best for specific types of problems.

Sequence of  
Instruction

Activities Checklist

## Engage

### PRI 1

Teacher asks: Have you ever had to plan a party or make decisions given a budget or set amount of spending money? Describe your decision making process.

For a pizza party situation, you can discuss ideas like determining how much food or drink items to purchase. Generate a list of items required for a party and discuss which items are variable (e.g., amount of food and drink needed) and which items are constant regardless of the number of people in attendance.

## Explore

### PRI 2

Teacher presents the following situation and models the thought processes used to solve:

Ms. England is planning a party for students who have met their goal of reading seven books during the most recent nine weeks of school. Using a total of \$112, she plans to get pizzas that cost \$12 each and drinks that cost \$0.50 each. If she purchases four times as many drinks as pizzas, how many of each should she buy? (*8 Pizzas and 32 Drinks*)

Teacher asks the following guiding questions.

What are the unknown pieces of information in this scenario? (*These are our variables.- Let  $p$  represent the number of pizzas and  $d$  represent the number of drinks.*)

The first clue is about the total amount of money spent.

On what did Ms. England spend \$112? (*pizza and drinks*)

How much did all of the pizzas cost?  *$12p$*

How much did all of the drinks cost?  *$0.5d$*

Write the equation representing the scenario. ( *$12p + 0.5d = 112$* )

The second clue is about the amount of items purchased.

Did Ms. England purchase more drinks or more pizza? (*Drinks*)

Therefore,  $d = 4p$ . For example, if she purchased 1 pizza then she bought 4 drinks because that would mean she purchased four times as many drinks as pizzas.

Let's graph the two equations:

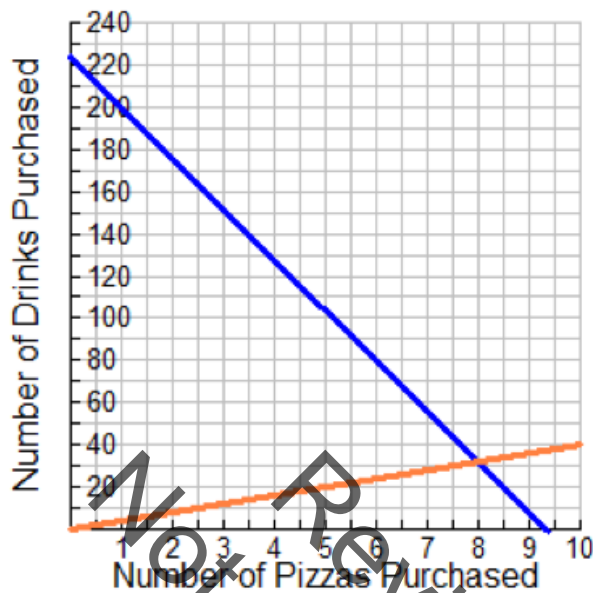

### Evaluate Understanding

**PRI 9**  
**PRI 3**

Teacher organizes students into groups of 2-3 and distributes one of the four scenarios below to each pair.

The student groups are asked to make a poster to visually represent and explain the answers to each question asked in their scenario.

Once the group has made their poster, the teacher distributes a handout, with all four scenarios.

Each group works collaboratively with its members to answer the questions for the remaining three scenarios.

The initial posters that were created should now be hung around the room. All student groups should now complete a gallery walk. If a group notices a discrepancy or a possible area of improvement between their work and that on a reviewed poster, they should write these on a sticky note and adhere it to the poster. After the gallery walk, each group presents their poster, explaining their thought process and problem solving method(s). They have the opportunity to answer questions and correct any mistakes noted.

INCLUDED IN THE STUDENT MANUAL

### Task #11: System of Equations Scenarios

#### Scenario A

The local swim center is making a special offer. They usually charge \$7 per day to swim at the pool. This month swimmers can pay an enrollment fee of \$30 and then the daily pass will only be \$4 per day.

1. Suppose you do not take the special offer. Write an equation that represents the amount of money you would spend based on how many days you go to the pool if the passes were bought at full price.

---

2. Write a second equation that represents the amount of money you would spend if you decided to take the special offer.

---

3. After how many days of visiting the pool will the special offer be a better deal?

---

4. You only have \$60 to spend for the summer on visiting this pool. Which offer would you take? Explain.

---

---

---

---

---

---

#### Scenario B

Kimi and Jordan are each working during the summer to earn money in addition to their weekly allowance, and they are saving all their money. Kimi earns \$9 an hour at her job, and her allowance is \$8 per week. Jordan earns \$7.50 an hour, and his allowance is \$16 per week.

5. Write an equation that can be used to calculate the total of Kimi's allowance and job earnings at the end of one week given the number of hours she works.

---

6. Write an equation that can be used to calculate the total of Jordan's allowance and job earnings at the end of one week given the number of hours worked.

---

7. Jordan wonders who will save more money in a week if they both work the same number of hours.

---

8. When will both girls save the same amount of money?

---

### Scenario C

Your boss asks you to visually display three plans and compare them so you can point out the advantages of each plan to your customers.

- Plan A costs a basic fee of \$29.95 per month and 10 cents per text message
- Plan B costs a basic fee of \$90.20 per month and has unlimited text messages
- Plan C costs a basic fee of \$49.95 per month and 5 cents per text message

All plans offer unlimited calling, calls on nights and weekends are free and long distance calls are included.

A customer wants to know how to decide which plan will save her the most money. Determine which plan has the lowest cost, given the number of text messages a customer is likely to send.

### Scenario D

Ivan's furnace has quit working during the coldest part of the year, and he is eager to get it fixed. He decides to call some mechanics and furnace specialists to see what it might cost him to have the furnace fixed. Since he is unsure of the parts he needs, he decides to compare the costs based only on service fees and labor costs. Shown below are the price estimates for labor that were given to him by three different companies. Each company has given the same time estimate for fixing the furnace.

- Company A charges \$35 per hour to its customers.
- Company B charges a \$20 service fee for coming out to the house and then \$25 per hour for each additional hour.
- Company C charges a \$45 service fee for coming out to the house and then \$20 per hour for each additional hour.

For which time intervals should Ivan choose Company A, Company B, Company C? Support your decision with sound reasoning and representations. Consider including equations, tables, and graphs.

### Possible Answers:

Scenarios:

- A) The local swim center is making a special offer. They usually charge \$7 per day to swim at the pool. This month swimmers can pay an enrollment fee of \$30 and then the daily pass will only be \$4 per day.
1. Suppose you do not take the special offer. Write an equation that represents the amount of money you would spend based on how many days you go to the pool if the passes were bought at full price.  $y = 7x$
  2. Write a second equation that represents the amount of money you would spend if you decided to take the special offer.  $y = 4x + 30$
  3. After how many days of visiting the pool will the special offer be a better deal? *10*
  4. You only have \$60 to spend for the summer on visiting this pool. Which offer would you take? Explain. *Regular offer is better because you can swim 8 times. \$60 only affords to pay for 8 swim passes. With the special, since you have to pay the \$30 enrollment fee you can only afford 7 swim session.*
- B) Kimi and Jordan are each working during the summer to earn money in addition to their weekly allowance, and they are saving all their money. Kimi earns \$9 an hour at her job, and her allowance is \$8 per week. Jordan earns \$7.50 an hour, and his allowance is \$16 per week.
1. Write an equation that can be used to calculate the total of Kimi's allowance and job earnings at the end of one week given the number of hours she works.  
 $y = 9x + 8$
  2. Write an equation that can be used to calculate the total of Jordan's allowance and job earnings at the end of one week given the number of hours worked.  
 $y = 7.5x + 16$
  3. Jordan wonders who will save more money in a week if they both work the same number of hours. Write an answer for her. *If Kimi and Jordan work less than five hours and 20 mins then Jordan will have more money if they work more than 5 hours and 20 mins. Kimi will save more money.*
  4. When will both girls save the same amount of money? *When they work for 5 hours and 20 mins.*
- C) Your boss asks you to visually display three plans and compare them so you can point out the advantages of each plan to your customers.
- Plan A costs a basic fee of \$29.95 per month and 10 cents per text message
  - Plan B costs a basic fee of \$90.20 per month and has unlimited text messages
  - Plan C costs a basic fee of \$49.95 per month and 5 cents per text message
- All plans offer unlimited calling, calls on nights and weekends are free and long distance calls are included.
- A customer wants to know how to decide which plan will save her the most money. Determine which plan has the lowest cost, given the number of text messages a customer is likely to send.



Plan A  $y = 0.1x + 29.95$

Plan B  $y = 90.20$

Plan C  $y = .05x + 49.95$

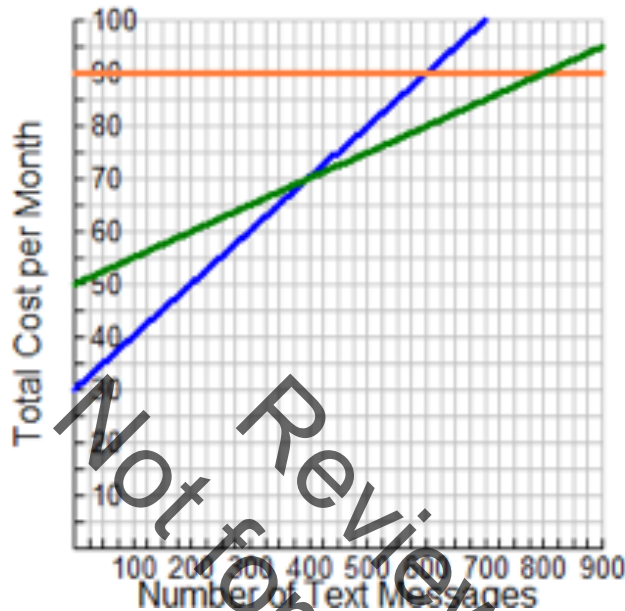

D) Ivan's furnace has quit working during the coldest part of the year, and he is eager to get it fixed. He decides to call some mechanics and furnace specialists to see what it might cost him to have the furnace fixed. Since he is unsure of the parts he needs, he decides to compare the costs based only on service fees and labor costs. Shown below are the price estimates for labor that were given to him by three different companies. Each company has given the same time estimate for fixing the furnace.

- Company A charges \$35 per hour to its customers.
- Company B charges a \$20 service fee for coming out to the house and then \$25 per hour for each additional hour.
- Company C charges a \$45 service fee for coming out to the house and then \$20 per hour for each additional hour.

For which time intervals should Ivan choose Company A, Company B, Company C? Support your decision with sound reasoning and representations. Consider including equations, tables, and graphs.

Company A:  $y = 35x$

Company B :  $y = 25x + 20$

Company C:  $y = 20x + 45$

Company A is the least expensive between 0 and 2 hours

Company A and B cost the same for a 2 hour job

Company B is the least expensive between 2 and 5 hours

Company B and C cost the same for a 5 hour job

Company C is the least expensive for a job that is more than 5 hours.

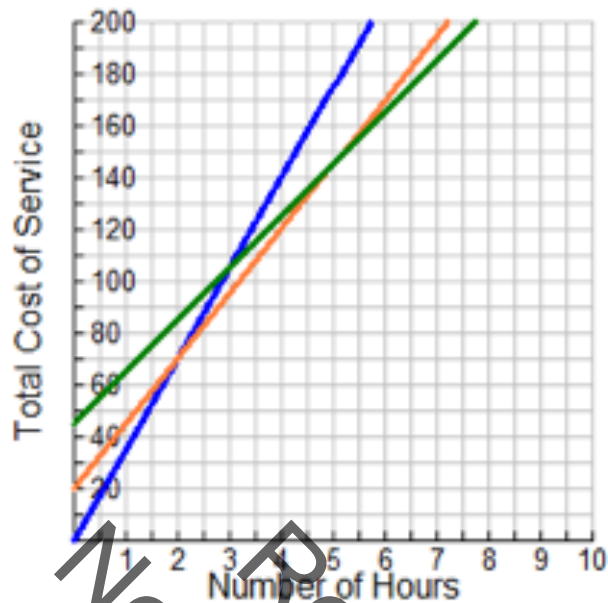

### Closing Activity

#### PRI 2

Students answer the following question on an exit ticket:

Two small pitchers and one large pitcher can hold 8 cups of water. One large pitcher minus one small pitcher constitutes 2 cups of water. How many cups of water can each pitcher hold?

Answer:

Let  $x$  = small pitcher

$y$  = large pitcher

$$2x + y = 8$$

$$y - x = 2$$

Solve by any method mentioned.

If done algebraically:

$$2x + y = 8$$

$$\underline{-x + y = 2}$$

subtract the equations:

$$3x = 6$$

$$x = 2$$

The small pitcher holds 2 cups of water.

$$2(2) + y = 8$$

$$4 + y = 8$$

$$y = 4$$

The large pitcher holds 4 cups of water.

### Independent Practice:

---

<https://www.ixl.com/math/grade-8/solve-a-system-of-equations-by-graphing-word-problems>

### Resources/Instructional Materials Needed:

---

Poster Paper  
Sticky notes  
Graph paper  
Rulers  
Markers  
glue sticks  
tape  
Task #11: System of Equations Scenarios

Not for Review Copy  
Distribution

## Systems of Equations

# Lesson 6 of 9

## Systems of Linear Equations

### College- and Career-Readiness Standards Addressed:

---

Analyze and solve linear equations and pairs of simultaneous linear equations.

- EE.15 Analyze and solve pairs of simultaneous linear equations.
  - a. Understand that solutions to a system of two linear equations in two variables correspond to points of intersection of their graphs, because points of intersection satisfy both equations simultaneously.
  - b. Solve systems of two linear equations in two variables algebraically, and estimate solutions by graphing the equations. Solve simple cases by inspection. For example,  $3x + 2y = 5$  and  $3x + 2y = 6$  have no solution because  $3x + 2y$  cannot simultaneously be 5 and 6.
  - c. Solve real-world and mathematical problems leading to two linear equations in two variables. For example, given coordinates for two pairs of points, determine whether the line through the first pair of points intersects the line through the second pair.

Use functions to model relationships between quantities.

- F.4 Construct a function to model a linear relationship between two quantities. Determine the rate of change and initial value of the function from a description of a relationship or from two  $(x, y)$  values, including reading these from a table or from a graph. Interpret the rate of change and initial value of a linear function in terms of the situation it models, and in terms of its graph or a table of values.

### Mathematical Process Readiness Indicator(s) Emphasized:

---

- PRI 1: Make sense of problems and persevere in solving through reasoning and exploration.
- PRI 2: Reason abstractly and quantitatively by using multiple forms of representations to make sense of and understand mathematics.
- PRI 3: Describe and justify mathematical understandings by constructing viable arguments, critiquing the reasoning of others and engaging in meaningful mathematical discourse.
- PRI 4: Contextualize mathematical ideas by connecting them to real-world situations. Model with mathematics.
- PRI 5: Use appropriate tools strategically to support thinking and problem solving.
- PRI 6: Attend to precision.
- PRI 8: Look for and express regularity in repeated reasoning.

- PRI 9: Demonstrate flexible use of strategies and methods while reflecting on which procedures seem to work best for specific types of problems.
- PRI 10: Reflect on mistakes and misconceptions to improve mathematical understanding.

The following *Formative Assessment Lesson* is a classroom-ready lesson included to help teachers assess and improve students' understanding of mathematical concepts and skills and their ability to use the mathematical process readiness indicators critical for college readiness.

Research has shown that formative assessment, as embodied in the following lesson, is a powerful way to improve student learning and performance. This approach first allows students to demonstrate their prior understandings and abilities in employing the mathematical processes, and then resolve their own difficulties and misconceptions through structured discussion. This results in more secure long-term learning, reducing the need for re-teaching that otherwise takes so much classroom time.

Many often ask, why don't students just remember the procedures they have been taught and practiced? The fact is, that approach works fine in the short term but, as every teacher knows, if procedural knowledge is not underpinned by conceptual understanding, students will quickly forget "how to do it."

Read more about the *Formative Assessment Lesson* rationale, structure, and philosophy using the *Brief Guide for Teachers and Administrators* that can be found at <http://map.mathshell.org/materials/index.php>.

---

## CONCEPT DEVELOPMENT

---

Mathematics Assessment Project  
**CLASSROOM CHALLENGES**  
A Formative Assessment Lesson

# Classifying Solutions to Systems of Equations

Mathematics Assessment Resource Service  
University of Nottingham & UC Berkeley

For more details, visit: <http://map.mathshell.org>  
© 2015 MARS, Shell Center, University of Nottingham  
May be reproduced, unmodified, for non-commercial purposes under the Creative Commons license  
detailed at <http://creativecommons.org/licenses/by-nc-nd/3.0/> - all other rights reserved

## Classifying Solutions to Systems of Equations

### MATHEMATICAL GOALS

This lesson unit is intended to help you assess how well students are able to:

- Classify solutions to a pair of linear equations by considering their graphical representations.
- Use substitution to complete a table of values for a linear equation.
- Identify a linear equation from a given table of values.
- Graph and solve linear equations.

### COMMON CORE STATE STANDARDS

This lesson relates to the following *Standards for Mathematical Content* in the *Common Core State Standards for Mathematics*:

8.EE: Analyze and solve linear equations and pairs of simultaneous linear equations.

This lesson also relates to **all** the *Standards for Mathematical Practice*, with a particular emphasis on:

7. Look for and make use of structure.

### INTRODUCTION

- Before the lesson, students attempt the assessment task individually. You then review students' solutions and formulate questions that will help them improve their work.
- During the lesson, students work collaboratively in pairs or threes, plotting graphs, completing tables of values and deducing equations. Then, based on the number of common solutions, students link these representations.
- In a follow-up lesson, students receive your comments on the assessment task and use these to attempt the similar task, approaching it with insights gained from the lesson.

### MATERIALS REQUIRED

- Each student will need a copy of the assessment tasks *Working with Linear Equations* and *Working with Linear Equations (revisited)*, a mini-whiteboard, eraser, and a pen.
- Each group of students will need cut up *Card Set A: Equations, Tables & Graphs*, two cut up copies of *Card Set B: Arrows*, one copy of *Graph Transparency*, copied onto a transparency, a transparency pen, a large sheet of paper for making a poster, some plain paper, and a glue stick.
- Provide rulers if requested. There are some projector resources to support whole-class discussion.

### TIME NEEDED

15 minutes before the lesson for the assessment task, a 80-minute lesson (or split into two shorter lessons), and 15 minutes in a follow-up lesson (or for homework). All timings are approximate.

<b>Common issues:</b>	<b>Suggested questions and prompts:</b>
<p><b>Student assumes that only one of the tables satisfies the equation <math>y = 2x + 3</math> (Q1)</b> For example: The student selects only table A.</p>	<ul style="list-style-type: none"> <li>• Are there more than three pairs of values that satisfy the equation <math>y = 2x + 3</math>?</li> <li>• Have you checked the values for <math>x</math> and <math>y</math> in each of the tables?</li> </ul>
<p><b>Student makes an incorrect assumption about the multiplicative properties of zero (Q1 &amp; Q2)</b> For example: The student assumes <math>2 \times 0 + 3 = 5</math>. They then may select Table B as satisfying the equation <math>y = 2x + 3</math> (Q1)</p>	<ul style="list-style-type: none"> <li>• Is <math>4 \times 0</math> the same as <math>4 \times 1</math>?</li> <li>• Use addition to figure out two multiplied by zero. [E.g. <math>0 + 0 = 0</math>.]</li> </ul>
<p><b>Student applies the rules for multiplying negative numbers incorrectly (Q1 &amp; Q2)</b> For example: The student assumes <math>2 \times -1 + 3 = 5</math> They then may select Table C as satisfying the equation <math>y = 2x + 3</math> (Q1)</p>	<ul style="list-style-type: none"> <li>• Is <math>3 \times -2</math> the same as <math>3 \times 2</math>?</li> </ul>
<p><b>Student provides little or no explanation (Q1)</b></p>	<ul style="list-style-type: none"> <li>• What method did you use when checking which tables satisfy the equation? Write what you did.</li> </ul>
<p><b>Student incorrectly draws the graph</b> For example: The student draws a non-linear graph.</p>	<ul style="list-style-type: none"> <li>• On your graph, is the slope always the same? Does this agree with the equation of the graph?</li> <li>• How can you check you have plotted the graph correctly?</li> </ul>
<p><b>Student uses guess and check to complete the tables of values (Q1b)</b></p>	<ul style="list-style-type: none"> <li>• Can you think of a quicker method?</li> <li>• Would changing the subject of the equation help you figure out some of the values?</li> </ul>
<p><b>Student states that the two equations, <math>y = 2x + 3</math> and <math>x = 1 - 2y</math> have no common solutions (Q1c)</b> For example: The student fails to extend the line <math>x = 1 - 2y</math> beyond the values in the table. This means the two lines do not intersect.</p>	<ul style="list-style-type: none"> <li>• What does 'common solution' mean?</li> <li>• Are there any other points that satisfy the equation <math>x = 1 - 2y</math>? Plot some.</li> </ul>
<p><b>Student provides little or no explanation (1c and 2)</b></p>	<ul style="list-style-type: none"> <li>• Explain why you think your answer is correct.</li> </ul>
<p><b>Student either does not plot a line that has no common solutions with the line <math>y = 2x + 3</math> or plots it incorrectly (Q2)</b></p>	<ul style="list-style-type: none"> <li>• Sketch two lines that have no common solutions. What property do they share? [The lines will be parallel.]</li> </ul>
<p><b>Student uses guess and check to figure out the equation of the line (Q2)</b></p>	<ul style="list-style-type: none"> <li>• Can you think of a quicker method?</li> <li>• What can you tell me about two lines with no common solution? Give me two equations that have no common solution.</li> </ul>



## SUGGESTED LESSON OUTLINE

### Whole-class introduction (10 minutes)

Give each student a mini-whiteboard, pen, and eraser. Maximize participation in the discussion by asking all students to show you solutions on their mini-whiteboards.

Write the equation  $y = 3x + 2$  on the board.

Ask the following questions in turn:

*If  $x = 5$  what does  $y$  equal? [17]*

Ask students to explain how they arrived at their answer. If a variety of values are given within the class, discuss any common mistakes and explore different strategies.

*If  $x = -1$  what does  $y$  equal? [-1]*

If students are struggling with multiplying by a negative number, ask the class to summarize the results of multiplying with positives and negatives. Some students may believe that because  $x$  and  $y$  are different letters, they have to take different values. Point out that here both  $x$  and  $y$  can both be equal to  $-1$ .

*If  $y = 8$  what does  $x$  equal? [2]*

*If  $y = 0$  what does  $x$  equal? [- $\frac{2}{3}$ ]*

Students may either use guess and check or rearrange the equation in order to figure out the value for  $x$ . You may want to discuss these two strategies.

Students often think that they have made a mistake when they get an answer that is not a whole number. Discuss the value of checking an answer by substituting it back in as  $x$ , as well as emphasizing that not all solutions will be positive integers and that negative and fractional solutions can also occur.

It may also be appropriate to discuss the benefits of leaving answers in fraction form rather than converting to a decimal, especially when a recurring decimal will result. Provide an example of say,  $\frac{1}{2}$ , and discuss the difference between this fraction expressed as a decimal, and  $-\frac{2}{3}$  expressed as a decimal, in terms of accuracy and rounding.

*How can you check your answer? [By substituting it back in as  $x$ .]*

*How can you check that all your answers are correct? [Sketch the coordinates on a grid and see if they form a straight line.]*

If students' work on the assessment task has highlighted issues with plotting points and making connections between solutions to a linear equation and points on a straight line graph, it may be appropriate to ask students to check that the solutions for the equation  $y = 3x + 2$  form a straight line when plotted.

Explain to students that in the next activity they will be using their skills of substitution and solving equations to help them to investigate graphical representations of linear equations.

### Collaborative activity: Card Set A: Equations, Tables & Graphs (20 minutes)

Organize students into pairs.

For each pair provide a cut up copy of *Card Set A: Equations, Tables & Graphs* and some plain paper.

*These six cards each include a linear equation, a table of values and a graph. However, some of the information is missing.*

*In your pairs, share the cards between you and spend a few minutes, individually, completing them. You may need to do some calculations to complete the cards. Do these on the plain paper and be prepared to explain your method to your partner.*

*Once you have had a go at filling in the cards on your own, take turns to explain your work to your partner. Your partner should check your cards and challenge you if they disagree. It is important that you both understand and agree on the answers for each card.*

*When completing the graphs, take care to plot points carefully and make sure that the graph fills the grid in the same way as it does on Cards C1 and C3.*

Slide P-1: *Card set A: Equations, Tables, Graphs* on the projector resource summarizes these instructions.

If students are struggling, suggest that they focus on Cards C4 and C5 first.

It does not matter if students are unable to complete all six cards. It is more important that they can confidently explain their strategies and have a thorough understanding of the skills they are using.

For students who complete all the cards successfully and need an extension, ask them to spend a few minutes comparing their completed cards:

*Select two cards and note on your whiteboards any common properties of the equations and/or the graphs. Repeat this for all of your completed cards. This will help you later.*

While students work in small groups you have two tasks: to make a note of students approaches to the task, and to support student reasoning.

#### **Note student approaches to the task**

Listen and watch students carefully and note any common mistakes. For example, are students misinterpreting the slope and intercept on cards where the graph has already been drawn? Do they fail to recognize an equation/graph that has a negative gradient? You may want to use the questions in the *Common issues* table to help address misconceptions.

Also notice the way in which students complete the cards. Do students use the completed table of values to plot the graph or do they use their knowledge of slope and intercept to draw the graph directly from the equation? Do students first plot the line using easy values for  $x$  or  $y$ , and then read off values from the graph in order to complete the table? Do students rearrange the equation or do they use guess and check to solve for  $x$  or  $y$ ? Do students use multiplication to eliminate the fraction from the equation? Do students use the slope and intercept or guess and check to figure out the equation of the graph?

You will be able to use this information in the whole-class discussion.

#### **Support student reasoning**

Try not to make suggestions that move students towards a particular strategy. Instead, ask questions to help students to reason together.

*Martha completed this card. Jordan, can you explain Martha's work?*

*Show me a different method from your partner's to check their method is correct.*

If you find the student is unable to answer this question, ask them to discuss the work further. Explain that you will return in a few minutes to ask a similar question.

*How can you check the card is correct? [Read off coordinates from the line, use the slope and intercept to check the equation matches the line, etc.]*

For each card, encourage students to explain their reasoning and methods carefully.

*How do you know that  $y=3$  when  $x=2$  in Card C2? What method did you use?*

*How did you find the missing equation on Card C1/C3? Show me a different method.*

*Suppose you multiply out the equation on Card C4. What information can you then deduce about the graph? [The  $y$ -intercept and slope.]*

*Which of these equations is arranged in a way that makes it easy to draw a graph using information about the line's  $y$ -intercept and slope? [C5.] What are they? [4 and  $-\frac{1}{2}$ .]*

You may find some students struggle when the slope of a line is negative or when dealing with negative signs, or when the slope is a fraction.

### Checking work (15 minutes)

Ask students to exchange their completed cards with another pair of students.

*Carefully check the cards and point out any answers you think are incorrect.*

*You must give a reason why you think the card is incorrect but do not make changes to the card.*

Once students have checked another group's cards, they need to review their own cards taking into account comments from their peers and make any necessary changes.

### Extending the lesson over two days

If you are taking two days to complete the unit then you may want to end the first lesson here. At the start of the second day, briefly remind students of their previous work before moving on to the next collaborative activity.

### Collaborative activity: Using Card Set B to link Card Set A (20 minutes)

Give each pair two copies of *Card Set B: Arrows* (already cut-up), a copy of *Graph Transparency*, a transparency pen, a large sheet of paper for making a poster, and a glue stick.

*Choose two of your completed cards from Card Set A and stick them on your poster paper with a gap in between.*

*You are going to try and link these cards with one of the arrows.*

*The cards will either have no common solutions, one common solution or infinitely many common solutions. Select the appropriate arrow and stick it on your poster between the two cards. If the cards have one common solution, you will need to complete the arrow with the values of  $x$  and  $y$  where this solution occurs.*

*Add another completed card to your poster and compare it with the two already stuck down. Find arrows that link this third card with the other two and stick the cards down.*

*Continue to compare all the cards in this way, making as many links as possible. If some of the cards are incomplete, you will need to complete them before comparing them.*

Slide P-2: *Card set B: Arrows* on the projector resource summarizes these instructions.

Some students might find it helpful to use a transparency when comparing the cards.

*How might you use the Graph Transparency on your desk to help you to determine how many solutions the two cards have in common?*

If students are struggling to identify how to use the transparency, ask them if tracing one of the graphs onto the transparency might be helpful. Some students may prefer to not use the transparency.

Notice how students are working and their method for completing the task. Are any students relying purely on the algebraic representation of the equation? Once students have recognized that there is one common solution, are they checking the solution algebraically as well as using the graphs?

As students work on the comparisons, support them as before. Again you may want to use some of the questions in the *Common issues*. Walk around and ask students to explain their decisions.

The finished poster produced may look like this:

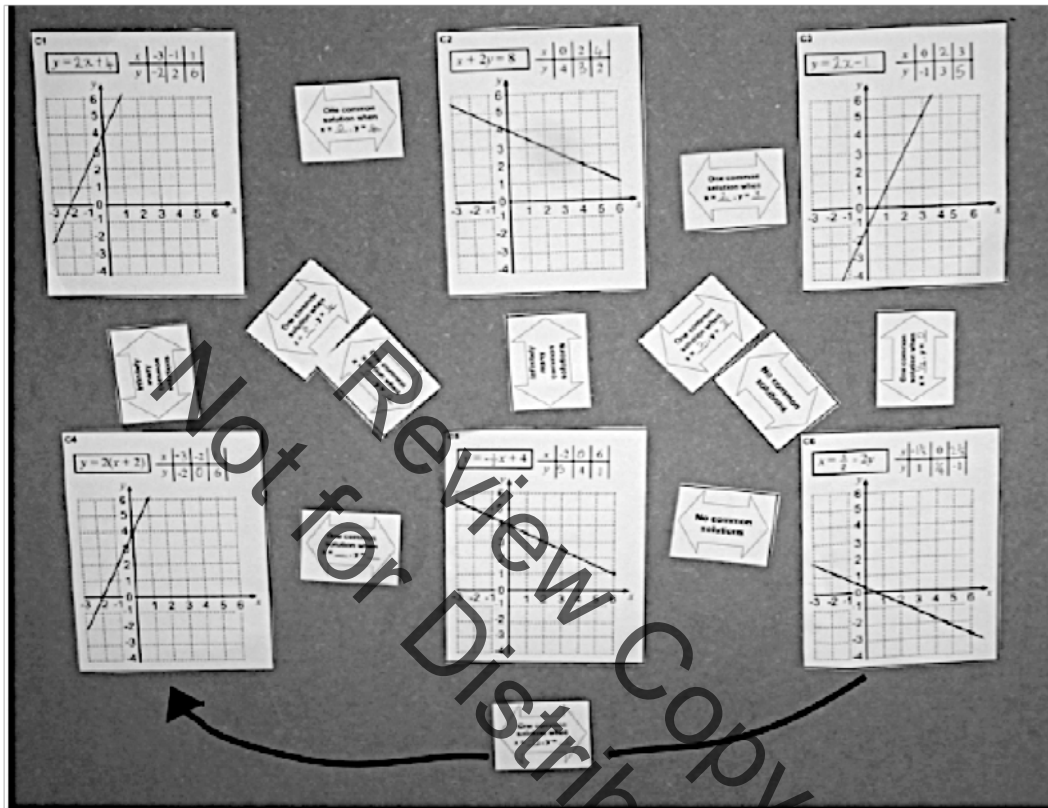

**Whole-class discussion (15 minutes)**

Once groups have completed their posters, display them at the front of the room. Based on what you have learned about your students' strategies and the review of their posters, select one or two groups to explain how they went about addressing the task (if possible select groups who have taken very different approaches to the task). As groups explain their strategies, ask if anyone has a question for the group or if anyone used a similar strategy.

When a few groups have had a chance to share their approach, consolidate what has been learned. Using mini-whiteboards to encourage all students to participate, ask the following questions in turn:

1. *Show me two equations that have one common solution.*  
*[E.g.  $y = 2x + 4$  and  $y = -\frac{1}{2}x + 4$ .]*  
*What are the solution values for  $x$  and  $y$ ? [ $x = 0$  and  $y = 4$ .]*  
*What happens to the graphs at this point? [They intersect each other.]*  
*On your mini-whiteboards make up two more equations that have one common solution. Don't use equations that appear on the cards. Sketch their graphs. Now show me!*
  
2. *Show me two equations that have no common solutions.*  
*[E.g.  $y = 2x + 4$  and  $y = 2x - 1$ .]*

*How do you know they have no common solution?  
[They are parallel lines so will never intersect.]  
What do you notice about these two equations?  
[They have the same coefficient of x/same slope.]  
On your mini-whiteboards make up two more equations that have no common solutions.  
Don't use equations that appear on the cards. Sketch their graphs. Now show me!*

3. *Show me two equations with infinitely many common solutions.  
[E.g.  $y = 2x + 4$  and  $y = 2(x + 2)$ .]  
What do you notice about the two graphs for these equations? [They are the same line.]  
Why is this? [ $2(x + 2)$  is  $2x + 4$  in factorized form.]*

The focus of this discussion is to explore the link between the graphical representations of the equations and their common solutions, even though students may have used both the algebraic representation and the table of values during the classification process. Help students to recognize that solutions to a system of two linear equations in two variables correspond to the points of intersection of their graphs, as well as what it means graphically when there are no or infinitely many common solutions.

**Follow-up lesson: Working with Linear Equations (revisited) (15 minutes)**

Give back the responses to the original assessment task to students and a copy of the task *Working with Linear Equations (revisited)*.

Ask students to look again at their solutions to the original task together with your comments. If you have not added questions to individual pieces of work then write your list of questions on the board. Students should select from this list only those questions they think are appropriate to their own work.

*Look at your solutions to the original task Working with Linear Equations and read through the questions I have written.*

*Use what you have learned to answer these questions.*

*Using what you have learned, have a go at the second sheet: Working with Linear Equations (revisited).*

Some teachers give this as a homework task.

**SOLUTIONS**

**Assessment task: Working with Linear Equations**

- 1a. Tables A and D satisfy the equation  $y = 2x + 3$ .  
Table B satisfies the equation  $y = x + 5$  and table C is non-linear.

b.

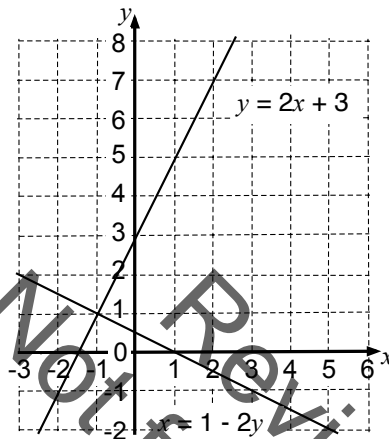

$$y = 2x + 3$$

$x$	-2	0	1
$y$	-1	3	5

$$x = 1 - 2y$$

$x$	0	1	5
$y$	0.5	0	-2

- c. The two graphs have one common solution at  $x = -1, y = 1$ . This is the point of intersection of the two graphs.
2. Students can draw any line that has the same slope as  $y = 2x + 3$ . For example  $y = 2x$  or  $y = 2x + 1$  etc.

**Lesson task: Card Sets A and B**

The six cards in *Card Set A* describe the four straight lines below:

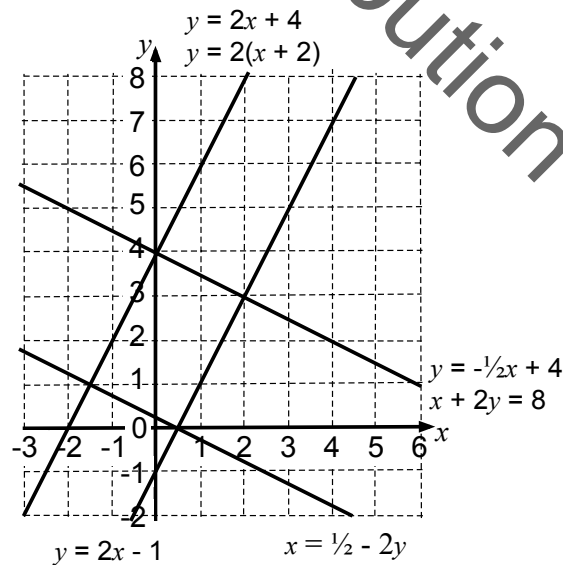

**C1**

$$y = 2x + 4$$

$x$	-3	-1	1
$y$	-2	2	6

**C4**

$$y = 2(x + 2)$$

$x$	-3	-2	1
$y$	-2	0	6

**C2**

$$x + 2y = 8$$

$x$	0	2	4
$y$	4	3	2

**C5**

$$y = -\frac{1}{2}x + 4$$

$x$	-2	0	6
$y$	5	4	1

**C3**

$$y = 2x - 1$$

$x$	0	2	3
$y$	-1	3	5

**C6**

$$x = \frac{1}{2} - 2y$$

$x$	-1.5	0	2.5
$y$	1	0.25	-1

**Infinitely many common solutions**

$$x + 2y = 8 \text{ and } y = -\frac{1}{2}x + 4$$

$x + 2y = 8$  (C2) is a rearrangement of  $y = -\frac{1}{2}x + 4$ .

$$y = 2(x + 2) \text{ and } y = 2x + 4$$

$y = 2(x + 2)$  (C4) is the factorized form of  $y = 2x + 4$ .

**No common solutions**

$$y = 2x + 4 \text{ and } y = 2x - 1$$

Equal slopes.

$$y = -\frac{1}{2}x + 4 \text{ and } x = \frac{1}{2} - 2y$$

Equal slopes.

**One common solution**

$$y = 2x + 4 \text{ (or } y = 2(x + 2)) \text{ and } y = -\frac{1}{2}x + 4 \text{ (or } x + 2y = 8)$$

have one common solution at (0,4).

$$y = 2x + 4 \text{ (or } y = 2(x + 2)) \text{ and } x = \frac{1}{2} - 2y$$

have one common solution at (-1.5,1).

$$y = 2x - 1 \text{ and } y = -\frac{1}{2}x + 4 \text{ (or } x + 2y = 8)$$

have one common solution at (2,3).

$$y = 2x - 1 \text{ and } x = \frac{1}{2} - 2y$$

have one common solution at (0.5,0).

**Assessment task: Working with Linear Equations (revisited)**

1a. Tables B and D satisfy the equation  $y = 2x + 2$ .

Table A is non-linear and table C satisfies the equation  $y = 3x + 1$ .

b.

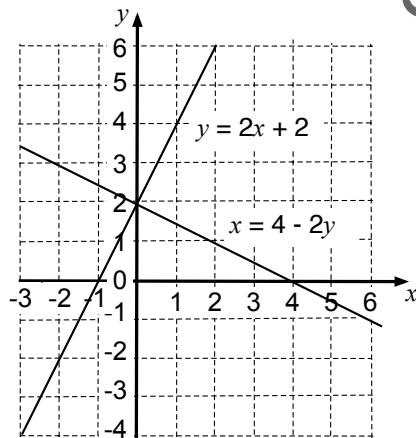

$$y = 2x + 2$$

$x$	-3	0	2
$y$	-4	2	6

$$x = 4 - 2y$$

$x$	2	4	6
$y$	1	0	-1

c. The two graphs have one common solution at  $x = 0, y = 2$ . This is the point of intersection of the two graphs.

2. Students can draw any line that has the same slope as  $y = 2x + 2$ . For example  $y = 2x$  or  $y = 2x + 1$  etc.

## Working with Linear Equations

$x$	-3	2	3
$y$	-3	7	9

A

$x$	0	2	4
$y$	5	7	9

B

$x$	-1	0	2
$y$	5	1	7

C

$x$	-1	0	2
$y$	1	3	7

D

1a. Which of these tables of values satisfy the equation  $y = 2x + 3$ ? Explain how you checked.

.....

.....

.....

b. By completing the table of values, draw the lines  $y = 2x + 3$  and  $x = 1 - 2y$  on the grid.

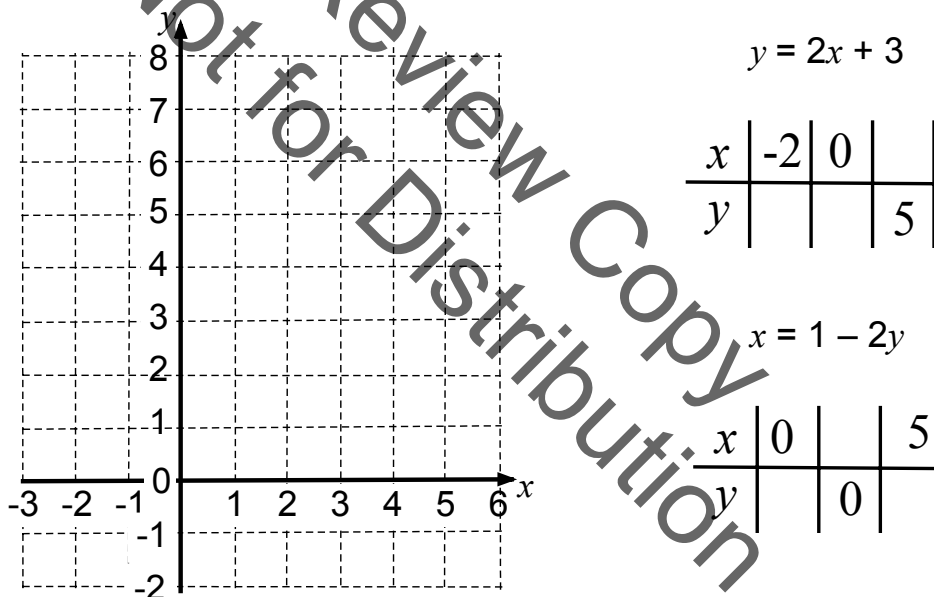

c. Do the equations  $y = 2x + 3$  and  $x = 1 - 2y$  have one common solution, no common solutions, or infinitely many common solutions? Explain how you know.

.....

.....

2. Draw a straight line on the grid that has no common solutions with the line  $y = 2x + 3$ . What is the equation of your new line? Explain your answer.

.....



### Card Set A: Equations, Tables & Graphs

C1

$y = \text{---}$

$x$	$y$
-3	1
2	2

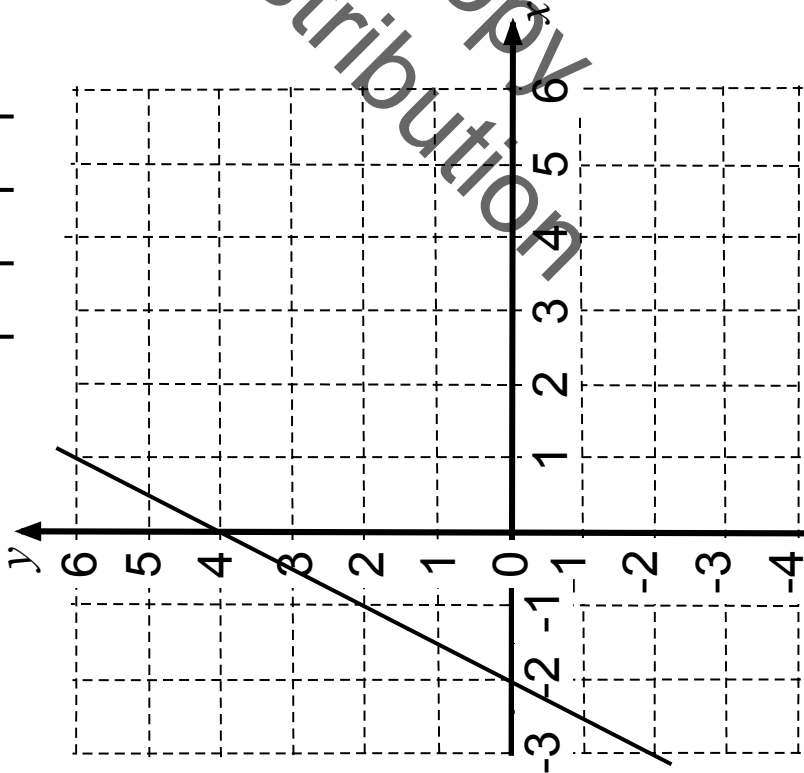

C2

$x + 2y = 8$

$x$	$y$
0	2
4	2

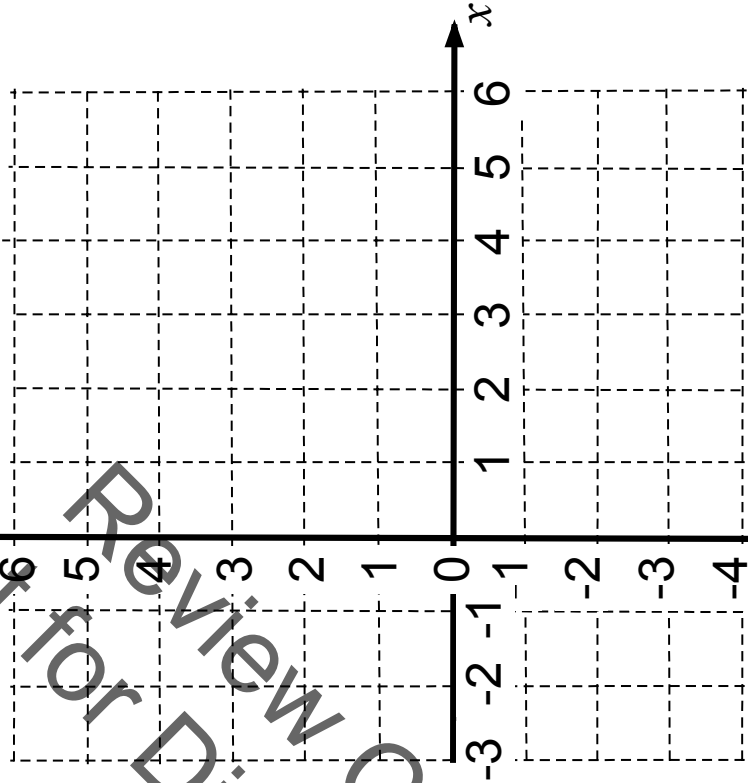

### Card Set A: Equations, Tables & Graphs (continued)

C3

$y = \text{---}$

$x$	0	3
$y$	-1	3

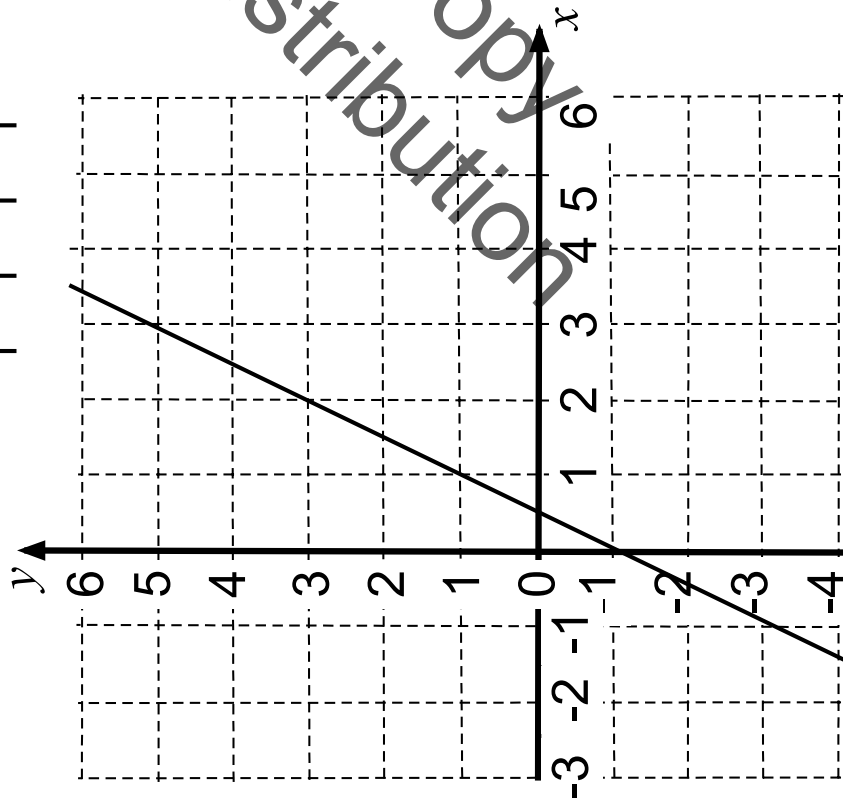

C4

$y = 2(x + 2)$

$x$	-2
$y$	-2
	6

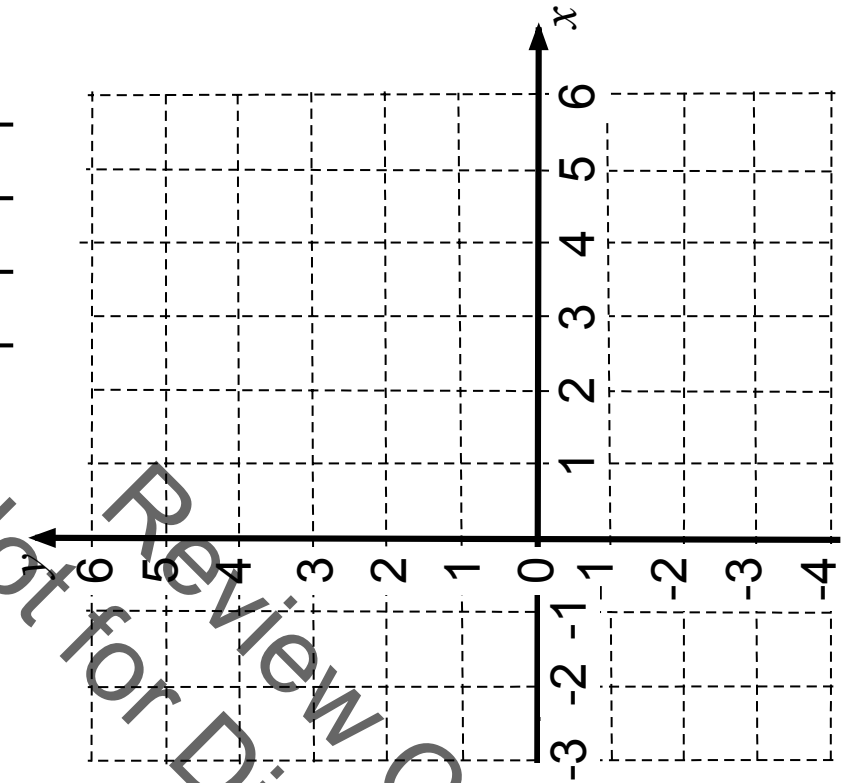

### Card Set A: Equations, Tables & Graphs (continued 2)

C5

$$y = -\frac{1}{2}x + 4$$

$x$	-2		6
$y$		4	

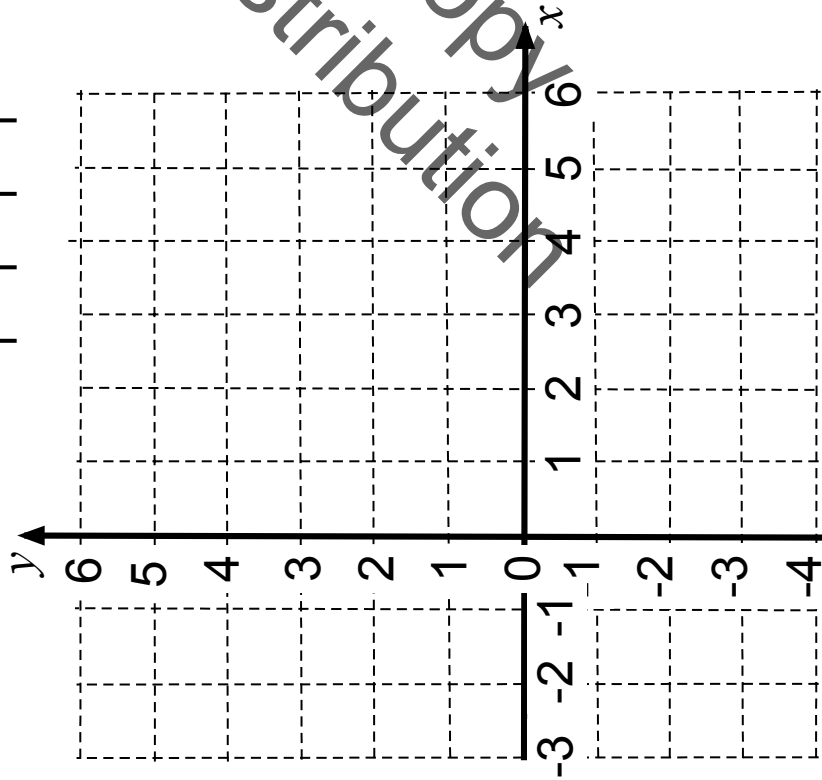

C6

$$x = \frac{1}{2} - 2y$$

$x$		0
$y$	1	-1

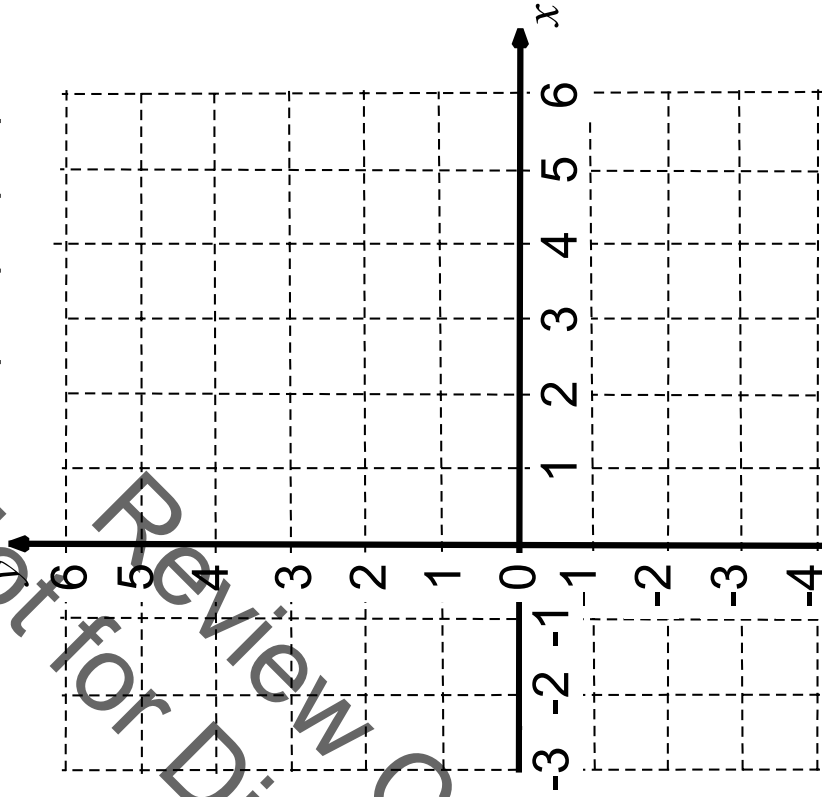

### Card Set B: Arrows

No common solutions	No common solutions	No common solutions	Infinitely many common solutions
One common solution when $x = \underline{\quad}, y = \underline{\quad}$	One common solution when $x = \underline{\quad}, y = \underline{\quad}$	One common solution when $x = \underline{\quad}, y = \underline{\quad}$	One common solution when $x = \underline{\quad}, y = \underline{\quad}$
One common solution when $x = \underline{\quad}, y = \underline{\quad}$	One common solution when $x = \underline{\quad}, y = \underline{\quad}$	One common solution when $x = \underline{\quad}, y = \underline{\quad}$	One common solution when $x = \underline{\quad}, y = \underline{\quad}$

# Graph Transparency

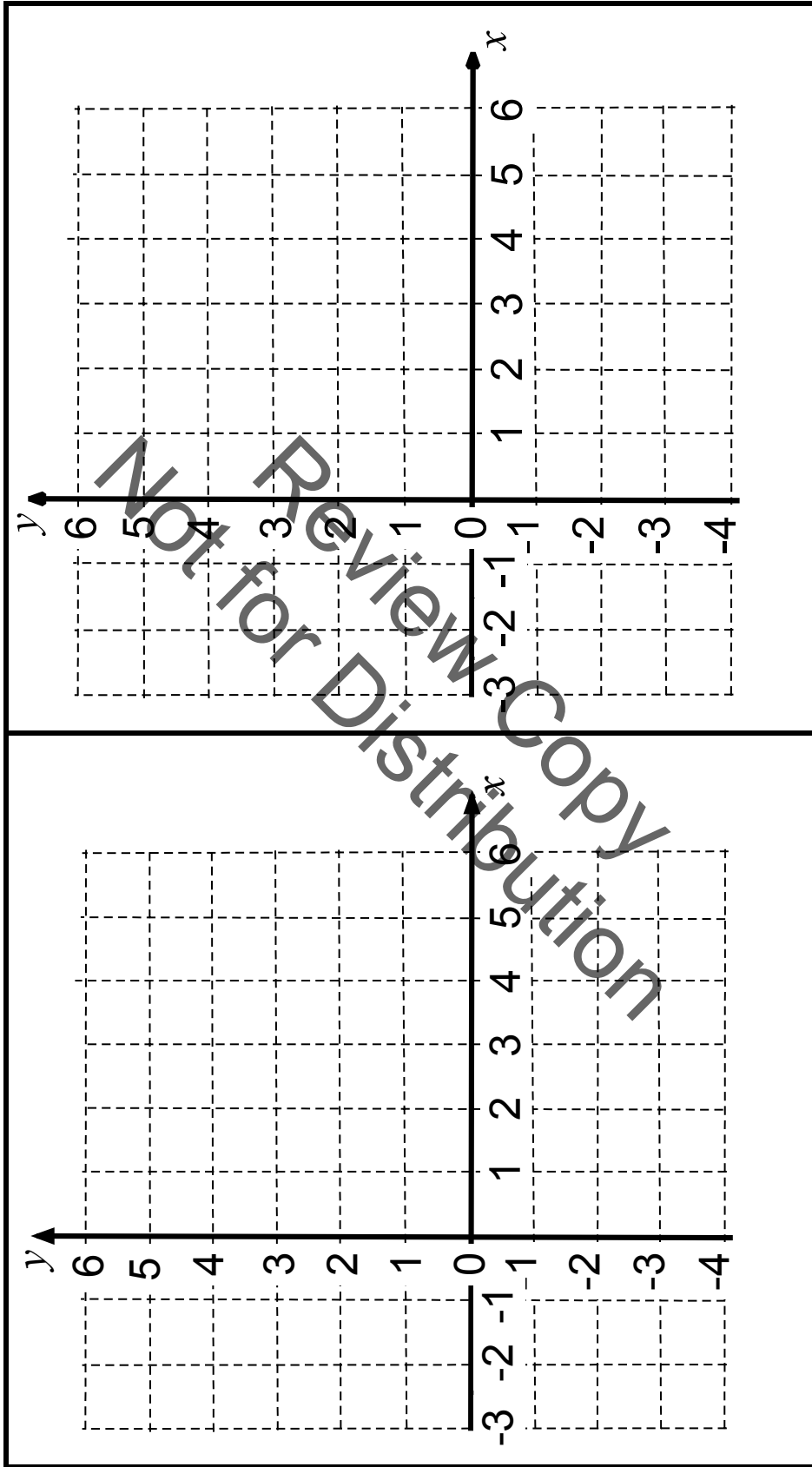

## Working with Linear Equations (revisited)

$x$	0	1	2
$y$	4	4	5

A

$x$	1	2	3
$y$	4	6	8

B

$x$	-2	-1	1
$y$	-5	-2	4

C

$x$	-2	-1	1
$y$	-2	0	4

D

1a. Which of these tables of values satisfy the equation  $y = 2x + 2$ ? Explain how you checked.

.....

.....

.....

b. By completing the table of values, draw the lines  $y = 2x + 2$  and  $x = 4 - 2y$  on the grid.

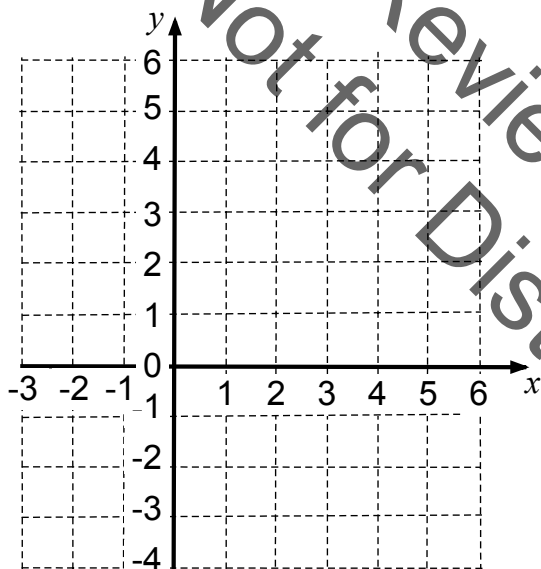

$$y = 2x + 2$$

$x$	-3	0	
$y$			6

$$x = 4 - 2y$$

$x$		4	6
$y$	1		

c. Do the equations  $y = 2x + 2$  and  $x = 4 - 2y$  have one common solution, no common solutions, or infinitely many common solutions? Explain how you know.

.....

.....

2. Draw a straight line on the grid that has no common solutions with the line  $y = 2x + 2$ . What is the equation of your new line? Explain your answer.

.....

.....

## Card Set A: Equations, Tables, Graphs

1. Share the cards between you and spend a few minutes, individually, completing the cards so that each has an equation, a completed table of values and a graph.
2. Record on paper any calculations you do when completing the cards. Remember that you will need to explain your method to your partner.
3. Once you have had a go at filling in the cards on your own:
  - Explain your work to your partner.
  - Ask your partner to check each card.
  - Make sure you both understand and agree on the answers.
4. When completing the graphs:
  - Take care to plot points carefully.
  - Make sure that the graph fills the grid in the same way as it does on Cards C1 and C3.

**Make sure you both understand and agree on the answers for every card.**

## Card Set B: Arrows

1. You are going to link your completed cards from *Card Set A* with an arrow card.
2. Choose two of your completed cards and decide whether they have no common solutions, one common solution or infinitely many common solutions. Select the appropriate arrow and stick it on your poster between the two cards.
3. If the cards have one common solution, complete the arrow with the values of  $x$  and  $y$  where this solution occurs.
4. Now compare a third card and choose arrows that link it to the first two. Continue to add more cards in this way, making as many links between the cards as possible.



## Mathematics Assessment Project **Classroom Challenges**

These materials were designed and developed by the  
Shell Center Team at the Center for Research in Mathematical Education  
University of Nottingham, England:

**Malcolm Swan,**  
**Nichola Clarke, Clare Dawson, Sheila Evans, Colin Foster, and Marie Joubert**  
with  
**Hugh Burkhardt, Rita Crust, Andy Noyes, and Daniel Pead**

We are grateful to the many teachers and students, in the UK and the US,  
who took part in the classroom trials that played a critical role in developing these materials

The classroom observation teams in the US were led by  
**David Foster, Mary Bouck, and Diane Schaefer**

This project was conceived and directed for  
The Mathematics Assessment Resource Service (MARS) by  
**Alan Schoenfeld** at the University of California, Berkeley, and  
**Hugh Burkhardt, Daniel Pead, and Malcolm Swan** at the University of Nottingham

Thanks also to Mat Crosier, Anne Floyde, Michael Galan, Judith Mills, Nick Orchard, and Alvaro Villanueva who contributed to the design and production of these materials

This development would not have been possible without the support of  
**Bill & Melinda Gates Foundation**

We are particularly grateful to  
**Carina Wong, Melissa Chabran, and Jamie McKee**

The full collection of Mathematics Assessment Project materials is available from

<http://map.mathshell.org>

© 2015 MARS, Shell Center, University of Nottingham  
This material may be reproduced and distributed, without modification, for non-commercial purposes,  
under the Creative Commons License detailed at <http://creativecommons.org/licenses/by-nc-nd/3.0/>  
All other rights reserved.

Please contact [map.info@mathshell.org](mailto:map.info@mathshell.org) if this license does not meet your needs.

## Systems of Equations

# Lesson 7 of 9

## Systems of Linear Equations

### College- and Career-Readiness Standards Addressed:

---

- EE.15 Analyze and solve pairs of simultaneous linear equations.
  - a. Understand that solutions to a system of two linear equations in two variables correspond to points of intersection of their graphs, because points of intersection satisfy both equations simultaneously.
  - b. Solve systems of two linear equations in two variables algebraically, and estimate solutions by graphing the equations. Solve simple cases by inspection. For example,  $3x + 2y = 5$  and  $3x + 2y = 6$  have no solution because  $3x + 2y$  cannot simultaneously be 5 and 6.

### Mathematical Process Readiness Indicator(s) Emphasized:

---

- PRI 1: Make sense of problems and persevere in solving through reasoning and exploration.
- PRI 2: Reason abstractly and quantitatively by using multiple forms of representations to make sense of and understand mathematics.
- PRI 3: Describe and justify mathematical understandings by constructing viable arguments, critiquing the reasoning of others and engaging in meaningful mathematical discourse.
- PRI 6: Attend to precision.

Sequence of Instruction

Activities Checklist

Engage

PRI 2

Pose the following questions to students:

Consider the graph of the system of equations

$$\begin{cases} y = 3x + 5 \\ y = 8x + 3 \end{cases}$$

Can you estimate the solution to this system of equations?

Students should recognize that is difficult to identify a precise solution, but their answers should include an x-coordinate between 0 and 1, and a y-coordinate just greater than 6.

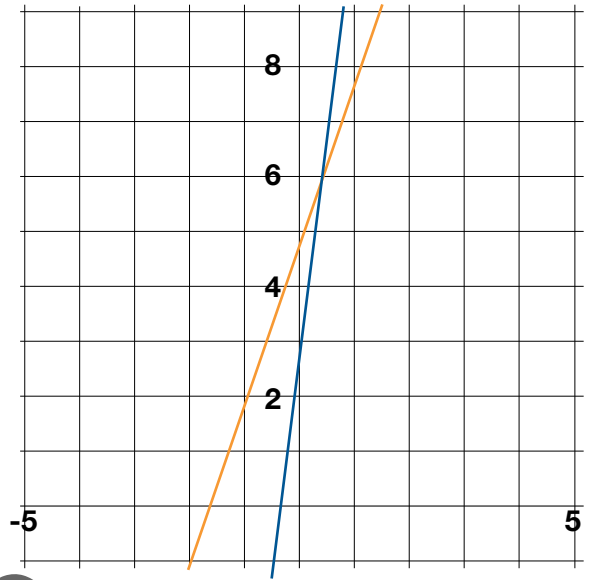

Explore

PRI 1

PRI 6

Explain to students that when a precise answer is needed, it may be necessary to use another method to solve a system of equations. The first alternative method you will explore is the substitution method.

Since both equations are equal to  $y$ , they should be equal to each other. Explain to students that by setting the expressions  $3x + 5$  and  $8x + 3$  equal will allow them to solve for the precise x-coordinate of their solution:

$$3x + 5 = 8x + 3$$

$$2 = 5x$$

$$\frac{2}{5} = x$$

To determine the y-coordinate, replace the x-coordinate in one of the equations with the determined value:

$$y = 3\left(\frac{2}{5}\right) + 5$$

$$y = \frac{6}{5} + 5$$

$$y = \frac{6}{5} + \frac{25}{5} = \frac{31}{5}$$

Have students verify that the answer is the same if the other equation was used.

Say to students: Using our more precise method, we determined the solution to the system is the ordered pair  $\left(\frac{2}{5}, \frac{31}{5}\right)$ . Is this close to our estimated solution? Does this look like it could be the solution on the graph?

## Explanation

Complete the following problem as a whole group:

Does the following system have a solution:  $\begin{cases} y = 7x - 2 \\ 2y - 4x = 10 \end{cases}$  ? How do you know?

Since this system has a solution, we will solve it without graphing. While the two expressions are not equal to the same value, we do know what  $y$  is. Since we know that  $y = 7x - 2$ , we can replace  $y$  with  $7x - 2$  in the second equation:

$$2y - 4x = 10$$

$$2(7x - 2) - 4x = 10$$

Now, we have one equation which will allow us to solve for the  $x$ -coordinate:

$$14x - 4 - 4x = 10$$

$$10x - 4 = 10$$

$$10x = 14$$

$$x = \frac{14}{10} = \frac{7}{5}$$

Now that we know the  $x$ -coordinate, just like our previous example, we can replace  $x$  with value in one of the equations to determine the  $y$ -coordinate:

$$y = 7\left(\frac{7}{5}\right) - 2$$

$$y = \frac{49}{5} - 2$$

$$y = \frac{49}{5} - \frac{10}{5} = \frac{39}{5}$$

Therefore, the solution to the system is  $\left(\frac{7}{5}, \frac{39}{5}\right)$ .

## Practice Together / in Small Groups / Individually

### PRI 3

Have students complete the following problems individually or in pairs:

INCLUDED IN THE STUDENT MANUAL

#### Task #12: Solving a System Using Substitution

Solve the following systems of equations without graphing:

a.  $\begin{cases} x = 6y + 7 \\ x = 10y + 2 \end{cases}$       b.  $\begin{cases} 2x - 5 = y \\ -3x - 1 = 2y \end{cases}$       c.  $\begin{cases} x = -9 + y \\ x = 4y - 6 \end{cases}$

Explain how you used substitution to determine your answers.

Answers:

$$\text{a. } \begin{cases} x = 6y + 7 \\ x = 10y + 2 \end{cases} ; \left( \frac{29}{2}, \frac{5}{4} \right)$$

$$\text{b. } \begin{cases} 2x - 5 = y \\ -3x - 1 = 2y \end{cases} ; \left( \frac{9}{7}, \frac{17}{7} \right)$$

$$\text{c. } \begin{cases} x = -9 + y \\ x = 4y - 6 \end{cases} ; (-10, -1)$$

Have students share their work with the class and explain how they determined their solutions to the previous problems. Pay careful attention to how they used substitution

### Evaluate Understanding

After student groups share their solutions to the previous problems, have them revisit the hot air balloon problem from Lesson 4:

INCLUDED IN THE STUDENT MANUAL

#### Task #13: Return to Hot Air Balloon Problem

In lesson 4, we modeled the paths of two hot air balloons using the equations  $y = 70 - 6x$  and  $y = 10 + 15x$ , where  $x$  represented time in seconds, and  $y$  represented height in meters. Use substitution to determine the exact time that the hot air balloons are the same height above the ground.

Prompt students: Recall in Lesson 3, we used the two equations and to discover that the two hot air balloons would be the same height above the ground between 2 and 3 seconds. Use substitution to determine the exact time the balloons would be the same height above the ground.

Solution:

$$70 - 6x = 10 + 15x$$

$$60 = 21x$$

$$2.86 \text{ seconds} \approx x$$

### Closing Activity

As a whole group, have students discuss and list the main points of the lesson.

### Independent Practice:

Solve the following systems of equations using substitution. Support your answer by graphing the system.

INCLUDED IN THE STUDENT MANUAL

#### Task #14: Independent Practice

Solve the following systems of equations using substitution. Support your answers by graphing.

1. 
$$\begin{cases} 4x - 5y = 19 \\ y = 7x - 10 \end{cases}$$

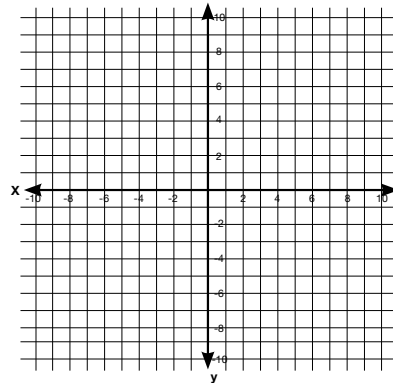

2. 
$$\begin{cases} 2y = 3x - 6 \\ 2y = 11x - 1 \end{cases}$$

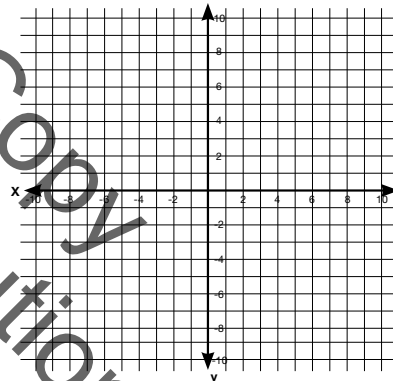

3. 
$$\begin{cases} y = \frac{4}{5}x - 9 \\ -4x + 5y = 7 \end{cases}$$

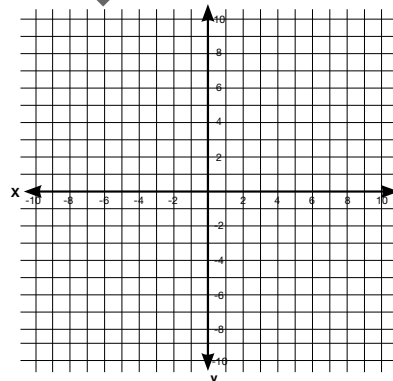

Review Copy  
Not for Distribution

$$1. \begin{cases} 4x - 5y = 19 \\ y = 7x - 10 \end{cases}; (1, -3)$$

$$2. \begin{cases} 2y = 3x - 6 \\ 2y = 11x - 1 \end{cases}; \left(-\frac{5}{8}, -\frac{63}{16}\right)$$

$$3. \begin{cases} y = \frac{4}{5}x - 9 \\ -4x + 5y = 7 \end{cases}; \text{(No solution)}$$

### Resources/Instructional Materials Needed:

---

Graph paper

Graphing calculator (optional)

Task #12: Solving a System Using Substitution

Task #13: Return to Hot Air Balloon

Task #14: Independent Practice

Not for Review Copy  
Not for Distribution

## Systems of Equations

# Lesson 8 of 9

## Systems of Linear Equations

### College- and Career-Readiness Standards Addressed:

- EE.15 Analyze and solve pairs of simultaneous linear equations.
  - a. Understand that solutions to a system of two linear equations in two variables correspond to points of intersection of their graphs, because points of intersection satisfy both equations simultaneously.
  - b. Solve systems of two linear equations in two variables algebraically, and estimate solutions by graphing the equations. Solve simple cases by inspection. For example,  $3x + 2y = 5$  and  $3x + 2y = 6$  have no solution because  $3x + 2y$  cannot simultaneously be 5 and 6.

### Mathematical Process Readiness Indicator(s) Emphasized:

- PRI 1: Make sense of problems and persevere in solving through reasoning and exploration.
- PRI 3: Describe and justify mathematical understandings by constructing viable arguments, critiquing the reasoning of others and engaging in meaningful mathematical discourse.
- PRI 4: Contextualize mathematical ideas by connecting them to real-world situations. Model with mathematics.
- PRI 6: Attend to precision.

Sequence of  
Instruction

Activities Checklist

### Engage

In the previous lesson, we learned that systems of equations could be solved without using a graph or table of values. Notice that the first step was to “eliminate” one of the variables.

For instance, for the system  $\begin{cases} y = 3x + 5 \\ y = 8x + 3 \end{cases}$ , we set the expressions equal to each other,

which allowed us to “eliminate” the variable  $y$  and solve for  $x$ . In our other class

example  $\begin{cases} y = 7x - 2 \\ 2y - 4x = 10 \end{cases}$ , we replaced  $y$  in the second equation with the expression

$7x - 2$ , which again allowed us to “eliminate”  $y$  and solve for  $x$ .

In this lesson, we will learn another method for solving a system of equations that will allow us to eliminate one of the variables in a different way.



## Explore

**PRI 1**  
**PRI 6**

Consider the following problem as a whole group:

The sum of two numbers is 112 and the difference of the same two numbers is 26. Set up and solve a system of equations to determine each number.

Talk students through setting up the problem:

If  $x$  = the larger number, and  $y$  = the smaller number, then the system of equations should be:

$$\begin{cases} x + y = 112 \\ x - y = 26 \end{cases}$$

Can you think of a way to eliminate one of the variables without using substitution?

Allow students time to explore the problem and share their ideas with the class. If necessary, talk them through with the following prompts:

Notice that the expressions  $y$  and  $-y$  are opposites. If the equations are added together, this will eliminate the variable  $y$ , which will allow us to solve for  $x$ :

$$\begin{aligned} 2x &= 138 \\ x &= 69 \end{aligned}$$

Now that we know the value of  $x$ , we can replace  $x$  in one of the equations to determine the value of  $y$ :

$$\begin{aligned} 69 + y &= 112 \\ y &= 43 \end{aligned}$$

Therefore, the two numbers are 69 and 43.

## Explanation

**PRI 1**  
**PRI 4**  
**PRI 6**

As a whole group, work the following problem:

**INCLUDED IN THE STUDENT MANUAL**

### Task #15: Smarties and Lifesavers

Suppose Ms. Lopez bought bags of Smarties and Lifesavers as a special treat for her math students. Each bag of Smarties cost \$6.40 (including tax), and each bag of Lifesavers cost \$4.25 (including tax). She spent a total of \$57.50 on eleven bags of candy. Using this information, set up and solve a system of equations without graphing.

What do we need to do first?

What equations should we use in our system of equations?

Solve the system of equations using the elimination method.

Possible Answers:

Suppose Ms. Lopez bought bags of Smarties and Lifesavers as a special treat for her math students. Each bag of Smarties cost \$6.40 (including tax), and each bag of Lifesavers cost \$4.25 (including tax). She spent a total of \$57.50 on eleven bags of candy. Using this information, set up and solve a system of equations without graphing.

What do we need to do first? (*Sample student response: First, we need to define our variables.  $x$  = number of bags of Smarties and  $y$  = number of bags of Lifesavers.*)

What equations should we use in the system? (*Sample student response:  $x + y = 11$  and  $6.40x + 4.25y = 57.50$* )

If we solve the system of equations using elimination, which variable should we eliminate?

It most likely is not obvious to students at this point which variable to eliminate. If students are having trouble, prompt them with the following questions:

How could we determine how many bags of Smarties Ms. Lopez bought? In our previous problem, when two of the terms were opposites, we were able to add the equations and eliminate one of the variables. Is that possible with these two equations? If not, is there a way that we can manipulate one or both equations to form opposites for one of the variables?

Students should notice that initially, there are no opposites in the equations. If the focus is on determining the number of bags of Smarties, then guide students to the conclusion that if they multiply the first equation by  $-4.25$ , opposites are created without changing the system of equations.

If we want to know the number of bags of Smarties she bought, that means we need to eliminate the  $y$ , which represents the number of bags of Lifesavers she bought. Multiplying the entire first equation by  $-4.25$  will help us:

$$\begin{aligned} -4.25(x + y &= 11) \\ -4.25x - 4.25y &= -46.75 \end{aligned}$$

Now our new system of equations is

$$\begin{aligned} -4.25x - 4.25y &= -46.75 \\ 6.40x + 4.25y &= 57.50 \end{aligned}$$

Notice that  $-4.25y$  and  $4.25y$  are opposites, and we can add the equations together, eliminate  $y$  and solve for  $x$ :

$$\begin{aligned} 2.15x &= 10.75 \\ x &= 5 \end{aligned}$$

So, Ms. Lopez bought 5 bags of Smarties.

How can we determine the number of bags of Lifesavers Ms. Lopez bought? (*Sample student answer: substitute the 5 in place of  $x$  in one of the equations and solve for  $y$ .*)

If we replace the  $x$  with 5 in one of the equations, we are able to solve for  $y$ :

$$\begin{aligned} 5 + y &= 11 \\ y &= 6 \end{aligned}$$

So Ms. Lopez bought 5 bags of Smarties and 6 bags of Lifesavers for her math students.

### Practice Together / in Small Groups / Individually

**PRI 3**  
**PRI 6**

In pairs or small group of 3, have students work the following problems.

INCLUDED IN THE STUDENT MANUAL

#### Task #16: Solving Systems of Equations Using Elimination

Solve the following systems of equations using the elimination method.

1. 
$$\begin{cases} 2x + 3y = 20 \\ -2x + y = 4 \end{cases}$$

2. 
$$\begin{cases} 3x + 4y = 10 \\ 2x + 3y = 7 \end{cases}$$

3. 
$$\begin{cases} 2x - y = 1 \\ 6x - 3y = 3 \end{cases}$$

Answers:

1. 
$$\begin{cases} 2x + 3y = 20 \\ -2x + y = 4 \end{cases} ; (1, 6)$$

2. 
$$\begin{cases} 3x + 4y = 10 \\ 2x + 3y = 7 \end{cases} ; (1, 2)$$

2. 
$$\begin{cases} 2x - y = 1 \\ 6x - 3y = 3 \end{cases} ; \text{infinite solutions}$$

As students are working, be sure to circulate and listen for their reasoning. Have student pairs share their methods with the class.

## Evaluate Understanding

**PRI 1**  
**PRI 4**  
**PRI 6**

(Adapted from the task “How Much Did They Cost” in the Georgia Frameworks, | Grade 8, Unit 7)

*This assignment may be used as an exit ticket or homework.*

INCLUDED IN THE STUDENT MANUAL

### Task #17: How Much Did They Cost?

Mr. Nelson went to Taco Town to get lunch for the eighth-grade teachers. He bought eight tacos and five burritos, and the total cost before tax was \$13.27. The next time he went back to Taco Town, he got six tacos and seven burritos for a cost of \$14.47 before tax. The teachers now want to pay Mr. Nelson, but Mr. Nelson doesn't remember how much one taco costs or how much one burrito costs.

Find the cost of one taco and the cost of one burrito, using the elimination method. Provide a written explanation and a graph that supports your work to present to the teachers so that they will understand how you solved the problem.

*The cost of each taco is \$0.79 cents and the cost of each burrito is \$1.39.*

## Closing Activity

As a whole group, have students discuss and list the main points of the lesson.

## Independent Practice:

<http://map.mathshell.org/tasks.php?collection=9&unit=MA12>

INCLUDED IN THE STUDENT MANUAL

### Task #18: Fencing

Jon buys fencing for his yard.

He pays \$122 for 5 fence posts and 4 fence panels.

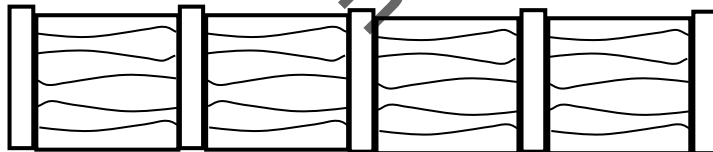

He pays \$570 for 21 fence posts and 20 fence panels.

How much does he pay for 4 fence posts and 3 fence panels? \_\_\_\_\_

Show how you figured it out.

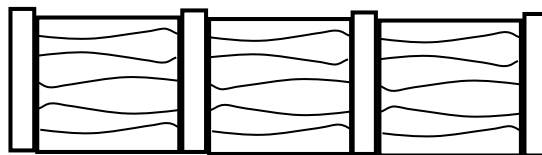

### Resources/Instructional Materials Needed:

---

Graphing calculator, optional

Task #15: Smarties and Lifesavers

Task #16: Solving Systems of Equations Using Elimination

Task #17: How Much Did They Cost?

Task #18: Fencing

Review Copy  
Not for Distribution

## Systems of Equations

# Lesson 9 of 9

## Systems of Linear Equations

### College- and Career-Readiness Standards Addressed:

---

- EE.15 Analyze and solve pairs of simultaneous linear equations.
  - a. Understand that solutions to a system of two linear equations in two variables correspond to points of intersection of their graphs, because points of intersection satisfy both equations simultaneously.
  - b. Solve systems of two linear equations in two variables algebraically, and estimate solutions by graphing the equations. Solve simple cases by inspection. For example,  $3x + 2y = 5$  and  $3x + 2y = 6$  have no solution because  $3x + 2y$  cannot simultaneously be 5 and 6.
  - c. Solve real-world and mathematical problems leading to two linear equations in two variables. For example, given coordinates for two pairs of points, determine whether the line through the first pair of points intersects the line through the second pair.

### Mathematical Process Readiness Indicator(s) Emphasized:

---

- PRI 1: Make sense of problems and persevere in solving through reasoning and exploration.
- PRI 2: Reason abstractly and quantitatively by using multiple forms of representations to make sense of and understand mathematics.
- PRI 3: Describe and justify mathematical understandings by constructing viable arguments, critiquing the reasoning of others, and engaging in meaningful mathematical discourse.
- PRI 4: Contextualize mathematical ideas by connecting them to real-world situations. Model with mathematics.
- PRI 5: Use appropriate tools strategically to support thinking and problem solving.
- PRI 6: Attend to precision.
- PRI 9: Demonstrate flexible use of strategies and methods while reflecting on which procedures seem to work best for specific types of problems.
- PRI 10: Reflect on mistakes and misconceptions to improve mathematical understanding.

Sequence of Instruction

Activities Checklist

Engage

Ask the students if they are familiar with the game show “Minute to Win It.” It is a family-friendly competition in which contestants try to complete 10 seemingly easy games for \$1 million. The contestants have 60 seconds to complete each challenge, which increase in difficulty as the game progresses, or they are eliminated.

**Act one:**

Explain to them that the task for the day is about stacking two different types of cups and determining how many cups you need for the stacks to be equal in height.

Show the first video from Andrew Stadel found at <http://www.101qs.com/1897-stacking-cups--act-1#>

Show the video 2-3 times and ask the students to make careful observations and record any questions that come to mind. Ask students “How many cups do you think you need for the stacks to be equal in height?” and have students record their best guesses on the form.

INCLUDED IN THE STUDENT MANUAL

**Task #19: Stacking Cups**

**ACT 1**

What did/do you notice?

---

---

What questions come to your mind?

---

---

---

**Main Question:** How many cups does it take for the stacks to be equal in height? Estimate the result of the main question. Explain your estimate.

---

---

---

---

---

Have students share the questions they immediately thought of and record them on the board or chart paper for everyone to see.

## Explore

### Act Two:

After students have had time to think and record their guesses, ask them: What information would be useful to know here?

INCLUDED IN THE STUDENT MANUAL

#### Task #19: Stacking Cups

##### ACT 2

What information would you like to know or do you need to solve the MAIN question?

---

---

---

---

---

---

---

---

Record the given information (measurements, materials, etc...)

---

---

---

---

---

---

---

---

Use this area for your work, tables, calculations, sketches, and final solution.

Hopefully, students would want to know some statistics (i.e., height of one cup, height of the lip of the cup, etc.). Students can measure these with a ruler, or you can provide them with visual shown on <http://www.101qs.com/1897-stacking-cups--act-1#>.





*Teacher note: The photographs include the height of each cup as well as the lip measurement.*

## Explanation

Arrange students in homogenous pairs.

Each pair should receive a ruler, yard stick, and 2 of each type of cup.

Explain to students that they should provide proof of their answers using tables, graphs and by solving algebraically.

Be sure to provide any additional information requested by students.

### Practice Together / in Small Groups / Individually

Students should use the information discovered or provided and work together to determine how many cups are needed for the stacks to be the same height.

Be sure to listen carefully and support student reasoning.

### Evaluate Understanding

After students have had ample time to work, ask several student pairs to share their answers and explain their methods for determining their solutions. Be sure to listen for differences in how they wrote their equations or constructed their graphs. Have the class test their solutions physically by stacking the cups.

#### Act Three:

After physically stacking the cups, reveal the answer by showing the Act 3 video found at <http://www.101qs.com/1897-stacking-cups--act-1#>

Students should discuss any errors and compare their answers to the correct one provided.

INCLUDED IN THE STUDENT MANUAL

#### Task #19: Stacking Cups

##### ACT 3

What was the result? Is this different from your original guess?

---

---

---

---

---

---

---

---

---

---

### Closing Activity

#### The Sequel (Whole group discussion):

Once the answer is revealed, ask students the following questions:

1. What is the height of the cups when the stacks are equal?
2. Suppose there are 50 blue plastic cups and 1 white Styrofoam cup. At what height will the white cups reach the blue cups if you continue to add one cup to each stack?

INCLUDED IN THE STUDENT MANUAL

### Task #19: Stacking Cups

#### The Sequel

1. What is the height of the cups when the stacks are equal?  
\_\_\_\_\_
2. Suppose there are 50 blue plastic cups and 1 white Styrofoam cup. At what height will the white cups reach the blue cups if you continue to add one cup to each stack?  
\_\_\_\_\_

#### Resources/Instructional Materials Needed:

Lesson videos and commentary can be found at  
<http://www.101qs.com/1897-stacking-cups--act-1#>

Rulers

Yard sticks

Styrofoam cups

Blue (or other color) Solo cups

Task #19: Stacking Cups

#### Notes:

It is suggested to download the videos/images and use in a Prezi or Power Point presentation to prevent connection issues.